

# **Solar Energy-Based Smart Street Light Control System**

**BY**

**Md. Mehedi Hasan**

**Id: 181-33-4503**

**AND**

**Badhan Roy**

**Id: 181-33-4523**

This Report Presented in Partial Fulfillment of the Requirements for the Degree of Bachelor  
of Science in Electrical and Electronic Engineering

Supervised By

**Professor Dr. Md. Shahid Ullah**

Professor & Head

Department of EEE

Daffodil International University

Co-Supervised By

**Mr. Md. Ramjan Ali**

Lecturer

Department of EEE

Daffodil International University

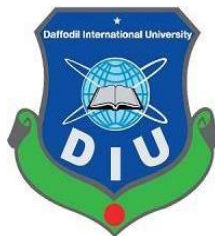

**DAFFODIL INTERNATIONAL UNIVERSITY  
DHAKA, BANGLADESH  
December 2022**

## DECLARATION

It is our sincerest declaration that this project has been done under the supervision of **Professor Dr. Md. Shahid Ullah, Professor & Head, Department of Electrical and Electronic Engineering** Daffodil International University. As well, this project and its parts have not been submitted elsewhere for the degree awards.

### Supervised by:



---

**Professor Dr. Md. Shahid Ullah**  
Professor & Head  
Department of EEE  
Daffodil International University

### Co-Supervised by:

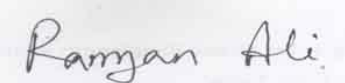

---

**Mr. Md. Ramjan Ali**  
Lecturer  
Department of EEE  
Daffodil International University

### Submitted by:



---

**Md. Mehedi Hasan**

ID: 181-33-4503

Department of EEE  
Daffodil International University



---

**Badhan Roy**

Id: 181-33-4523

Department of EEE  
Daffodil International University

Dedicated  
To  
My Parents and Honorable Teachers

# TABLE OF CONTENTS

<b>LIST OF FIGURES</b>	vi
<b>LIST OF TABLES</b>	vii
<b>LIST OF ABBREVIATIONS</b>	viii
<b>LIST OF SYMBOLS</b>	ix
<b>ACKNOWLEDGEMENT</b>	x
<b>ABSTRACT</b>	xi
<b>CHAPTER 1: INTRODUCTION</b>	
1.1 Introduction	01
1.2 Motivation	02
1.3 Problem Statements	03
1.4 Objectives	03
1.5 Significance	03
1.6 Organization	04
<b>CHAPTER 2: LITERATURE REVIEW</b>	
2.1 Introduction	05
2.2 Related Works	05
2.3 Compare and Contrast	12
2.8 Summary	14
<b>CHAPTER 3: MATERIALS AND METHODS</b>	
3.1 Introduction	15
3.2 System Design and Components	15
3.3 Design Analysis	28
3.4 Summery	29

## **CHAPTER 4: RESULTS AND DISCUSSIONS**

4.1 Results	30
4.2 Outcome Analysis and Discussions	31

## **CHAPTER 5: PROJECT MANAGEMENT**

5.1 Resources and Cost Management	34
5.2 Lesson Learned	35

## **CHAPTER 6: IMPACT ASSESSMENT OF THE PROJECT**

6.1 Economical, Societal, and Global Impact	38
6.2 Environmental and Ethical Issues	39
6.3 Utilization of Existing Standards	39
6.4 Health Concerns	40
6.5 Technical Challenges	40

## **CHAPTER 7: CONCLUSIONS AND RECOMMENDATIONS**

7.1 Conclusion	41
7.2 Future Recommendations	41
REFERENCES	42

## LIST OF FIGURES

<b>FIGURES</b>	<b>PAGE NO</b>
Figure 1.1: Solar LED street light in Dhaka	02
Figure 2.4: Solar street lights overview	08
Figure 2.5: PV cell	09
Figure 2.5.1: Types of solar panel	11
Figure 2.5.2: I-V curve of solar panel	12
Figure 2.6: Structural design of the solar street lighting system	13
Figure 3.2: Block diagram	15
Figure 3.3: Circuit diagram	16
Figure 3.4.1: Arduino Pro Mini	17
Figure 3.4.2: Comparison of dissimilar battery technologies	19
Figure 3.4.3: LDR	20
Figure 3.4.4: LED	22
Figure 3.4.5: LCD	22
Figure 3.4.6: IR Sensor	25
Figure 3.4.6.1: IR sensor operational principle	26
Figure 3.4.6.3: IR Sensor Circuit Illustration	27
Figure 3.5: Flow chart	28
Figure 4.1: The picture of the full project	30
Figure 4.2.1: Display	31
Figure 4.2.2: Object sensing at 3 no sensor	31
Figure 4.2.3: Object sensing at 2 no sensor	32
Figure 4.2.4: Object sensing at 1 no sensor	32

## LIST OF TABLES

<b>TABLES</b>	<b>PAGE NO</b>
Table 3.4.1: ARDUINO Pro Mini Pinout Configuration	17
Table 3.4.5: Pin symbol description	23
Table 5.1: Cost analysis	35

## LIST OF ABBREVIATIONS

BAETE	Board of Accreditation for Engineering and Technical Education
DIU	Daffodil International University
DC	Direct Current
AC	Alternative Current
SE	Solar Energy
EJ	Exajoules
EV	Electron-volt
SPI	Serial Peripheral Interface
TFPV	Thin Film Photovoltaic
CdTe	Cadmium telluride
a-Si	Amorphous silicon
CIGS	Copper indium gallium selenide
OPC	Organic photovoltaic cells
PWM	Pulse Width Modulation
UART	Universal Asynchronous Receiver Transmitter
TWI	Two Wire Interface
DOD	Depth Of Discharge
Ni-Cd	Nickel-Cadmium
LED	Light Emitting Diode



## LIST OF SYMBOLS

<i>Symbol</i>	<i>Name of the symbol</i>
$\omega$	Angular velocity, rad/sec
$\xi$	Damping ratio

## ACKNOWLEDGEMENT

To begin with, we would like to express our deepest gratitude to Almighty God for helping us complete this final year project.

We are thankful and desire our profound gratitude to Professor Dr. Md. Shahid Ullah, Professor & Head, Department of EEE Daffodil International University, Dhaka. Deep Knowledge & intense interest of our supervisor in the field of “**Solar energy Based Smart Street Light Control System**” to accomplish this project. The project was completed thanks to his unending patience, scholarly guidance, continual encouragement, constant and energetic supervision, constructive criticism, valuable advice, and reading many inferior drafts at all stages and correcting them.

It is with sincere thanks that we extend our sincere gratitude to Professor Dr. Md. Shahid Ullah, Department Of EEE, Daffodil International University. To thank him for their assistance in completing our project.

As part of our course work, we took part in this conversation with our classmates at Daffodil International University.

Last but not least, we must acknowledge our parents' patience and constant support with due respect.

## ABSTRACT

Distribution stations provide alternating current for most streetlights. As a result, utility companies are required to distribute more power. Currently, however, there is a possibility of using renewable energy sources for streetlights to reduce utility company consumption rates. A streetlight will turn on at 40% of its maximum intensity when there is no object beneath it, according to the program. An Arduino is set to increase the brightness to 100% if any person or vehicle passes a nearby streetlight. Upon expiration of the preset time and if there is no object detected, the intensity gradually decreases to 40%. In the morning, LDR will send a command to Arduino and the streetlight will be turned off. Battery-operated streetlights normally operate with electricity stored in them. When the battery is not sufficiently charged, streetlights will automatically switch to utility power.

*Keywords: Solar energy, streetlights, LDR, PV cells, brightness*

# CHAPTER 1

## INTRODUCTION

### 1.1 Introduction

The energy crisis is intensifying throughout the world, and countries around the world are seeking solutions to this problem. Taking advantage of renewable energy is one way to search for new sources of energy. In addition to reducing energy consumption and improving energy efficiency, we can utilize energy-saving technologies. Our planet's most direct, common, and clean energy source has been solar energy. It is estimated that the Earth absorbs a total of about 3,850,000 oxyjoules (EJ) of solar energy every year, which equals as much as all the non-renewable resources found and used by humans, including coal, oil, natural gas, and uranium. Solar resources are seemingly endless [1].

To save energy, mechanization organisms are being desired over handbook methods. Ceiling fans, washing machines, and other applications rely on these automation systems to make our lives more comfortable and convenient. Street lights are one of many exciting applications in our environment and provide the light that is essential for travel safety at night. Electrical equipment such as electric bulbs, etc., are shortened in lifespan if street lights are left on all night. Especially in cities, streetlights are a significant energy drain. Accordingly, an intelligent lighting control system can save as much as 70% on the street lighting and Make Street lighting last longer [2-3].

This device converts electrical energy into light with the help of a solid-state semiconductor. With a small size and low power consumption, the device is durable and environmentally friendly. Almost all of the LED spectrum falls into the visible range. It is therefore a solid light source with a great luminous proficiency, which can be defined as a substantial transformation. During the day, the solar panels charge the battery, while the LED light equipment provides power at night. Both new energies can be utilized and energy savings can be achieved [4].

The majority of streetlights are controlled manually today, and so they fail to switch at the proper time due to a manual error. This can keep the lights on during the day. As a result, time-based streetlights are also being used to turn on and off at preset times, but this technique still has disadvantages because of seasonal alterations in sunset and sunrise times. As well as turning on in weighty rain and overcast conditions, light sensors can overcome the above problems of switching. Moreover, motion sensors allow controlling the intensity of lighting, thereby preserving energy and reducing costs [5-6].



Figure 1.1: Solar LED Street light in Dhaka

## 1.2 Motivation

Technological advancements and the need for high levels of energy demand mean that innovation can no longer suffice deprived of sustainability. Because Dhaka is one of the most tightly populated capitals in the world, its resources are under increasing strain. There have been many innovations in the country based on renewable energy thanks to public awareness of such topics. Several sustainable technologies are starting to proliferate in the city, including biogas cookers, solar water heaters, and solar-powered rickshaws.

It is expected that locals will be able to afford these 'green' technologies due to the drive for sustainability. This drive is based on the combination of technology and sustainability. Taking advantage of the sun's free energy is a smart move. In Bangladesh, natural gas (which delivers 89% of total power generation) is

diminishing and becoming unreliable, but harnessing solar energy efficiently can continue to meet the future's electrical needs economically and sustainably.

### **1.3 Problem Statements**

In the traditional practice of solar-powered LED street lights, energy efficiency and cost-effectiveness are not considered. All of these factors will increase costs, especially PV and batteries. In addition, the weight and size of the LED system on the structure affect the structure that holds the LED lamps. A solar power system can be optimized by utilizing sensing devices, reducing the size of the installation, and minimizing power losses between generation and load. Smaller systems are more cost-effective, and the mounting structure is less complicated.

A solar streetlight that uses both conventional (electrical), as well as non-conventional (solar) energy resources, will be designed for this project. Our street lights are controlled via LDR, where the lights are turned on when the LDR value exceeds a certain threshold value. When the value falls below the threshold value the lights are switched OFF. A movement-based intensity controller is used to save and conserve energy efficiently. The obstacle is identified using a pair of sensors (IR transmitter and IR receiver). A LED associated with the receiver will turn ON if the value acquired at the receiver exceeds an earlier threshold value.

### **1.4 Objectives**

The objectives of this project are:

- To get power from solar.
- Road lights will light automatically only at night.
- The street lights will give full light when a car is near that light.

### **1.5 Significance**

Solar streetlights require no transmission lines or cables, nor do they require any special management or control. Various public places, for instance, the square, a parking lot, a campus, a street, or a highway, can be equipped with this device.

People's daily lives are closely related to street lighting. During the rapid progression of worldwide urbanization, green, proficient, also enduring LED lights steadily become part of our lives.

High efficiency, energy-saving, long life, high color rendering index, and environmental protection define a good LED street lighting system, which has a significant impact on city lighting energy savings but is also closely related to the health of the people and the economy. Therefore, an LED street light system should be designed reasonably.

## 1.6 Organization

The project book is organized as follows:

- In **chapter 1**, we cover the introduction, objective & motivation of the project.
- **Chapter 2** represents the literature review, and description of circuit elements, such as the power supply, Arduino Nano, ESP8266 module, led display, and other parts.
- **Chapter 3** describes the block diagram, circuit diagram, programming IDE, and working principle of the project. The result, discussion and outcome analysis have been discussed in **chapter 4**.
- Project management, resources and cost management also with lesson learned are discussed in **chapter 5**.
- Impact assessment of the project, economical, societal and global impact, Environmental and ethical issues, Existing standards, health concerns, technical challenges discussed in **chapter 6**.
- Conclusion and future recommendations and reference are discussed in **chapter 7**.

# CHAPTER 2

## LITERATURE REVIEW

### 2.1 Introduction

In Bangladesh and around the world, street lights are used to illuminate every city and every village. Electricity is used to power these street lights, resulting in high electricity consumption. Several improvements can be made to street lights. Solar street lighting can be made instead of electricity, which is more costly for governments. Each year, 100 million tons of carbon dioxide is emitted from the world's 300 million street lights. An estimated 40 percent of energy is wasted, costing 20 billion dollars per year. To reduce carbon footprints and operate street lights economically, high-efficiency LED luminaire with smart illumination control is in demand [7].

Power from the power grid is traditionally used to power streetlights. In cities as well as in local communities, outages and intermittent power supplies have often caused numerous deaths and property damage as a result of persistent darkness. Technology advances suggest that renewable energy sources could be used to power streetlights [8].

### 2.2 Related Works

A low-cost microcontroller-based Arduino is used in this paper [9] to propose an effective smart street lighting system. This project aims to design energy-efficient intelligent streetlights to conserve energy in existing streetlights in rural areas, urban areas, and smart cities. Among the components are a USB charger, an LED luminaire, an LED driver, a PV panel, a light sensor, a motion sensor, and an Arduino. Using traffic on the road and the time of day, the automatic streetlight adjusts itself.

The 21st century's ideal green energy will come from solar energy because it is inexhaustible and clean. Photovoltaic power generation is an efficient way to convert solar energy into electricity. Light-Emitting Diodes are components that can convert electrical current into light. Smart current control is implemented in the proposed system for



photovoltaic street lights. This is to extend the durability of the batteries and to adapt the LED discharge current to the charging state of the batteries and the lighting conditions [10].

Featuring a smart solar street lighting system that will be powered by LEDs, the goals of this study were to design and develop a greener community [11]. Solar-powered Street lighting systems differ from conventional lighting systems not only because they rely on solar energy, but they are also standalone devices that provide a reliable energy management system that minimizes energy wastage induced by faulty lighting controls.

The streetlight was constructed with sloped solar modules, energy-efficient lamps, and anticorrosion basic components. The switch to turn the light ON and off was automatically controlled. Solar streetlights produce electricity straight from the sunlight deprived of producing any emissions, noise, or vibrations. Thus, through this work [12], an alternative source for powering streetlights is provided. This reduces pressure on the national grid owing to the variations associated with the generation of electricity from fossil fuels. Solar power is the generation of electrical energy from rays. The sun's energies are our planet's most important basis of energy. Solar power can be converted into electricity in two ways. Using solar energy simply as heat is one way to utilize it. Steam from this heat drives the steam turbine. Thermal energy is produced in this way. Using PV (or solar) cells as described above allows the direct transformation of solar energy into electricity. PV cells consist of silicon semiconductors [13].

Solar cells (or PV cells) are semiconductor devices that convert light energy from the sun directly into electricity. This conversion is known as a photovoltaic conversion, and therefore PV cells are referred to as such. When sunlight strikes its terminals, it generates voltage and current. Sunlight falling upon a solar cell determines the way and amount of power it generates. Additionally, cell area and light intensity are also considered.

The intensity of light increases with power generation. Larger cells generate more power. When light falling on the front side of the cell is perpendicular to it, optimum power will be produced. Having received phosphorous and boron treatments, thin

silicon wafers are made from silicon semiconductor material. When the wafer layers are doped, they are aligned to form solar cells [14].

The positive and negative terminals of every solar cell are needed to collect the electric current, regardless of the technology and material used. At the top of the solar cell, there is a front contact, in the middle, a PN junction, and at the bottom, there is a back contact. Each photon in sunlight has a finite amount of energy. A solar cell must absorb these photons to generate electricity. A photon's energy and the bandgap energy of semiconductors determine its absorption. An electron-volt (eV) is the unit of energy that indicates the photon and bandgap energies of semiconductor materials [15].

The semiconductor materials in solar panels absorb the sun's photons. These photons produce electron-hole pairs at the junction. At the junction, electrons and holes are separated when the solar cell is connected to the load. On the negative terminal of the battery, electrons collect, and on the positive terminal, holes collect. There is therefore an electric potential between the terminals, and a voltage is generated between them. DC is then driven to DC loads, inverters, or battery charging circuits. If more photons are engrossed, the current generated will be greater. The solar radiation falls on the solar cell, but a large part of it is not converted to electricity.

Lighting structures that feature solar panels mounted on the lighting erection or integrated into the structure itself are called solar street lights. During the night, fluorescent or LED lamp is powered by a battery that is recharged by the solar panels [16]. There are four main parts to solar streetlights:

- **Solar Panel**

This solar panel converts solar energy into electricity that the street lights can use, which is one of the most important parts of a solar street light. Monocrystalline and polycrystalline solar panels are the most common types used in solar street lights. A monocrystalline solar panel has a higher conversion rate than a polycrystalline one. Wattage systems also vary with solar panels.

- **Lighting Fixture**

Nowadays, modern solar street lights usually rely on LEDs for their primary lighting source since the LED provides much higher luminance with lower power consumption.

- **Rechargeable Battery**

The solar panel generates electricity during the day and the batteries store it for use at night. Ultimately, a battery's life cycle and capacity will determine the lifespan of the light, as well as its backup days.

- **Pole**

It is imperative to have strong poles for all street lights, exclusively solar street lights where there may be components attached to the pole: fixtures, panels, and from time-to-time batteries.

### **Working Process**

It is very simple and easy to understand how solar street lights work. Using photovoltaic cells, solar street lights convert sunlight into electricity. Semiconductor materials enable solar energy to be transformed into electricity using this device. Solar batteries store electrical energy that is converted from light to electricity by the "photovoltaic effect." If the light level falls below 10lux, the solar cell board will open the circuit voltage of approximately 4.5V. After that, the charge and discharge controller determine the amount of voltage that will move from the battery to other parts of the street light system. The battery is also protected by charge and discharge controllers [17].

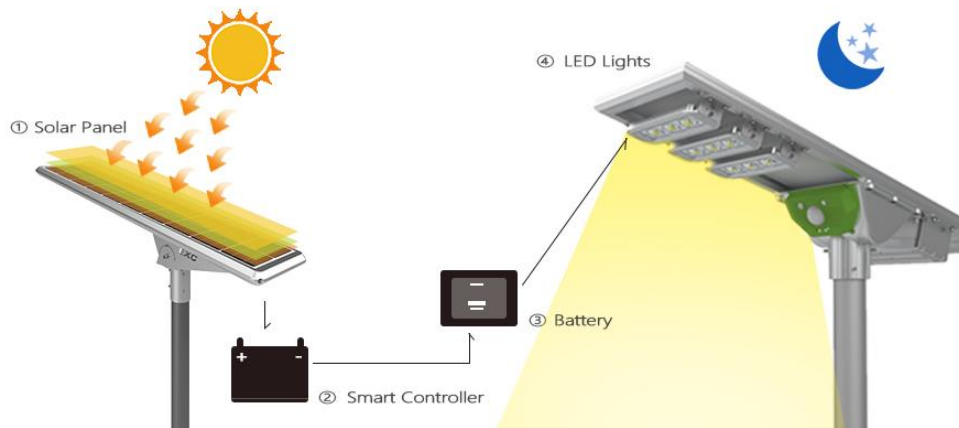

Figure 2.4: Solar Street lights overview

In photovoltaic modules, light energy (photons) is converted into electricity in the form of the photovoltaic effect. Crystalline silicon wafer-based cells or thin-film cells are used in most modules. A module can have an upper or a rear structural member (load-bearing). Membranes should be endangered alongside motorized destruction and moisture. There are also semi-flexible modules built on thin-film cells.

In series, the cells are connected to create voltage, and in equivalent, the current is increased. Module wattage is the product of the voltage and current of the module. Manufacturers of solar panels do not necessarily specify their specifications based on the actual conditions at the installation site.

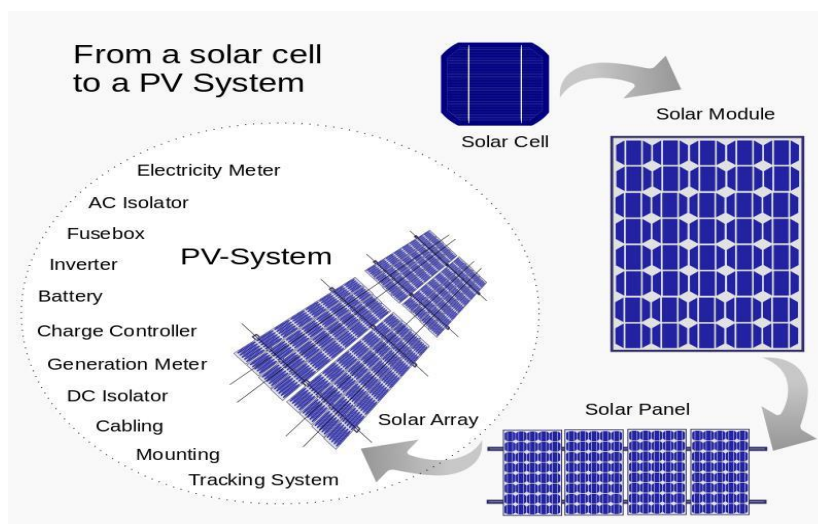

Figure 2.5: PV cell

Solar panels are equipped with a PV junction box at the back, which serves as their

output interface. Most photovoltaic modules are connected to the rest of the system with connectors made of MC4 to prevent weather damage. USB power interfaces are also available.

The solar panels or the PV system are attached in parallel or in series to provide the desired voltage or current output. Silver, copper, or other non-magnetic conductive transition metals may make up the conductors that take the current off the modules based on their ampacity. In the case of partial shading of a module, bypass diodes may be incorporated internally or externally to maximize the output of the illuminated sections. Solar PV modules with concentrators include lenses or mirrors that focus sunlight onto smaller cells. It is a cost-effective way of using cells with a high cost per unit size (such as gallium arsenide). Besides the metal frame of the solar panel, it also uses brackets, reflector shapes, and troughs for better support [18].

Almost all photovoltaic systems use silicon today. This material is available in different forms. Silicon is available in various grades of purity. There are three elementary forms of solar panels. These are,

- Monocrystalline Silicon Solar panels
- Polycrystalline Silicon Solar panels
- Thin-film Solar panels
- **Monocrystalline Solar Panels**

Occasionally referred to as single-crystalline panels, monocrystalline solar panels are best remembered as monocrystalline panels. They are extremely efficient because they are made from a single piece of silicon and use the Czochralski method to make them.

- **Polycrystalline Solar Panels**

Multi-crystalline is another alternate name for polycrystalline solar panels. Solar panels made of polysilicon are multiple pieces of silicon that are melted, treated, and flattened into rectangular shapes.

- **Thin-Film Solar Panels**

Solar panels with thin films are the least expensive and least efficient. Applied to a glass substrate, thin-film solar panels are made from a photovoltaic substance. The TFPV (Thin Film Photovoltaic) materials employed are:

- Amorphous silicon (a-Si)
- Cadmium telluride (CdTe)
- Copper indium gallium selenide (CIS/CIGS).
- Organic photovoltaic cells (OPC).

This thin film has a uniform appearance, and its flexibility means there are some novel ways in which solar energy can be harnessed. Despite its relatively recent emergence in the alternative energy industry, thin-film solar is still undergoing continuous development and change. Additionally, due to its low efficiency, it is typically only useful in commercial or industrial settings because it takes up a lot of space.

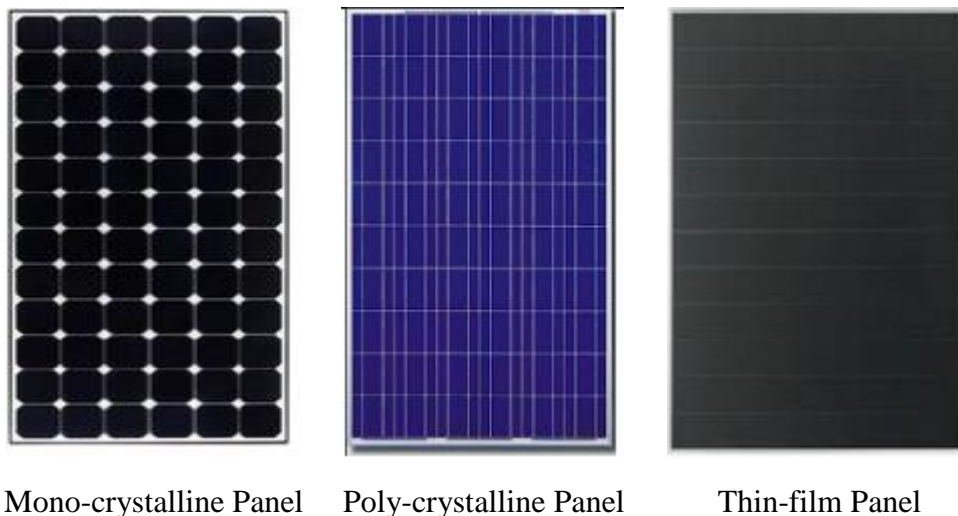

Figure 2.5.1: Types of solar panel

Figure 2.5.2 illustrates the I-V curve for a solar panel. The p-n junction of the solar

cells produces current and voltage when sunlight is shining on the panel. As shown in Figure 2.5.2, the I-V curve is affected by sunlight intensity since power is a function of current and voltage. As for the power-voltage curve, it can be calculated via the equation  $P=V*I$ . Solar panels working in sunlight will have an open-circuit voltage  $V_{oc}$  but no current if no load is connected. Solar panels with shorted terminals will have a short-circuit current  $I_{sc}$  flowing, but no voltage will be produced.

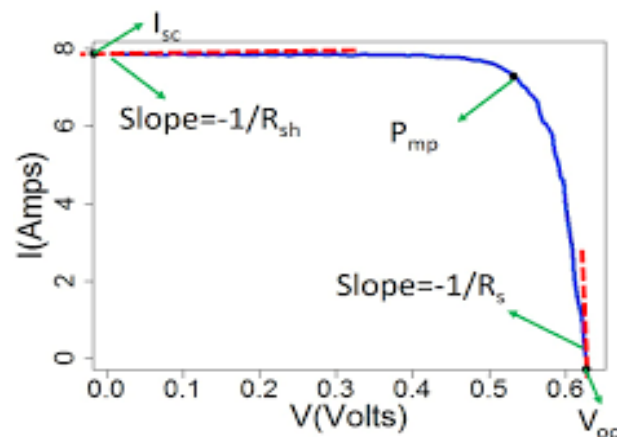

Figure 2.5.2: I-V curve of solar panel

## 2.3 Compare and Contrast

Today, the rural people of Bangladesh are in desperate need of Solar LED Street Lighting. In this way, smart solar LED lights to become a sustainable source of clean energy while also saving a substantial amount of money [19].

Most street lighting in the past was sodium-based. It is environmentally harmful. Globally, street lighting is being replaced with LEDs. Currently, vast changes are being made to the lighting industry. Some advantages of solar LED lighting over traditional lighting may raise the eyebrows of the parking lot and municipal managers [20].

These days, solar street lighting systems are becoming more popular among GOB policymakers and decision-makers. A lithium iron phosphate battery is secured in the lighting system's body. In conclusion, solar street lighting ensures the security of society and supports the smart livelihood of Bangladesh's rural and urban communities. As of June 2019, 18850 street lights had been installed [21].

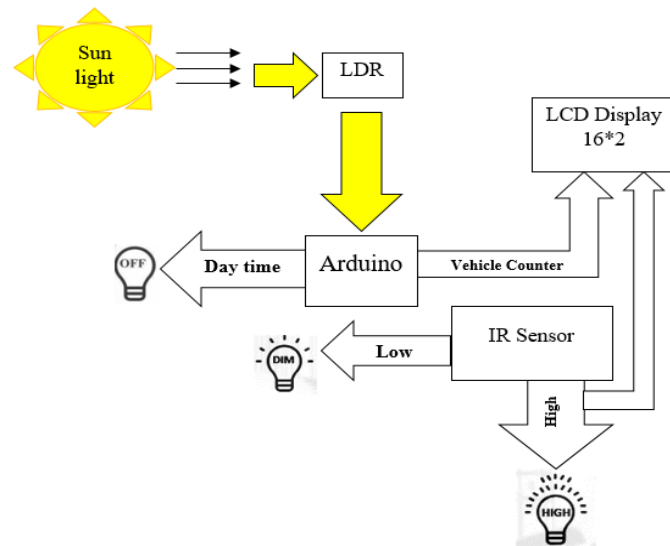

Figure 2.6: Structural design of the solar street lighting system

The street lighting concept is visualized in Figure 2.6 for the sake of simplicity. Arduino receives the intensity value of sunlight from LDR. If the received value is over the threshold level, the LEDs will remain OFF. If it is below the threshold level, the LEDs will remain on. If the IR obstacle detector value is LOW and no object is detected, then the dim LEDs will glow, while if the IR obstacle detector value is HIGH and there is an object detected, then the HIGH LEDs will glow (all of its maximum voltage). In addition, Arduino will demonstrate to the LCD how the IR obstacle detection sensor counts the number of vehicles that crossed the street at night.

## Importance of the Solar Street Lighting System

It is easier to access, provides support to businesses, and strengthens social bonds if solar lights are installed on a city's main streets, on its sidewalks, and in other public areas. As well as reducing insecurity, theft, and assaults, these light solutions offer safety in more isolated areas [22].

Through the use of dynamic lighting profiles, solar street lighting systems automatically adjust lighting intensity throughout the night. This allows it to be friendlier to living ecosystems, including birds whose migratory behavior is affected by light pollution. Lighting can be applied to street corners, gardens, parks, complexes, boundary walls, parking lots, etc. [23].



As solar sensor lights are wireless, thieves will not be able to cut the cable or disconnect them. Solar street lights get their energy from the sun, so the weather and geographical conditions directly influence lighting conditions. The panels will charge the batteries, allowing them to turn on the lights at night. The solar street light is an excellent way to provide safety for drivers and passersby without harming the environment [24].

## **2.4 Summary**

In this segment, we present the related works and solar street overview. And also discussed the types of solar panels and I-V characteristics and solar street lighting systems.

# CHAPTER 3

## MATERIALS AND METHODS

### 3.1 Introduction

Among the components used in this project are LED lights, infrared sensors, solar panels, and other components. To figure out the most effective way to implement the project, a proper schematic diagram is created. Hardware implementation and synchronized server operation define the actual procedure of the research project. The present form of the smart solar-powered street light system was developed through analyzing several pieces of literature based on this criterion. The server control portal for this research was designed using embedded Proteus software. A private server website called adafruit.io was used to host the server.

### 3.2 System Design and Components

#### Block Diagram

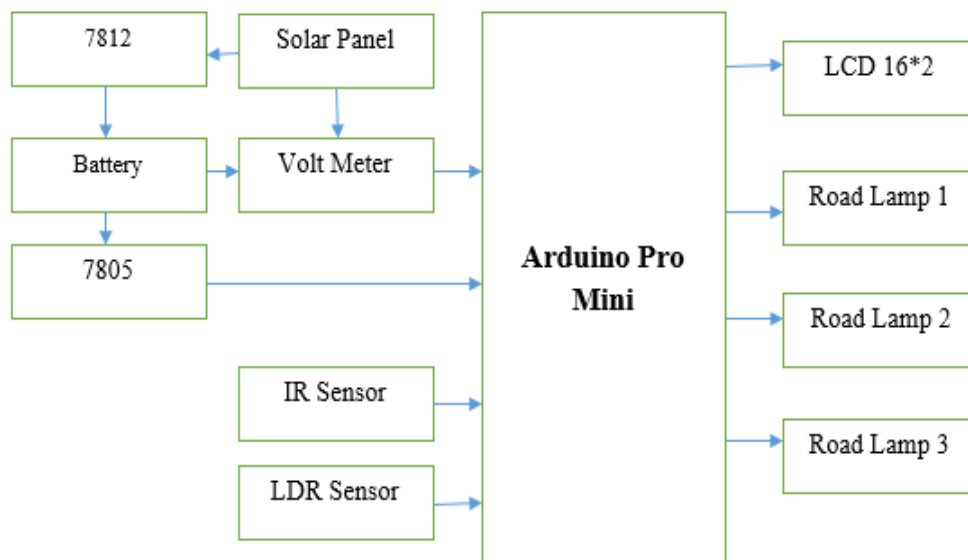

Figure 3.2: Block diagram

## Circuit Diagram

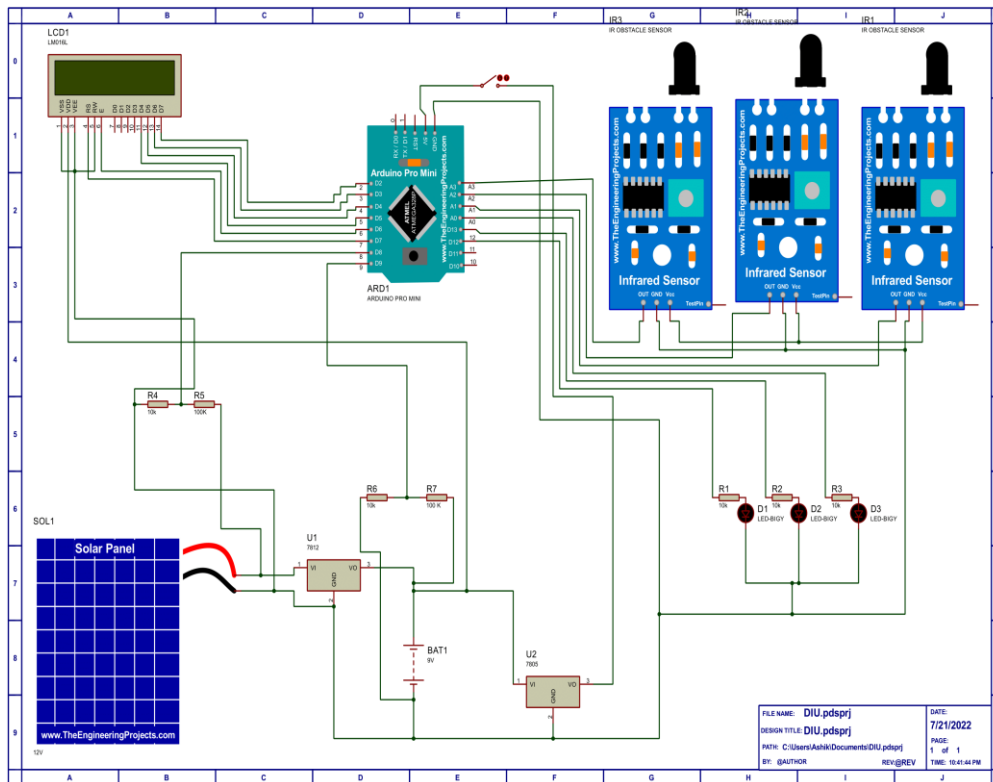

Figure 3.3: Circuit diagram

List of the components:

- Solar
- Battery
- LDR
- LED
- Arduino Pro mini
- Display 16\*2
- IR Sensor

### Arduino Pro Mini

A microcontroller board based on ATmega328; the Arduino Pro Mini is based on a microcontroller's ATmega328. There are holes on the board for mounting pin headers as well as a reset button and resonator on board. In addition, there are 6 analog inputs and 14 digital input/output pins, 6 of which can be used as PWM outputs.

ATmega 168 is used in older versions of the Pro mini rather than ATmega 328. There is no USB port on the Arduino Pro mini. An FTDI adapter is required to program it. Separate programming headers provide FTDI connections with 6 pins. There are no headers included, so it must be soldered to the board first.

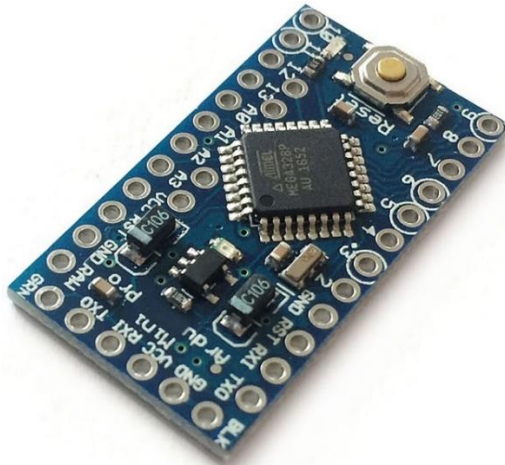

Figure 3.4.1: Arduino Pro Mini

***Specifications:***

**Functioning Voltage:** 5V and 3.3V

**Input Voltage:** 5-12V (5V model) and 3.3-12V (3.3V model)

**Digital I/O Pins:** 14 Pins (6 are PWM output pins)

**Analog Input Pins:** 6 pins

**DC Current per I/O Pin:** 40 mA

**Flash Memory:** 32 kB (0.5 kB is taken by bootloader)

**SRAM:** 2 Kbytes

**EEPROM:** 1 Kbytes

**Clock Speed:** 16 MHz (5V model) and 8 MHz (3.3V model)

Table 3.4.1: ARDUINO Pro Mini Pinout Configuration

Pin Group	Pin Name	Description
POWER SOURCE	VCC, GND, and RAW	VCC - Connected to +5V or +3.3V GND–Connected to Ground RAW – Connected to Unregulated power supply 5+V to +12V
Communication INTERFACE	UART Interface(RXD, TXD) SPI Interface(MOSI, MISO, SCK, SS ) TWI Interface(SDA, SCL)	UART (Universal Asynchronous Receiver Transmitter) Interface can be used to program PRO MINI SPI (Serial Peripheral Interface) Interface can be used to program PRO MINI TWI (Two Wire Interface) Interface can be used to connect peripherals.
INPUT-OUTPUT PINS	PD0 to PD7 (8 pins of PORTD) PB0 to PB5 (6 pins of PORTB) PC0 to PC6 (7 pins of PORTC) ADC6 and ADC7 (2 additional pins)	They serve many purposes, but they can be classified as data I/O pins.
ANALOG to DIGITAL CONVERTER	ADC0, ADC1, ADC2,...ADC7	They can be used for analog input and feature 10-bit resolution.
PWM	OC0A,OC0B,OC1A,OC1B,OC2A,OC2B	It provides PWM (Pulse Width Modulation) outputs and 8-bit resolution.
RESET	RESET	Resets the controller.
EXTERNAL INTERRUPTS	T0 and T1	Hardware interrupts are provided by these two pins.
ANALOG COMPARATOR	AIN0 and AIN1	An internal comparator connects these two pins.

## Battery

The solar panel generates electricity that is stored in batteries. In the daytime, solar panels generate electricity that is supplied to the battery or load. The batteries will provide stable energy to the load when the solar power is insufficient to meet the load demand. Rechargeable batteries fall into three categories:

### i. Lead-Acid (LA) Battery

Despite their low price and maturity in technology, these batteries are the greatest usually used in solar-powered systems. To extend their lifespan, they can only be used using a low depth of discharge (DOD). This is typically between 20% and 50%. Lead-Acid batteries come in two different types. These include flooded batteries and maintenance-free VRLA batteries.

### ii. Nickel-Cadmium (Ni-Cad) Battery

Nickel-Cadmium batteries (Ni-Cd) are expensive, and Cadmium must be disposed of safely. The high cost and limited availability of Ni-Cd batteries prevent them from being widely used in solar-powered systems, despite their benefits over Lead-Acid batteries, for instance, lengthier life spans, and acceptance for higher release rates.

### iii. Lithium-Ion (LI) or Lithium-Polymer (LP) Battery

For solar-powered systems, lithium batteries are considered the future. The great precise energy, the excessive DOD percentage, and the number of charging cycles all contribute to this. Although they are still not as popular as LA-type batteries due to their higher cost.

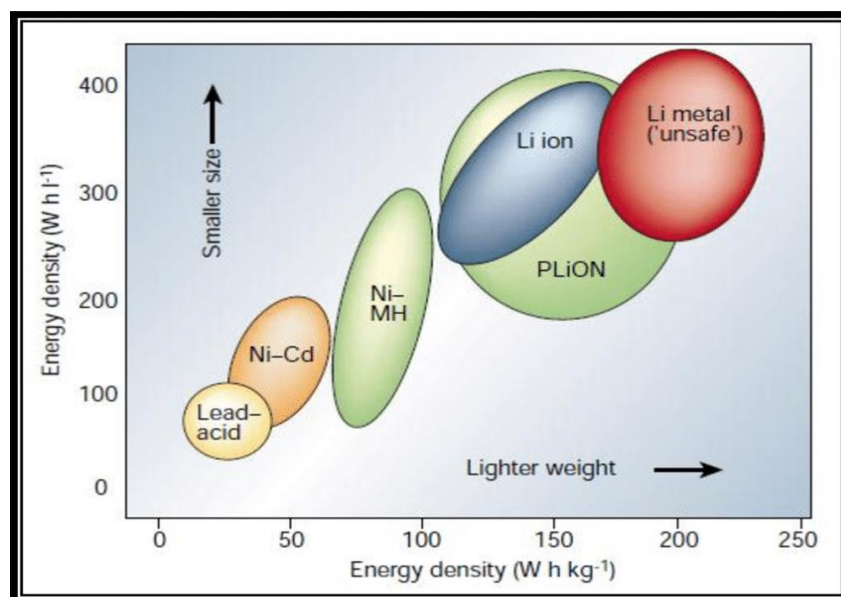

Figure 3.4.2: Comparison of dissimilar battery technologies

## LDR

Light-dependent resistors, or LDRs, are light-detecting sensors included in solar track designs that include photodiodes, phototransistors, and LDRs. LDRs comprise semiconductor materials with high resistance. LDR is used in the greatest types of electronics and also is widely recycled. The LDR can be used for street lamps, outdoor lighting, and several home appliances. The light sensor circuit helps with switching offloads built on daylight's strength with the aid of a light sensor. When light falls on the resistor during daylight, it causes the resistance to change. The light rays strike the photovoltaic panel, which is embedded in a photovoltaic panel. Each resistor has a different function and resistance.

In an electronics project or circuit, LDR makes the project more effective. This is because LDR parts are effortlessly obtainable, also the precision of this circuit is much better than that of other circuits. The circuit is very energy efficient. CdS sensors have zigzag lines that decrease resistance as light falls on them.

A photoresistor can be intrinsic or extrinsic, depending on the material used. Typically, intrinsic photo resistors consist of pure semiconductor devices such as silicon and germanium. A resistor's number of carriers is increased when light falls on the intrinsic photoresistors. Due to this process, electrons are excited from the valence band to the conduction band. The intrinsic photoresistor is doped with impurities. A layer of energy is created above the valence band due to these impurities.

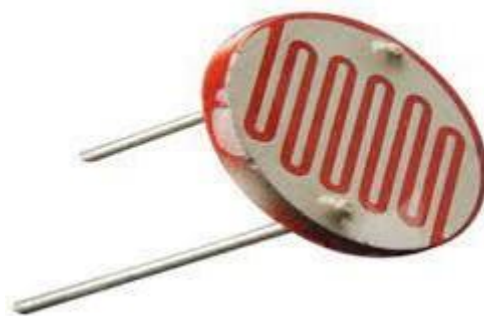

Figure 3.4.3: LDR

## Functioning Principle of LDR

The light-dependent resistor operates on the principle of photoconductivity. A photoconductor increases its conductivity when light is absorbed via the material. Photons on semiconductor materials excite electrons in the valence band to the conduction band. The incident light photons should have higher energy than the bandgap in the semiconductor material for electrons to jump from the valence band to the conduction band.

In an electrical circuit, the device begins to generate more and more current as the circuit is closed. As a result, the device's resistance has decreased. Free electrons or holes conduct electricity, resulting in a reduction of resistance ( $< 1$  Kilo ohm). The light-dependent resistor operates on this principle. Resistance relates to illumination through this equation:

$$R = A.E \quad (1)$$

Where,

E=Illumination (flux).

R= Resistance (Ohms)

A= Constants

The value of A relies on the CdS employed and the built-up progression. Values frequently range between 0.7 and 0.9.

## LED

Two-lead semiconductor light emitters are light-emitting diodes (LEDs). LEDs are special types of diodes that share several electrical properties with P-N junction diodes. In this way, LEDs allow current to flow through them in one direction but block current flowing through them in the other direction. Normally, LEDs occupy a tiny space, less than one millimeter squared. P-N junction diodes are used in lighting emitting diodes. Specially doped semiconductors make up this type of diode. Light-emitting diodes emit light in the forward direction.





Figure 3.4.4: LED

It is simply called a diode when it emits light. The electrons and holes move rapidly across the junction when it is forward-biased, so they are constantly combining, removing one another. The electrons combine with holes as soon as they move from n-type silicon to p-type silicon, then they disappear. The electron stabilizes the atom and emits a tiny photon of light in the form of a small burst of energy.

### LCD Display 16\*2

16\*2 LCD is the LCD most often connected to an Arduino Mini. There are 16 characters per line by 2 lines, and LCD is increasingly replacing LED in recent years. The good news is that a very prevalent standard occurs which enables us to interconnect with most LCDs, irrespective of their manufacturer. An LCD is connected directly to an HD44780U chip that receives data from an external source and speaks directly with it.



Figure 3.4.5: LCD

The 44780 standard specifies 3 control lines along with 4 or 8 I/O lines for the data bus. The LCD can be configured to function using a 4-bit or an 8-bit data bus. For a 4-bit data bus, an LCD requires 7 data lines (3 control lines plus 4 lines for the data bus). An LCD with an 8-bit data bus will need a total of 11 data lines, including three control lines and eight lines for the data bus.

## Features

- Display data RAM
- Character generator ROM
- 160 different 57 dot matrix character patterns.
- The microprocessor can access display data RAM and character generator RAM.
- Numerous instruction.
- Clear Display, Cursor Home, Display ON/OFF, and Cursor ON/OFF, Blink Character, Cursor Shift.
- The built-in reset circuit is triggered at power ON.

Table 3.4.5: Pin symbol description

<b>PIN No</b>	<b>Symbol</b>	<b>Function</b>
1	VSS	GND
2	VDD	+5V
3	V0	Contrast adjustment
4	RS	H/L Register select signal
5	R/W	H/L Read/write signal
6	E	H/L Enable signal
7	DB0	H/L Data bus line
8	DB1	H/L Data bus line
9	DB2	H/L Data bus line
10	DB3	H/L Data bus line
11	DB4	H/L Data bus line

12	DB5	H/L Data bus line
13	DB6	H/L Data bus line
14	DB7	H/L Data bus line
15	A	+4.2V for LED
16	K	Power supply for BKL (0V)

### Logic Status on control lines

- E- 0 Access to LCD Disabled
- -1 Access to LCD enabled
- R/W – 0 Writing data to LCD
- 1 Reading data from LCD
- RS – 0 Instructions

### Writing data to the LCD

- Set R/W bit to low
- Set RS bit to logic 0 or 1
- Set data to data lines
- Set E line to high
- Set E line to low

### Read data from data lines

- Set R/W slightly too high
- Set RS bit to logic 0 or 1
- Set data to data lines
- Set E line to high
- Set E line to low

### IR Sensor

Infrared sensors can detect invisible radiation that our eyes cannot see. According to

the amount of IR light that passes through a photodiode, the output voltages and resistances will change. When IR light strikes the emitter, the LED (Light Emitting Diode) emits IR light, while the detector (IR photodiode) catches the IR light.

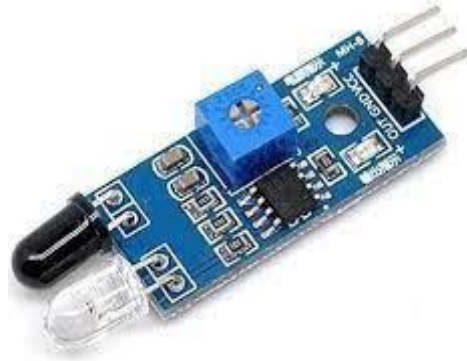

Figure 3.4.6: IR Sensor

The use of IR technology varies among industries. To receive the signals transmitted from the remote control, TVs utilize an IR sensor. IR sensors are known for being low-power, simple, and convenient to use. Humans cannot see IR signals. The electromagnetic spectrum contains infrared radiation, which occurs in the visible and microwave spectrums.

The typical wavelengths of these waves are between  $0.7\mu\text{m}$  and  $1000\mu\text{m}$ . IR comes in three generations, near-IR, mid-IR, and far-infrared. The wavelength ranges from  $0.75\text{-}3\mu\text{m}$  for the near-IR region,  $3\text{-}6\mu\text{m}$  for the mid-infrared region, and more than  $6\mu\text{m}$  for the far IR region.

Electronic devices emit heat to the sense elements of their surroundings. IR sensors can detect motion and measure the heat of objects. It is called an active IR sensor since it radiates IR radiation instead of measuring it. Passive IR sensors only pick up IR radiation. There are many types of thermal radiation emitted from objects in the infrared spectrum.

### **Operational Principle of IR**

Transmitters that emit IR radiation include IR LEDs. There is no visible radiation radiating from this LED, unlike a standard LED. Transmitters transmit IR radiation to infrared receivers. Photodiodes are used for infrared receivers. Because an IR photodiode detects

only IR radiation, they are different from conventional photodiodes. Voltage, wavelength, packaging, etc., all determine the type of infrared receiver.

If it is combined with an IR transmitter and receiver, then the wavelength of the receiver must equal the wavelength of the transmitter. LEDs transmit light, while photodiodes receive it. An infrared photodiode responds to infrared light emanating from an infrared LED. To measure the resistance of a photodiode and the change in output voltage, it is proportional to the infrared light obtained. IR sensors operate on this concept.

The infrared transmitter emits light and then arrives at an object, which reflects some of that light to the receiver. The IR receiver can decide the sensor output based on the intensity of the response.

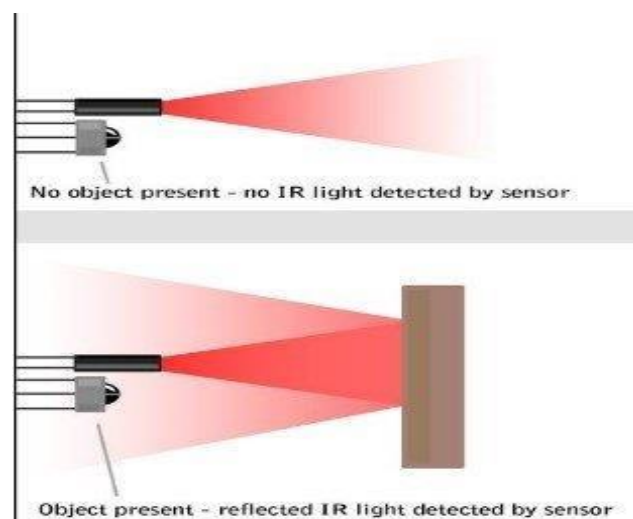

Figure 3.4.6.1: IR sensor operational principle

## Types of IR Sensors

- **Active IR Sensor**

It consists of both the transmitter and the receiver. Light-emitting diodes are commonly used as sources of illumination. Infrared sensors employing LEDs are not imaging sensors, while imaging infrared sensors employ laser diodes.

Radiation is used to transmit and receive energy from these sensors. Further, the signal processor can be used to get the necessary information. Among the active

infrared sensors are reflectance and break beam sensors.

- **Passive IR Sensor**

A passive infrared sensor only includes a detector, but not a transmitter. The sensors are connected to IR sources or transmitters. Using infrared receivers, it emits energy and detects it. Signals are then processed with a signal processor to gain the required information.

Pyroelectric detectors, bolometers, and thermocouple-thermopile sensors are a few examples of this type of sensor. Thermal IR sensors and quantum IR sensors are two types of sensors. Thermal IR sensors do not rely on wavelength. Heat is the source of their power. The response time and detection time of these sensors are slow. This sensor provides a fast response time and high detection accuracy depending on the wavelength. It requires regular cooling for precise measurements.

### **IR Sensor Circuit Diagram**

An IR sensor circuit is the simplest type of sensor segment in an electronic apparatus. An analogous sensor is one of the common applications of real-time monitoring which is capable of detecting obstacles, similar to human vision. This circuit encloses the subsequent apparatuses

- LM358 IC 2 IR transmitter and receiver pair
- Resistors of the range of kilo-ohms.
- Variable resistors.
- LED (Light Emitting Diode).

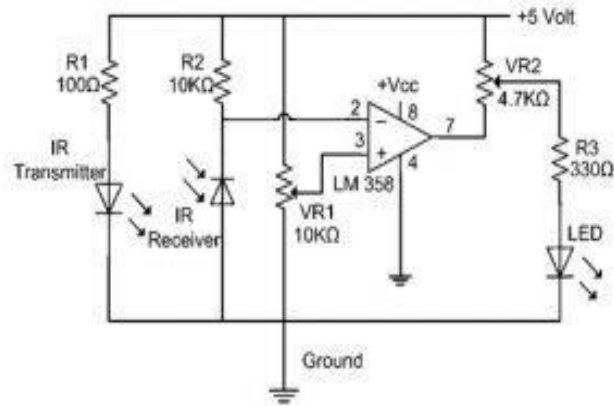

Figure 3.4.6.3: IR Sensor Circuit Illustration

As part of this project, an IR sensor in the transmitter section transmits continuous IR rays to a receiver module. Receiving IR rays changes the IR output terminal of the receiver. To utilize the output, a comparator circuit can be fed into the output since it cannot be analyzed as such. Comparator circuit using LM 339 operational amplifier (op-amp). The potential at the inverting input of the comparator IC (LM339) is higher when the IR receiver does not receive a signal. The LED does not glow because the comparator output is low.

The potential at the inverting input of the IR receiver module goes low when it receives a signal. The comparator (LM 339) output thus rises high and the LED begins to glow. IR LED Devices such as Photodiodes and normal LEDs require a minimum of 10 mA current to pass through the resistors R1 (100), R2 (10k), and R3 (330). Resistor VR2 (preset=5k) is used to adjust the output terminals. To set the circuit diagram's sensitivity, use resistor VR1 (preset=10k).

### 3.3 Design Analysis

#### Flow Chart

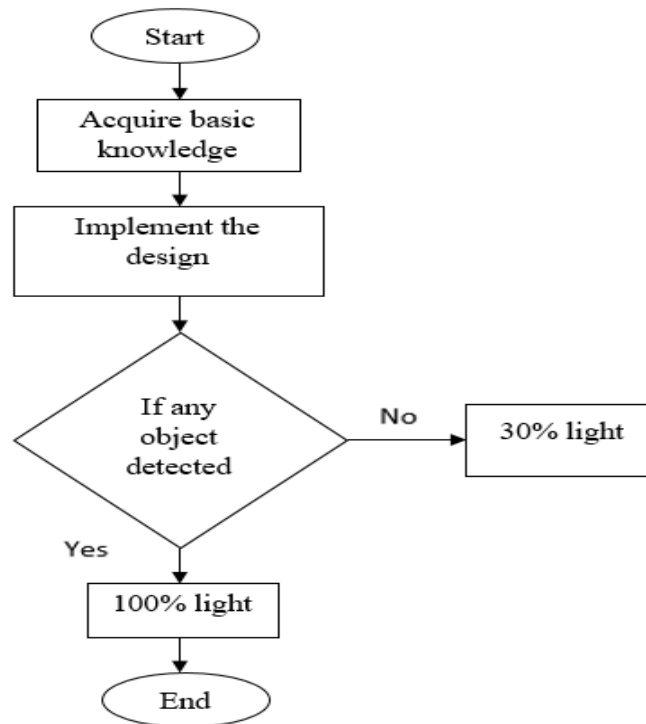

Figure 3.5: Flow chart

### 3.4 Summery

Solar panels are used to generate electricity during the day, which is stored in a battery at night. The light sensor sends commands to the Arduino controller from dusk to dawn.

According to the program, it turns on the light when there is no object beneath the streetlight at 40% of its maximum intensity. An Arduino is set to increase the brightness to 100% if any person or vehicle passes a nearby streetlight. Upon expiration of the preset time and if there is no object detected, the intensity gradually decreases to 40%.

LDR will send a command to Arduino in the morning and turn off the street light. Battery-operated streetlights normally operate with electricity stored in them. Cloudy weather conditions will automatically switch streetlights to utility power if the battery is not sufficiently charged.



## **CHAPTER 4**

### **RESULTS AND DISCUSSIONS**

#### **4.1 Results**

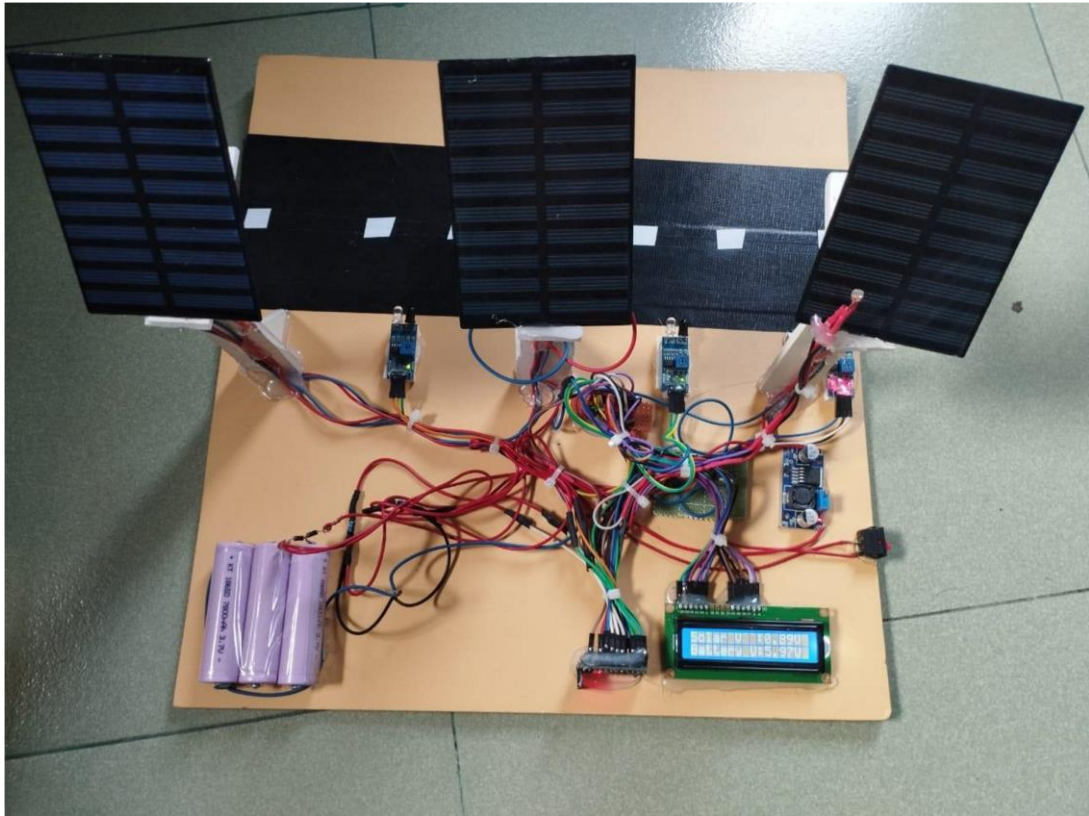

Figure 4.1: The picture of the full project

Here is the picture of the entire smart streetlight control system.

## 4.2 Outcome Analysis and Discussions



Figure 4.2.1: Display

Figure 4.2.1 shows how many voltages come from solar and how many voltages are there in the battery.

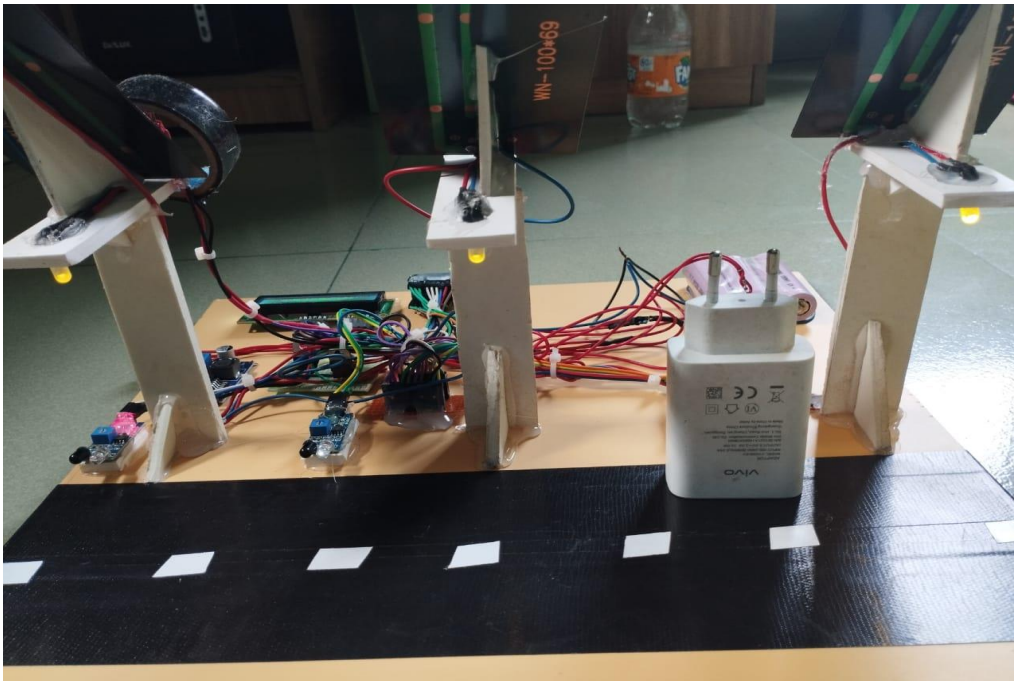

Figure 4.2.2: Object sensing at 3 no sensor

When an object is coming in front of the 3<sup>rd</sup> sensor, the 3<sup>rd</sup> road light gives 100% light and the remaining 1<sup>st</sup> and 2<sup>nd</sup> light gives 40% light.

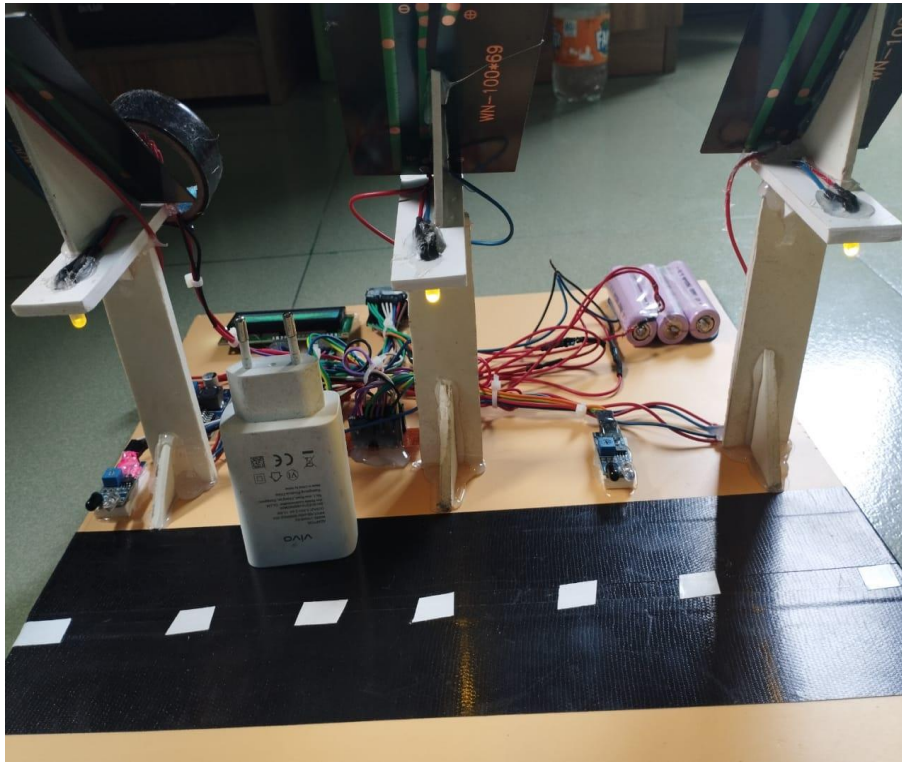

Figure 4.2.3: Object sensing at 2 no sensor

When an object is coming in front of the 2<sup>nd</sup> sensor, the 2<sup>nd</sup> road light gives 100% light and the remaining 1<sup>st</sup> and 3<sup>rd</sup> lights are providing 40% light.

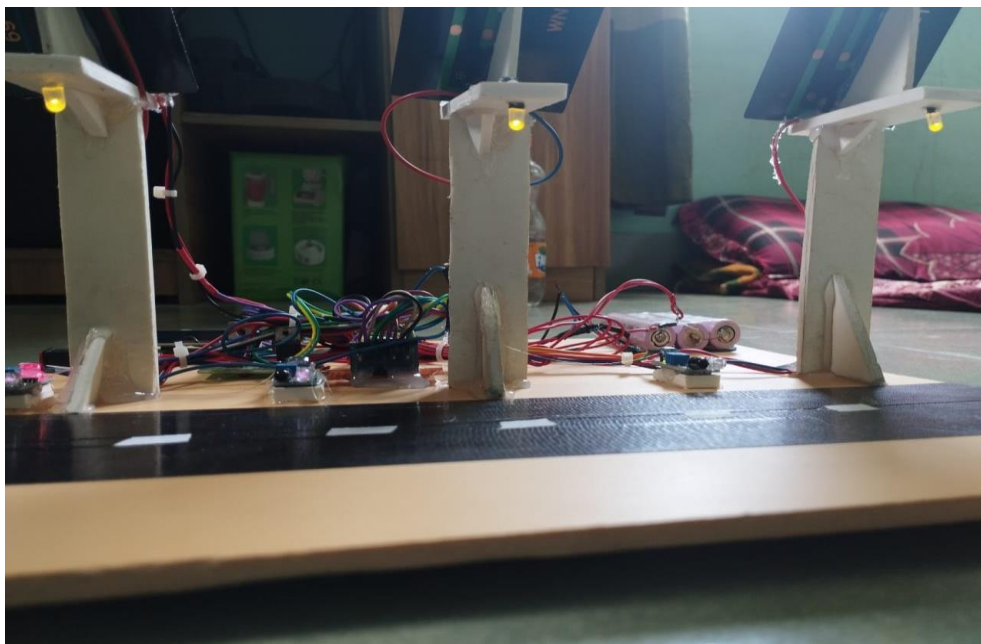

Figure 4.2.4: Object sensing at 1 no sensor

When an object is coming in front of the 1<sup>st</sup> sensor, the 1<sup>st</sup> road light gives 100% light and the remaining 2<sup>nd</sup> and 3<sup>rd</sup> lights are providing 40% light.

# **CHAPTER 5**

## **PROJECT MANAGEMENT**

### **5.1 Resources and Cost Management**

The Proteus software application allows you to model and simulate virtual systems and circuits. A complete microcontroller-based design can be co-simulated using the SPICE mixed-mode circuit simulator, animated components, and microprocessor models. Besides simulating microcontroller interaction, Proteus can also simulate the interaction between analog and digital electronics attached to the microcontroller. All peripherals present on supported processors are emulated, including input/output ports, interrupts, timers, USARTs, etc. Math & Scientific Tools is a category of business programs that includes Proteus a free trial software.

#### **Advantages**

- Multiple outcomes can be derived from one simulation setup by varying the conditions and investigating the outcomes.
- High voltage circuits can be investigated without exposing oneself to dangerous electricity, and one can learn how they behave in critical situations
- It is cost-effective. Circuit simulation allows you to perform tests you would not be able to conduct if you had to purchase different kinds of electronic components for each test. It's possible to perform hundreds and thousands of tests with the one-time purchase of circuit simulation software.
- It is possible to accelerate the design process and analyze circuit behavior quickly through circuit simulation.

#### **Disadvantages**

- Time, effort, and money would be wasted in the simulation if the results obtained from the simulation didn't correspond with the real-life results.

- Experts in electronic circuit simulation software and the concepts of electronic circuit design are required for circuit simulation.
- It can be relatively expensive to purchase circuit simulation software. The challenge may not be for big tech companies and academic institutions, but for hobbyists and tech enthusiasts.

Table 5.1: Cost analysis

<b>Serial No</b>	<b>Components name</b>	<b>Price</b>
1	Arduino Pro Mini	520/=
2	LDR	10/=
3	IR Sensor	150/=
4	Solar Panel	700/=
5	Buck Converter	90/=
6	Boost Converter	100/=
7	LED	20/=
8	Battery	300/=
9	LCD 16*2	200/=
10	Wires and Others	400/=
	<b>Total</b>	<b>2490/=</b>

## 5.2 Lesson Learned

Advantages of solar streetlights:

- **Simple installation**

Without complex new wiring, solar street lights are convenient and simple to install. Concrete and batteries are the only components needed. It doesn't require various employment forces, materials, or economic wealth.

- **Saves energy and is environmentally friendly**

Solar street lights convert sunlight into electricity deprived of requiring electricity. It produces no dust, contamination, or radioactivity according to current ecological protection perceptions.



- **Safe and resilient**

Traditional street lights may have hidden safety hazards due to faulty construction, aging materials, and power supply disruptions; while a solar street light does not use alternating current, so there are no hidden dangers associated with it. With today's solar modules, the manufacturing process has matured enough to provide long-term stability. These modules could also last for decades.

- **Low maintenance costs and high technology**

In conjunction with a solar charge controller, the solar street light can regulate the light intensity depending on the illumination of natural light and the demands of the people. Traditional street lights are expensive to maintain in remote areas. Despite this, solar streetlights only need to be inspected cyclically, so they are relatively cheap to maintain.

The applications of solar streetlights are

- **Airport Lighting**

Solar lights are popular at airports because they require no electricity and are easy to install. A runway is illuminated with LED lights that can be moved from one location to another. However, maintenance only needs to be done every seven years. Aircraft operation at night is made safer with these lights.

- **Highway and roadway lighting**

Also, they are very easy to install. Because these lights do not require any external wiring, the risk of accidents is minimized. In remote areas with no electricity, these lights can be easily installed. The LED Streetlights enable pedestrians and drivers to see clearly. The LED light system beautifies urban areas without polluting the environment at night.

- **Park and Playground lighting**

In parks and playgrounds, solar-powered lighting systems provide light for signs, trails, pavilions, and parking lots. Unlike conventional lights, they are not connected to a grid, so they can be installed anywhere in the park that requires adequate lighting.



In both cases, the lights are for the safety of children playing after dark as well as to secure the area for the officials. Several reasons have led to most soccer matches being conducted at night these days. For this reason, solar LED lights are installed in stadiums and playgrounds to provide high-powered illumination. To play sports, a playground needs high-power lighting, called floodlights, which can be achieved through solar panels at a low cost and with minimal maintenance.

- **Lighting for industries and businesses**

Unlike other lighting systems, solar LED lights provide continuous illumination for 3 days without any recharging. For outdoor lighting, industrial areas require more electricity due to their size. As a result of the installation of solar lights, electric wire costs will decrease, and maintenance costs will also decrease.

- **Outdoor security lighting**

Solar energy is used to power solar-powered security lights. Solar-powered security systems are ideal for nighttime use since they do not require electricity when the sun is shining. Lighting is turned on when motion is detected. They also provide reliable lighting when the skies are hazy. Solar power applications will expand due to the traditional energy shortage. Recently, photovoltaics has become a rapidly growing industry. The solar street light has been applied to many different situations. There are also some restraining factors in solar street lighting's implementation and promotion.

- **Initially large investment**

Input costs are one factor to consider. Solar street lights require a large initial investment. Solar street lights with the same efficiency are three or four times more expensive than traditional street lights.

- **Storage batteries have a limited-service life**

Most common storage batteries cannot be fully charged in a year or even half a year. There is the possibility that the charging efficiency of some of them will decline to 50%, which will affect the lighting conditions during rainy days. To install a solar street light, it is crucial to choose a high-quality battery.

## **CHAPTER 6**

### **IMPACT ASSESSMENT OF THE PROJECT**

#### **6.1 Economical, Societal, and Global Impact**

Product failures or malfunctions during use may not benefit stakeholders. Instances of standard safety measures being violated may result in physical harm. A direct stakeholder contributes an amount directly to a project, while an indirect stakeholder pays taxes and benefits from the project's use. This product will result in better budgeting and distribution of tax funds for other municipal projects resulting from cost savings. The federal government decides on the distribution of funds. Uneven distribution of a product creates inequality in an area.

Most of the project's funding comes from state governments. Promoting and implementing our device in large areas helps reduce electrical utility costs. State governments and advisors are direct stakeholders. People who use the product directly, such as pedestrians, are indirect stakeholders. When we provide adequate service and reduce emissions in a commercial market, our direct stakeholders are financially rewarded. Likewise, pedestrians can conduct outdoor activities during the night hours due to our technology, resulting in social benefits for them.

Building energy-efficient cities will be the starting point for environmental governance in the aftermath of COVID-19. During the analysis period 2020 to 2027, solar street lighting is expected to reach US\$ 14 billion, representing a 14.7% CAGR post-COVID-19. Clean energy, government initiatives, and the massive adoption of these systems will lead to the growth of this industry. A lot of outdoor lighting systems use solar photovoltaic panels for capturing and storing solar energy. The market is growing due to ambitious programs to curb greenhouse gas emissions and

promote sustainable development. In addition, government subsidies aid the development of clean energy sources.

## **6.2 Environmental and Ethical Issues**

Proper manufacturing and device security are required to meet standard health and safety standards. The device's design adheres to the Bureau of Street Light Design. Devices that are poorly set up can fall from the post and injure passersby. It is also vitally important that batteries are neatly and securely secured. As a result of implementing the product, the environment is better utilized. It is a solar street lamp that does not use the utility grid for power. All of these lights are self-sufficient and have different conductivity times. When less energy is used by the utility company that supplies the city with energy, the city's environment becomes more efficient. Instead of fossil fuels, solar energy provides almost unlimited energy. Solar power in a particular area is what powers the product.

We did not take any misrepresent or distort data. Never keep our mind in any inclination to exploratory design, information analysis, data elucidation, and other angles of research. We always attempt to maintain a strategic distance from careless mistakes and negligence and try to keep great records of inquiring about our project work. Day by day we are trying to Keep up and move forward with our possess design and mastery through long-lasting education and learning and have taken steps to advance our plan to science as an entire.

## **6.3 Utilization of Existing Standards**

The manufacturing process does not pose any significant challenges. It is based on commercially available parts and has reproducible documentation. A minor project issue is the size and layout of components. Additionally, component tolerances also compromise sensor accuracy and system efficiency, affecting successful product operation.

Weather conditions vary, negatively affecting the device. Rainy days and overcast skies interfere with the operation of the device. Solar-Powered LED Street Lamp with Sun-Tracking possesses a waterproof design that protects against moisture and its outer housing is designed to withstand high winds. Solar energy is used to power the project's lights and motion apparatus, reducing the public's reliance on the power company's energy reserves.

## **6.4 Health Concerns**

Due to its application and light emission, the product may affect other animals. The placement of lampposts may affect bird counts. For bird species' safety, glare and reflection reduction occurs by angling and focusing the LED light downwards, decreasing overhead light pollution.

Body damage and device damage can result from tampering with the battery or microcontroller. Other species are taken into account in the design of the device. It's designed so that there are no exposed wires or sharp edges that might harm animals that interfere with it.

## **6.5 Technical Challenges**

During the solar LED street light design, typically purity is always a first and foremost challenge. Whether the desired material is pure enough to produce the expected results. After that design fabrication, a complex design of any proposed solar LED can be difficult. It will be more challenging for any industry to store power for this project because of the weather. Another challenge is maintaining sensor calibration by mitigating real-life losses as much as possible. Although C programming gives access to design with real-life phenomena, still it is a virtual operation. So, real-life losses will be the biggest challenge. Aftermath, we can say that the more complex the design is the great impact will befall the challenges to implement it.

## **CHAPTER 7**

### **CONCLUSIONS AND RECOMMENDATIONS**

#### **7.1 Conclusion**

During the night and at dawn, a solar-powered streetlight provides illumination beside streets, houses, also roads to strengthen life and property security. By providing an alternative source of electricity to power streetlights, this work helps reduce pressure on the national grid because of the inconsistencies surrounding fossil fuel generation. As a result of the study, solar panels (photovoltaic modules) are very cost-effective ways to produce electricity straight from the sun unused to emitting sound or shaking.

There is currently a major barrier to the adoption of solar LED street lights, due to the initial investment required. Despite this, solar cells are becoming more efficient while their prices are decreasing. LED lighting is becoming more efficient while also becoming more affordable.

#### **7.2 Future Recommendations**

During the devastating aftermath of the COVID-19 pandemic, this research and development were conducted and developed. It has some limitations, such as the 3-sec delay to turn on the lights once the LDR 46 value falls below the threshold. Furthermore, a dedicated domain must be created to avoid such issues and resolve the issues with the server. It is possible to build a new system connecting to the GSM so that it can send an automated text message to authorized contact numbers when a

problem occurs. Further improvements to this criterion can provide an automatic lighting system with sufficient precision and pinpoint accuracy since enough solar power is being stored, the electric vehicle can be charged later with some solar power stored at a station. Electricity can be used at home.

## REFERENCES

- [1] X. Long, R. Liao, and J. Zhou, "Development of street lighting system-based novel high-brightness LED modules," *Optoelectronics, IET*, Vol.3, no.1, pp.40-46, February 2009.
- [2] E. Adetiba, V. O. Matthews, A. A. Awelewa, I. A. Samuel, and Badejo, "Automatic Electrical Appliances Control Panel Based on Infrared and Wi-Fi: A Framework for Electrical Energy Conservation," *International Journal of Scientific & Engineering Research*, Vol. 2, no. 7, pp. 1-7, 2011.
- [3] S. K. Cho, and V. Dhingra, "Street Lighting Control Based on LonWorks Power Line Communication," *IEEE International Symposium on Power Line Communications and Its Applications*, Jeju City, pp. 396- 398, April 2008.
- [4] X. Long, and J. Zhou, "An intelligent driver for Light Emitting Diode Street Lighting," Automation Congress, 2008. *WAC 2008. World*, vol., no., pp.1-5, Sept. 28 2008-Oct. 2 2008.
- [5] Y. Y. Zhang, X. F. Lu, R. Cai, J. Gong, S. Liu, and J. Y. Bao, "Design of an Intelligent Solar-LED Streetlight," *Applied Mechanics and Materials*, Vol. 548-549, pp. 873-879, Apr 2014.
- [6] A. Jain, and C. Nagarajan, "Efficient Control Algorithm for a Smart Solar Street Light," *2015 9th International Conference on Next Generation Mobile Applications, Services and Technologies*, Sept 2015.
- [7] A. Patil, V. Thumar, and P. Bhandare, "Dolor Solis: Smart Solar Street Lights," *International Research Journal of Engineering and Technology (IRJET)*, Vol. 06, no. 02, Feb 2019.
- [8] M. K. Nallapaneni, K. S. Anup, and K. R. Vinay, "Fossil fuel to solar power: A sustainable technical design for street lighting in Fugar city, Nigeria," *Procedia Computer Science*, Vol. 93, pp. 956- 966, 2016.
- [9] M. N. Bhairi, S. S. Kangle, M. S. Edake, B. S. Madgundi, and V. B. Bhosale, "Design and implementation of smart solar LED street light," *2017 International Conference on Trends in Electronics and Informatics (ICEI)*, May 2017.
- [10] B. G. Kim, J. M. Lee, and Y. K. Kim, "Development of Current Control System for Solar LED Street Light System," *International Journal of advanced smart convergence*, Vol. 1, no. 1, pp.52-56, May 2012.

- [11] W. M. Galita, "Development of a Smart Solar-Powered LED Street Lighting System for Greener Community," *Scientific Research*, Vol. 02, no. 03, Mar 2015.
- [12] A. A. Okandeji, Z.O. Jagun, M. B. Olajide, M. T. Kabir, and F. Onaifo, "DESIGN AND IMPLEMENTATION OF SOLAR STREET LIGHT FOR SCARCELY ELECTRIFIED AREAS," *ARID ZONE JOURNAL OF ENGINEERING, TECHNOLOGY & ENVIRONMENT (AZOJETE)*, Vol. 16, no. 3, pp. 543-560, Sept 2020.
- [13] Solar Cells, available at <<<https://www.britannica.com/technology/solar-cell>>>, last accessed on 30-06-2022 at 12:05 AM.
- [14] G. P. Smestad, F. C. Krebs, C. M. Lampert, C. G. Granqvist, K.L. Chopra, X. Mathew, and H. Takakura, "Reporting solar cell efficiencies in Solar Energy Materials and Solar Cells," *Solar Energy Materials and Solar Cells*, Vol. 92, no. 4, pp. 371-373, Apr 2008.
- [15] C. A. Reynaud, R. Clerc, P. B. Lechêne, M. Hébert, A. Cazier, and A. C. Arias, "Evaluation of indoor photovoltaic power production under directional and diffuse lighting conditions," *Solar Energy Materials and Solar Cell*, Vol. 200, pp. 110010, Sept 2019.
- [16] Solar Street Light, available at <<[https://en.wikipedia.org/wiki/Solar\\_street\\_light](https://en.wikipedia.org/wiki/Solar_street_light)>>, last accessed on 30-06-2022 at 01:55 AM.
- [17] The Solar Street Light Working Principle and Its Components, available at <<<https://solar-led-street-light.com/solar-street-light-working-principle/>>> last accessed on 30-06-2022 at 02:39 AM.
- [18] Solar Panels, available at <<[https://en.wikipedia.org/wiki/Solar\\_panel](https://en.wikipedia.org/wiki/Solar_panel)>>, last accessed on 30-06-2022 at 02:18 AM.
- [19] O. D. Cota, and N. M. Kumar, "Solar Energy: A Solution for Street Lighting and Water Pumping in Rural Areas of Nigeria," *International Conference on Modelling, Simulation and Control (ICMSC)*, Oct 2015.
- [20] R. Ciriminna, F. Meneguzzo, L. Albanese, and M. Pagliaro, "Solar street lighting: a key technology en route to sustainability," *WIREs Energy Environ* 2017, Jun 2017.
- [21] Solar Street Lighting System, available at <<<https://rdfbd.org/solar-street-lighting-system/>>>, last accessed on 30-06-2022 at 03:14 AM.
- [22] How solar street lighting can promote positive change, available at <<<https://go.sunna-design.com/blog/solar-lighting-positive-change-social-community-environnement#:~:text=Deploying%20solar%20street%20lights%20on,reduce%20insecurity%2C%20theft%20and%20assaults>>> last accessed at 30-06-2022 at 02:31 PM.
- [23] F. Leccese, and Z. Leonowicz, "Intelligent wireless street lighting system," *2012 11th International Conference on Environment and Electrical Engineering*, May 2012.
- [24] W. Sutopo, I. S. Mardikaningsih, R. Zakaria, and A. Ali, "A Model to Improve the Implementation Standards of Street Lighting Based on Solar Energy: A Case Study," *Energies* 2020, Vol. 13, no. 3, pp. 630, Feb 2020.