

Responsive Web Application for DIU NLP Lab

BY

Jubayer Ahmad Shovon

ID: 191-15-12615

AND

Md. Nuray Alam Siddik

ID: 191-15-12424

This Report Presented in Partial Fulfillment of the Requirements for the
Degree of Bachelor of Science in Computer Science and Engineering

Supervised By

Dr. Sheak Rashed Haider Noori

Professor & Associate Head

Department of CSE

Daffodil International University



DAFFODIL INTERNATIONAL UNIVERSITY

DHAKA, BANGLADESH

JANUARY 2023

APPROVAL

This Project titled “**Responsive Web Application for DIU NLP Lab**”, submitted by **Jubayer Ahmad Shovon**, ID: **191-15-12615** and **Md. Nuray Alam Siddik**, ID: **191-15-12424** to the Department of Computer Science and Engineering, Daffodil International University has been accepted as satisfactory for the partial fulfilment of the requirements for the degree of B.Sc. in Computer Science and Engineering and approved as to its style and contents. The presentation has been held on January 28th, 2023.

BOARD OF EXAMINERS

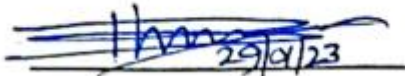

Dr. Touhid Bhuiyan
Professor and Head

Department of Computer Science and Engineering
Faculty of Science & Information Technology
Daffodil International University

Chairman

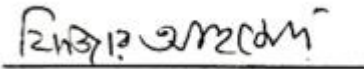

Dr. Fizar Ahmed
Associate Professor

Department of Computer Science and Engineering
Faculty of Science & Information Technology
Daffodil International University

Internal Examiner



Taslima Ferdous Shuva
Assistant Professor

Department of Computer Science and Engineering
Faculty of Science & Information Technology
Daffodil International University

Internal Examiner



Dr. Md Sazzadur Rahman
Associate Professor

Institute of Information Technology
Jahangirnagar University

External Examiner

DECLARATION

We hereby declare that, this project has been done by us under the supervision of **Dr. Sheak Rashed Haider Noori, Professor & Associate Head, Department of CSE** Daffodil International University. We also declare that neither this project nor any part of this project has been submitted elsewhere for award of any degree or diploma.

Supervised by



Dr. Sheak Rashed Haider Noori
Professor & Associate Head
Department of CSE
Daffodil International University

Submitted by:

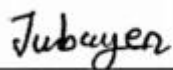

Jubayer Ahmad Shovon
ID: 191-15-12615
Department of CSE
Daffodil International University

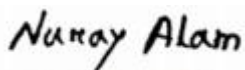

Md. Nuray Alam Siddik
ID: 191-15-12424
Department of CSE
Daffodil International University

ACKNOWLEDGEMENT

First we express our heartiest thanks and gratefulness to almighty God for His divine blessing makes us possible to complete the final year project/internship successfully.

We are really grateful and wish our profound our indebtedness to **Dr. Sheak Rashed Haider Noori, Professor & Associate Head**, Department of CSE Daffodil International University, Dhaka. Deep Knowledge & keen interest of our supervisor in the field of “*Web-based Application*” to carry out this project. His endless patience ,scholarly guidance ,continual encouragement , constant and energetic supervision, constructive criticism , valuable advice ,reading many inferior draft and correcting them at all stage have made it possible to complete this project.

We would like to express our heartiest gratitude to **Pro. Dr. Touhid Bhuiyan, Professor, and Head**, Department of CSE, for his kind help to finish our project and also to other faculty member and the staff of CSE department of Daffodil International University.

We would like to thank our entire course mate in Daffodil International University, who took part in this discuss while completing the course work.

Finally, we must acknowledge with due respect the constant support and patients of our parents.

ABSTRACT

The DIU NLP Lab Web Application is a platform that is designed to help people in the NLP lab at DIU work together more efficiently. It has features that allow users to log in, add information about events and research projects, and see a calendar of upcoming events. The app also has a special section for the person in charge of the lab (the administrator) where they can add users, events, and research projects and approve events that other users have added. The DIU NLP app will benefit the NLP lab because it will make it easier for everyone to stay up-to-date about what is happening in the lab and work together on projects. As a result, this app will make the lab more productive and successful. It will also help the administrator by giving them a way to keep track of everything happening in the lab and ensure everything is running smoothly. Overall, the DIU NLP app will be a great addition to the university because it will help the NLP lab work more efficiently and effectively, leading to better outcomes and more contributions. This project report shows the inner working and the making process of this web-based application.

TABLE OF CONTENTS

CONTENTS	PAGE
Board of examiners	i
Declaration	ii
Acknowledgements	iii
Abstract	iv
CHAPTER	
CHAPTER 1: INTRODUCTION	1-4
1.1 Introduction	1
1.2 Motivation	1
1.3 Objective	2
1.4 Expected Outcome	2
1.5 Project Management	3
1.6 Project Layout	4
CHAPTER 2: BACKGROUND STUDY	5-7
2.1 Preliminary	5
2.2 Related Works	5
2.3 Comparative Analysis	6
2.4 Scope of Problems	6
2.5 Challenges	7
CHAPTER 3: REQUIREMENT SPECIFICATION	8-16
3.1 Business Process Modeling	8
3.2 Requirement Collection & Analysis	8

3.3 Use Case Modeling and Description	12
3.4 Logical Data Model	15
3.5 Design Requirements	16
CHAPTER 4: DESIGN SPECIFICATION	17-23
4.1 Front-end Design	17
4.2 Back-end Design	18
4.3 Interaction Design and User Experience (UX)	20
4.4 Implementation Requirements	23
CHAPTER 5: IMPLEMENTATION AND TESTING	24-32
5.1 Implementation of Database	24
5.2 Implementation of Front-end Design	25
5.3 Testing Implementation	30
5.4 Test Results and Reports	30
CHAPTER 6: IMPACT ON SOCIETY, ENVIRONMENT AND SUSTAINABILITY	33
6.1 Impact on Society	33
6.2 Impact on Environment	33
6.3 Sustainability Plan	33
CHAPTER 7: CONCLUSION AND FUTURE SCOPE	34
7.1 Discussion and Conclusion	34
7.2 Scope for Further Developments	34
REFERENCES	35-36

LIST OF FIGURES

FIGURES	PAGE NO
Figure 3.1: Join Event BPMN Model	8
Figure 3.2: Use case diagram for DIU NLP Lab web app	13
Figure 3.3: Data Schema for DIU NLP Lab web app	15
Figure 4.1: Front end architecture	17
Figure 4.2: Back-end architecture	18
Figure 4.3: Web Scraper Architecture	19
Figure 4.4: Homepage design in Figma	20
Figure 4.5: Homepage in desktop browser	21
Figure 4.6: Home page on mobile browser	22
Figure 5.1: MongoDB Atlas Panel	24
Figure 5.2: Home page	25
Figure 5.3: Research Page	26
Figure 5.4: Peoples Page	27
Figure 5.5: Events Page	28
Figure 5.6: Admin Dashboard	29
Figure 5.7: Login and Sign-Up Page	29
Figure 5.8: GTmetrix report	32

LIST OF TABLES

TABLES	PAGE NO
Table 3.1: Minimum hardware requirement for DIU NLP Lab web app	11
Table 3.2: Recommended hardware requirement for DIU NLP Lab web app	11
Table 3.3: The software requirements for the application.	11
Table 3.4: Frontend package dependencies	11
Table 3.5 Backend package dependencies	12
Table 3.6: Use case description for DIU NLP Lab web app	13
Table 5.1: Taste Case Results	30
Table 5.2: Test Report	32

CHAPTER 1

INTRODUCTION

1.1 Introduction

The DIU NLP Lab web application [1] is developed using the MERN [2] stack (MongoDB [3], Express [4], React.js [5], and Node.js [6]). The MERN stack is a popular choice for building modern web applications due to its simplicity and flexibility. The DIU NLP Lab web app is designed to be a platform for researchers, students, and professionals in the field of natural language processing (NLP [7]) to share their knowledge and collaborate on projects.

The main features of the DIU NLP Lab web application include an event section for sharing events, publication section for research papers, and a resources section for NLP tools and datasets. Users can create their own profiles and join events and search publications.

Overall, the DIU NLP Lab web application is a valuable resource for anyone interested in NLP and provides a platform for researchers and professionals to share their knowledge and collaborate on projects.

1.2 Motivation

It is common for research labs or centers to have a platform to communicate their research and activities to the public. For example, a web application can provide information about the lab's research areas, current and past projects, publications, team members, and any events or seminars the lab hosts or participates in. A web application can also serve as a way for the lab to showcase its work and achievements and to attract potential collaborators, students, and funding sources.

In the case of the DIU NLP Lab, the motivation for creating the web application was to provide information about the lab's research and activities in the natural language processing (NLP) field and promote the lab's contributions to the NLP community. A web application can also be a valuable resource for people interested in learning more about NLP and the work being done at the lab and for researchers and students who may be interested in joining the lab or collaborating on projects.

1.3 Objective

There are several objectives of designing and building Daffodil International University Natural Language Processing (NLP) lab. These are explained briefly:

- Provide a platform for researchers to share and discuss their work: The web app will be a hub for researchers to share and discuss their NLP research, including papers, code, and data.
- Facilitate collaboration and teamwork: The web app could provide tools and features to support research collaboration, such as version control, issue tracking, and project management.
- Educate the public about NLP: The web application is designed to educate the public about NLP, including what it is, how it works, and its various applications.
- Promote the work of the lab: The web app can be used to promote the research and activities of the NLP lab, including events, seminars, and workshops.
- Serve as a resource for NLP researchers: The web application is designed to be a resource for NLP researchers, including providing access to NLP datasets, tools, and other resources.
- Enhance the user experience: The web app is designed to provide a high-quality user experience, including easy navigation, fast loading times, and a responsive design.

1.4 Expected Outcome

The expected outcome of the DIU NLP Lab web application made in the MERN stack is a fully functional, user-friendly web application that allows users to access information about the NLP Lab and its research, events, and resources. The web application is responsive and accessible on a variety of devices and should have a clean, modern design. It has features such as a search bar, easy navigation, and the ability to sign up and register for events. Overall, the web application should effectively serve as a hub for NLP research and information at DIU.

1.5 Project Management

Developing the NLP Lab web app in MERN (MongoDB, Express, React, Node.js) stack involves planning, designing, building, testing, and deploying the app. Here are steps we followed to manage the project:

- Define the project: We clearly define the NLP Lab web application's goals, scope, and deliverables.
- Create a project plan: We developed a timeline and created a project management plan that outlines the tasks, resources.
- Set up a development environment: Install the necessary software and tools for building and testing the NLP Lab web application. We used VSCode [8] editor to write code, git for version control.
- Design the web application: Design the overall architecture of the NLP Lab web application, including the database schema, server-side logic, and client-side user interface.
- Build the application: Write the code for the NLP Lab web application using best practices for coding and testing.
- Test the application: Thoroughly test the application to ensure it works correctly and meets the requirements.
- Deploy the application: Deploy the application to a production environment, such as a cloud platform or dedicated server.
- Monitor and maintain the application: Monitor the performance and stability of the application and address any issues or bugs that arise.
- Effective project management is important to the success of any software development project. It makes sure that the project is completed on time, within budget, and to the required quality standards.

1.6 Report Layout

Chapter one is titled "Introduction." In this chapter, we will discuss the project's Introduction, Motivation, and Objective and also discuss as regards the Expected Outcome.

Chapter two is titled "Background." We discuss the background study we conducted for this project in this section.

The third chapter is called "Requirement Specification," We needed some requirements for this project in our hardware and software. Also, the feature requirements are discussed here.

The fourth chapter is named "Design Specification." We discussed the web application's back-end Design & front-end design, user experience & interaction design, and the implementation requirements.

"Implementation and Testing" is the fifth section of this report. In this section, we will discuss the implementation of the project and the various testing we did to ensure a stable system.

In the "Impact on Society, Environment, and Sustainability" section, which is the sixth chapter, we will talk about the impact of this web-based application on Society and the Environment and also see the Sustainability of this app.

The seventh and last section is "Conclusion and Future Scope." Here, we will talk about the future development scope of the DIU NLP Lab Web Application.

CHAPTER 2

BACKGROUND STUDY

2.1 Preliminary

NLP Lab of Daffodil International University is a great platform we can use to research, explore and share our knowledge. However, to get the facilities of this lab, we need to contact physically going to the university campus. To make this easier, we found a solution. We developed a web application that is dynamic and responsive. Our honorable researchers, faculty, and lab members can interact with many events, papers, and other works through the application. Our user interface and functionalities are very user-friendly, and users always feel comfortable using the application. We developed the application from scratch so that we know all the ins and outs of the application, and it will help us with modification if needed.

2.2 Related Works

NLP is a subset of data science. As data science has become a trendy field in recent years, the interest in NLP also increased. Therefore, we searched for activities on NLP Lab from various universities in Bangladesh and globally. We found that in Bangladesh, SUST and BUET has dedicated NLP site or page. From a global search, Stanford

NLP Group is one of the notable ones.

NLP LAB Site, SUST [9]: The Natural Language Processing Website for Shahjalal University of Science and Technology is built with PHP. It is running on a CentOS server and using Apache server engine software.

Features:

- Teams page
- Publications & Search Functionality
- Ability to Join by filling up a form
- Contact Page

BUET CSE NLP Group [10]: BUET NLP Group's GitHub page showcases the project they are doing. It is a static site.

Features:

- Recent News Update
- Publications
- Ongoing project page
- Teams Information

Stanford NLP Group [11]: The website showcased the university's research on NLP field.

- Features:
- Blog Posts
- Email subscription
- Peoples page
- Papers and books page

2.3 Comparative Analysis

Upon analyzing NLP Lab's website from Bangladesh and around the globe, we found that all of them showcase their work in the NLP field. They all have people's pages and research papers in the NLP field. In addition, some features like blog posts or news updates.

2.4 Scope of Problems

We faced a few problems while developing the web app for the DIU NLP web app. We found that available NLP lab platforms do not provide the proper tools to help one in the NLP field. They only create a little to make people interested in the NLP field. We developed the platform in the MERN stack. While developing, we had to install a specific version of Node.js and React Router. React Router updated from version 5 to version 6, which created a problem for us as we wanted to implement the project with the latest version available, but much was changed in the newer version. Designing the responsive web design was also a problem. As various devices are available now with various screen sizes, testing the app

on all devices was a problem. Deploying the backend is also problematic. We first used Heroku for the backend, but as Heroku shut down free dynos, we moved the backend to Render.

2.5 Challenges

We encountered several challenges when creating a web application for a Natural Language Processing (NLP) lab. Some of these challenges include:

- **Technical challenges:** Building a web application for an NLP lab requires specific technical expertise, particularly in web development and programming. We needed to learn to use various tools and technologies, such as HTML, CSS, JavaScript, and databases.
- **Design challenges:** In addition to the technical aspects of building a web application, we also needed to consider the design and layout of the platform. This includes choosing an appropriate color scheme, font, and layout and ensuring that the app is visually appealing and easy to navigate.
- **Content challenges:** Creating the content for an NLP lab web application can be time-consuming and complex. We needed to decide what information to include on the app and how to present it clearly and concisely. This involved writing text, creating graphics, and collecting and organizing data and research findings.
- **Maintenance challenges:** Once the web application is live, we must ensure that it is regularly updated with new content and information. This can be an ongoing task that requires careful planning and organization.
- **Deployment challenges:** To deploy a MERN app a dedicated server is need. We tried to host it on cPanel but it does not officially support it.

CHAPTER 3

REQUIREMENT SPECIFICATION

3.1 Business Process Modeling

A business procedure model is a flowchart or model used to develop a task or system. An illustration of a business procedure is a mapping idea that specifies the actual flow of information. This approach enables us to get a structural view of a system or device. All developers must construct a business method model before initiating a job or machine. Fig 3.1 shows the BPMN for user join event.

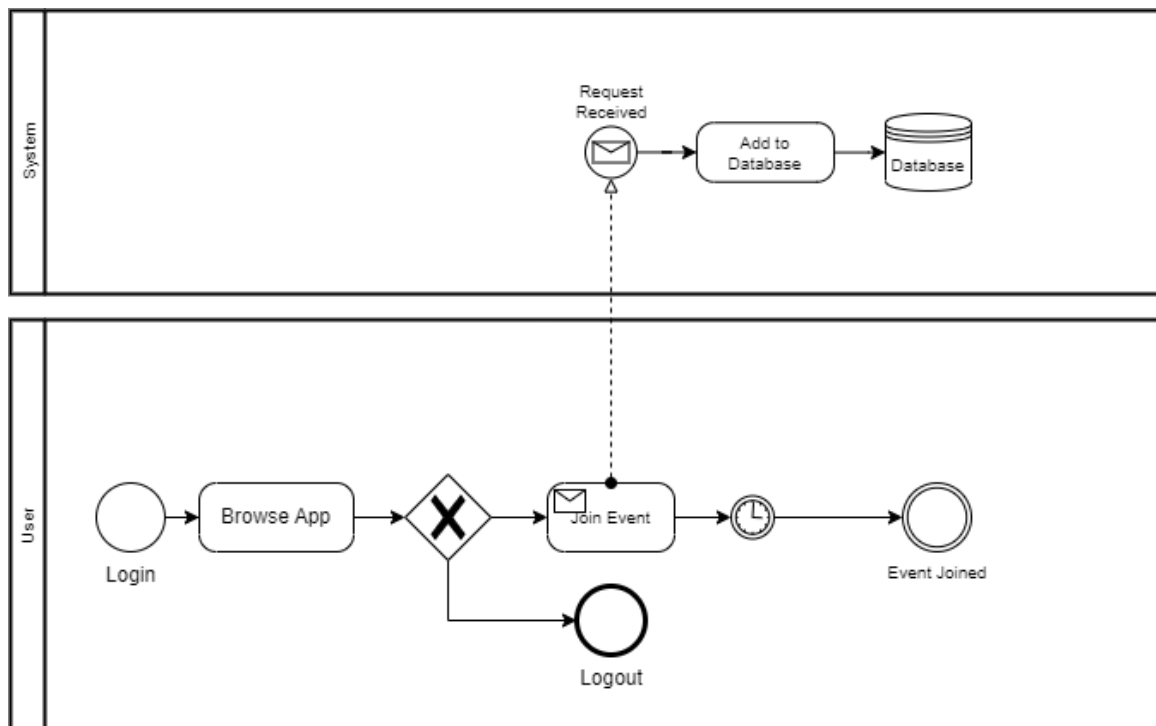

Figure 3.1: Join Event BPMN Model

3.2 Requirement Collection and Analysis

We talked to the DIU NLP Lab for the requirement collection and noted how they wanted the app to be. We asked several questions about how the design should look and what features are needed for the platform. Finally, we categorized the requirements according to the functionality into functional and non-functional requirements.

3.2.1 Functional requirements

Functional requirements describe functions that a system or component have be able to perform. It describes what the system must do. For the DIU NLP Lab web app, these are the functional requirements:

- User registration and login: Users should be able to create an account and log in to the web application using google account.
- Event calendar: The web application should include a calendar of upcoming events and workshops related to NLP, including details about the event's location, date, and time.
- Team information: The web application must include the team behind the NLP lab and their portfolios.
- Research paper listings: The web application should feature current and past research projects conducted at the DIU NLP Lab, with information about each project's goals, team members, and progress.
- News and updates: The web application should provide a section for posting and viewing news about the DIU NLP Lab, such as new research publications or funding opportunities.
- Resource Library: The web application should have resources for NLP researchers, including papers, datasets, and code.
- Contact information: The web application should include contact information for the DIU NLP Lab, such as the lab's address, email, and phone number.
- Responsive design: The web application should be optimized for viewing on various devices, including desktop computers, tablets, and smartphones.

3.2.2 Non-functional requirements

Non-functional requirements describe criteria a system or component have to satisfy that do not relate to a specific work or behavior. Instead, they describe how the system should behave and the quality of the service that the system should provide. These are the non-functional requirements for DIU NLP Lab's web app:

- Scalability: The web app should be able to handle an increasing number of users and data without significant performance degradation.

- **Security:** The web app should have measures to prevent unauthorized access to sensitive data and protect against cyber threats like hacking and data leakage.
- **Usability:** The web application should be easy to navigate and use, with a clear and intuitive user interface.
- **Compatibility:** The web app should be compatible with various web browsers and devices, including desktop, laptops, tablets, and mobile devices.
- **Accessibility:** The web application should be accessible to users with disabilities, including visual, auditory, and motor impairments.
- **Localization:** The web application should be able to support multiple languages and regions.
- **Performance:** The web application should have fast loading times and responsive interactions, with minimal delays or errors.
- **Maintainability:** The web app should be easy to maintain and update, with clear documentation and a well-organized codebase.
- **Extensibility:** The web app should be designed to add new features and functionality in the future easily.
- **Availability:** The web application should have high uptime and be available to users at all times, with failover mechanisms in place to prevent downtime in the event of technical issues.

3.2.3 Hardware Requirements

As we are developing a web application, some hardware will be needed to run the app. Hardware requirements for software refer to the minimum and recommended hardware specifications that a computer or device must meet to run a particular software effectively. These requirements may include processor type and speed, amount of RAM, hard drive space, and other hardware components. It is essential to ensure that a computer or device meets the software's hardware requirements before installing or using it, as insufficient hardware may result in poor performance or compatibility issues. Table 3.1 & 3.2 states the minimum and recommended hardware requirement for this project.

Table 3.1: Minimum hardware requirement for DIU NLP Lab web app

Hardware Name	Minimum Requirement
Processor	Intel Celeron or newer
Memory	2GB or more
Storage	1GB or more

Table 3.2: Recommended hardware requirement for DIU NLP Lab web app

Hardware Name	Recommended Requirement
Processor	Intel Core i5 or newer
Memory	8GB or more
Storage	5GB or more

3.2.4 Software Requirements

As we previously mentioned, it is a MERN stack-based responsive web application. MERN is a popular web application stack based on MongoDB, Express.js, React.js, and Node.js.

Table 3.3: The software requirements for the application.

Software Name	Version
Operating System	Windows 7 or higher, Ubuntu 16 or higher, macOS X
Node.js	18.12
NPM	8.19.2

Table 3.4: Frontend package dependencies

Package Name	Version
react, react-dom	18.2
react-day-picker	8.3.7

react-query	3.39.2
react-router-dom	6.4.5
date-fns	2.29.3
tailwindcss	3.2.4
daisyui	2.42.1
firebase	9.15.0
react-firebase-hooks	5.1.1
react-toastify	9.1.1

Table 3.5 Backend package dependencies

Package Name	Version
cors	2.8.5
dotenv	16.0.3
express	4.18.2
jsonwebtoken	8.5.1
Mongodb	4.12.1
axios	1.2.2
cheerio	1.0.0-rc.12

3.3 Use Case Modeling and Description

A use case diagram is a type of diagram used in software development to represent the actions a system should take in response to a request made by its users. It is a high-level visual representation of the interactions between external users and the system and is typically used to capture the system's functional requirements. Here is the use case diagram for DIU NLP Lab's web application

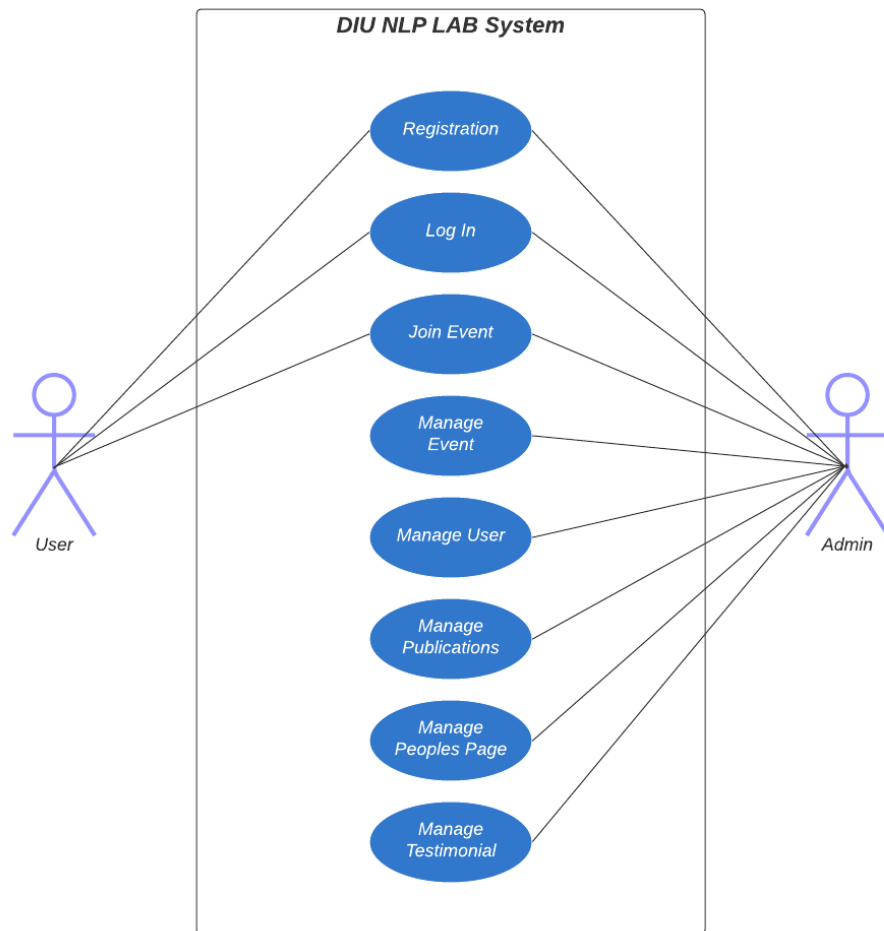

Figure 3.2: Use case diagram for DIU NLP Lab web app

Use Case Description:

Table 3.6: Use case description for DIU NLP Lab web app

<p>Use case: Register Actors: User, Admin Type: Primary Description: To access the all content in of the web application one must register Usage: To register information in database Extended By: None Extends: None</p>
<p>Use case: Login Actors: User, Admin Type: Primary</p>

Description: To access the all content in of the web application one must login to the system

Usage: To register information in database

Extended By: None

Extends: None

Use case: Manage Events

Actors: Admin

Type: Primary

Description: To Add, Delete events from events page

Usage: To Manage events in database

Extended By: None

Extends: None

Use case: Manage Users

Actors: Admin

Type: Primary

Description: To Add, Delete and Upgrade user from users page

Usage: To update user in database

Extended By: None

Extends: None

Use case: Manage Publications

Actors: Admin

Type: Primary

Description: To Add, Delete pages from research page

Usage: To update paper in database

Extended By: None

Extends: None

Use case: Manage Peoples

Actors: Admin

Type: Primary

Description: To Add, Delete peoples from Peoples page

Usage: To update people in database

Extended By: None

Extends: None

3.4 Logical Data Model

A logical data model represents a set of data and the relationships between data elements. It is a model that defines a database structure at a high level in terms of data types and the relationships between them. The logical data model is independent of the physical design of the database and is used to describe the structure of the database before it is implemented in a database management system. It is often used in the design of a database to help ensure that the data is organized in an efficient, easy-to-use, and maintainable way.

We developed the platform in the MERN stack, which uses MongoDB as a database. MongoDB is a NoSQL [12] database. It does not store data in a tabular form but in an unstructured way. So, there is no direct relation between them like SQL databases have.

Here is our database entity model:

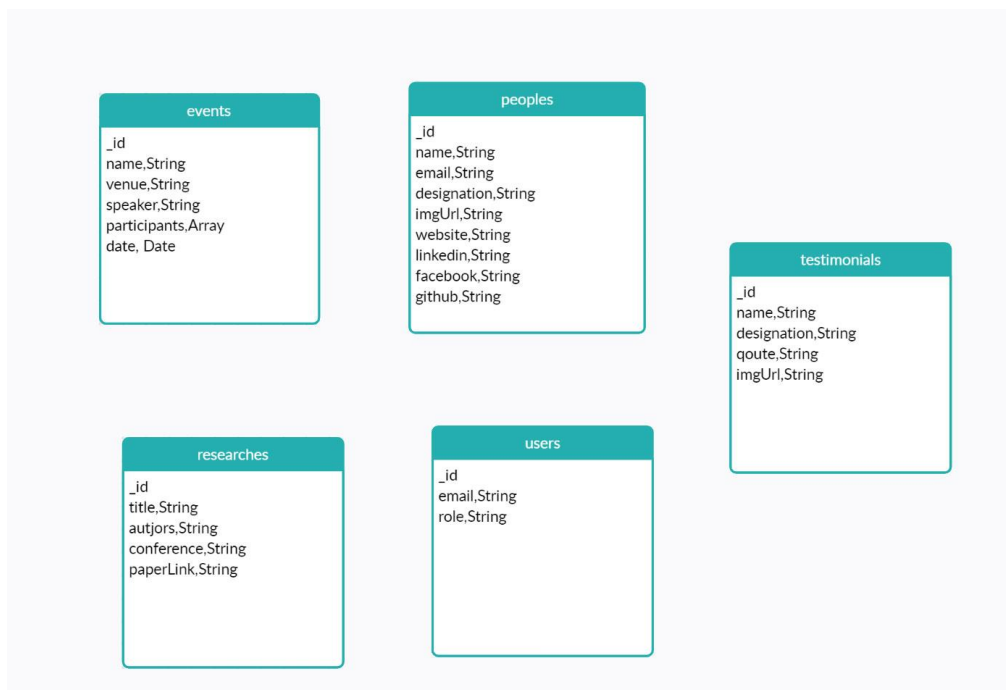

Figure 3.3: Data Schema for DIU NLP Lab web app

3.5 Design Requirement

Here are design requirements for the DIU NLP web application built with the MERN stack:

- **Responsive design:** The web application must be responsive and work seamlessly on devices with different screen sizes, including desktop, tablet, and mobile.
- **User authentication and authorization:** The web application should have a secure login system to allow users to create an account and access their data.
- **Data storage:** The web application should have a database (using MongoDB) to store user data, including any NLP-related data that the user generates or uploads.
- **Data processing:** The web application should have server-side logic (using Node.js and Express) to process user data and perform NLP tasks, such as text analysis or language translation.
- **User interface:** The web application should have a user-friendly interface (using React) for users to interact with the web application and view the results of NLP tasks.
- **Accessibility:** The web application must be accessible to all users. This includes using appropriate alt text for images and providing text alternatives for non-text content.
- **Fast loading times:** The web application must have fast loading times to ensure a positive user experience. This includes optimizing images and other assets and implementing caching techniques.
- **Search engine optimization (SEO) [13]:** The web application must be optimized for search engines to improve its visibility and ranking in search results. This includes using appropriate keywords, meta tags, and structured data.
- **Security:** The web application must implement appropriate security measures to protect against various cyber threats and data breaches. This includes using SSL/TLS for secure communication and implementing proper authentication and authorization practices.

CHAPTER 4

DESIGN SPECIFICATION

4.1 Front-end Design

We designed the web application with React.js. It is a powerful front-end JavaScript library that can build a single-page responsive web application. React.js is very fast compared to traditional frameworks or libraries. Each element of the page can be broken down as a component in React.js. Along with React.js, we used Tailwind CSS [14] framework and DaisyUI Kit [15] to style those react components.

React.js, a modern front-end application, does an increasing amount of labor-intensive work. Bugs are happening more often as a result of this increased complexity. Since users use the front end, we require an architecture which is dependable, scalable, and both. We currently favor a modular, domain-driven architecture.

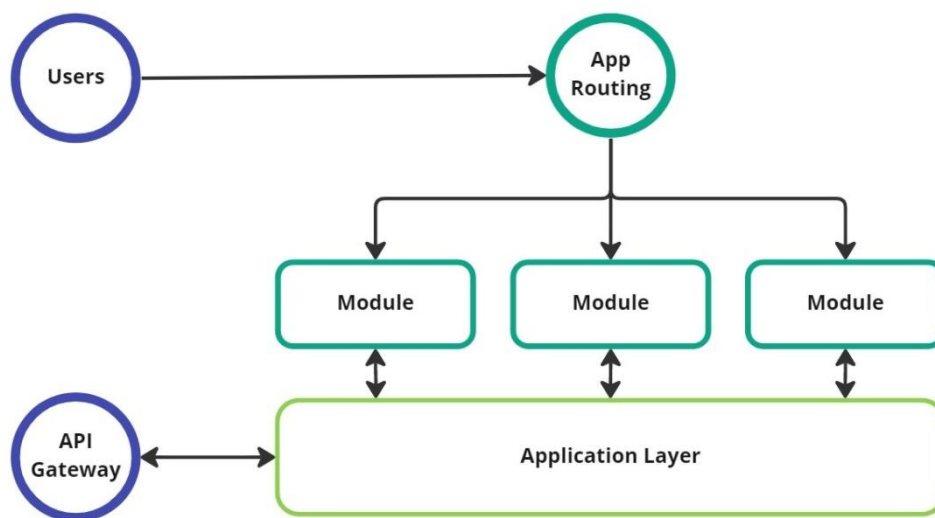

Figure 4.1: Front end architecture

When a user uses our application, he or she is redirected to the correct app module by the app routing. Every module is wholly contained. However, as users expect to use one whole application, not a few small ones, some similarities will exist. These similarities exist in several functions or components. We shared several features between modules. We put this design logic into the application layer. This means that each app module has the capability to interact with the application layer. A good

©Daffodil International University 17

example is a setup requiring us to connect to our backend, or API gateway, through the client-side API.

4.2 Back-end Design

For the NLP Lab's web application, we used the ever so popular MERN stack. MERN stack uses Node.js along with Express.js in the backend along with MongoDB as database. Node.js backend architecture refers to the design and structure of a Node.js application that is used as the server-side component of a web application. This architecture typically involves the following components:

API layer: This layer is responsible for handling requests from the client-side and interacting with the database to retrieve or update data. We implemented a REST API [16] using Express.js framework.

Database: This is the component that stores and retrieves data for the application. We used the NoSQL database called MongoDB in this project.

Models: These are the data structures that represent the lab web application's domain objects, such as people, events etc. They are responsible for interacting with the database and providing an interface for manipulating data.

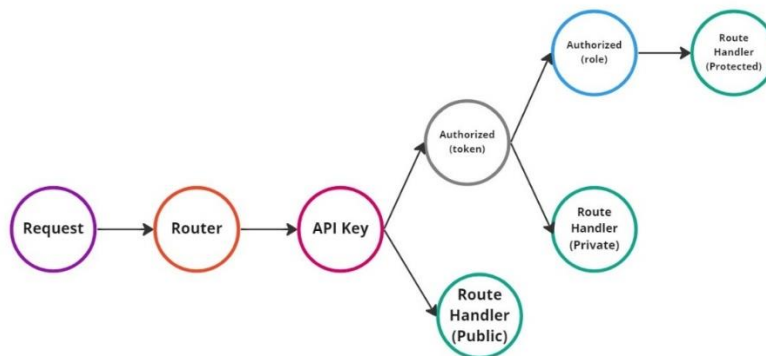

Figure 4.2: Back-end architecture

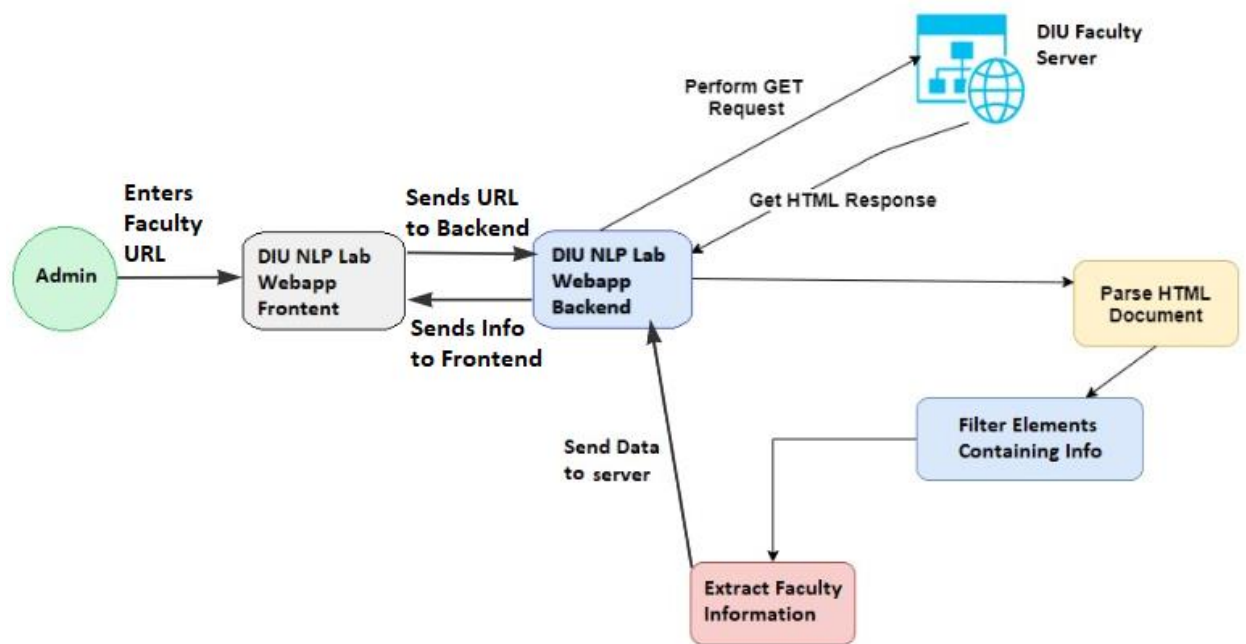

Figure 4.3: Web Scraper Architecture

To add new faculty in peoples page, the admin the faculty’s personal page URL from DIU faculty server. The front end validates the URL and sends it to the backend. The backend fetches the URL. Then it loads it into an easily phase able structure with cheerio.

The backend then targets the specific DOM elements that contains the information. If the data is valid, then it makes an information object. The backend then sends it to the information to the admin. Admin can check the information here. After that if the admin saves the data, it will be stored in the database.

4.3 Interaction Design and User Experience (UX)

We designed our user interface in Figma [17]. We made a prototype and showed it to some users. We made in total three versions and kept changing according to the feedback. This is the final result:

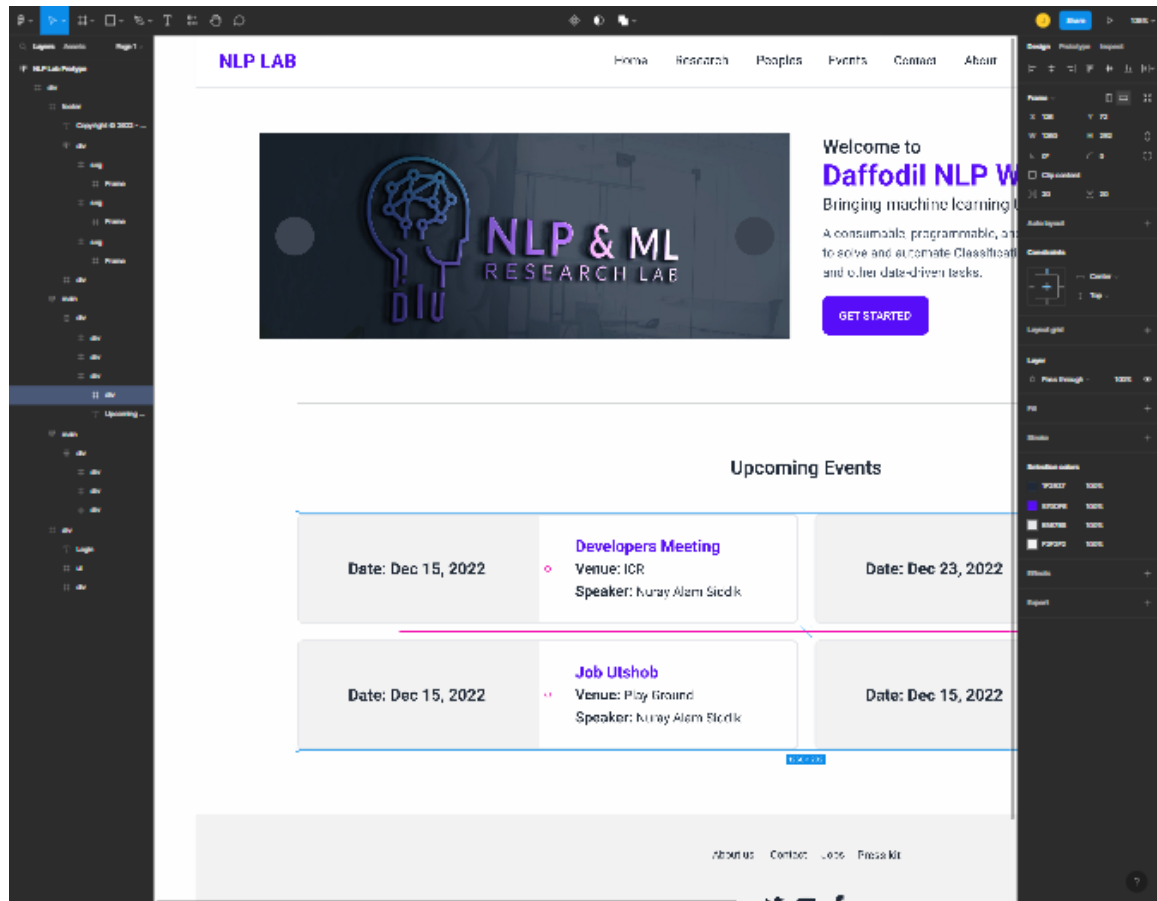

Figure 4.4: Homepage design in Figma

We tested the webapp in various screen sizes to make sure a seamless user experience. We kept the design tidy and made the platform easy to use. We tested the web app on various browsers to make sure it is compatible.

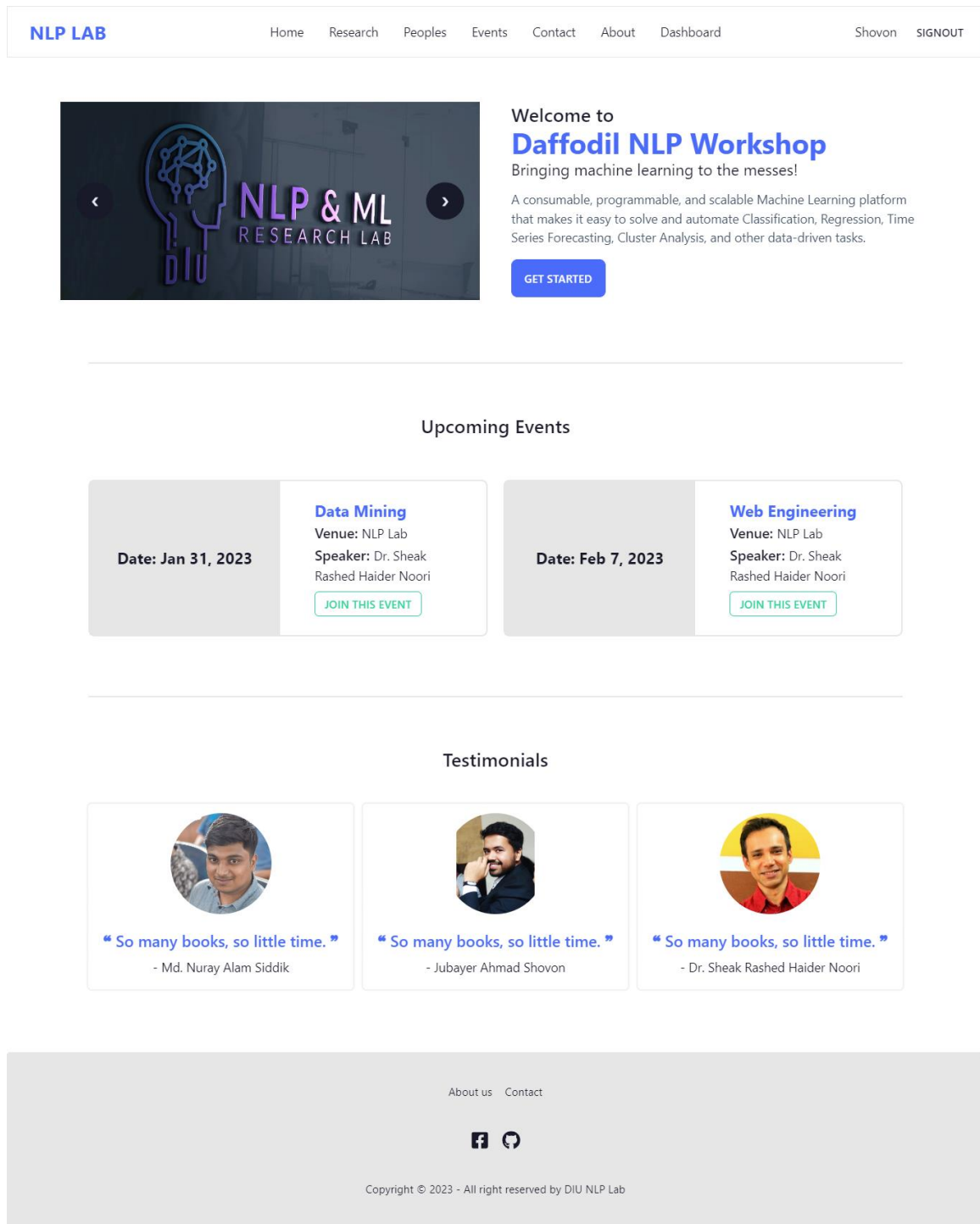

Figure 4.5: Homepage in desktop browser

Shown in figure 4.4, we tested the webapp in windows OS using chrome browser. The UI was responsive and was working properly.

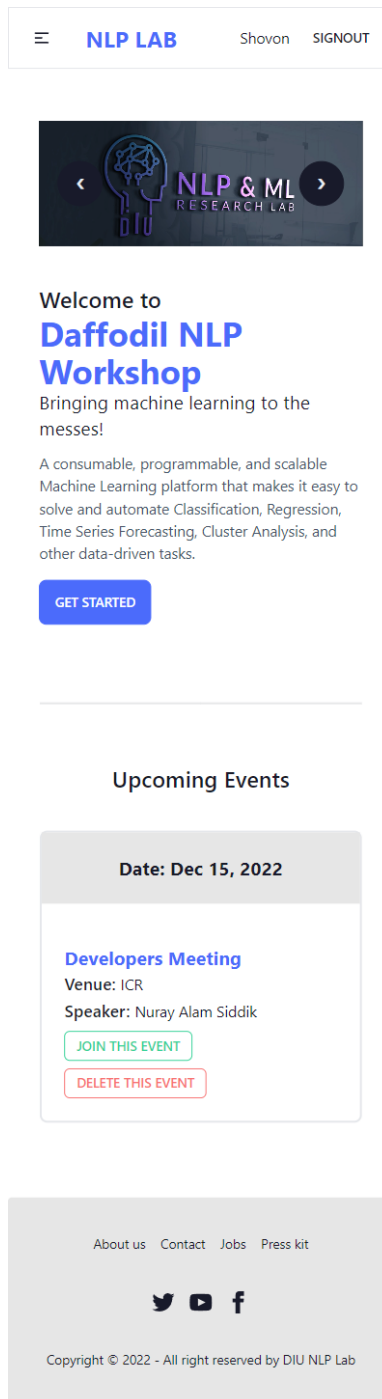

Figure 4.6: Home page on mobile browser

We used Samsung S20+ with chrome browser to test the mobile view of the platform.

4.4 Implementation Requirements

The platform is a web-based application. We developed it in the MERN stack. MERN stack uses a combination of MongoDB, Express.js, React.js, and Node.js. These technologies are built upon JavaScript [18]. So, JavaScript is the language we used to implement this project.

Along with JavaScript, we used HTML [19] and CSS [20] to design web pages. We used VSCode to code the project. GitHub was for the version control of the project. Next, we used Figma for prototyping and initial design. Finally, we used the tailwind CSS library to implement the front-end design.

CHAPTER 5

IMPLEMENTATION AND TESTING

5.1 Implementation of Database

To implement a database in a DIU NLP Lab Web application, which is built in MERN, we used MongoDB as the database system.

MongoDB is a NoSQL database, which is a type of database that does not use the traditional SQL tabular relational database structure. Instead, it stores data in JSON-like documents with optional schemas. This makes it a good choice for building modern web applications that need to store large amounts of data and handle high levels of concurrency.

To use DIU NLP Lab Web application, we first installed the MongoDB driver for Node.js and then connect to a MongoDB Atlas from the application. We can now use the MongoDB driver to create, read, update, and delete documents in the database.

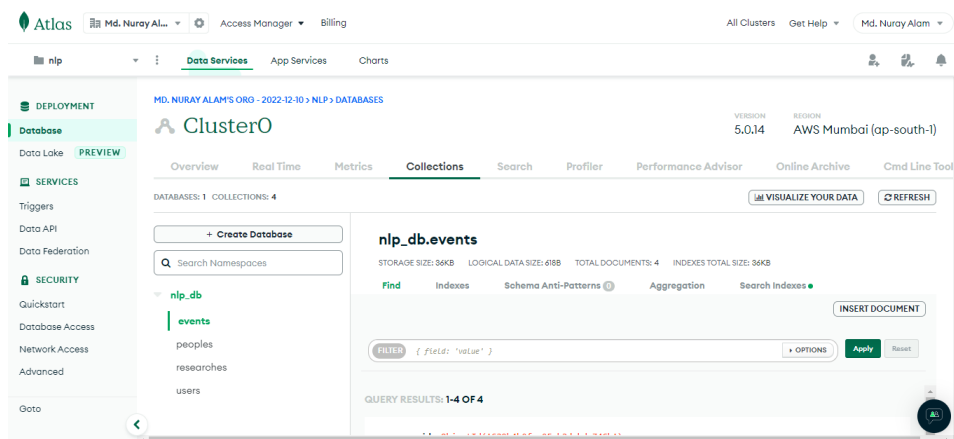

Figure 5.1: MongoDB Atlas Panel

5.2 Implementation of Front-end Design

Homepage: The user will see a carousel of images here as well as the upcoming events. The navbar will have an option to navigate through the pages. If the user is not logged in, there will be a Sign In button. Else it will show the user's name.

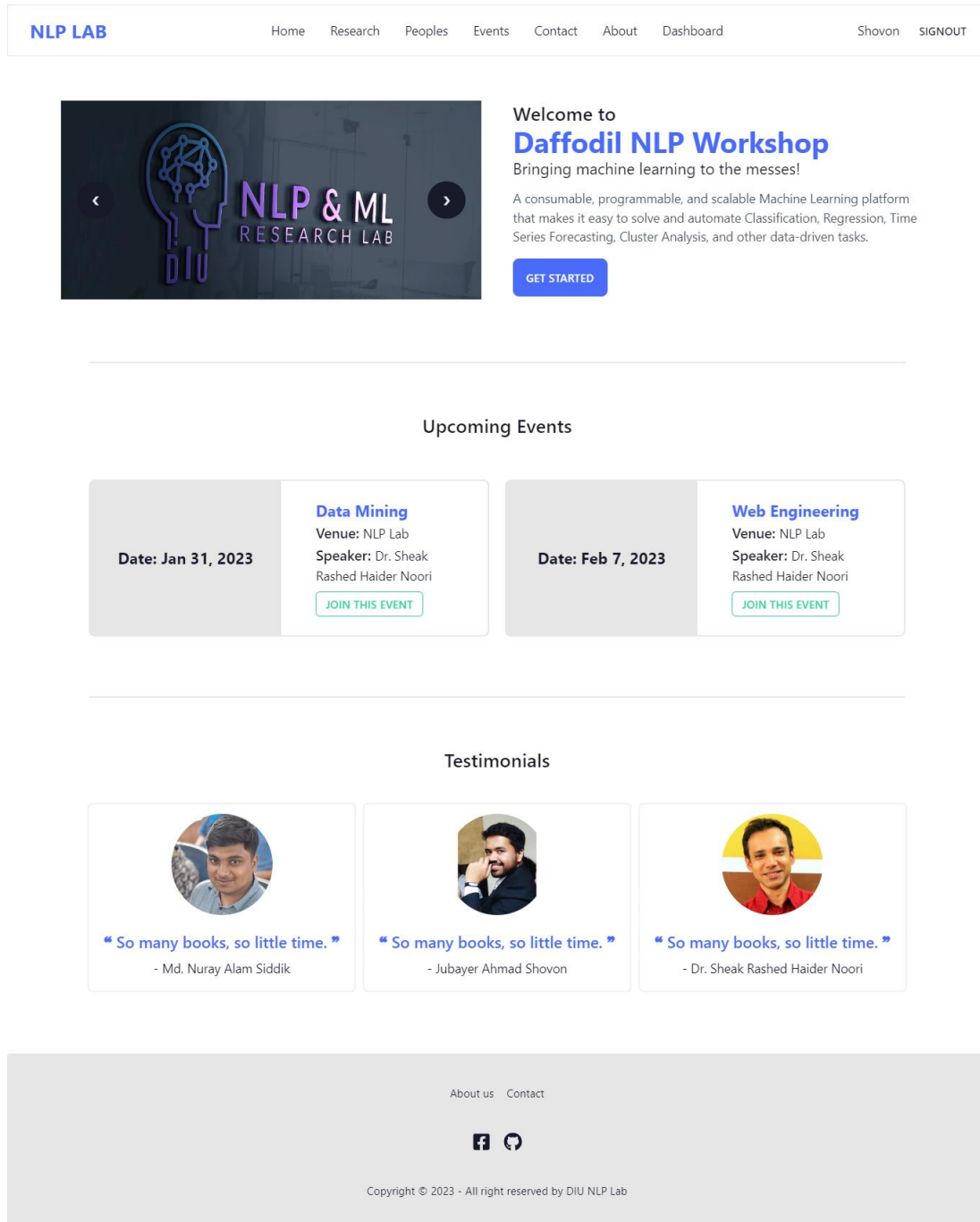

Figure 5.2: Home page

Research Page: List of research done by the NLP lab. Admin can add or delete papers from here.

The screenshot displays the 'All Researches' page of the NLP LAB. The page features a navigation bar with 'NLP LAB' on the left and 'Home', 'Research', 'Peoples', 'Events', 'Contact', 'About', 'Dashboard', 'Shovon', and 'SIGNOUT' on the right. The main content area lists seven research papers, each with the following information: author names, a title in quotes, the conference or journal name, and two buttons: 'PAPER LINK' (blue) and 'DELETE THIS PAPER' (red).

Author(s)	Title	Publication
Sheikh Abujar, Mahmudul Hasan	"A Comprehensive Text Analysis for Bengali TTS using Unicode"	5th IEEE International Conference on Informatics, Electronics and Vision (ICIEV), 13-14 May 2016, Dhaka, Bangladesh
Md Jamiur Rahman Rifat, Sheikh Abujar, Sheak Rashed Haider Noori, Syed Akhter Hossain	"Bengali Named Entity Recognition: A survey with deep learning benchmark"	10th International Conference on Computing, Communication and Networking Technologies (ICCCNT), IIT Kanpur, July 6-8, 2019
Md. Sanzidul Islam, Sadia Sultana Sharmin Mousumi, AKM Shahariar Azad Rabby, Sheikh Abujar, Syed Akhter Hossain	"A Potent Model to Recognize Bangla Sign Language Digits Using Convolutional Neural Network"	Procedia Computer Science (Elsevier), Volume 143, 2018, Pages 611-618
Sheikh Abujar, Mahmudul Hasan, M.S.I Shahin, Syed Akhter Hossain	"A heuristic approach of text summarization for Bengali documentation"	IEEE
Sheikh Abujar, Md. Shahidul, Abu Abed	"Assessing Sentence Similarity through Lexical Analysis for Text Summarization using Deep Learning"	Foundation of Computer Science
S. M. Mazharul Hoque Chowdhury, Priyanka Ghosh, Sheikh Abujar, Most. Arina Afrin, Syed Akhter Hossain	"Sentiment Analysis of Tweet Data: The Study of Sentimental State of Human from Tweet Text"	Springer Singapore
AKM Shahariar Azad Rabby, Sadeka Haque, Shammi Akhter Shahinooor, Sheikh Abujar, Syed Akhter Hossain	"A Universal Way to Collect and Process Handwritten Data for Any Language"	Elsevier BV

The footer contains 'About us' and 'Contact' links, social media icons for Facebook and GitHub, and a copyright notice: 'Copyright © 2023 - All right reserved by DIU NLP Lab'.

Figure 5.3: Research Page

Peoples Page: This page features the NLP lab team. Admin can add or delete people from here.

NLP LAB Home Research Peoples Events Contact About Dashboard Shovon SIGNOUT

All Peoples

All



Prof. Dr. Touhid Bhuiyan
Designation: Head, Department of Computer Science and Engineering, Daffodil International University
Email: headcse@daffodilvarsity.edu.bd
[DELETE THIS USER](#)



Dr. Sheak Rashed Haider Noori
Designation: Professor and Associate Head, Department of Computer Science and Engineering (CSE), Daffodil International University (DIU)
Email: drnoori@daffodilvarsity.edu.bd
[DELETE THIS USER](#)



Mr. Shah Md Tanvir Siddiquee
Designation: Assistant Professor, Department of Computer Science and Engineering, Faculty of Science and Information Technology
Email: tanvir.cse@diu.edu.bd
[DELETE THIS USER](#)



Mr. Abdus Sattar
Designation: Assistant Professor & Coordinator M.Sc. Department of Computer Science and Engineering, Faculty of Science and Information Technology
Email: abdu.s.cse@diu.edu.bd
[DELETE THIS USER](#)



Mr. Md. Sadekur Rahman
Designation: Assistant Professor, Department of Computer Science and Engineering, Faculty of Science and Information Technology
Email: sadekur.cse@daffodilvarsity.edu.bd
[DELETE THIS USER](#)



Mr. Narayan Ranjan Chakraborty
Designation: Associate Professor, Department of Computer Science and Engineering, Faculty of Science and Information Technology
Email: narayan@daffodilvarsity.edu.bd
[DELETE THIS USER](#)





Md. Nuray Alam Siddik
Designation: Lead Developer, Department of Computer Science and Engineering, Daffodil International University
Email: nuray.alam24@gmail.com
[DELETE THIS USER](#)



Jubayer Ahmad Shovon
Designation: Lead Developer, Department of Computer Science and Engineering, Daffodil International University
Email: jubayer15-12615@diu.edu.bd
[DELETE THIS USER](#)

About us Contact

Copyright © 2023 - All right reserved by DIU NLP Lab

Figure 5.4: Peoples Page

Events: Showcases the upcoming NLP Lab’s events. Users can join events. Admin can add or delete events from here.

NLP LAB Home Research Peoples Events Contact About Dashboard Shovon SIGNOUT



Upcoming Events

Date: Jan 31, 2023	Data Mining Venue: NLP Lab Speaker: Dr. Sheak Rashed Haider Noori JOIN THIS EVENT
Date: Feb 7, 2023	Web Engineering Venue: NLP Lab Speaker: Dr. Sheak Rashed Haider Noori JOIN THIS EVENT

Past Events

Date: Jan 7, 2023	Data Science Venue: ICR Speaker: Dr. Sheak Rashed Haider Noori
Date: Jan 10, 2023	Future of Web Development Venue: ICR Speaker: Dr. Sheak Rashed Haider Noori
Date: Jan 20, 2023	Event 1 Venue: NLP Lab Speaker: NLP Lab
Date: Jan 20, 2023	Event 2 Venue: NLP Lab Speaker: NLP Lab
Date: Jan 1, 2023	Researcher Meetup Venue: NLP Lab Speaker: Dr. Sheak Rashed Haider Noori

About us Contact

Copyright © 2023 - All right reserved by DIU NLP Lab

Figure 5.5: Events Page

Admin Dashboard: Admin can add people, events, papers, events and remove users or make a new admin from here.

NO.	NAME	DATE	TOTAL PARTICIPANTS	ACTION 1
1	Data Science	Jan 7, 2023	1	DELETE EVENT
2	Future of Web Development	Jan 10, 2023	1	DELETE EVENT
3	Event 1	Jan 20, 2023	0	DELETE EVENT
4	Event 2	Jan 20, 2023	0	DELETE EVENT
5	Data Mining	Jan 31, 2023	0	DELETE EVENT
6	Web Engineering	Feb 7, 2023	0	DELETE EVENT

Figure 5.6: Admin Dashboard

Login & Sign-Up page: This is the page where the user will login or signup using google account or email.

Figure 5.7: Login and Sign-Up Page

Contact Page & About page: Contact page holds the contact information for DIU NLP Lab. The page shows about the DIU NLP Labs.

5.3 Testing Implementation

Testing's main objective is to find problems with the online application. We can find a fix for any issues or faults that arise during testing, making it possible for people to use our system without interruption. The testing procedure is described in the section below. We manually input data and noted the outcome of the results. We first let some users use the platform as a beta test to see if they found any issues. We tasted we performance of the platform with GTmetrix [21].

5.4 Test Results and Reports

These are the results of various test done in the platform.

Table 5.1: Taste Case Results

Test Case	Test Input	Expected Outcome	Actual Outcome	Pass/Fail
User Registration	Proper username, email, password	Register	Register	Passed
User Login	Correct username, password	Login to the platform	Logged in to the platform	Passed
User Login	Wrong username, password	Error message should appear	Error message was shown	Passed
Joint Event	Go to event and click "Join This Event"	Should appear under "My Events"	Appeared under "My Events"	Passed
Add Event (Admin)	Event name, venue, speaker	New event should be created	New event was created	Passed
Delete Event (Admin)	Go to event and click "Delete This Event"	Event should be deleted and will not appear	Event was deleted	Passed

Delete User (Admin)	Go to Dashboard - > All Users and Click “Delete User”	User Should be deleted from the platform	User was Deleted	Passed
Add Research (Admin)	Enter author or paper title. Click Add paper from the search results	New paper entry should be created	Paper entry was created	Passed
Delete Research (Admin)	Go to Research and Click “Delete this paper”	Paper should be deleted from the app	Paper was deleted from the app	Passed
Add People – Student (Admin)	Proper full name, email, desi nation, profile image, portfolio link, LinkedIn, GitHub & Facebook profile link	New people (student) should appear in the people’s page	New people entry was created	Passed
Add People – Faculty (Admin)	Enter faculty webpage link, slick scrap. Click Submit.	New people (faculty) should appear in the people’s page	Faculty was added to the people’s page	Passed
Add Testimonials (Admin)	Name, testimonial, email address and profile picture	Testimonial should be added on the database	New testimonial was added to the database and showing on homepage	Passed

Test Report: Here 8 test case is shown. All of tastes were passed by the web application.

Table 5.2: Test Report

Tests Done	12
Tests Passed	12
Accuracy	100%

Here is the performance result from GTmetrix

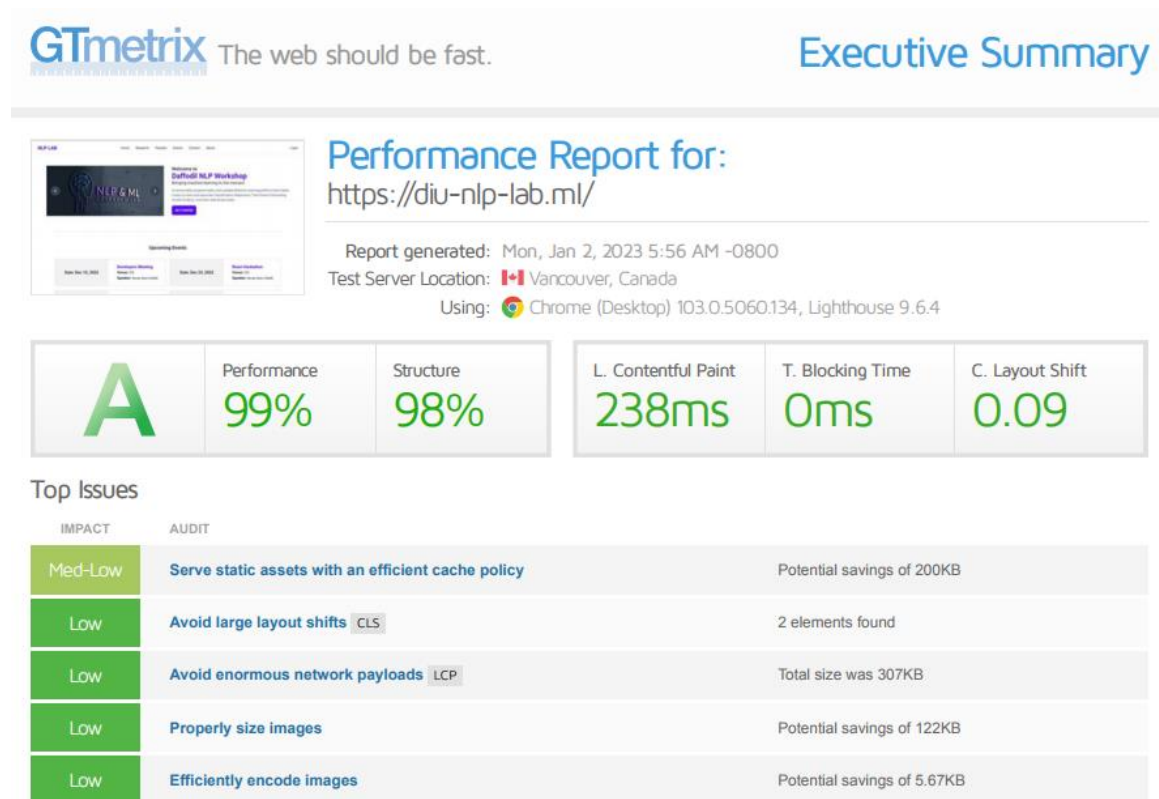

Figure 5.8: GTmetrix report

CHAPTER 6

IMPACT ON SOCIETY, ENVIRONMENT AND SUSTAINABILITY

6.1 Impact on Society

NLP (Natural Language Processing) is a field of computer science, AI (artificial intelligence), and linguistics focused with the interactions between computers and human (natural) languages. NLP plays a crucial role in many areas of society, including language translation, information retrieval, and text analysis.

A web application dedicated to DIU NLP Lab research could have several impacts on society. For example:

- It could disseminate information about the latest DIU NLP Lab developments in NLP, benefiting researchers, students, and professionals working in the field.
- It could provide a platform for NLP researchers to share their work and collaborate with others, leading to new insights and advancements in the field.
- It could help educate the public about NLP and its applications, increasing awareness and understanding of the field and its potential impact on society.
- It could provide a resource for businesses and organizations looking to apply NLP technology to solve problems or improve operations.
- Overall, the DIU NLP Lab web application will contribute to the advancement of the field and its impact on society by fostering collaboration, education, and the application of NLP technology.

6.2 Impact on Environment

Our system does not have any environmental impact. We do not need to employ any additional hardware to build our system because it is web-based. We use web servers which are already available for our project. Our solution is, therefore, entirely secure for the environment.

6.3 Sustainability Plan

Sustainability plan for the DIU NLP Lab is made considering few key factors. They are cost of implementation, cost of maintenance, impact on environment. We already stated that the app does not have a negative impact on the environment. The production release will be dockerized [22] so it will be secure and will be easy to do maintenance. Overall, it will be cost effective and easier to maintain.

CHAPTER 7

CONCLUSION AND FUTURE SCOPE

7.1 Discussion and Conclusion

In conclusion, the DIU NLP app is a valuable tool that is designed to improve collaboration and organization within the NLP lab at DIU. Its user-friendly interface allows regular users and administrators to interact easily with the app and access important information. In addition, the app's features, such as the ability to add and view events and research projects, and the admin panel that allows the administrator to manage the lab's activities, will help to streamline communication and increase the efficiency and productivity of the NLP lab.

In the future, there are several potential areas for improvement and expansion of the DIU NLP app. By continuing to evolve and improve the DIU NLP app, it has the potential to become an even more valuable resource for the NLP lab and the university as a whole.

7.2 Scope for Further Developments

This web application is developed from scratch, so it can add new features as we follow the agile model, so whenever we have an idea to add a new feature, we have the full opportunity to add that. That would be more useful if we added many useful features that can make more interaction in the app. In the future, we want to provide NLP-based services, such as language translation or text analysis, to the users. We also want to add a feature to visualizing and analyzing NLP data, such as word clouds or sentiment analysis. We also want to add a chat system to the platform so that researchers and users can communicate with each other.

REFERENCES

- [1] DIU NLP Lab Web Application, available at << <https://diu-nlp-lab.ml/>>>, last accessed on 03-01-2022 at 12:00 PM.
- [2] MERN Stack Explained, available at << <https://www.mongodb.com/mern-stack/>>>, last accessed on 02-01-2022 at 2:00 PM.
- [3] MongoDB, available at <<<https://www.mongodb.com/>>>, last accessed on 02-01-2022 at 11:00 PM.
- [4] Express - Node.js web application framework, available at << <https://expressjs.com/>>>, last accessed on 01-01-2022 at 11:00 PM.
- [5] React – A JavaScript library for building user interfaces, available at <<<https://reactjs.org/>>>, last accessed on 01-01-2022 at 3:00 PM.
- [6] Node.js, available at <<<https://nodejs.org/>>>, last accessed on 01-01-2022 at 11:00 PM.
- [7] Natural language processing - Wikipedia, available at <<https://en.wikipedia.org/wiki/Natural_language_processing>>, last accessed on 01-01-2022 at 12:05 PM.
- [8] Visual Studio Code - Code Editing. Redefined, available at <<<https://code.visualstudio.com/>>>, last accessed on 01-01-2022 at 04:00 PM.
- [9] Natural Language Processing Lab, SUST, available at <<<https://nlp.sust.edu/>>>, last accessed on 01-01-2022 at 04:30 PM.
- [10] BUET CSE NLP Group, available at <<<https://csebuetnlp.github.io/>>>, last accessed on 01-01-2022 at 04:30 PM.
- [11] Stanford NLP Group - Stanford University, available at << <https://nlp.stanford.edu/> >>, last accessed on 01-01-2022 at 04:33 PM.
- [12] NoSQL - Wikipedia, available at << <https://en.wikipedia.org/wiki/NoSQL>>>, last accessed on 01-01-2022 at 5:00 PM.
- [13] What Is SEO - Search Engine Optimization, available at <<<https://searchengineland.com/guide/what-is-seo> >>, last accessed on 01-01-2022 at 5:30 PM.
- [14] Tailwind CSS - Rapidly build modern websites, available at <<<https://tailwindcss.com/>>>, last accessed on 01-01-2022 at 10:07 PM.
- [15] daisyUI — Tailwind CSS Components, available at <<<https://daisyui.com/>>>, last accessed on 01-01-2022 at 1:00 PM.
- [16] What is a REST API, available at <<<https://www.redhat.com/en/topics/api/what-is-a-rest-api>>>, last accessed on 01-01-2022 at 1:10 PM.

- [17] Figma: the collaborative interface design tool, available at << <https://www.figma.com/>>>, last accessed on 01-01-2022 at 1:05 PM.
- [18] JavaScript Tutorial, available at << <https://www.w3schools.com/js/>>>, last accessed on 01-01-2022 at 12:05 PM.
- [19] HTML Tutorial, available at <<<https://www.w3schools.com/html/>>>, last accessed on 01-01-2022 at 11:07 PM.
- [20] CSS Tutorial, available at <<<https://www.w3schools.com/css/>>>, last accessed on 01-01-2022 at 10:50 PM.
- [21] GTmetrix | Website Performance Testing and Monitoring, available at <<<https://gtmetrix.com/>>>, last accessed on 01-01-2022 at 12:50 PM.
- [22] Dockerizing | Developer Experience Knowledge Base, available at <<<https://developerexperience.io/articles/dockerizing>>>, last accessed on 01-01-2022 at 11:00 PM.

For_Checking_Plagiarism_-_Enigma.docx

ORIGINALITY REPORT

10%	8%	1%	5%
SIMILARITY INDEX	INTERNET SOURCES	PUBLICATIONS	STUDENT PAPERS

PRIMARY SOURCES

1	dspace.daffodilvarsity.edu.bd:8080 Internet Source	3%
2	www.finaps.nl Internet Source	2%
3	Submitted to University of Derby Student Paper	1%
4	Submitted to Daffodil International University Student Paper	1%
5	Submitted to Wawasan Open University Student Paper	<1%
6	biomedical-engineering- online.biomedcentral.com Internet Source	<1%
7	Submitted to HELP UNIVERSITY Student Paper	<1%
8	Submitted to Swinburne University of Technology Student Paper	<1%

9	Md. Mehedi Hasan, Sadia Tamim Dip, T. M. Kamruzzaman, Sonia Akter, Imrus Salehin. "Movie Subtitle Document Classification Using Unsupervised Machine Learning Approach", 2021 IEEE 6th International Conference on Computing, Communication and Automation (ICCCA), 2021 Publication	<1 %
10	Submitted to Zambia Centre for Accountancy Studies Student Paper	<1 %
11	inspire.redlands.edu Internet Source	<1 %
12	www.kyinbridges.com Internet Source	<1 %
13	Submitted to University of Wolverhampton Student Paper	<1 %
14	allergen-nce.ca Internet Source	<1 %
15	essay.utwente.nl Internet Source	<1 %
16	riunet.upv.es Internet Source	<1 %
17	Submitted to Montclair State University Student Paper	<1 %

Exclude quotes On

Exclude bibliography On

Exclude matches < 10 words