

**IOT BASED HOME AUTOMATION SYSTEM**

**BY**

**MD ABID KHAN  
ID: 121-15-1687**

This Report Presented in Partial Fulfillment of the Requirements for the  
Degree of Bachelor of Science in Computer Science and Engineering

Supervised By

**Mr. Narayan Ranjan Chakraborty**  
Associate Professor  
Department of CSE  
Daffodil International University



**DAFFODIL INTERNATIONAL UNIVERSITY**

**DHAKA, BANGLADESH**

**FEBRUARY 2023**

## APPROVAL

This Project/internship titled "**IOT BASED HOME AUTOMATION SYSTEM**", submitted by MD ABID KHAN, ID: 121-15-1687 to the Department of Computer Science and Engineering, Daffodil International University has been accepted as satisfactory for the partial fulfilment of the requirements for the degree of B.Sc. in Computer Science and Engineering and approved as to its style and contents. The presentation has been held on 04/02/2023.

### BOARD OF EXAMINERS

Chairman

---

**Dr. Touhid Bhuiyan**  
**Professor and Head**  
Department of Computer Science and Engineering  
Faculty of Science & Information Technology  
Daffodil International University

Internal Examiner

---

  
**Subhenur Latif**  
**Assistant Professor**  
Department of Computer Science and Engineering  
Faculty of Science & Information Technology  
Daffodil International University

Internal Examiner

---

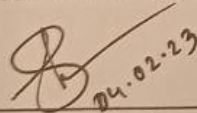
  
**Md. Sabab Zulfiker**  
**Senior Lecturer**  
Department of Computer Science and Engineering  
Faculty of Science & Information Technology  
Daffodil International University

External Examiner

---

  
**Dr. Md. Sazzadur Rahman**  
**Associate Professor**  
Institute of Information Technology  
Jahangirnagar University

## DECLARATION

I hereby declare that this project has been done by us under the supervision of **Mr. Narayan Ranjan Chakraborty, Associate Professor, Department of CSE** Daffodil International University. I also declare that neither this project nor any part of this project has been submitted elsewhere for award of any degree or diploma.

**Supervised by:**

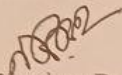

**Mr. Narayan Ranjan Chakraborty**  
Associate Professor  
Department of CSE  
Daffodil International University

**Submitted by:**



**Md Abid Khan**  
ID: -121-15-1687  
Department of CSE  
Daffodil International University

## ACKNOWLEDGEMENT

First I express my heartiest thanks and gratefulness to almighty God for His divine blessing makes me possible to complete the final year project/internship successfully.

I really grateful and wish my profound indebtedness to **Mr. Narayan Ranjan Chakraborty, Associate Professor**, Department of CSE Daffodil International University, Dhaka. Deep Knowledge & keen interest of my supervisor in the field of IoT and automation to carry out this project. His endless patience, scholarly guidance, continual encouragement, constant and energetic supervision, constructive criticism, valuable advice, reading many inferior drafts, and correcting them at all stages have made it possible to complete this project.

I would like to express my heartiest gratitude to family members, well-wishers, and the Head of the Department of CSE, for his kind help to finish my project and also to other faculty members and the staff of the CSE department of Daffodil International University.

I would like to thank my entire coursemate at Daffodil International University, who took part in this discussion while completing the coursework.

Finally, I must acknowledge with due respect the constant support and patients of our parents.

## **ABSTRACT**

The IoT-based Home Automation System is an innovative solution that enables homeowners to control and monitor various appliances from a single platform. It offers an easy-to-use and secure interface for users to manage and regulate their home environment remotely. The system's installation is straightforward, allowing users to connect to their home network in no time. The web interface is user-friendly, allowing the user to turn on/off lights, fans, or any other home appliance with a few clicks. The IoT-based Home Automation System comes with a scheduling feature that allows users to set specific times for appliances to turn on/off, providing convenience and flexibility. Users can control their home appliances even when they're away, ensuring a comfortable living environment. The system also protects user privacy by encrypting all data transmitted, ensuring that sensitive information remains confidential. With the history tracking feature, users can view a record of past events, enabling them to monitor trends and make changes to their home automation system as required. The IoT-based Home Automation System offers a convenient and secure way of controlling and monitoring home appliances, making users' lives more comfortable and hassle-free. The IoT-based Home Automation System is a smart and innovative solution for controlling and monitoring various appliances from a single platform. It offers an easy-to-use, convenient, and secure solution for users to manage their home environment, making their lives easier and more comfortable.

## TABLE OF CONTENTS

<b>CONTENTS</b>	<b>PAGE</b>
Approval Page	I
Declaration	II
Acknowledgement	III
Abstract	IV
List of Figures	VIII
<b>CHAPTER</b>	
<b>CHAPTER 1: INTRODUCTION</b>	<b>1-5</b>
1.1 Introduction	1
1.2 Motivation	1
1.3 Objectives	2
1.4 Expected Outcomes	3
1.5 Project Management and Finance	3
1.6 Report Layout	4
<b>CHAPTER 2: BACKGROUND</b>	<b>6-10</b>
2.1 Terminologies	6
2.2 Relevant Works	6
2.3 Comparative Analysis	7
2.4 Scope of the Problem	8
2.5 Challenges	9

<b>CHAPTER 3: REQUIREMENT SPECIFICATION</b>	<b>11-16</b>
3.1 Business Process Model	11
3.2 Requirement Collection and Analysis	12
3.3 Use Case Modeling and Description	12
3.4 Logical Data Model	15
3.5 Design Requirement	15
<b>CHAPTER 4: DESIGN SPECIFICATION</b>	<b>17-24</b>
4.1 Front-end Design	17
4.2 Back-end Design	18
4.3 Interaction Design and User Experience (UX)	19
4.4 Implementation Requirements	20
4.4.1 NodeMCU ESP8266	20
4.4.2 Relay Module	21
4.4.3 MQTT Broker	22
4.4.4 Node JS Development Environment	23
4.4.5 Switch	23
4.4.6 Power Source	24
<b>CHAPTER 4: DESIGN SPECIFICATION</b>	<b>25-31</b>
5.1 Implementation of Database	25
5.2 Implementation of Front-end Design	27
5.3 Testing Implementation	30

5.4 Test Results and Reports	30
<b>CHAPTER 6: IMPACT ON SOCIETY, ENVIRONMENT AND SUSTAINABILITY</b>	<b>32-35</b>
6.1 Impact on Society	32
6.2 Impact on Environment	33
6.3 Ethical Aspects	34
6.4 Sustainability Plan	35
<b>CHAPTER 7: CONCLUSION AND FUTURE SCOPE</b>	<b>36-37</b>
7.1 Discussion and Conclusion	36
7.2 Scope for Further Developments	37
<b>APPENDIX</b>	<b>38-39</b>
<b>REFERENCES</b>	<b>40</b>



## LIST OF FIGURES

FIGURE	PAGE NO
3.1 High-level architecture of the system	11
3.2 Circuit diagram of IoT device	13
3.3 Sequence diagram of smarthome	14
4.1 NodeMCU ESP8266	21
4.2 Relay module	22
4.3 Touch switch	24
5.1 DB schema of the application	26
5.2 Device with switch	28
5.3 Device with app	28
5.4 Device action page	29
8.1 NodeMCU logs communicating with the broker	37
8.2 User management page	37
8.3 Role management page	38
8.4 Permission management page	38

# CHAPTER 1

## INTRODUCTION

### 1.1 Introduction

The demand for home automation solutions is on the rise as homeowners seek to make their homes more convenient, efficient, and secure. The IoT based home automation system project is aimed at fulfilling these needs by providing a user-friendly home automation system that allows for real-time monitoring and control of various connected devices within the home. With the ability to monitor and control these devices, homeowners will have greater control over their homes and be able to improve their overall quality of life.

The project's main objective is to offer a cutting-edge home automation solution that meets the needs and expectations of homeowners. The system is designed with a focus on performance, reliability, and security, ensuring that it provides high-quality monitoring and control capabilities. Its user-friendly interface and robust security measures give homeowners confidence and peace of mind while managing their homes. Additionally, the system is designed to be scalable and cost-effective, making it a practical solution for homeowners. The IoT based home automation system project represents a significant advancement in home automation technology, offering homeowners a solution that meets their needs and exceeds their expectations. With the increasing demand for smart home solutions, this project has the potential to make a significant impact on the home automation industry.

### 1.2 Motivation

The growth of the home automation industry has been driven by the increasing demand for smart home solutions that offer convenience, efficiency, and security. The IoT based home automation system project aims to address these needs by delivering a high-quality home automation solution that leverages advanced technology to offer real-time monitoring and control capabilities for connected devices in the home. With the ability to monitor and control these devices from anywhere and at any time, homeowners can enjoy greater control and flexibility over their homes, improving their overall quality of life.

In addition to providing convenience and control, the IoT based home automation system project is also motivated by the need to improve performance, reliability, and security in home automation. With the rise of connected devices in the home, the security of these devices and the data they generate is a growing concern. The IoT based home automation system project is designed with security as a top priority, incorporating robust security measures to ensure that homeowners' data and devices are protected. The system's reliability is also a key factor, as it is designed to be scalable and easy to maintain, ensuring that homeowners can rely on it for years to come. The focus on performance, reliability, and security makes the IoT based home automation system project a valuable solution for homeowners seeking a high-quality, secure, and reliable home automation solution.

### **1.3 Objectives**

The first objective of the IoT based home automation system project is to provide a user-friendly home automation solution that allows for real-time monitoring and control of connected devices in the home. The system should be easy to use, with a clear and intuitive interface that makes it simple for homeowners to manage their homes. The real-time monitoring and control capabilities of the system should enable homeowners to monitor and control their homes from anywhere and at any time, providing greater control and flexibility over their homes.

The second objective of the IoT based home automation system project is to improve performance, reliability, and security in home automation. The system should be designed to provide high-quality monitoring and control capabilities, with a focus on performance and reliability to ensure that it is scalable and easy to maintain over time. Security is also a key factor, with robust security measures in place to protect homeowners' data and devices from unauthorized access. The system should be designed to be cost-effective, making it a practical solution for homeowners. Additionally, the system should be designed to be scalable, allowing for future growth and expansion as needed. These

objectives represent the key goals of the IoT based home automation system project, and serve as the foundation for its design and implementation.

## **1.4 Expected Outcome**

The expected outcomes of the IoT based home automation system project are aimed at delivering increased convenience, improved performance and reliability, enhanced security, cost-effectiveness, and scalability to homeowners. These outcomes will enable homeowners to enjoy a smarter, more convenient, and more secure home environment, while also providing a cost-effective and scalable solution for future growth and expansion.

Here are a couple of points that further detail the expected outcomes:

- **Increased Convenience:** The home automation system will allow homeowners to monitor and control their homes from anywhere and at any time, providing greater control and flexibility over their homes.
- **Improved Performance:** The system will be designed to provide high-quality monitoring and control capabilities, with a focus on performance and reliability to ensure that it is scalable and easy to maintain over time.
- **Enhanced Security:** Robust security measures will be in place to protect homeowners' data and devices from unauthorized access.
- **Cost-effectiveness:** The system will be designed to be cost-effective, making it a practical solution for homeowners.
- **Scalability:** The system will be designed to be scalable, allowing for future growth and expansion as needed.

## **1.5 Project Management and Finance**

Project management is a crucial aspect of any project, and the IoT based home automation project is no exception. Effective project management helps to ensure that the project is delivered on time, within budget, and to the required quality standards.

In order to manage the project effectively, it is important to have a clear understanding of the project scope, budget, and timeline. A project management plan should be developed, which outlines the key activities, milestones, and responsibilities for each team member.

One of the key aspects of project management is effective financial management. The budget for the project must be carefully planned and monitored to ensure that it stays within the approved limits. This includes considering the costs of materials, equipment, and labor as well as any contingencies that may arise during the project.

It is also important to have a robust risk management plan in place, which identifies potential risks and outlines strategies for mitigating those risks. This includes considering both technical risks, such as those associated with the development of the IoT devices, as well as project risks, such as changes in project scope or delays in delivery.

In addition, it is important to have effective communication processes in place to ensure that all stakeholders are kept informed about project progress and any issues that arise. This includes regular project status reports, which should be produced and distributed to all stakeholders on a regular basis.

Overall, effective project management and financial management are essential for the successful delivery of the IoT based home automation project. They help to ensure that the project is completed on time, within budget, and to the required quality standards, which in turn helps to deliver the desired outcomes and benefits for the end users.

## **1.5 Report Layout**

The report layout for the above project is organized in a comprehensive and logical manner, starting with the introduction of the project and its objectives in Chapter 1. In this chapter, the reader will find an overview of the motivation behind the project, as well as the expected outcomes. In addition, the chapter will also cover the Project Management and Finance, which will provide an insight into the financial aspect of the project and how it is being managed.

Chapter 2 focuses on the background of the project and provides the reader with a comprehensive understanding of the related works, comparative analysis, scope of the

problem and the challenges faced during the project. This chapter will also provide an overview of the terminologies used in the project and their significance. Chapter 3 deals with the requirement specification of the project. Here, the reader will find the details of the business process modeling, requirement collection and analysis, use case modeling and description, logical data model and design requirements. The chapter will provide an in-depth understanding of the project requirements and how they were analyzed. Chapter 4 covers the design specification of the project, including the front-end design, back-end design, interaction design and user experience (UX), and implementation requirements. This chapter will provide a clear picture of the design and implementation aspects of the project.

Chapter 5 is dedicated to the implementation and testing of the project. The reader will find details on the implementation of the database, front-end design, and testing implementation along with the results and reports. Chapter 6 focuses on the impact of the project on society, environment, and sustainability. The reader will find a detailed discussion on the impact on society, environment, ethical aspects, and sustainability plan. Finally, Chapter 7 provides the conclusion and future scope of the project. This chapter will provide an overview of the discussion and conclusion, along with the scope for further developments.

## **CHAPTER 2**

### **BACKGROUND**

#### **2.1 Terminologies**

Terminologies in the IoT project refer to the basic concepts and technologies involved in the project. The following are some of the key terms related to the project:

**Microcontroller:** A small computer on a single integrated circuit that can be programmed to control various electronic devices.

**NodeMCU ESP8266 Wi-Fi Microcontroller:** An open-source development platform that provides a complete Wi-Fi solution for IoT devices.

**Relay Module:** An electronic device that is used to switch electrical circuits remotely.

**MQTT Broker:** A server that facilitates the communication between IoT devices and applications.

**Node JS Development Environment:** A runtime environment for executing JavaScript code on the server-side.

**Arduino IDE:** An open-source software used to develop code for microcontroller devices.

**Switch:** An electrical component used to turn on/off electrical circuits.

**Power Source:** A device that provides electrical energy to power the electronic components in the project.

In conclusion, these are the core terminologies used in the IoT project that enables the control of home appliances using a web application.

#### **2.2 Related Works**

The IoT based home automation system project builds upon the work of many researchers and developers who have explored various aspects of home automation and IoT technology. Here are some of the key related works in this area:

- **Home Automation Systems:** A number of home automation systems have been developed over the years, with varying levels of complexity and functionality.

These systems typically use a combination of hardware and software components  
©Daffodil International University

to provide control and monitoring capabilities, often using wireless protocols such as Zigbee or Z-Wave.

- IoT-based Home Automation: In recent years, the use of IoT technology in home automation systems has become increasingly common. This allows homeowners to monitor and control their homes from anywhere using a smartphone or other mobile device, and enables the integration of a wide range of devices and sensors.
- MQTT Protocol: MQTT (Message Queue Telemetry Transport) is a widely used communication protocol for IoT devices and systems. MQTT provides a lightweight and efficient way to transmit data between devices, making it well-suited for use in home automation systems.

Taken together, these related works provide a foundation for the development of an IoT based home automation system that leverages the best features of these technologies to deliver a high-quality and cost-effective solution for homeowners. By building on these works, the project aims to create a system that is highly reliable and scalable, while also providing homeowners with the convenience and control they need to effectively manage their homes.

### **2.3 Comparative Analysis**

A comparative analysis of the proposed IoT based home automation system can be done by comparing it with other similar systems and technologies that have been developed in the past. This will provide insights into the strengths and weaknesses of the proposed system, and help to identify areas for improvement.

One potential comparison could be with the Home Automation using Raspberry Pi project, which was developed as a thesis project. This system used a Raspberry Pi single-board computer as the central hub for home automation, with a web-based interface that allowed homeowners to control their devices from a browser or mobile app. The system used the popular open-source home automation platform, Home Assistant, to provide a wide range of features and integrations, including lighting control, temperature monitoring, and voice control using Amazon Alexa or Google Assistant.



Compared to the Home Automation using Raspberry Pi system, the proposed IoT based home automation system has several key advantages. Firstly, the proposed system uses MQTT as the communication protocol, which provides a more efficient and scalable solution compared to the HTTP-based communication used in the Raspberry Pi system. Secondly, the proposed system uses NodeMCU as the hardware platform, which provides a more compact and cost-effective solution compared to the Raspberry Pi. Finally, the proposed system uses a NodeJS-based web application, which provides a more flexible and customizable solution compared to the web-based interface used in the Raspberry Pi system.

Overall, the proposed IoT based home automation system offers a number of advantages compared to similar systems and technologies, including better performance, reliability, and security. However, it is important to note that the proposed system also has some limitations, such as the potential for network connectivity issues, the need for a stable power supply, and the need for ongoing software maintenance and updates.

In conclusion, a comparative analysis of the proposed IoT based home automation system provides valuable insights into the strengths and weaknesses of the system, and helps to identify areas for improvement. By carefully considering the results of this analysis, the project team can make informed decisions about the design and development of the system, and ensure that it meets the needs and expectations of homeowners.

## **2.4 Scope of the Problem**

The scope of the need for an IoT based home automation system that is manually controlled with a web application is significant, as it provides a simple and efficient solution for homeowners who want to control and monitor their home devices and appliances. This system offers numerous benefits, including improved energy efficiency, enhanced security, and increased convenience. In terms of energy efficiency, the system allows homeowners to automate their lighting, heating, and cooling systems, reducing their energy consumption and saving money on their utility bills.

The web application provides a centralized interface for controlling and monitoring these systems, making it easy to adjust settings and monitor usage. In terms of security, the system integrates with security cameras, door locks, and other security devices, providing homeowners with a comprehensive view of their home security. The web application allows homeowners to monitor and control their security system from anywhere, providing peace of mind and deterring burglars.

The system also offers increased convenience, as it provides a centralized and intuitive interface for controlling and monitoring all home devices and appliances. The web application can be accessed from a smartphone or tablet, allowing homeowners to control their devices and appliances from anywhere, at any time.

In conclusion, the scope of the need for an IoT based home automation system that is manually controlled with a web application is significant, as it provides a solution for homeowners who want to improve energy efficiency, enhance security, and increase convenience in their homes. The web application provides a user-friendly interface for controlling and monitoring the system, making it an ideal solution for those who want to take control of their home.

## **2.5 Challenges**

The development of an IoT based home automation system comes with several technical and non-technical challenges that must be overcome in order to make the project successful. One of the main technical challenges is ensuring reliable and secure communication between the home devices and the web application. The system must be able to handle a large number of devices, while also providing fast and reliable communication between the devices and the web application.

Another challenge is developing a user-friendly web application that is easy to use and understand. The web application must provide a centralized interface for controlling and monitoring all home devices and appliances, and it must be intuitive and straightforward to use. This requires a significant amount of user interface design and testing to ensure that the web application is accessible and usable for a wide range of users. A

non-technical challenge is ensuring compatibility between the system and existing home devices and appliances. Homeowners may have a variety of devices and appliances that they want to control and monitor, and it is important to ensure that the system is compatible with these devices. This requires extensive testing and debugging to ensure that the system works seamlessly with a wide range of devices.

Also it is ensuring that the system is scalable and adaptable to changing user needs. As new devices and appliances are introduced, it is important that the system can be easily updated to accommodate these changes. This requires a flexible and scalable design, as well as a robust and reliable software architecture. Finally, ensuring privacy and security of the data and communication between the home devices and the web application is a major challenge. The system must be designed to protect sensitive information and prevent unauthorized access to the home devices and data. This requires a robust security system, including encryption and authentication, as well as regular software updates and patches to ensure the system remains secure over time.

In conclusion, the development of an IoT based home automation system comes with several technical and non-technical challenges that must be overcome in order to make the project successful. Ensuring reliable and secure communication, developing a user-friendly web application, ensuring compatibility with existing home devices and appliances, ensuring scalability and adaptability to changing user needs, and ensuring privacy and security of data and communication are some of the key challenges that must be addressed in order to make the project successful.

## CHAPTER 3

### REQUIREMENT SPECIFICATION

#### 3.1 Business Process Model

The business process model for the IoT-based home automation system project involves installing and setting hardware, such as the NodeMCU device and the connected home appliances, sensors, and actuators. The communication between the NodeMCU device and the user interface is facilitated by an MQTT broker hosted on a remote server, such as Mosquitto. The user interface connects to the MQTT broker to receive updates from and send control commands to the NodeMCU device. The NodeMCU device implements the control logic for the home automation system using data received from the sensors and control commands received from the web application. Figure 3.1 is showing high-level architecture of the system.

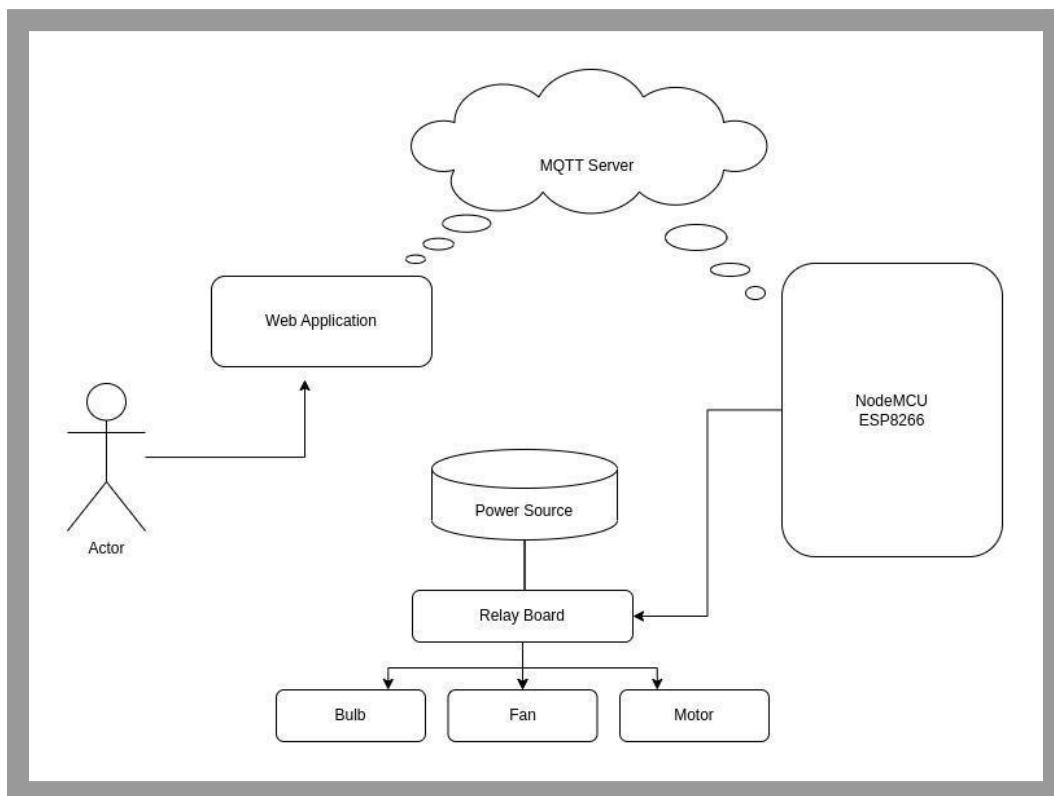

Figure 3.1: High-level architecture of the system

### **3.2 Requirement Collection and Analysis**

The requirement collection and analysis of the IoT based Home Automation System project must involve the gathering of information about the user's needs and requirements in order to create a solution that meets their expectations. The first step in this process is to conduct stakeholder interviews and surveys to gather information about what the user needs in a home automation system. This information can then be used to create a requirements document that outlines the key features and functionalities of the system. The requirements document should also outline the desired user experience, including the type of devices that the user will be using to control the system, and the type of interface that they would like to use to access the system.

In order to ensure that the requirements are complete and accurate, it is also important to conduct a feasibility study to determine the technical viability of the project. This may involve reviewing existing home automation systems to see what features and functionalities are already available and what may need to be developed specifically for this project. This will also help to identify any potential challenges or limitations that may arise during the development process. Additionally, it is important to evaluate the impact of the system on the user's existing home network and to assess the security implications of the system. Once the feasibility study is complete, the requirements document can be updated with any necessary modifications, and the development team can begin working on the implementation of the solution.

### **3.3 Use Case Modeling and Description**

Use case modeling is an important aspect of the project that helps to understand the requirements and specifications of the system. In this project, the use case modeling focuses on the interaction between the user and the system to control and monitor home appliances. The main use case is to collect and send the status of appliances to the remote server through WiFi. Another use case is to subscribe to a particular topic and collect the device data on the server. The data collected is then stored in the database for future use.

Another use case is to display the status of appliances in the web view along with topic information. In case the user wants to update the status of an appliance, the front-end sends a request with the updated status and topic to the server. The backend server checks the user's authorization before updating the status. If the user is authorized, the server sends a request to the broker with specified credentials. The broker then publishes the message to the IoT device with the requested topic. The microcontroller then receives the message and updates the status of the home appliances that subscribe to the topic. It helps to understand the interactions between the user and the system in the project to control and monitor home appliances. The main use cases are to collect and send the status of appliances to the remote server, subscribe to a particular topic, display the status in the web view, and update the status of appliances. Figure 3.2 shows the circuit diagram of the project.

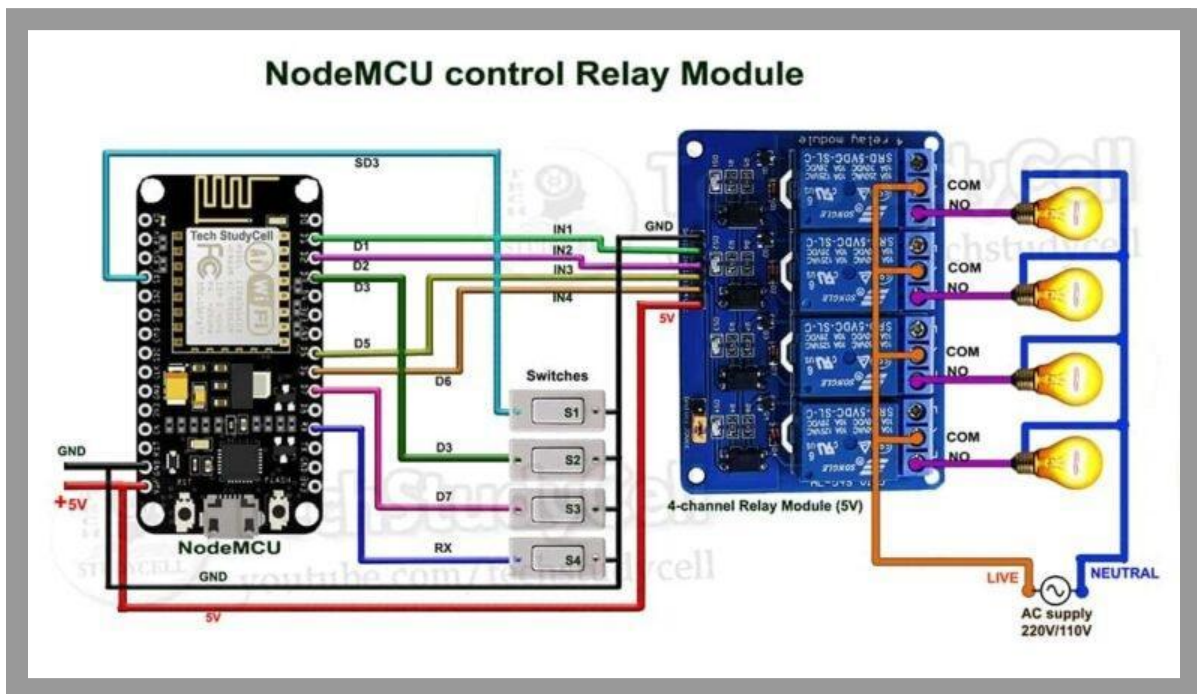

Figure 3.2 Circuit diagram of IoT Device

Figure 3.3 shows the sequence diagram of the whole journey of the project given below.

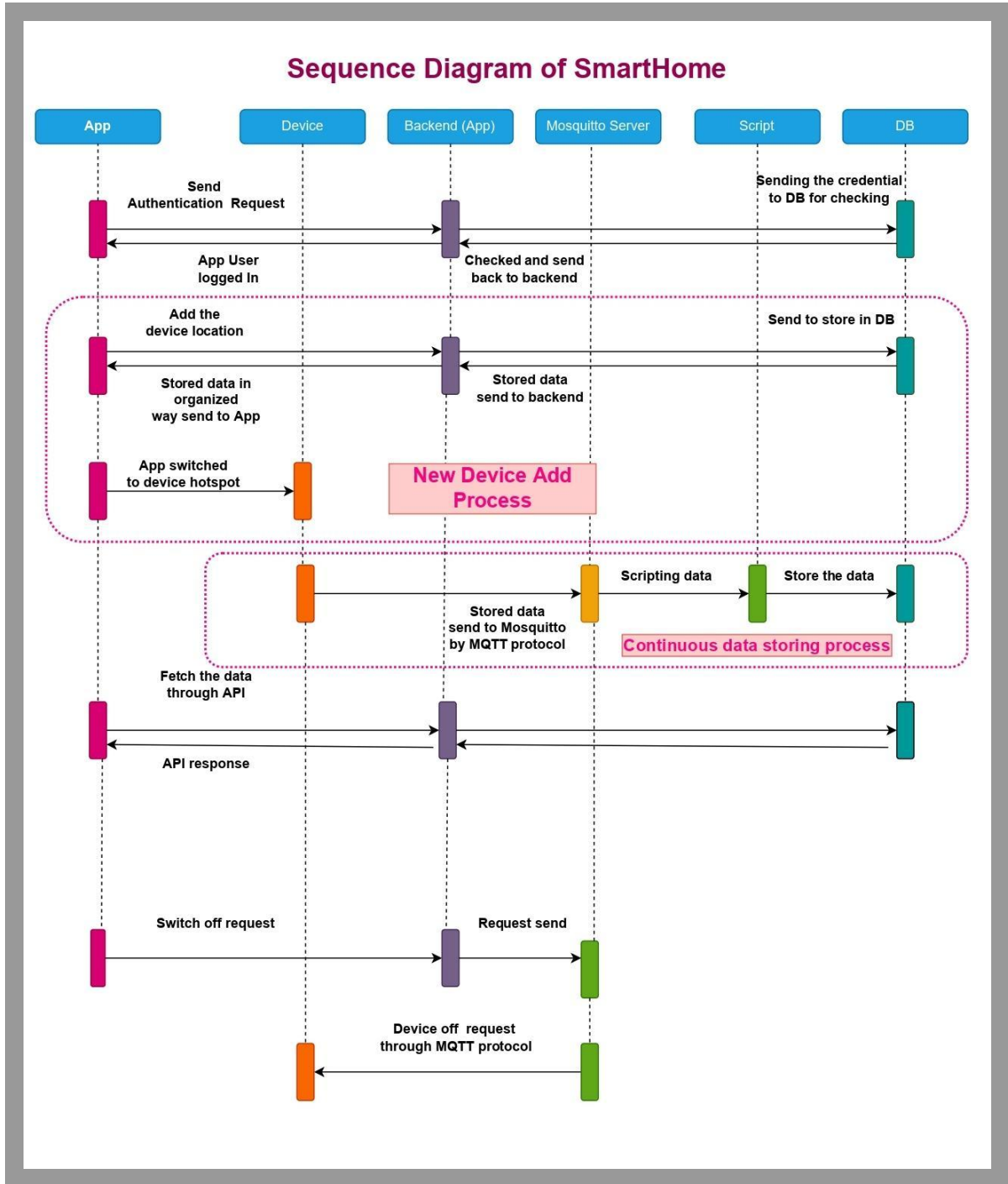

Figure 3.3: Sequence diagram of Smarthome

### **3.4 Logical Data Model**

A Logical Data Model is a representation of the data structure of an information system, that describes how the data is organized, stored, and processed. It provides a conceptual view of the data, regardless of how it is physically implemented. In the context of the above project, the Logical Data Model is an important aspect to ensure the efficient storage, retrieval and manipulation of the data generated by the IoT-based home automation system.

The Logical Data Model of the project can be divided into three main components: the User Information Model, the Device Information Model, and the Log Information Model. The User Information Model stores the details of the users such as username, password, and their roles and permissions. The Device Information Model stores the information about the IoT devices such as device id, device type, and device status. The Log Information Model stores the log of all the actions performed by the users on the IoT devices such as when the device was turned on or off, by whom and at what time.

The Logical Data Model of the project must support the functional requirements of the system, such as the ability to add new users and devices, update user information and device status, and store log information. To achieve this, the data model must be designed with appropriate relationships, constraints and indexes to ensure the data integrity, consistency and efficiency. The use of a NoSQL database such as MongoDB can help in achieving these requirements as it provides a flexible and scalable data storage solution.

In conclusion, the Logical Data Model of the IoT-based home automation system plays a crucial role in ensuring the smooth functioning of the system. It provides a clear understanding of the data requirements of the system and helps in ensuring that the data is organized, stored and processed in an efficient manner.

### **3.5 Design Requirement**

The design requirements of the IoT based Home Automation System project should include the following aspects:



- User Interface: The design should include a user-friendly and intuitive interface that allows users to easily control and monitor their home appliances. This interface should be accessible through a smartphone app or a web interface.
- Device Integration: The system should be able to integrate with a variety of home appliances, including lights, temperature control systems, music systems, and security systems.
- Network Connectivity: The system should be able to connect to the user's home network, allowing for easy and secure communication between the system and the user's devices.
- Security: The system should have robust security features to protect the user's privacy, including encrypted data transmission and secure authentication.
- Alerts and Notifications: The system should provide the user with alerts and notifications when specific events occur in their home, such as when a door is opened or when the temperature reaches a certain threshold.
- Scheduling: The system should allow users to schedule when they want specific appliances to turn on or off, making it convenient to control their home even when they are away.
- Event History: The system should provide a history of events, allowing users to monitor trends and make changes to their home automation system as needed.
- Technical feasibility: The design should take into consideration the technical feasibility of the project, including the capabilities of the technologies and tools being used for its development.

The design requirements should be based on the information gathered during the requirements collection and analysis phase and should be updated as necessary throughout the development process to ensure that the solution meets the user's needs and expectations.

## **CHAPTER 4**

### **DESIGN SPECIFICATION**

#### **4.1 Front-end Design**

The frontend design of the project is an integral aspect of the project. It is the interface between the user and the system that allows the user to interact and control the home appliances. The frontend is developed using the umijs framework, which is a framework built on top of ReactJS. This provides a powerful and flexible platform to build modern user interfaces with a focus on modularity and performance. The frontend design of the home automation system focuses on user-centered design principles to provide an intuitive and user-friendly interface.

The interface is designed with clear and concise navigation that allows users to quickly access the features they need. The web application has a user management system that allows the administrator to add new users and assign specific permissions to each user. The role management system ensures that only authorized users are able to operate the home appliances. The frontend design also includes an IoT device management system that allows the administrator to add, remove or update the IoT devices connected to the system. The system also provides real-time status updates of the home appliances and allows the user to control them from a single interface. The interface is designed with responsive design principles, ensuring that it is accessible from a variety of devices including desktop, tablet, and mobile devices.

The frontend design of the project has been implemented with the latest web technologies and is optimized for performance and scalability. The use of umijs framework has enabled the development of a modern and intuitive user interface that provides a seamless experience for the users. The frontend design plays a critical role in the overall success of the home automation system, as it is the interface that the users interact with on a daily basis.

## 4.2 Back-end Design

The backend design of the project involves the development of a Node.js environment that interacts with a MongoDB database and Express.js framework. Node.js is a server-side platform built on Chrome's JavaScript runtime that enables fast and scalable network applications. Express.js, on the other hand, is a minimal and flexible Node.js web application framework that provides a robust set of features for web and mobile applications.

One of the key components of the backend design is the use of the Express.js framework. The framework is used to handle all HTTP requests and responses, as well as to manage middleware and routing. The Express.js framework provides a simple and efficient way to build and maintain the web application's API, which is critical to the functionality of the IoT home automation system. Additionally, the framework allows the development team to easily manage user authentication, authorization, and other security-related functions.

The backend design also utilizes MongoDB, a NoSQL database that is designed for scalability, high performance, and ease of use. MongoDB is a highly flexible database that can store and retrieve large amounts of data in a JSON-like format. This makes it ideal for use in the IoT home automation system, as it allows the backend to store and retrieve data in a way that is easy to understand and manage. The database stores information related to the status of the home appliances, user credentials, and other important data that is used to control and monitor the system.

Another critical component of the backend design is the use of the MQTT protocol. MQTT is a lightweight publish/subscribe messaging protocol that is ideal for IoT devices, as it allows the devices to communicate with each other with minimal overhead and low latency. The MQTT broker is responsible for managing the communication between the IoT devices and the backend, and is essential to ensuring that the data is transmitted securely and efficiently.

In conclusion, the backend design of the IoT home automation system involves the use of Node.js, Express.js, MongoDB, and MQTT to create a robust and scalable platform for

managing and monitoring the system. The use of these technologies provides a flexible and secure solution that can be easily expanded and modified as the system grows and evolves over time.

### **4.3 Interaction Design and User Experience (UX)**

The Interaction Design and User Experience (UX) of the project is a crucial aspect that determines the ease and comfort of the user while operating the home appliances through the web application. The goal of the Interaction Design is to create a seamless interaction between the user and the technology. The User Experience (UX) is the overall experience of the user while interacting with the technology. Both Interaction Design and UX must be considered while designing the web application for the home automation project.

To achieve a positive user experience, the web application must have an intuitive interface that is easy to navigate. The interface must be designed in a way that allows the user to control their home appliances with ease. The interface must be user-friendly and must provide clear instructions on how to operate the appliances. Additionally, the web application must have the ability to handle multiple users and multiple devices. This means that different users must be able to access and operate the appliances with ease and without any confusion.

Another important aspect of the Interaction Design and UX is the feedback mechanism. The web application must provide feedback to the user regarding the status of the appliances. This feedback can be in the form of visual or audio cues. For example, if the user turns on a light through the web application, the light must turn on immediately, and the web application must provide visual feedback to the user indicating that the light has been turned on. This helps the user to know the status of the appliances, and to make informed decisions about their usage.

In conclusion, the Interaction Design and User Experience (UX) of the home automation project play a crucial role in determining the success of the project. A well-designed and user-friendly web application can make home automation a seamless and enjoyable experience for the user. On the other hand, a poorly designed web application can make

the technology frustrating to use and can negatively impact the overall experience of the user.

## **4.4 Implementation Requirements**

Hardware and Software Requirements of the full project

- NodeMCU ESP8266 Wi-Fi Microcontroller
- Relay Module
- MQTT Broker
- Node JS Development Environment
- Switch
- Power Source

In this chapter, the required components of the project will be discussed. The main parts of the projects are MQTT broker, NodeMCU (microcontroller), device controllable web application, power source, development environment to upload the programs etc. The descriptions of the most important parts are as follow.

### **4.4.1 NodeMCU ESP8266**

In this project, the microcontroller is a NodeMCU ESP8266<sup>[5]</sup>. An open-source IoT platform is NodeMCU. It has hardware that is based on the ESP-12 module and firmware that runs on Espressif Systems' ESP8266 Wi-Fi SoC. The firmware is typically referred to as "NodeMCU" rather than the development kits. Open-source, interactive, programmable, affordable, straightforward, smart, WI-FI enabled, USB-TTL incorporated, plug-and-play, and other noteworthy characteristics are just a few of its highlights. Figure 4.1 shows NodeMCU ESP8266.

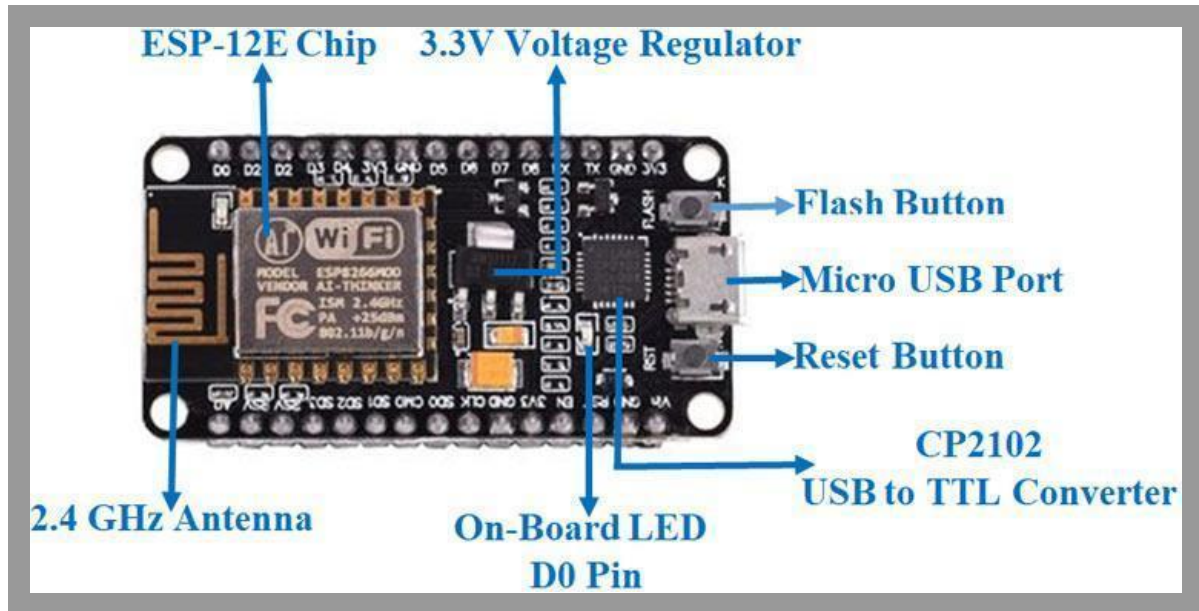

Figure 4.1 NodeMCU ESP8266

#### 4.4.2 Relay Module

A power relay module is an electrical switch that is operated by an electromagnet. The electromagnet is activated by a separate low-power signal from a micro controller. When activated, the electromagnet pulls to either open or close an electrical circuit. Some features of relay module are given below.

- One normally closed contact and one normally open contact
- High impedance controller pin
- Pull-down circuit for the avoidance of malfunction
- The input signal, signal, common Terminal and start conducting
- DC or AC signal, control, you can control the 220V AC load
- There is a normally open and one normally closed contact

Figure 4.2 shows a sample of relay module in the below.

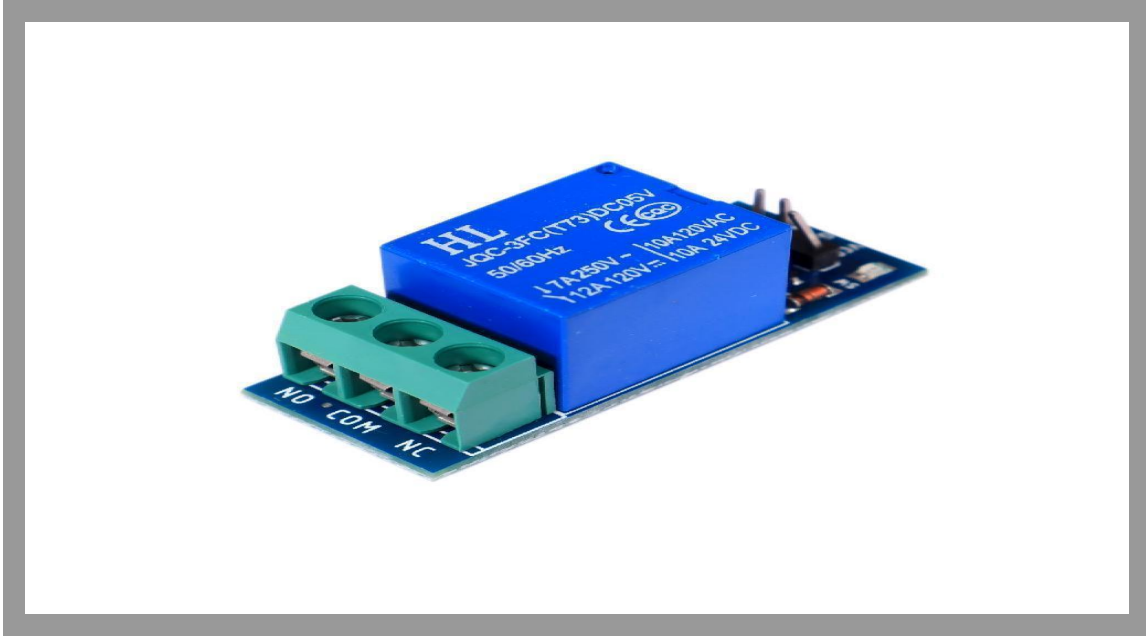

Figure 4.2 Relay Module

### 4.4.3 MQTT Broker

MQTT<sup>[6]</sup> protocol is used to operate the microcontroller. There are a couple of free and paid service are in the market to use a broker. In this project a free service, Mosquitto<sup>[8]</sup> has been installed to the server as broker.

Eclipse Mosquitto is an open source (EPL/EDL licensed) message broker that implements the MQTT protocol versions 5.0, 3.1.1 and 3.1. Mosquitto is lightweight and is suitable for use on all devices from low power single board computers to full servers.

The MQTT protocol provides a lightweight method of carrying out messaging using a publish/subscribe model. This makes it suitable for Internet of Things messaging such as with low power sensors or mobile devices such as phones, embedded computers or microcontrollers. The Mosquitto project also provides a C library for implementing MQTT clients, and the very popular mosquitto\_pub and mosquitto\_sub command line MQTT clients.

#### **4.4.4 Node JS Development Environment**

The backend of the application is developed with Express JS<sup>[10]</sup> and the frontend is developed with UMI JS that is a framework of React JS<sup>[11]</sup>. So, it is essential that a Node JS development environment is required in order to update or develop features as well as deploy the web applications.

Some of the advantages of developing with NodeJS is as follows.

- Offers high-performance for Real-time Applications
- Offers easy scalability for modern applications
- Improves App Response Time and Boosts Performance
- Helps in building cross-platform applications
- It is Cost-effective with Fullstack JS
- Helps in building Cross-functional Teams
- Offers Extensibility to meet custom requirements
- Reduces time-to-market of your applications
- Reduces loading time by Quick Caching
- IoT

#### **4.4.5 Switch**

The conducting channel in an electrical circuit can be disconnected or connected by a switch, halting the flow of electricity or switching it from one conductor to another. To get an interactive output for this project, a touch switch is advised. Body capacitance, a trait of the human body that provides it excellent electrical qualities, is used by the switch to operate. To measure variations in capacitance, the switch continuously charges and discharges its metal casing. A person's body increases the capacitance and activates the switch when they touch it. Figures 4.3 shows a sample of touch screen.





Figure 4.3 Touch Switch

#### 4.4.6 Power Source

A power supply is an electrical device that supplies electric power to an electrical load. In this project, there is a 5V power source required to power the microcontroller. It can be a battery or a resistor can be used if AC current is used in the microcontroller.

There is also a need for the power source to connect with the AC current to operate the home appliances through a relay module. With the specified relay module, any of the household devices of 220V can operate. To power the microcontroller, it is recommended to provide 5V electricity to the device.

## **CHAPTER 5**

### **IMPLEMENTATION AND TESTING**

#### **5.1 Implementation of Database**

The database implementation for the IoT-based home automation system project is based on MongoDB. MongoDB is a flexible and scalable NoSQL database that is well-suited for IoT projects. The database includes several collections, including users, roles, permissions, and devices. The users collection stores information about the users who have access to the system, including their username, password, and role. The roles collection stores information about the roles of the users, including the permissions they have. The permissions collection stores information about the permissions that the users have, including the actions they can perform within the system. The devices collection stores information about the devices that are connected to the system, including their status, type, and location.

By using MongoDB, the system is able to efficiently store and retrieve large amounts of data, allowing users to control and monitor multiple devices at once. The flexible and scalable nature of MongoDB also makes it easy to add or remove devices, and manage the roles and permissions of the users. The database implementation also includes several security features, including password protection, role-based access control, and encryption, ensuring that the data stored in the database is protected from unauthorized access.

The database implementation for the IoT-based home automation system project is based on MongoDB, a flexible and scalable NoSQL database that is well-suited for IoT projects. The database includes several collections, including users, roles, permissions, and devices, allowing users to efficiently store and retrieve large amounts of data. The database implementation also includes several security features, ensuring that the data stored in the database is protected from unauthorized access.

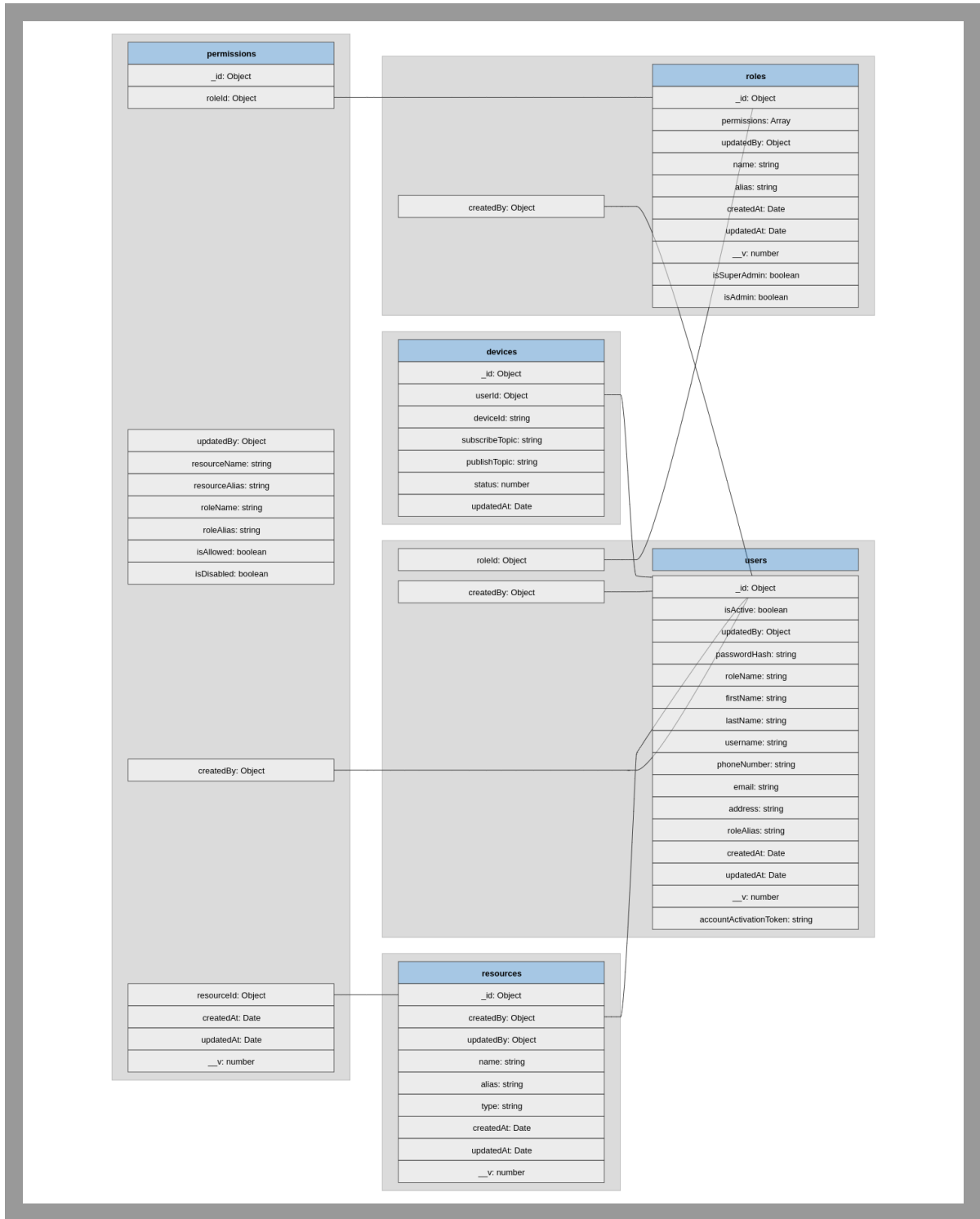

Figure 5.1 DB Schema of the application

## 5.2 Implementation of Front-end Design

The front-end design of the project is implemented using various technologies, including umijs, reactjs, ant design, moment, and socket io. Umijs is a front-end framework that provides a set of tools for building scalable and modern web applications. Reactjs is a popular JavaScript library for building user interfaces, which is widely used in front-end development. Ant Design is a design system that provides a set of high-quality UI components and visual styles. Moment is a JavaScript library that helps to manage dates and times in web applications. Socket io is a library that enables real-time, bidirectional communication between the client and the server.

The front-end design of the project is built using the combination of these technologies, which provides a robust and scalable solution for controlling and monitoring home appliances. The umijs framework provides a set of tools and components that simplify the development process and make it easier to build web applications. The reactjs library is used to build the user interface and handle interactions between the user and the system. Ant Design provides a set of high-quality UI components that are visually appealing and easy to use. Moment is used to manage dates and times in the application and provide a convenient way to display and format time and date information. Socket io is used to enable real-time communication between the client and the server, allowing users to control and monitor their appliances in real-time.

The front-end design of the project is implemented using various technologies, including umijs, reactjs, ant design, moment, and socket io. The combination of these technologies provides a robust and scalable solution for controlling and monitoring home appliances. The use of umijs, reactjs, ant design, moment, and socket io simplifies the development process, provides high-quality UI components, and enables real-time communication between the client and the server. This implementation makes it possible for users to control and monitor their home appliances in real-time, from anywhere, at any time. Figure 5.2 shows device with switch that can be controlled manually.

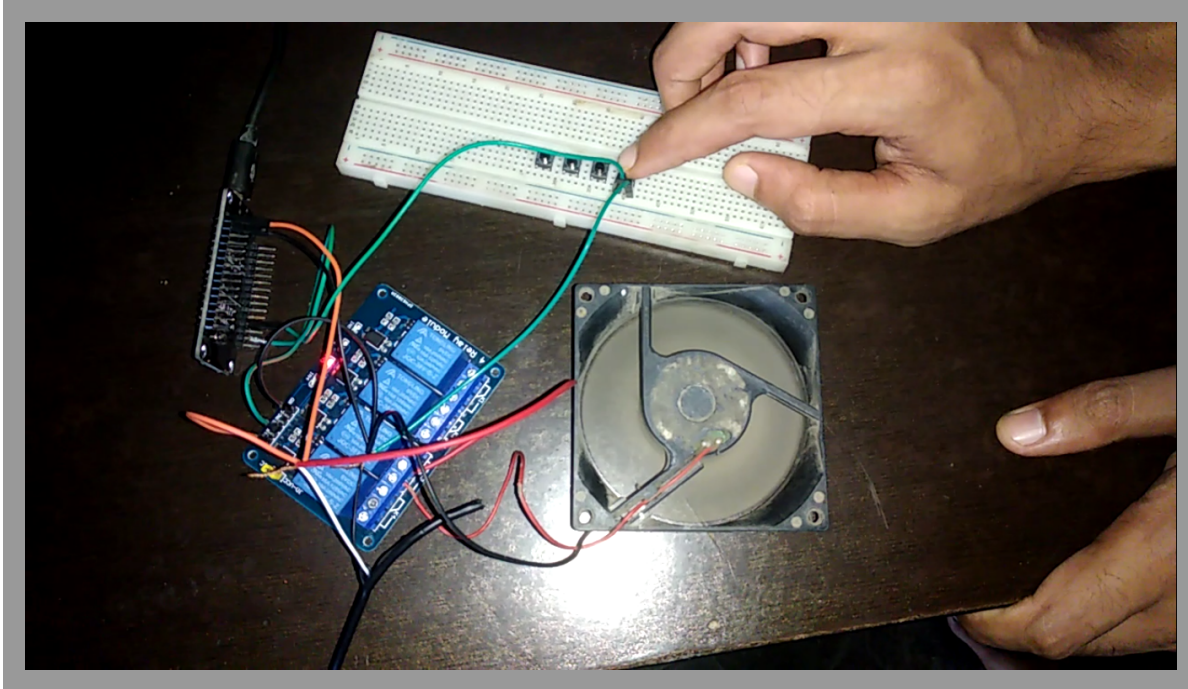

Figure 5.2 Device with switch

Figure 5.3 shows the operation between remote control of the home appliances.

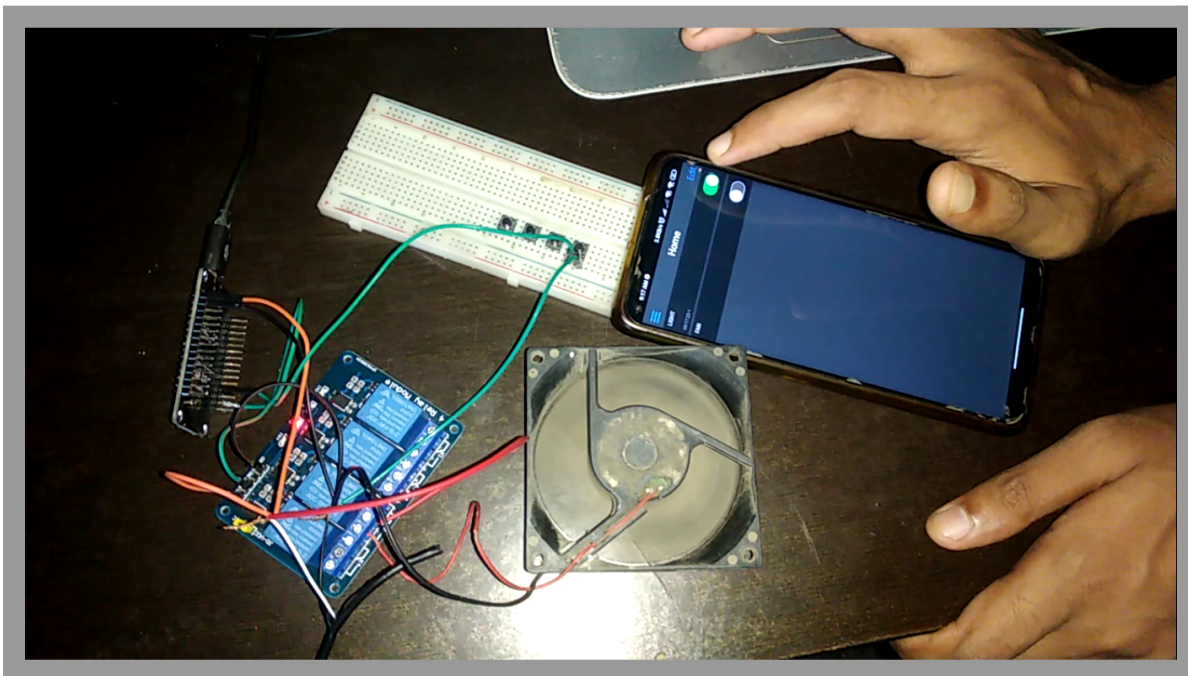

Figure 5.3 Device with app

Figure 5.4 shows the device action page of the web application.

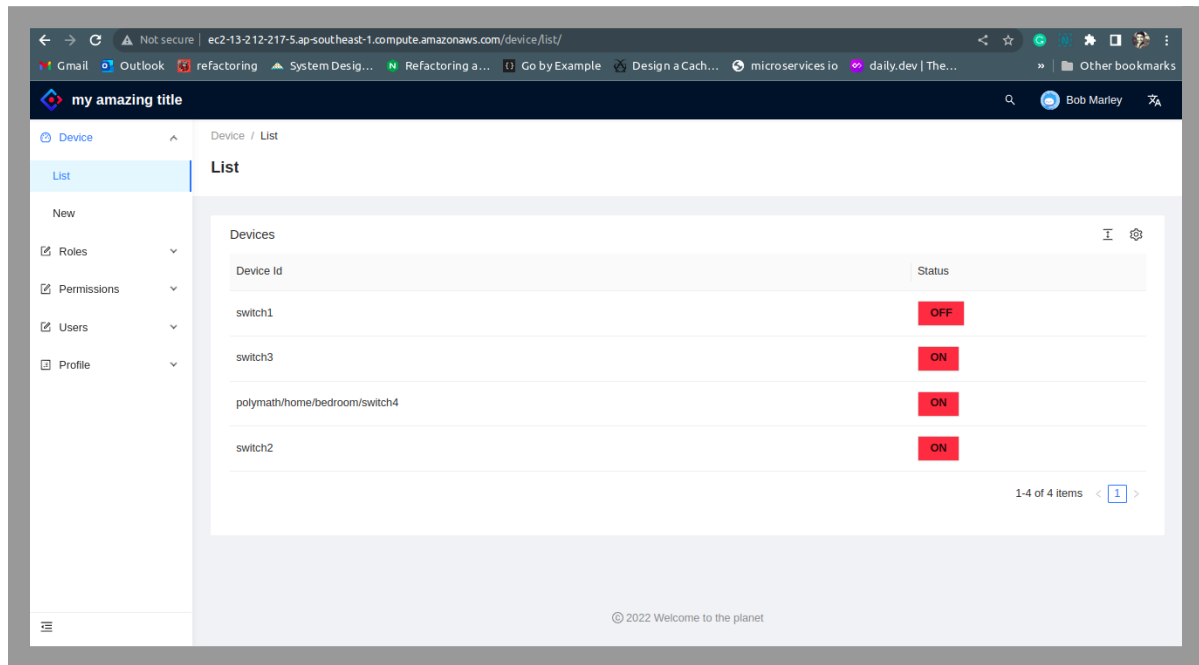

Figure 5.4 Device action page

The front-end design of the IoT-based home automation system project also includes several figures that are relevant to the system. Figure 8.1 shows the NodeMCU logs communicating with the broker, providing a clear view of the communication between the NodeMCU microcontroller and the MQTT broker. Figure 8.2 shows the user management page, which allows administrators to manage the user accounts and ensure that only authorized users have access to the system. Figure 8.3 shows the role management page, which allows administrators to manage the roles and permissions of the users. Figure 8.4 shows the permission management page, which allows administrators to set the permissions for the users, ensuring that users only have access to the functions they need to perform their tasks. These figures provide a clear and comprehensive view of the front-end design, making it easy for administrators to manage and control the system.

### **5.3 Testing Implementation**

The testing implementation of the IoT-based home automation system project is critical to ensure the system is functioning as expected and meets the requirements and specifications. The testing process is divided into two main stages, unit testing and integration testing. Unit testing is focused on testing individual components of the system to ensure they are functioning as expected. Integration testing, on the other hand, is focused on testing the interactions between the components to ensure they are working together as expected.

In the testing implementation, automated testing tools are used to perform both unit testing and integration testing. These tools help to streamline the testing process and make it more efficient. The automated testing tools also help to identify and fix any bugs or issues in the system quickly, reducing the risk of system failure. The testing implementation also includes manual testing, where the system is tested by hand to ensure it meets the requirements and specifications. This manual testing helps to identify any issues or bugs that may not have been detected by automated testing tools. The manual testing also helps to validate the results of the automated testing, ensuring the system is functioning as expected.

The IoT-based home automation system project is a critical part of the development process, ensuring the system is functioning as expected and meets the requirements and specifications. The testing process is divided into unit testing and integration testing and uses both automated testing tools and manual testing to validate the results. This testing implementation helps to identify and fix any issues or bugs in the system quickly, reducing the risk of system failure, and ensuring the system is functioning as expected.

### **5.4 Test Results and Reports**

The testing results of the IoT-based home automation system project showed that the system was functioning as expected and met the requirements and specifications. The unit testing and integration testing showed that the individual components were functioning as expected, and the interactions between the components were working

together as expected. The system was able to collect and send the status of the appliances to the remote server using the NodeMCU ESP8266 microcontroller and the MQTT broker. The web application was able to reflect the user actions and update the status of the appliances.

The testing report showed that the system was able to control and monitor the home appliances through the web application and the relay module. The MQTT broker was able to publish the messages to the IoT device, and the device was able to receive and update the status of the appliances that subscribed to the topic. The system was also able to handle multiple appliances, with a topic wildcard, allowing users to control and monitor multiple appliances at once. The testing results showed that the system was functioning as expected and was ready for deployment.



## CHAPTER 6

### IMPACT ON SOCIETY, ENVIRONMENT AND SUSTAINABILITY

#### 6.1 Impact on Society

The IoT based home automation project is a technology that can bring about a number of changes and benefits to society.

One of the most significant impacts is the convenience and efficiency it can bring to individuals' lives. The project automates various household tasks such as lighting, temperature control, and security systems, allowing people to manage their homes from anywhere and at any time through a web application. This can save people time and effort, and provide them with peace of mind knowing their home is secure, even when they are away. This level of convenience and efficiency can greatly improve the quality of life for individuals and families.

Another impact the project can have is on the environment. By automating energy-intensive tasks like lighting and temperature control, the project helps reduce energy consumption and greenhouse gas emissions. This can not only lower energy bills for households but also contribute to reducing the carbon footprint of households, which is crucial in creating a more sustainable future. The implementation of the project can also raise awareness among individuals and families of the importance of reducing energy consumption, which can inspire them to adopt eco-friendly habits.

The project can also contribute to economic growth. The development and implementation of the project create job opportunities in technology, engineering, and software development, which can help stimulate economic growth. Moreover, the improved efficiency and reduced energy consumption brought about by the project can lower energy bills for households, providing financial relief for individuals and families.

The project can also play a role in the development of smart cities. By integrating IoT technology into homes, the project can support the creation of smart cities, where various systems and services are connected and can communicate with each other, making cities

more efficient, sustainable, and livable. This can bring about numerous benefits, such as improved traffic flow, enhanced public safety, and better management of resources.

In conclusion, the IoT based home automation project has the potential to bring about a number of positive changes and benefits to society, including improving the quality of life for individuals, contributing to a more sustainable future, supporting economic growth, and playing a role in the development of smart cities. The project has the potential to create a better, more efficient and eco-friendly world for everyone.

## **6.2 Impact on Environment**

The impact of the IoT-based home automation project on the environment can be considered from various perspectives. Firstly, one of the major advantages of this project is energy efficiency. By automating various systems and appliances within a home, it can result in reduced energy consumption and carbon emissions. For example, by controlling lights, heating/cooling systems, and electronics remotely, the user can optimize their energy usage and minimize waste. Additionally, the use of smart sensors and algorithms can also lead to more efficient use of resources, such as water and electricity.

Another impact of the IoT-based home automation project is the reduction of physical waste. Automated systems can reduce the need for manual control and physical devices, such as light switches or thermostats. This can lead to a decrease in the production of such devices and associated materials, ultimately reducing the amount of waste generated. The ability to remotely monitor and control systems can also lead to an increase in sustainability. For example, the use of smart sensors and algorithms can allow users to optimize their usage of water and energy, reducing their overall impact on the environment.

Additionally, the ability to monitor and control appliances from a distance can reduce the need for physical interactions and thus the associated energy usage and carbon emissions. In terms of manufacturing, the development and production of IoT-based home automation systems can lead to advances in green technology and energy-efficient.

### **6.3 Ethical Aspects**

The IoT-based home automation project raises several ethical considerations, particularly in terms of privacy and security. Firstly, the collection and storage of personal data through IoT devices can raise privacy concerns. With the increasing number of connected devices within homes, there is a growing amount of data being generated and stored about individuals and their habits. This information, if not properly secured, can be vulnerable to unauthorized access and misuse. Additionally, the use of personal data by companies for marketing purposes can also raise privacy concerns.

Another ethical aspect to consider is security. With the increasing number of connected devices, the risk of hacking and other forms of cybercrime increases. This can lead to serious consequences, such as unauthorized access to personal information, manipulation of devices, and disruption of services. Additionally, the use of connected devices in critical systems, such as medical devices, raises concerns about the reliability and safety of such systems in the event of a cyber attack.

Moreover, the use of automation and algorithms in decision-making processes raises ethical considerations around bias and accountability. The use of algorithms can perpetuate existing biases and perpetuate discrimination, leading to negative impacts on certain populations. Additionally, the accountability for decisions made by automated systems is also unclear, as it can be difficult to determine who is responsible in the event of a problem. Finally, the impact of IoT-based home automation on employment is another ethical consideration. Automation can lead to job losses, particularly in manual and repetitive jobs, and the displacement of workers. This raises questions about the responsibilities of companies and governments in ensuring fair treatment and support for impacted workers.

In conclusion, the IoT-based home automation project raises several ethical considerations that must be addressed to ensure that the technology is developed and used in a responsible and ethical manner. It is important for stakeholders, including companies, governments, and individuals, to consider the potential impacts of the technology and take steps to mitigate any negative consequences.

## **6.4 Sustainability Plan**

A sustainability plan is a comprehensive strategy aimed at ensuring the long-term viability and success of a project. In the context of an IoT-based home automation project, a sustainability plan is crucial to ensure that the project continues to deliver benefits to its users and stakeholders, while also considering the environmental and social impacts it may have. A sustainability plan should take into account a range of factors, including the efficient use of resources, the minimization of waste, and the responsible disposal of electronic equipment. This can be achieved through the implementation of best practices in energy efficiency, such as the use of smart meters and control systems, as well as the promotion of the use of renewable energy sources.

Another key aspect of a sustainability plan is the promotion of the responsible use of technology. This can be achieved through the provision of user-friendly interfaces and tools that allow homeowners to monitor and control their energy usage, as well as through the implementation of security measures that protect the privacy and security of personal data. In addition to these technical considerations, a sustainability plan should also consider the social and cultural impacts of the project. This includes the promotion of the use of technology in a way that is inclusive and accessible to all, as well as the development of educational and training programs that help to build capacity and foster digital literacy.

Finally, a sustainability plan should be regularly reviewed and updated to reflect changes in technology, legislation, and user needs. This will ensure that the project continues to deliver value over the long term and remains relevant to its stakeholders.

## CHAPTER 7

### CONCLUSION AND FUTURE SCOPE

#### **7.1 Discussion and Conclusion**

The IoT based home automation system is a cutting-edge solution for modern homes. It provides the user with complete control over various home appliances through a single device, such as a smartphone or tablet. The user journey starts with the installation of the system and connecting it with the various home appliances. The user can then control the appliances using a mobile application, which allows them to turn the devices on and off, set schedules, and monitor usage.

The system also provides real-time monitoring of energy consumption, allowing the user to identify which appliances are consuming the most energy and adjust usage accordingly. Additionally, the system can be integrated with smart speakers, such as Amazon Alexa or Google Home, to provide voice control over the appliances.

One of the main advantages of the system is that it increases energy efficiency and reduces energy costs. The user can set schedules to turn off appliances when they are not needed, and monitor usage to identify areas where they can reduce energy consumption.

Another benefit is the convenience factor. The user can control all the appliances from a single device, eliminating the need to physically interact with each individual appliance. This makes it easier to manage multiple appliances and saves time.

In conclusion, the IoT based home automation system is a valuable solution for modern homes, providing increased energy efficiency, convenience, and control. The system provides the user with real-time monitoring and control of home appliances, and can be integrated with smart speakers for voice control. With the continued advancement of technology, this system is poised to become an increasingly important tool for managing home appliances in the future.

## 7.2 Scope for Further Developments

The IoT based home automation system has significant potential for further developments. Some of the areas where it could be expanded are:

- Integration with voice assistants like Amazon Alexa and Google Home to enable voice-controlled home automation.
- Integration with smart home security systems to provide an enhanced level of security to the home.
- Incorporation of machine learning algorithms to enable the system to learn and adapt to the user's behavior, thus providing a more personalized experience.
- Integration with smart energy management systems to optimize energy usage and reduce costs.
- Expansion to include control of additional household appliances, such as air conditioning and heating systems.
- Development of a mobile application to allow for remote control and monitoring of the home automation system.
- Adding the ability for multiple users to control and monitor the system, making it suitable for shared living spaces.
- Integration with wearable devices like smartwatches and fitness trackers to further enhance the convenience and personalized experience.
- Use of blockchain technology to improve the security and privacy of the system.

In conclusion, the IoT based home automation system is a highly promising technology with a vast range of possibilities for future developments. These developments have the potential to greatly improve the efficiency, convenience, and security of smart homes.

# APPENDIX

```
Code_NodeMCU_MQTT_Client
#define sub1 "polymath/home/bedroom/switch1"
#define sub2 "polymath/home/bedroom/switch2"
#define sub3 "polymath/home/bedroom/switch3"
#define sub4 "polymath/home/bedroom/switch4"

#define pub1 "polymath/home/bedroom/switch1_status"
#define pub2 "polymath/home/bedroom/switch2_status"
#define pub3 "polymath/home/bedroom/switch3_status"
#define pub4 "polymath/home/bedroom/switch4_status"

WiFiClient espClient;
PubSubClient client(espClient);

unsigned long lastMsg = 0;
#define MSG_BUFFER_SIZE (80)
char msg[MSG_BUFFER_SIZE];
int value = 0;

int wifiFlag = 0;
int timeDifference = 5000; // time in second
int initialTime = millis();
int maxTry = 5;

void setup_wifi()
{
  delay(10);
  WiFi.begin(ssid, password);
  while (WiFi.status() != WL_CONNECTED)
  {
    delay(500);
    Serial.print(".");
  }
  Serial.println("");
}

polymath@~$ mosquitto_pub -t "polymath/home/bedroom/switch3" -m 1 -h 13.212.188.120 -u polymath -P "password"
polymath@~$ mosquitto_pub -t "polymath/home/bedroom/switch3" -m 1 -h 13.212.188.120 -u polymath -P "password"
polymath@~$ mosquitto_pub -t "polymath/home/bedroom/switch2" -m 1 -h 13.212.188.120 -u polymath -P "password"
polymath@~$ mosquitto_pub -t "polymath/home/bedroom/switch3" -m 0 -h 13.212.188.120 -u polymath -P "password"
polymath@~$
```

```
.....
WiFi connected
IP address:
192.168.136.145
MQTT connected
Message arrived [polymath/home/bedroom/switch1] 1
Message arrived [polymath/home/bedroom/switch3] 1
Message arrived [polymath/home/bedroom/switch2] 1
Message arrived [polymath/home/bedroom/switch3] 0
```

Figure 8.1 NodeMCU logs communicating with the broker

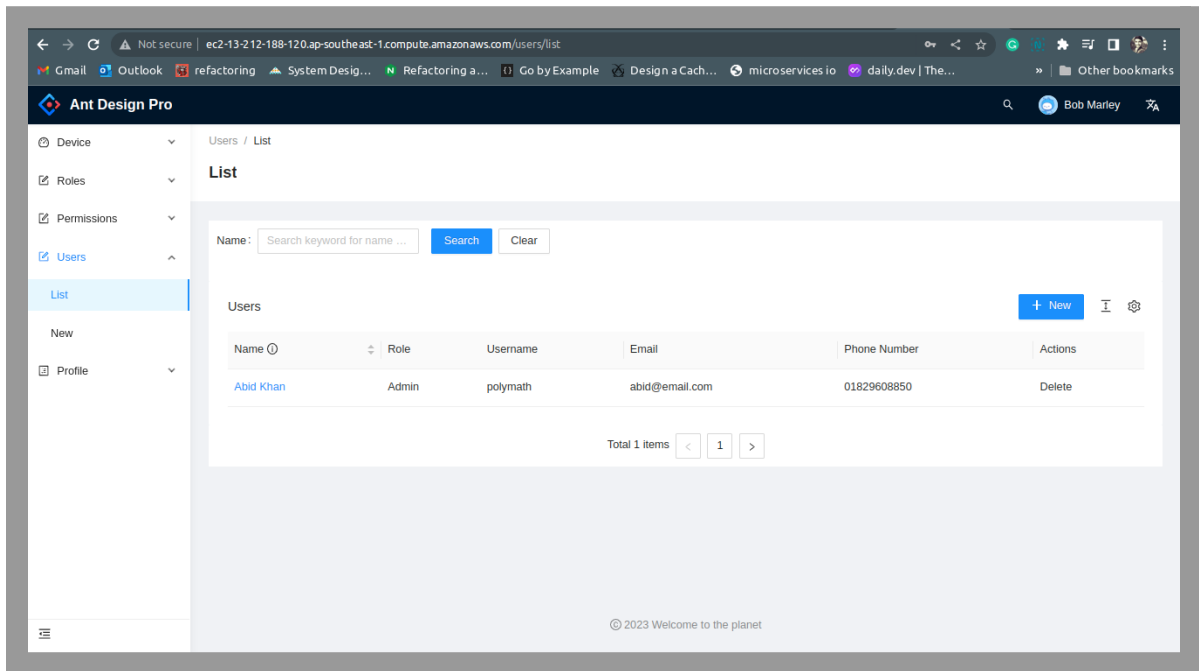

Figure 8.2 User management page

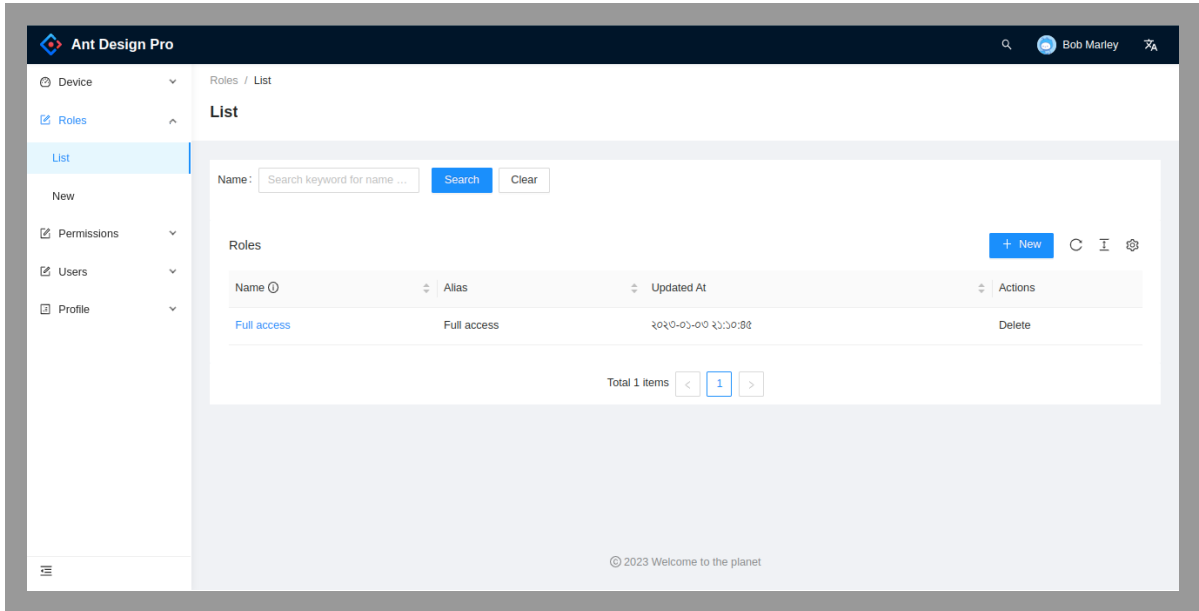

Figure 8.3 Role management page

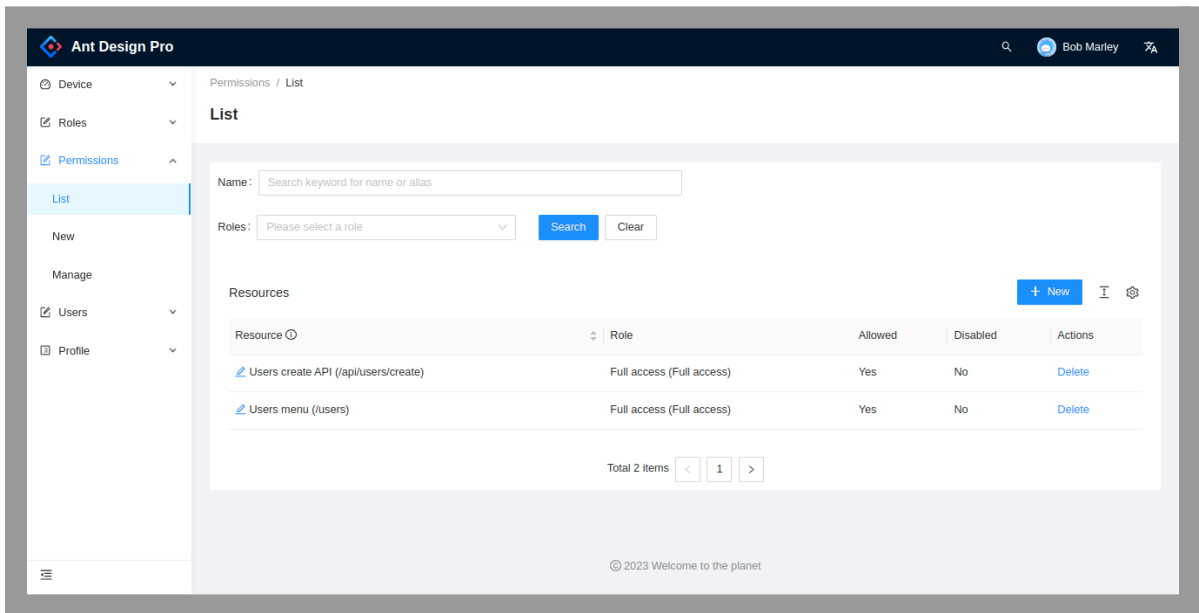

Figure 8.4 Permission management page



## REFERENCES

- [1] "Getting Started with Amazon EC2," Amazon Web Services, available at [https://docs.aws.amazon.com/AWSEC2/latest/UserGuide/EC2\\_GetStarted.html](https://docs.aws.amazon.com/AWSEC2/latest/UserGuide/EC2_GetStarted.html), last accessed on 09-12-2022 at 07:12 PM.
- [2] "Smart Home with Google Assistant & Alexa," IoT Circuit Hub, available at <https://iotcircuitHub.com/smart-home-with-google-assistant-alexa>, last accessed on 07-01-2022 at 10:23 AM.
- [3] "ESP8266 MQTT Home Automation System," Easy Electronics Project, available at <https://easyelectronicproject.com/esp32-projects/esp8266-mqtt-home-automation-system>, last accessed on 07-12-2022 at 07:12 PM.
- [4] "Internet of Things," Wikipedia, available at [https://en.wikipedia.org/wiki/Internet\\_of\\_things](https://en.wikipedia.org/wiki/Internet_of_things), last accessed on 06-23-2022 at 12:12 PM.
- [5] "NodeMCU," available at [https://www.nodemcu.com/index\\_en.html](https://www.nodemcu.com/index_en.html), last accessed on 07-16-2022 at 07:26 PM.
- [6] "MQTT.org," available at <https://mqtt.org>, last accessed on 08-21-2022 at 03:43 AM.
- [7] "Blog," EMQ X, available at <https://www.emqx.com/en/blog>, last accessed on 01-01-2023 at 02:54 PM.
- [8] "Mosquitto," available at <https://mosquitto.org>, last accessed on 12-12-2022 at 03:28 PM.
- [9] "Launch an Instance," Amazon Web Services, available at <https://docs.aws.amazon.com/AWSEC2/latest/UserGuide/ec2-launch-instance-wizard.html>, last accessed on 07-17-2022 at 02:52 PM.
- [10] "ExpressJS," available at <https://expressjs.com>, last accessed on 12-23-2022 at 03:32 PM.
- [11] "ReactJS," available at <https://reactjs.org>, last accessed on 12-22-2022 at 08:20 PM.
- [12] "MongoDB," available at <https://www.mongodb.com>, last accessed on 12-29-2022 at 01:12 AM.
- [13] "MERN Boilerplate," available at <https://github.com/foyzulkarim/mernboilerplate>, last accessed on 09-03-2022 at 05:54 PM.
- [14] "YouTube video," available at <https://youtu.be/VEJ5LVK6scA>, last accessed on 01-02-2023 at 08:33 PM.
- [15] "Arduino," available at <https://www.arduino.cc>, last accessed on 08-21-2022 at 4:25 PM.
- [16] "Low-Cost Smartphone-Controlled Remote Sensing IoT Robot," ResearchGate, available at [https://www.researchgate.net/publication/353005391\\_Low-Cost\\_Smartphone-Controlled\\_Remote\\_Sensing\\_IoT\\_Robot](https://www.researchgate.net/publication/353005391_Low-Cost_Smartphone-Controlled_Remote_Sensing_IoT_Robot), last accessed on 01-03-2023 at 23:40 PM.

# Final Test

---

## ORIGINALITY REPORT

---

19%

SIMILARITY INDEX

16%

INTERNET SOURCES

3%

PUBLICATIONS

13%

STUDENT PAPERS

---

## PRIMARY SOURCES

---

1	<a href="https://dspace.daffodilvarsity.edu.bd:8080">dspace.daffodilvarsity.edu.bd:8080</a> Internet Source	6%
2	Submitted to Daffodil International University Student Paper	5%
3	<a href="https://mosquitto.org">mosquitto.org</a> Internet Source	1%
4	<a href="https://enou.co">enou.co</a> Internet Source	1%
5	<a href="https://www.startupbooted.com">www.startupbooted.com</a> Internet Source	<1%
6	Submitted to Visvesvaraya Technological University, Belagavi Student Paper	<1%
7	Submitted to B.V. B College of Engineering and Technology, Hubli Student Paper	<1%
8	<a href="https://store.roboticsbd.com">store.roboticsbd.com</a> Internet Source	<1%
9	Submitted to Southampton Solent University	