

# **Solar Powered LED Street Light with Auto Intensity Control**

**A Project and Thesis submitted in partial fulfillment of the requirements for the Award of Degree of Bachelor of Science in Electrical and Electronic Engineering**

**Submitted By**  
**Name: Arif Hossain Joy**  
**ID: 182-33-4616**

**Supervised by**  
**Ms. Tanjum Rahi Akanto**  
**Lecturer**  
**Faculty of Engineering**  
**Department of Electrical and Electronics Engineering**



**DEPARTMENT OF ELECTRICAL AND ELECTRONIC ENGINEERING**  
**FACULTY OF ENGINEERING**  
**DAFFODIL INTERNATIONAL UNIVERSITY**

**Dec 2022**

# DECLARATION

I hereby declare that this project “**Solar Powered LED Street Light with Auto Intensity Control**” represents my own work which has been done in the laboratories of the Department of Electrical and Electronic Engineering under the Faculty of Engineering of Daffodil International University in partial fulfillment of the requirements for the degree of Bachelor of Science in Electrical and Electronic Engineering, and has not been previously included in a thesis or dissertation submitted to this or any other institution for a degree, diploma or other qualifications. I have attempted to identify all the risks related to this research that may arise in conducting this research, obtained the relevant ethical and/or safety approval (where applicable), and acknowledged my obligations and the rights of the participants.

## **Signature of the candidates**

Arif Hossain Joy

---

**Name: Arif Hossain Joy**  
**ID: 182-33-4616**

# APPROVAL

The project and thesis entitled “**Solar Powered LED Street Light with Auto Intensity Control,**” submitted by Name: Arif Hossain Joy, ID No: 182-33-4616, Session: Fall 2021 has been accepted as satisfactory in partial fulfillment of the requirements for the degree of **Bachelor of Science in Electrical and Electronic Engineering** on Dec 2022.

Signed

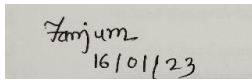

Tanjum  
16/01/23

Ms. Tanjum Rahi Akanto

Department of Electrical and Electronic Engineering

Faculty of Engineering

Daffodil International University.

**Dedicated to**  
**Our Parents**

# CONTENTS

<b>List of Figures</b>		<b>VIII</b>
<b>List of Tables</b>		<b>IX</b>
<b>List of Abbreviations</b>		<b>X</b>
<b>Acknowledgment</b>		<b>XI</b>
<b>Abstract</b>		<b>XII</b>
<b>Chapter 1: INTRODUCTION</b>		<b>1-3</b>
1.1	Introduction	1
1.2	Problem Statement	1
1.3	Objectives	2
1.4	Research Methodology	2
1.5	Gantt Chart	2
1.6	Project Outline	3
<b>Chapter 2: LITERATURE REVIEWS</b>		<b>4-8</b>
2.1	Introduction	4
2.2	Related Research Survey	4
2.3	Compare and Contrast	4
2.3.1	No Warm up Necessary	4
2.3.2	Saves Your City Money	5
2.3.3	Long Lifespan	5
2.3.4	Lower Crime Rates	6
2.3.5	Shuttle Systems	6
2.3.6	Traditional Street Lighting	6
2.3.7	Solar Street Lighting	7
2.3.8	Types of Solar Power Systems	7

2.3.9	Solar Photovoltaic Array (PV) Units	7
2.3.10	Hybrid Solar	8
2.4	Summary	8
<b>Chapter 3:</b>	<b>ANALYSIS OF THE SYSTEM COMPONENT</b>	<b>9-27</b>
3.1	Introduction	9
3.2	Components	9
3.2.1	Arduino Uno	10
3.2.1.a	How to use Arduino Board	10
3.2.1.b	Arduino Uno to ATmega328 Pin Mapping	11
3.2.1.c	Pin Description	12
3.2.2	Servo Motor SG-90	13
3.2.2.a	Wire Configuration	13
3.2.3	LDR (Light Dependent Resistor)	14
3.2.3.a	LDR Symbol	14
3.2.3.b	LDR structure	15
3.2.3.c	LDR Applications	15
3.2.4	INA219 Current Sensor	16
3.2.4.a	INA219 Current Sensor Connection	16
3.2.5	OLED Display Module	17
3.2.5.a	Power Supply Requirement	18
3.2.5.b	OLED Display Module Pinout	18
3.2.6	Solar Panel 6v	18
3.2.6.a	Specifications	19
3.2.7	LED	19
3.2.8	lithium ion 3.7 V Rechargeable Battery	19
3.2.9	Jumper Wire	19
3.2.10	Bread Board	20
3.2.11	Tools Needed	21
3.2.12	PVC Board	21

3.3	Design Specifications. Standards and Constraints	22
3.3.1	Arduino and LDR Sensor Interface	22
3.3.2	Arduino and Servo Motor Connection	22
3.3.3	Block Diagram	23
3.4	Design Analysis	23
5.4.1	Our Project Overview	25
3.4.2	Project flowchart	26
3.4.3	Solar Powered Led Street Light Algorithm	26
3.4.4	INA219 Current Sensor Data	26
3.5	Simulation Setup	27
3.5.1	Hardware Connection	27
3.6	Summary	27
<b>Chapter 4:</b>	<b>RESULTS AND DISCUSSIONS</b>	<b>28-29</b>
4.1	Introduction	28
4.2	Results	28
4.3	Summary	29
<b>Chapter 5:</b>	<b>PROJECT MANAGEMENT</b>	<b>30-31</b>
5.1	Our Project Task	30
5.2	Lesson Learned	30
5.3	Cost of the Project	31
<b>Chapter 6:</b>	<b>IMPACT ASSESSMENT OF THE PROJECT</b>	<b>31-33</b>
6.1	Economical, Societal and Global Impact	32
6.1.1	Impact of engineering solution in economic context	32
6.1.2	Impact of engineering solution in environmental context	32
6.2	Ethical Issues	32
6.3	Utilization of Existing Standards	32
6.4	Other Concerns	33
<b>Chapter 7:</b>	<b>CONCLUSIONS</b>	<b>34-35</b>
7.1	Conclusion	34
7.2	Advantages	35
7.3	Disadvantages	35
7.4	Future Scopes of the Work	35

**References**

**36-37**

**Appendix**

**38-42**

## **LIST OF FIGURES**

<b>Figure</b>	<b>Figure Caption</b>	<b>Page</b>
2.1	History of Street Lights	6
2.2	Solar Glitter (MEPV)	7
2.3	Solar Photovoltaic Array (PV) Units	7
3.1	Front side of Arduino UNO	10
3.2	Arduino Uno to ATmega328 Pin Mapping	11
3.3	Servo Motor SG-90	13
3.4	LDR	14
3.5	LDR Symbol	15
3.6	Photo resistor structure	15
3.7	INA219 Current Sensor	16
3.8	INA219 Current Sensor Connection	17
3.9	OLED Display Module	17
3.10	Solar Panel 6v	18
3.11	LED	19
3.12	lithium ion Battery	19
3.13	Jumper Wire	20
3.14	Bread Board	20
3.15	Tools Needed	21
3.16	PVC Board	21
4.1	Arduino and LDR Sensor Interface	22
4.2	Arduino and Servo Motor Connection	23
4.3	Block Diagram	23
4.4	Circuit Diagram	24
4.5	Our Project Output	25
4.6	Project Flowchart	26
4.7	INA219 Current Sensor Output Data	27



# LIST OF TABLES

<b>Table</b>	<b>Table Caption</b>	<b>Page</b>
Table 3.1	Pin configuration table of Arduino Uno	12
Table 3.2	Wire configuration table of Servo Motor SG-90	13
Table 5.1	Power readings for a bright sunny day, 13th Jun 2021	30
Table 5.2	Cost of the Project	31

# List of Abbreviations

- LCD: Liquid Cristal Display
- AGV: Automated Guided Vehicle
- LED: Light Emitting Diode
- GND: Ground
- VCC: Voltage Common Collector
- AC: Alternating current
- DC: Direct Current
- PVC: Polyvinyl chloride
- B: Battery
- IC: Integrated circuit
- R: resistor

# ACKNOWLEDGEMENT

First of all, we express our heartfelt appreciation to Almighty Allah, without whom we would not have been able to complete this project report. Then we'd want to use this occasion to convey our gratitude and appreciation to our project manager. **Ms. Tanjum Rahi Akanto, Lecturer, Department of Electrical and Electronic Engineering, Faculty of Engineering, Daffodil International University** for your unwavering commitment to assisting, inspiring, and leading us through this endeavor. Without her helpful guidance and assistance, this job would be impossible to complete. Thank you also for providing us the opportunity to select this project.

Apart from that, we'd want to express our gratitude to all of our friends for sharing their experience and information with us and assisting us in completing this project. Thank you also for letting us borrow certain tools and equipment.

We want to express our heartfelt thanks to our loving family for their unwavering support, as well as their inspiration and encouragement throughout our time at this university.

# ABSTRACT

All varieties of street lighting use a lot of energy and are essential for ensuring public safety. In order to ensure public safety, keep street lights on and at the right degree of illumination for both pedestrian and vehicular traffic. This will also make energy conservation simpler and more effective. For businesses in charge of street lighting, operational dependability, or maintenance expenditures, any energy use savings therefore pay off handsomely. This project's main goal is to use an Arduino board to regulate the brightness of street lights. As the night goes on, traffic gradually reduces. This project's main goal is to use an Arduino board to regulate the brightness of street lights. As the night goes on, traffic gradually reduces, Traditional HID lights are being replaced with white light emitting diodes in street lighting systems that can be dimmed (LED). Because of their high longevity and minimal energy use, LED lights are the lighting of the future. Due to the ability to change intensity using pulse width modulation, LED lights are swiftly replacing conventional lights. An Arduino board and a rectified power supply are used in this setup. A MOSFET device is used to link a string of LEDs to the Arduino board. To alter the LED light's intensity, one can alter the duty cycle of a DC source. The PWM method is used to give varied intensities at various times of the night using an Arduino board that has been configured. The LDR in this project also enables it to appropriately track the changeover process.

# CHAPTER 1

## INTRODUCTION

### 1.1 Introduction

The majority of individuals worldwide need energy to do their daily chores due to the rapid growth of technology. Many natural energy sources are being used rapidly in today's civilization. One of these is solar energy, which uses sun trackers and solar panels. Solar panels are structures created to convert solar energy into a source of power. The dual-axis approach to solar tracking could offer 40% more power than a single-axis solar tracker. The dual-axis tracking system extracts the maximum energy from the solar panels due to its flexibility to move into different positions and follow the Sunlight both vertically and horizontally independent of the Sun's location in the sky. A dual-axis tracking device may position itself to face the Sun, as opposed to a single-axis solar tracker. A servo motor may be used to follow the sun precisely, and LDR resistors can be used to determine the intensity of the sun's light, according to the study. A novel mechanical framework for solar trackers was created using two servo motors that can freely rotate on the X and Y axes. A pre-programmed Arduino, which employs the C programming language to give a simple programming way, intelligently controlled the rotation. The created method was based on a Pyrometer, an ultraviolet-sensitive instrument, which measured the intensity of solar radiation.

### 1.2 Problem Statement

- The biggest drawback of manual street light controls is that they waste a lot of energy because they can't all be shut off at once in the morning and take a long time to turn on at night.
- Another wasteful practice is turning on the lights at midnight, even if there is no traffic. Therefore, a system that corrects the shortcomings of the present systems

is required. a system that decreases the need for manual intervention and promotes energy efficiency Low-power, dependable, and efficient components can be used to achieve this.

### 1.3 Objectives

- using solar energy and other renewable energy sources to satisfy rising energy demands
- We must practice energy conservation since our nation is experiencing an energy crisis.
- to lower the cost of the power used.
- We want our product to be more dependable, consume less energy, and last longer.
- To make the roadways more visible in rural regions where power outages are frequent.
- to create a prosperous, intelligent, and digital Bangladesh.
- To lessen the amount of crime that happens at night.

### 1.4 Research methodology

- Research on LED street lights' auto-intensity control principle.
- The circuit's performance and design.
- Learn about the solar system.
- Maintain your solar energy education.

### 1.5 Gantt Chart



Figure. 1.1 Gantt Chart LED street lights

A thorough project plan was then created in the form of a Gantt chart. The chart provided an estimate of the time needed to complete each task as well as a breakdown of the individual tasks needed to finish this project. You may see the Gantt chart. Meetings were held multiple times a week to present deliverables and discuss developments. To ensure that the intended goals would be reached, the Gantt chart was periodically evaluated.

## **1.6 Project Outline**

### **Chapter 1: Introduction**

This chapter discusses the research methodology, project goals, and applications.

### **Chapter 2: Analysis of the system components of the project**

This chapter covered the tools that were utilized for the project. Discuss each component's unique characteristics as well.

### **Chapter 3: Describes all the Hardware Development parts**

Project flowcharts and explanations of hardware connections are the main topics of this chapter.

### **Chapter 4: Discussion**

The project's final output and the project's test results are both included in this chapter.

### **Chapter 5: Conclusion and Future Scope**

We discussed the results and how they may be enhanced going forward.

# CHAPTER 2

## LITERATURE REVIEW

### 2.1 Introduction

Because expensive but necessary street lighting is needed, it is desirable to optimize the system. The manual operation of the traffic lights requires a lot of time and effort. Energy conservation is crucial; switch off the light when not in use instead of leaving it on. [4] One of the most energy-consuming aspects of every city is "Street Light". Almost always, street lights are turned on even after the sun has set, wasting a lot of power. With the use of automated computer equipment that switches the street lights on and off at regular intervals or when the ambient light level drops below a predetermined intensity, we are preventing the issue in this location. When a car pulls up late at night, the street becomes deeper. The street light is either switched off or its intensity is reduced if there is no car. A light detection resistor (LDR) is a device that senses ambient light in each controller. Whenever the ambient light falls below a certain threshold, the lights will turn on. When a car pulls up late at night, the street becomes deeper. The roadway is shut off or the intensity is lowered if there are no vehicles on the road. A light detection resistor (LDR) is a device that senses ambient light in each controller. Whenever the ambient light falls below a certain threshold, the lights will turn on. [5]

### 2.2 Related Research Survey

A device that uses the photovoltaic effect to transform light energy into electrical energy is a photovoltaic smartphone. Solar cells are the fundamental components that make up photovoltaic modules, usually referred to as solar panels. A solar tracking module's surface tracks the sun's activity throughout the day. [1] A solar tracker may increase a solar-powered equipment's efficiency at any fixed position, and a solar-powered gadget should be put as close to the sun as feasible. Position. Considerations should be made for performance, cost, and degree of sophistication. The heliostat, which is a mobile replica



that replicates the sun's position to a fixed place, is a common form of tracker. The software establishes a solar tracker's accuracy. Concentrators, particularly those used in photovoltaic smartphone applications, need to be extremely precise in order to deliver the focused sunlight precisely to the powered device, which is situated close to the reflector or lens' focal point. Because concentrator structures must be monitored in order to function, single-axis monitoring is crucial[2]. Less accuracy is required for non-concentrating applications, and many of them may function without being monitored. On the other side, high-impact monitoring can increase a device's overall output power as well as the amount generated during peak demand hours [3].

## **2.3 Compare and Contrast**

LED street lighting has discovered a solution to simultaneously keep drivers of cars attentive, pedestrians secure, and city energy expenses cheap. In the infographic below, learn more about four of the most significant benefits of LED street lighting. [6]

### **2.3.1 No Warm up Necessary**

It is impossible to stress how crucial street lighting is for safety. However, incandescent or fluorescent lights may take too long to warm up before turning on when the temperature drops. Since heat destroys LED bulbs, cool temperatures are ideal for their growth. When installing LED street lights, there is no need to wait for the bulbs to warm up. They always come on right away.

### **2.3.2 Saves Your City Money**

Street lighting carries a hefty price tag. Many cities have shifted to LED lighting as a method to save money while also helping the environment as more green energy is used and carbon footprints are reduced. Although regular avenue lighting is initially more expensive, the city will ultimately save enough energy to pay for the lights! Additionally, as LED lighting grows in popularity year after year, prices drop down to meet the demand! According to LED Luxor, the price of building LED streetlights has decreased by as much as 50% over the past two years.

### **2.3.3 Long Lifespan**

Burned-out street lights are a nuisance when you're out at night, either driving or strolling. Bright illumination aids in maintaining our focus and vigilance. The long lifespan of LED street lighting means that your community won't need to worry about replacing broken bulbs. Although LED street lights are more expensive than traditional ones, they use less energy and require less upkeep.

### **2.3.4 Lower Crime Rates**

Recent studies in Los Angeles show that crime rates have decreased as a result of the installation of brilliant, white LED street lighting. Late at night, when there are fewer dark, unlit places than while walking under standard street lights, people feel safer returning home.

### **2.3.5 Street Lighting**

Since the beginning of human coexistence, there has been street lighting. Ancient Romans used oil lamps filled with vegetable oil in front of their dwellings as early as 500 BC. William Murdock lit a gas light in 1802 using coal gas. In 1807, the city of London, England, determined that gas lights would be used to illuminate the whole street in place of lamps in front of houses. However, it wasn't until 1816 that this form of gas light was used in the United States. Baltimore, Maryland was the first city in the US to adopt gas lights. Gas lighting was upgraded, and less-intense electric lighting was installed in their stead. [7]



Figure. 2.1 History of Street Lights

### **2.3.6 Traditional Street Lighting**

Traditional street lighting has been in use for a long time. People utilize the elevated source of light on the side of a road or path to see at night. Traditional street lights are connected to the electrical grid, and their monthly power usage is billed. The energy efficiency of LED light bulbs has recently increased, and several communities have switched to LED street lighting to save money.

### **2.3.7 Solar Street Lighting**

In contrast to conventional street lighting, solar street lighting is a relatively new technology. A photovoltaic panel on the solar light will produce its own power from the sun, which it will then store in a battery until it is enough dark for the light to switch on. Numerous off-grid uses for solar illumination are possible. There are two possible ways to connect the solar panels: either through a micro grid, which is simply a miniature power grid reserved for the street lights, or separately for each street light.

### **2.3.8 Types of Solar Power Systems**

Solar photovoltaic systems and Microsystems Enabled Photovoltaics (MEPV) will be discussed for research purposes. Solar photovoltaic systems are the most prevalent and classic solar power technology. MEPVs are a very new and little utilized class of vehicle. To further comprehend these systems and their uses, two systems will be explored. [8]



Figure. 2.2Solar Glitter (MEPV)

### **2.3.9 Solar Photovoltaic Array (PV) Units**

Due to their small size, solar cells may adapt to the shapes and contours of the object they are powering, merging their minuscule PV into its appearance, feel, and usability. There are three various micro PV cell designs to select from, and these cells can be flexible, molded, or flat plated.

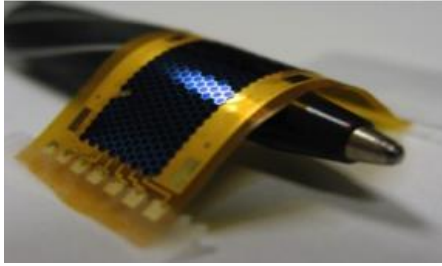

Solar Photovoltaic Array (PV) Units (Figure 2.3).

It is utilized to power electrical equipment or to transmit electricity via electrical circuits from the grid to the grid. Today, crystalline silicon or thin-film solar cells make up the bulk of solar cells. material composed of semiconductors Even though silicon is expensive, studies have proven that it effectively turns sunlight into energy. Thin-film materials are occasionally utilized because they are less costly. The drawback is that these materials need more surface area to produce energy and are less effective than silicon in doing so. Micro PV flexible sheets are similar to the many small PV cells that make up a solar panel.

### **2.3.10 Hybrid Solar**

The two aforementioned types of solar systems are combined in a hybrid solar system. There is a grid-supplied electrical supply as well as the capacity to store and save energy. Although it is less expensive than an off-grid solar system, it does not require diesel backup. a hybrid solar system. The cost of an off-grid solar system is higher, though. The existence of batteries and a battery inverter is the only distinction between conventional on-grid solar and hybrid solar. Batteries are charged using solar energy that isn't being used for other things. Customers may create a system that satisfies their own requirements and preferences because solar energy is adaptable and modular in nature. Various household duties can be completed or partially completed with solar energy. Solar photovoltaic panels, which may be used with the aforementioned kinds of solar systems, efficiently convert heat from sunlight into energy. [9]

## **2.4 Summary**

This chapter examined a review of the literature on solar-powered LED street lights with automatic intensity control. The advantages of street lighting and various types of solar power systems.

# CHAPTER-3

## ANALYSIS OF THE SYSTEM COMPONENT

### 3.1 Introduction

The idea is to power LED-based street lighting with auto-intensity control using solar energy from photovoltaic cells. More people and businesses are choosing solar energy as awareness of it among the general public grows. Sunlight is converted into electricity by photovoltaic panels and used to charge batteries. The charging is controlled by a charge controller circuit, which also guards against the battery being overloaded by the solar panel.

### 3.2 Components

Below is a list of the key elements of a solar-powered LED street light with automatic intensity control.

- i. Arduino Uno
- ii. Servo Motor SG-90
- iii. LDR (Light Dependent Resistor)
- iv. INA219 Current Sensor
- v. OLED DISPLAY (0.96 IN, 128X64, IIC)
- vi. Solar Panel 6v
- vii. Led Blub
- viii. TP4056Charger Module
- ix. 6v Battery
- x. Jumper wire
- xi. Vero board
- xii. PVC Board

### 3.2.1 Arduino Uno

Based on the ATmega328P CPU, the Arduino Uno is a microcontroller board with an 8-bit resolution. The ATmega328P CPU is supported by a voltage regulator, a voltage oscillator, serial communication, and other parts. The Arduino Uno has a USB connection, a Power barrel connector, an ICSP header, six analog input pins, 14 digital input/output pins, a Power barrel connector, and a reset button. [10]

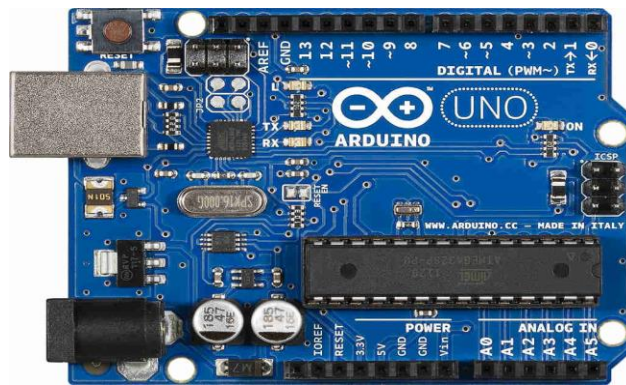

Figure. 3.1 Front side of Arduino UNO

#### 3.2.1.a How to use Arduino Board

- The pin Mode (), digital Read (), and digital Write () functions on the 14 digital input/output pins allow them to be utilized as input or output pins in Arduino programming. There is a 20–50K Ohm pull-up resistor on each pin, which is often left disconnected and runs at 5V. The most current that may be sent or received is 40 mA. Some of the 14 pins' functions are as follows:
- Rx and Tx serial pins: These pins are used to transmit and receive TTL serial data. To link them, an ATmega328P USB to TTL serial chip is utilized.
- External Interrupt Pins 2 and 3: These pins can be configured to initiate an interrupt in response to low values, rising or falling edges, or value changes.
- PWM Ports 3, 5, 6, 9 and 11: When employing the analog Write () technique, these pins provide an 8-bit PWM output.

- For SPI communication, SPI Pins 10 (SS), 11 (MOSI), 12 (MISO), and 13 (SCK) are necessary.
- built-in LED light source A built-in LED attached to pin 13 is activated when pin 13 is HIGH and inactive when pin 13 is LOW.
- In addition to the 14 digital pins, there are six analog input pins, each of which has a resolution of 10 bits, or 1024 distinct values. Although this limit may be increased by utilizing the AREF pin and the analog Reference () function, they only measure between 0 and 5 volts.
- Analog pins 4 (SDA) and 5 (SCL) are also utilized by the Wire library for TWI communication (SCA).
- There are a few extra pins on the Arduino Uno, which are listed below:
- When used in conjunction with the analog Reference () function, AREF: Offers a reference voltage for analog inputs.
- When the reset pin is set to LOW, the microcontroller is reset.

### 3.2.1.b Arduino Uno to ATmega328 Pin Mapping

Below is an illustration of the pin mapping when an ATmega328 chip is used in place of an Arduino Uno.

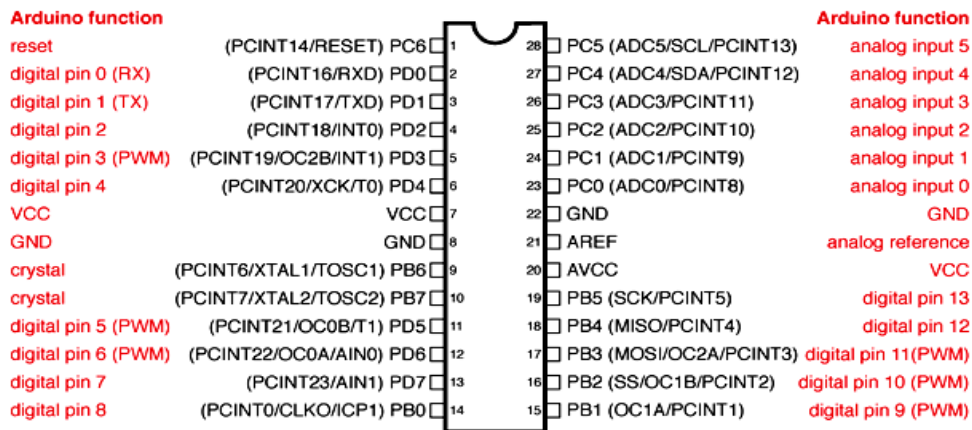

Digital Pins 11, 12 & 13 are used by the ICSP header for MOSI, MISO, SCK connections (Atmega168 pins 17, 18 & 19). Avoid low-impedance loads on these pins when using the ICSP header.

Figure 3.2 Arduino Uno to ATmega328 Pin Mapping

### 3.2.1.C Pin Description

Pin Name	Details
Vin, 3.3V, 5V, GND	<p>Vin: This is the voltage input to Arduino when using an external power source.</p> <p>5V: A regulated power supply provides electricity to the CPU and other board-mounted components.</p> <p>A voltage regulator included within the device creates a 3.3V supply. It has a 50 milliampere maximum current draw capacity.</p> <p>GND: ground-surfaced pins</p>
Reset	There are on/off switches for the microcontroller.
A0 – A5	It provides analog input in the 0 to 5 volt range.
Digital Pins 0 - 13	pins that may function simultaneously as input and output.
0(Rx), 1(Tx)	This gadget can send and receive TTL serial data.
2, 3	to stir up an uproar
3, 5, 6, 9, 11	The 8-bit PWM output option is available.
13	Pressing the power button will turn on the integrated LED.
A4 (SDA), A5 (SCA)	This is the location of TWI discussion.
AREF	to provide a reference voltage for the input voltage.

Table 3.1 Pin configuration table of Arduino Uno



### 3.2.2 Servo Motor SG-90

Servo motors come in a wide range of styles, each with a unique set of characteristics and uses. You may choose the ideal servo motor for your project or system using the information in the following two paragraphs. Since most hobby servo motors can only rotate from 0 to 180 degrees owing to their gear arrangement, make sure your project can withstand the half circle. Most amateur servo motors work at a voltage of 4.8 to 6.5 volts; the greater the voltage, the more torque we can create. If not, a 0° to 360° motor or a motor exchange can be used to create a full circle. Because the gears in the motors are easily worn out, you can use metal gears instead of standard plastic gears if your application calls for stronger and longer-running gears. [11]

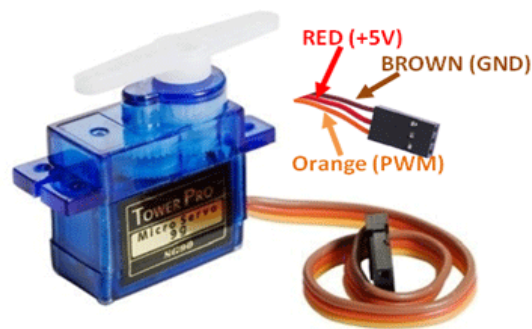

Figure 3.3 Servo Motor SG-90

#### 3.2.2.a Wire Configuration

Wire Colour	Description
Brown	The system's ground is connected to the ground wire.
Red	+5V is often used to power the motor.
Orange	Through this line, a PWM signal is transmitted to run the motor.

Table 3.2 Wire configuration table of Servo Motor SG-90

### 3.2.3 LDR (Light Dependent Resistor)

Electrical circuit designs frequently use LDRs, sometimes referred to as photo resistors or light dependent resistors, to detect the presence or quantity of light. These electrical parts are also referred to as photocells, photoconductors, as well as light dependent resistors (LDRs), photoresists, and photocells. You may also utilize other electrical parts like photodiodes and phototransistors. LDRs, also known as photoresistors, are used in many different types of electrical circuit designs. In response to variations in light intensity, they generate a substantial movement in resistance. LDRs are employed in a variety of applications due to their low cost, ease of manufacture, and simplicity of usage. LDRs are currently employed in many applications that need the sensing of light levels, having formerly been used in photographic light meters. Resistor devices that react to light are commonly accessible. Given the status of the supply chain in the electronics sector, electronic component wholesalers typically provide them, making this the most common way to acquire them. Large and small distributors of electronic components often offer a wide assortment. [12]

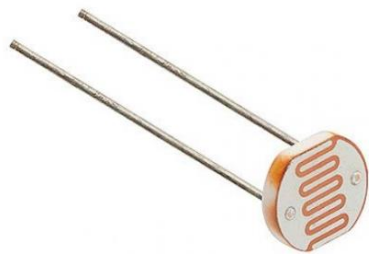

Figure 3.4 LDR

#### 3.2.3.a LDR Symbol

The resistor circuit symbol served as the basis for the LDR sign, which also includes light in the shape of arrows. In electrical circuits, it is employed. It follows the same rules as the photodiode and phototransistor circuit diagrams, which employ arrows to represent light striking these parts.

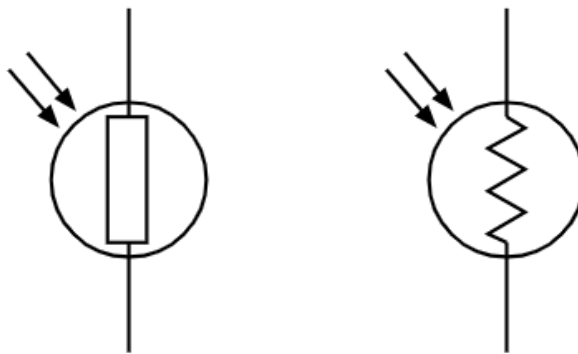

Figure 3.5 LDR Symbol

### 3.2.3.b LDR structure

A photoresistor is a type of light-sensitive resistor having a body that is horizontal and exposed to light. A photoresistor's fundamental structure is as follows:

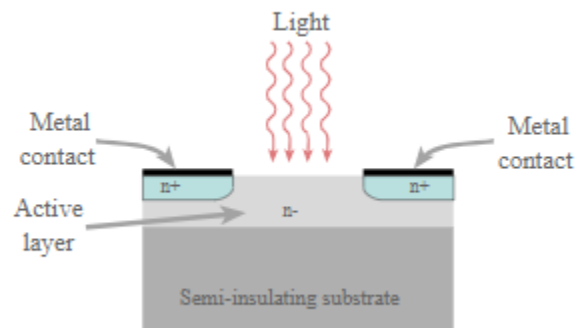

Figure 3.6 Photoresistor structure

### 3.2.3.c LDR Applications

Photoresistors are used in a variety of applications and may be found in electrical circuit designs of all shapes and sizes. They are low-cost, robust, and have a straightforward design. They are utilized in several electrical components and circuits, such as photographic light meters, street lamp illumination controllers, fire and smoke detectors, and burglar alarms. Extrinsic photoresistors can be used as infra-red photodetectors in a variety of electrical circuit designs since they are more sensitive to longer wavelengths. Nuclear radiation can also be detected using photoresistors.

### 3.2.4 INA219 Current Sensor

Your power monitoring issues will be resolved with the INA219B breakout board and the INA219 Feather Wing. Instead of struggling with two multimeters, you may use this breakout to accurately monitor both the high side voltage and DC current drain through I2C.

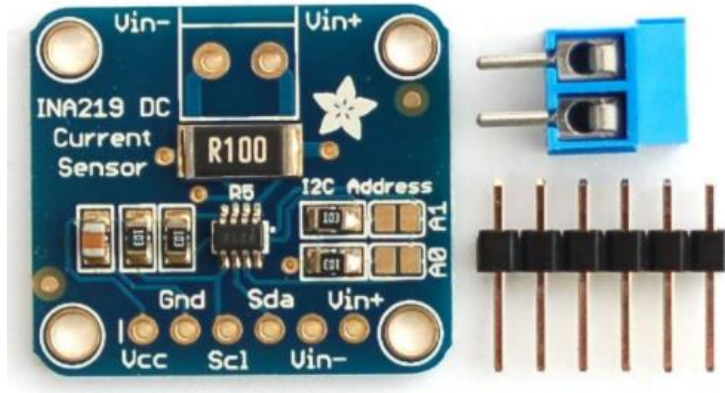

Figure 3.7 INA219 Current Sensor

Most current-measuring devices, like our current panel meter, can only measure current that is on the low side. You must connect the measuring resistor between the target ground and actual ground if you don't want to use a battery. The ground reference will vary as the current varies because the voltage drop across the resistor is proportional to the current flow. Many circuits can be harmed by a moving ground reference. The INA219B chip is far more sophisticated and can handle large side currents of up to +26VDC despite being powered by 3 or 5V. Additionally, it will report the high side voltage, which may be used to monitor the efficiency of solar panels or battery life. [13]

#### 3.2.4.a INA219 Current Sensor Connection

The Arduino's 5V or 3V connection powers the INA219 breakout board, and it interacts with it through I2C. The Arduino's 5V or 3V connection powers the INA219 breakout board, and it interacts with it through I2C. GND must be linked to GND. VCC has to be wired to 5 volts. Connect SDA to SDA for pre-R3 Arduinos next (Analog pin 4). join SCL to SCL as well (Analog pin 5 on preR3 Arduinos)

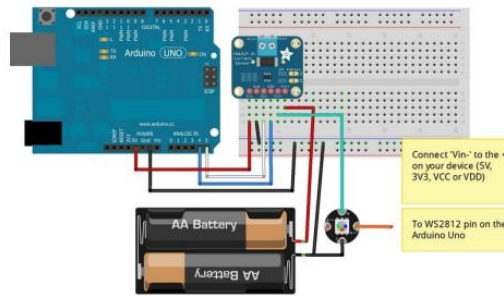

Figure 3.8 INA219 Current Sensor Connection

### 3.2.5 OLED Display Module

The SSD1306 is the module's key component—a powerful single-chip CMOS OLED driver controller. It has a number of ways to interface with the microcontroller, including I2C and SPI. SPI requires additional I/O pins but is often quicker than I2C. I2C, in comparison, just needs two pins and may be used by several I2C peripherals. There is a trade-off to be made between pins and speed. As a result, everything comes down to taste. [14]



Figure 3.9 OLED Display Module

#### 3.2.5.a Power Supply Requirement

OLED displays don't need backlights because they produce their own light. This explains the display's high contrast, broad range of vision, and capability to show deep, black depths. The amount of electricity required to power the OLED is lower because there is no backlight. The display consumes 20mA of electricity on average, however this varies depending on how much of the display is illuminated. The SSD1306 controller can operate between 1.65V and 3.3V. On the other hand, an OLED panel needs a supply voltage of 7 to 15 volts. Internal charge pump circuitry satisfies each of these various

power needs. When connecting it to an Arduino or another 5V logic microcontroller, a logic level converter is no longer necessary.

### 3.2.5.b OLED Display Module Pinout

- GND should be linked to the Arduino's ground.
- The display's power source, VCC, is attached to the Arduino's 5 volts pin.
- SCL is the I2C interface's serial clock pin.
- The I2C interface's SDA pin is used for serial data.

### 3.2.6 Solar Panel 6v

A battery power supply system may be powered by a solar panel with a voltage of 6 volts and a power of 1 watt or a charger with a current of 167 milliamps. This solar panel may be used in any small stationary or transportable installation and is simple to operate. You will be able to use solar energy as a consequence. in the open sun The cell's maximum output is 1 watt with a direct voltage of 6 volts (ie a current of 167mA). To boost voltage and current, more panels can be linked in series or parallel. At a voltage of 6V DC, the Parallax 6V 1W solar panel produces 1W of power (ie 167mA). [15]



Figure 3.10 Solar Panel 6v

#### 3.2.6.a Specifications

Solar Panel, 6V, 1W

Voltage at Output: 6V

Power Output: 1W

### 3.2.7 LED

The lights that flicker are made with LEDs. This is a necessity for power indication, pin status, opto-electronic sensors, and entertaining blinky displays. This LED has a very straightforward design with a 5mm red lens. It has a normal forward voltage of 2.0V and a rated forward current of 20mA. [17]



Figure. 3.11 LED

### 3.2.8 lithium ion 3.7 V Rechargeable Battery



Figure. 3.12 lithium ion Battery

This is a Lithium Ion Cell Battery (18650). While typically seen in lights, these spherical high-capacity cells may also be utilized as a 3.7V drop-in rechargeable battery. For anyone who want a strong cell that is easy to install and replace, this battery is fantastic. If there is an excessive discharge, damage could happen. Both the discharge voltage and the total voltage shouldn't be less than 2.75V. [17]

### 3.2.9 Jumper Wire

A jump wire is a short electrical cable with a solid tip (or no tip at all; it is simply

"tinned") on one end that is used to connect components on a breadboard. Jumper wire comes in a range of forms and diameters depending on the two end points. Male-male relationships can also include male-male, male-female, and so on. In our project, the robot's MCU must first be connected to the sensor before we can link the two together. A jumper wire from male to female was used. Several connections on the bread board were made using a straightforward jumper wire. Below is a picture of a variety of various jumpers. [18]



Figure 3.13 Jumper Wire

### 3.2.10 Bread Board

A white ABS plastic box with conductive metal strips on one side is what is known as a breadboard. On a breadboard, you can see a pattern of several holes both vertically and horizontally. Each line hole is separated by insulation. Each hole in the plastic container is placed differently. Circuit boards using a breadboard layout have been around for a while. There are two divisions in the divestment area (bus divests and socket divests). Bus divests are often utilized to supply power to the circuit. It has two lines: one for the ground line or negative line and one for the positive line. Socket divests house the largest bulk of a circuit's components. It is often divided into two halves, each with an own set of guidelines. This graphic has 64 columns and five rows. [19]

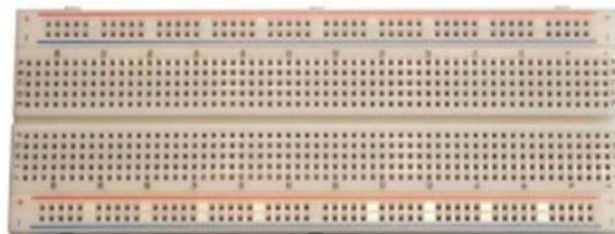

Figure 3.14 Bread Board



### 3.2.11 Tools Needed

The following is a list of some of the tools' names.



Figure 3.15 Necessary Tools

- i. Soldering Iron.
- ii. Glue gun Cutter.
- ii. Knife.
- iv. Digital Multimeter
- v. Screwdriver.
- vi. Tweezer.
- vii. Pana vise.
- viii. Plier with a needle nose.

### 3.2.12 PVC Board

A brand-new kind of ecologically friendly plastic material called PVC foam sheet/board may take the place of steel and wood. It provides a lot of benefits. [20]



Figure 3.16 PVC Board

### 3.3 Design Specifications. Standards and Constraints

#### 3.3.1 Arduino and LDR Sensor Interface

- The illustration demonstrates how to attach an IR sensor to an Arduino.
- All Resistor wire may be linked to +5V in Arduino.
- The LRR one-side wire is connected to ground in Arduino.
- The Arduino's points A3, A2, A1, and A0 are each linked to a single LDR wire.

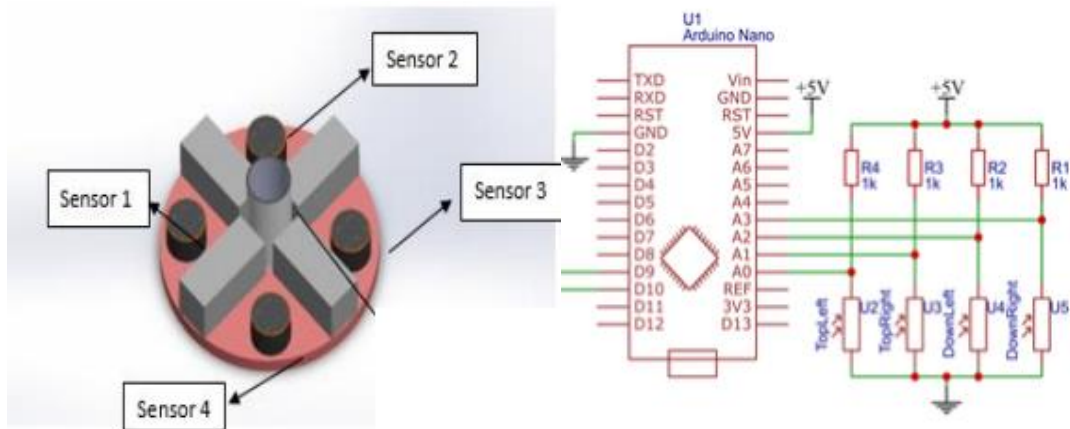

Figure. 3.17 Arduino and LDR Sensor Interface

#### 3.3.2 Arduino and Servo Motor Connection

- The red wire of an Arduino may be connected to +5V, while the green wire can be connected to ground.
- A digital pulse on the yellow wire may be connected to an Arduino digital output.

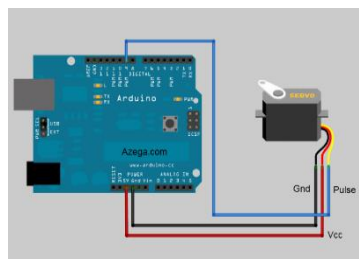

Figure. 3.18 Arduino and Servo Motor Connection

### 3.3.3 Block Diagram

Due to the intense sunshine during the day, the LDR (light dependent resistor) will not function, as indicated in the Block Diagram. On the other side, while the street light won't work, the servo motor will. But at night, the intensity will be less than the resistance of the LDR, leading to a closed circuit. The LDR sensor will provide a signal to the Arduino. The IR sensor will send a signal to the Arduino when the item passes through. The LED will be "HIGH" when the sensor sends its output value to Arduino; it will remain that way until the item passes by, at which point it will change to "LOW."

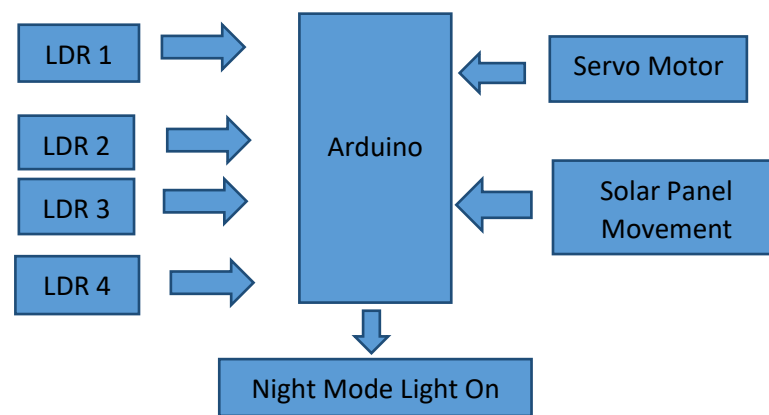

Figure 3.19 Block Diagram

## 3.4 Design Analysis

### 3.4.1 Our Project Overview

The most popular type of light sensor is an LDR sensor. The frame that supports the solar panel has two servo motors mounted. The Arduino program is already loaded into the microcontroller. The project is run in the following manner: The quantity of sunlight that strikes them is detected by LDR. The top, bottom, left, and right LDRs are the four LDRs. The analog readings from the two top LDRs and the two bottom LDRs are compared for east-west tracking, and the vertical servo moves in that direction if the top pair of LDRs detects more light. If the lower LDR detects more light, the servo moves in that direction. The analog readings from two left LDR and two right LDR are compared for the solar panel's angular deflection. The horizontal servo will move to the left if the

left set of the LDR receives more light than the right set. The servo travels in that direction if the right pair of LDR detects more light. Solar energy is converted by the solar cell into electrical energy, which is then saved in the battery. The LDR will automatically switch on the lights when it detects that it is becoming dark.

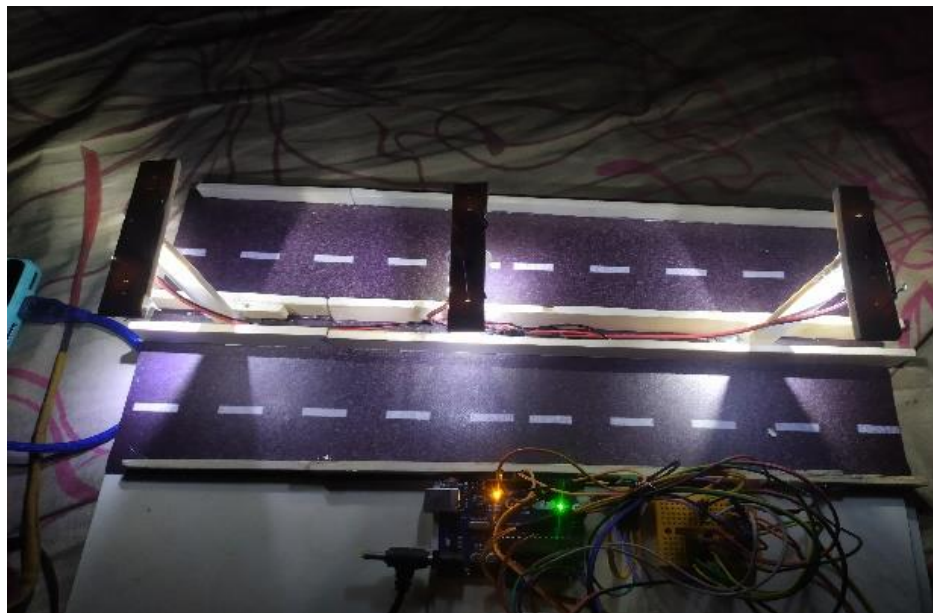
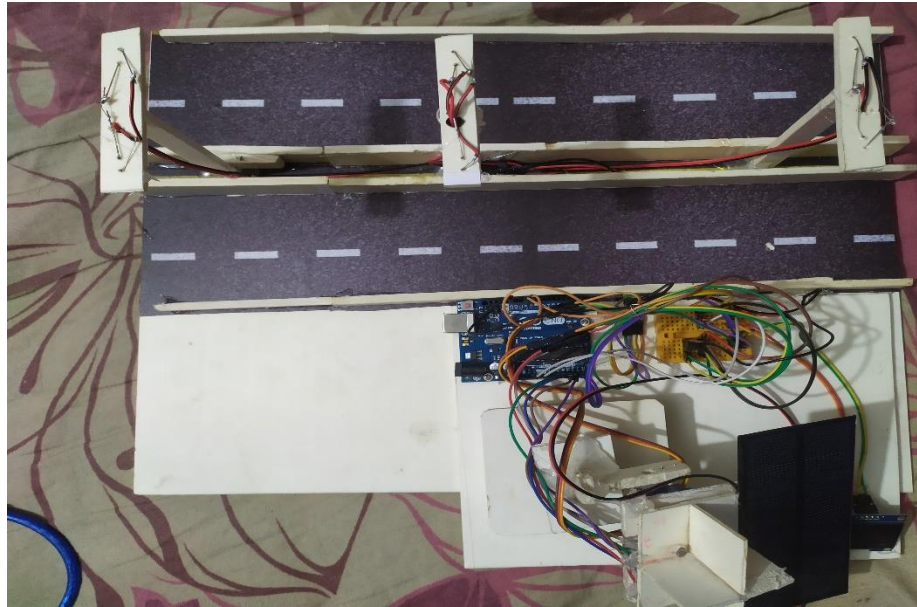

Figure: 3.20 Our project Output

### 3.4.2 Project Flowchart

A sequential process is shown in a flowchart. A flowchart uses a variety of different sorts of blocks arranged sequentially to show the stages in a process or the operation of a computer. Similar to this, the flowchart shows how each of the several sensors used in the project serves its purpose.

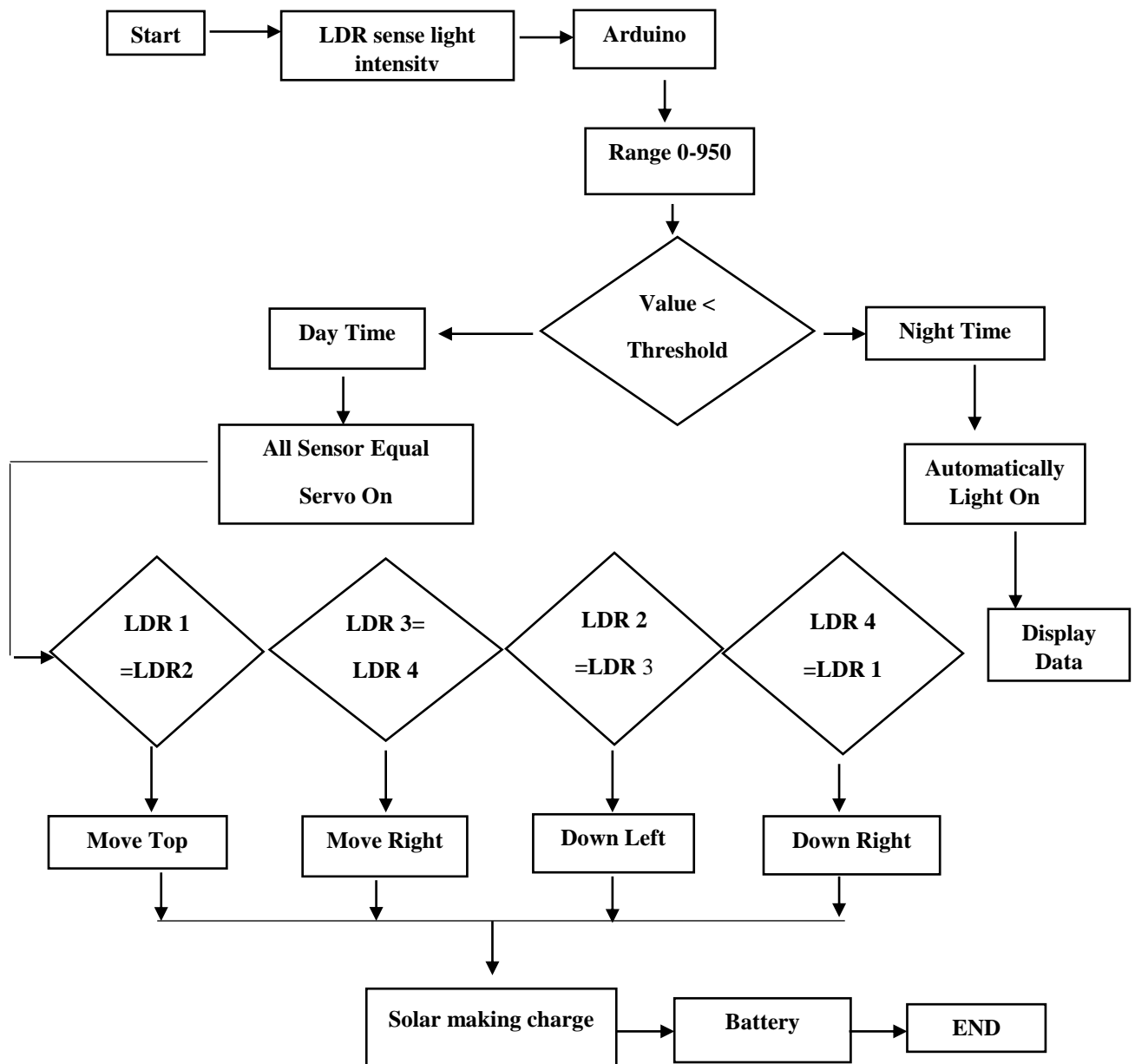

Figure :3.21 Project Flowchart

### 3.4.3 Solar Powered Led street Light Algorithm

Step 1: Start

Step 2: LDR sense light intensity

Step 3: Night Mode =Light on

Step 4: Day Mode= Light Off and Servo Moving and Create Charge

Step 5: End

### 3.4.4 INA219 Current Sensor Data

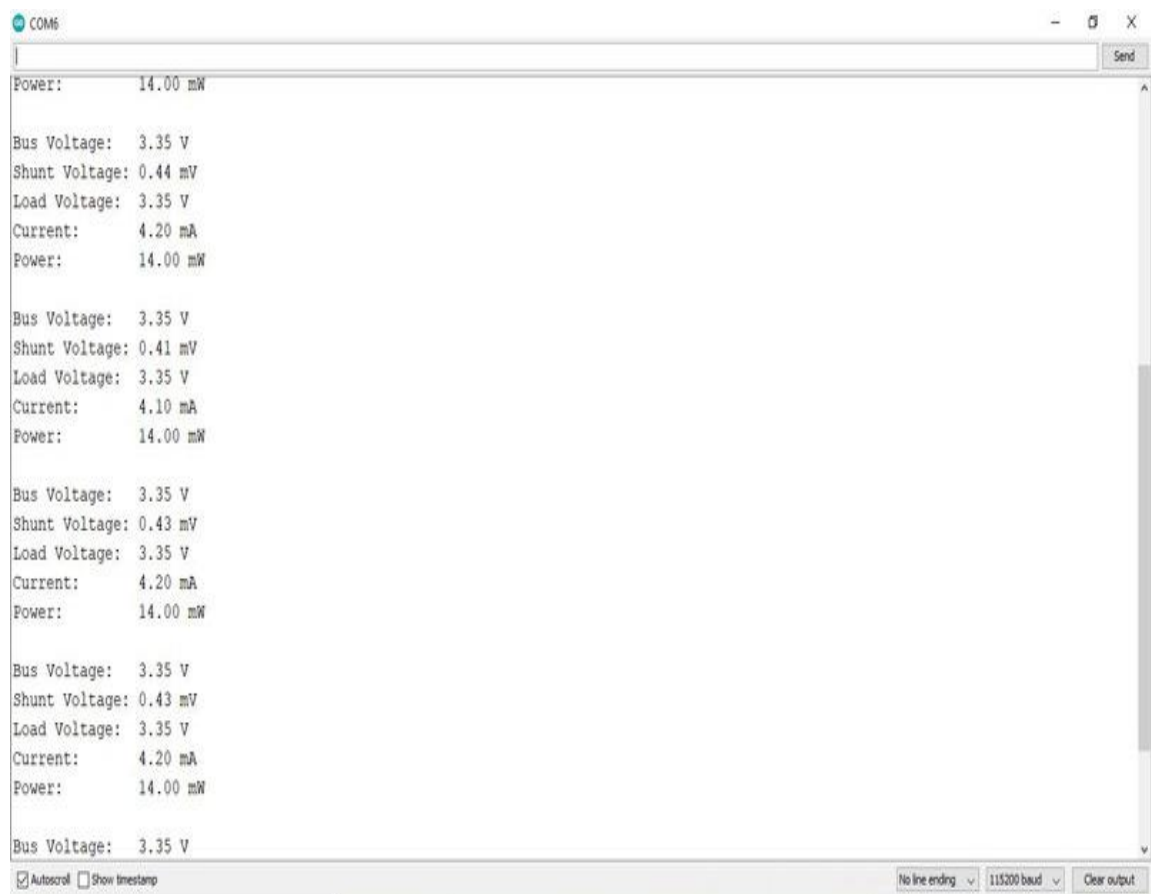

Figure :3.22 INA219 Current Sensor Output Data

## 3.5 Simulation Setup

### 3.5.1 Hardware Connection

Software called Fritzing was used to model the solar panel tracking system. To determine if the system we designed and constructed would live up to our expectations, we performed a simulation. The system's whole circuit architecture and connections are made visible by the simulation approach. Figure 4.4 displays the simulation's results, which were exactly what we predicted. Then, using experimental observation between fixed and implemented tracking solar panels, the performance gains of the implemented tracking solar panels and the fixed solar panels were compared. The same brand and kind of 6W solar panel were employed.

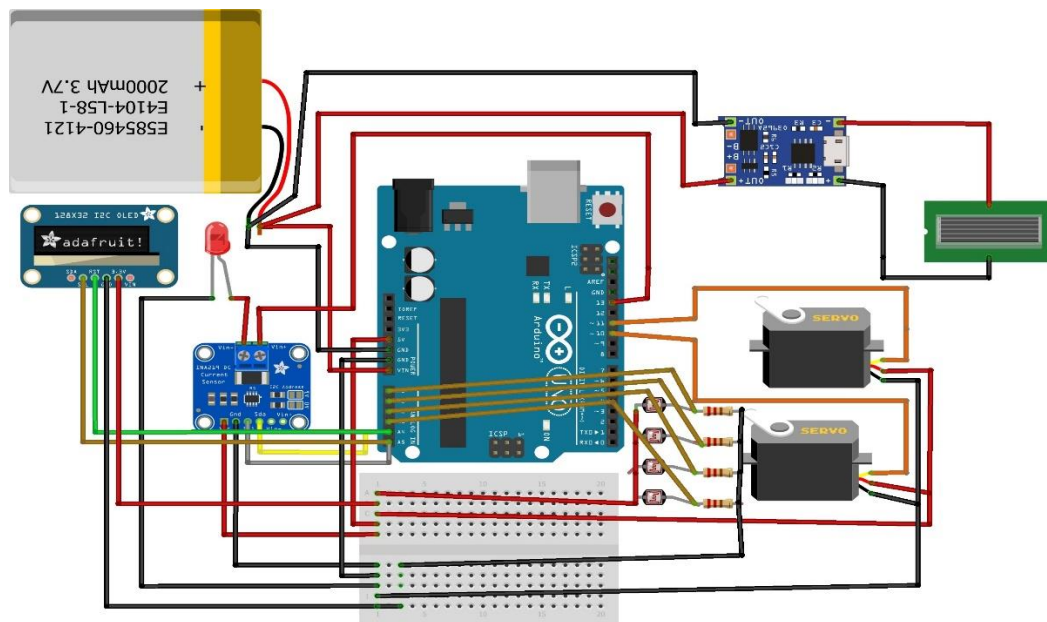

Figure:3.23 CircuitDiagram

## 3.6 Summary

The equipment used in the Solar Powered LED Street Light with Auto Intensity Control is covered in this chapter. The desktop, like the other challenge-related equipment, must be in good working condition. We'll try to explain the nuances of each person's hardware work in this part.

# CHAPTER 4

## RESULTS AND DISCUSSIONS

### 4.1 Introduction

The two components of our project are solar tracking and automated street light control. Based on the amount of ambient light, the automatic road light regulation system controls streetlights. You can follow the sun with the help of the Solar Tracking System. Tracking systems with dual axes produce the greatest power from solar panels because they can switch positions and see the Sun's light both vertically and horizontally regardless of the Sun's location in the sky. Tracking systems have several axes, in contrast to single-axis solar trackers. They have two axes that they may use to alter their position in order to face the Sun's light. The circuit for the automated streetlight management system is made up of an Arduino Uno, six road lights, four LDRs, and two servos. Four LDRs are linked to each of the six leds. The streetlight is equipped with two bulbs: one situated on top to assess the energy of the environment, and the other within to assess the lamp's health.

### 4.2 Results

The prospect of creating a new street lighting system that uses less energy while providing ample illumination captivates every engineer working in this sector. The system uses light sensors that are put in the street light circuit to automatically turn on and off the lights. Automatically, street lights are switched off during the day and on at night. Sensors in the system alert the microcontroller when a problem arises, and the microcontroller then communicates this information to the control station through the circuit's power line. The control station can make judgments based on this information. It will take less time to identify and fix each individual light since the expert will be able to discover it quickly. The major objective of the suggested approach is to resolve individual issues in less working hours as opposed to more time. The microcontroller receives the data from the LDRs and processes it before transmitting it to the control



station in order to determine the light's condition. Each street lamp's condition and functioning will be monitored by the control station.

Table 5.1: Power readings for a bright sunny day, 25th Oct 2022

Time	Solar panel with a set power reading (6W)	The installed tracking solar panel system's power reading (6W)
7.25	0.482	1.489
8.35	1.064	2.806
9.35	1.678	3.207
10.35	1.206	3.891
11.35	3.236	4.142
12.35	3.208	4.804
1.35	4.991	4.991
2.35	4.994	4.989
3.35	4.997	4.974
4.35	3.878	4.948
5.35	3.827	4.878
6.35	2.638	3.967

### 4.3 Summary

Once all of the elements in this chapter have been finished, the Solar Powered LED Street Light with Auto Intensity Control will be functional. The most challenging part of this chapter was creating an algorithm for the functioning behavior of the Project. As a result, this chapter's main objective was to help the reader understand the algorithm and the connection diagram.

# CHAPTER 5

## PROJECT MANAGEMENT

### 5.1 Our Project Task

As per our motive, the idea of this paper is to create such innovation for our current street light system so that the power consumption can be saved. As presented in Fig. 8, when there are no vehicles on the road at night-time, still the dim light continuously glows, and it wastes energy. So, we enhanced our task with the switching of the street lights based on the IR Obstacle detection sensor. In which when the object is detected at night then the LEDs will switch ON automatically, otherwise the lights will remain OFF. This task is implemented on another board and the circuit design can be seen in Fig. 3.4. In addition, our main goal was to extract maximum power from the lathe, so we Developed Dual-Axis LDR Technology.

### 5.2 Our Project Lesson Learned

The same system is further extended to design a second mode that turns the streetlights ON, based on only object's detection. Meanwhile, it is presented that the proposed automated systems have capabilities to control the status of doors (closed/opened) and monitor objects. The hardware implementations of the proposed systems were carried out at a lab-scale prototype to verify the simplicity, flexibility, reliability, specificity and low cost of the system. As a lesson learned, we found that the proposed systems can be easily tested under real conditions at large-scale in near future, and it can be easily implemented in smart cities, home automation, agriculture field monitoring, timely automated lights, parking lights of hospitals, malls, airport, universities, and industries, etc.

### 5.3 Cost of the Project

Sr. No.	Particulars	Cost in TK
01	Arduino Board Uno	1100
02	2psc Servo Motor	500
03	Bread bode	250
04	Resistor	50
05	OLED Display	450
06	LDR 4 psc	50
07	Connecting wire 2set	180
08	Battery	400
09	PVC wood board	400
10	Solar Panel	300
11	glue	50
	TOTAL	3730

Table 5.2: Cost of the Project

# CHAPTER 6

## IMPACT ASSESSMENT

### OF THE PROJECT

#### **6.1 Economical, Societal and Global Impact**

##### **6.1.1 Impact of engineering solution in economic context**

We have always kept the project completion budget in mind throughout the entire process. We were successful in creating a project that is reasonably priced and whose fair performance justifies the cost of the product. As a result, we can conclude that the project is cost-effective.

##### **6.1.2 Impact of engineering solution in environmental context**

We have used energy that is harvested from the sun in our project because it is the most practical source of energy. The solar panel receives a tremendous quantity of heat from the sun and transforms it into electrical energy. Because we use renewable energy, there is no pollution and it is very environmentally beneficial.

#### **6.2 Ethical Issues**

Products like new generation lithium-ion battery energy storage systems (like the Tesla Powerwall) utilize materials like lithium, cobalt, and tin in the alternative energy and electronics industries. Critics draw attention to moral concerns about the use of these materials and their potential connections to war, human rights violations, subpar labor practices, negative environmental effects, and supply-chain security difficulties.

#### **6.3 Utilization of Existing Standards**

This circuit is made up of a solar panel-powered battery charge controller circuit. The microcontroller, which is set up to operate as a PWM and is coupled to an LDR that outputs high/low signals based on light intensity, receives power from the battery. The

LED is OFF when the microprocessor sends a strong signal to the mosfet. When the MOSFET detects a low signal, it turns ON, illuminating the LED. The circuit also includes a circuit for measuring photovoltaic power and the variation of light to determine how much sunlight was received. The current sensor measures the current, the temperature sensor measures the temperature, and the potential divider circuit records the voltage.

#### **6.4 Other Concerns**

Here, we use an LDR to detect the presence of sunshine, and then we turn on the LEDs as a result. With 100K and LDR, we created a possible divider. When sunlight strikes an LDR, its resistance decreases, causing the voltage drop across it to decrease and the voltage drop across a 100K resistor to increase. The 39th pin of the MC will receive the voltage drop across the LDR as LOW logic. Since there won't be any light when night falls, the resistance of the LDR will increase, causing the voltage drop across to increase. This voltage drop is then sensed by the MC as HIGH logic when night falls. The duty cycle of the output LEDs was determined based on the amount of light hitting the LDR. To complete the current flow path through the LEDs, the MOSFET turns ON between its drain and source. As a result, the current flowing through the LEDs decreases as the duty cycle changes from 90% to 10%, leading to the earlier reported decrease in intensity. Solar-powered LED street lights function by turning solar energy into electrical energy by absorbing sunlight through the solar panel. Street lights need to be brightly lit during rush hours, and when there is less traffic on the roads in the late hours, the brightness of the lights can be lowered till morning. This promotes energy conservation. Street lights powered by solar panels turn on and off automatically. The same thing happens every day. Due to their many advantages, solar-powered LED street lights are replacing conventional street lights all over the world. LED lights have a long lifespan. When a street light has auto intensity control, it automatically adjusts its brightness during times of high traffic and totally shuts off during the day.

# CHAPTER 7

## CONCLUSIONS

### 7.1 Conclusions

The streetlight controller based on light intensity and traffic density will be more economical and labor-effective than the pricey and complicated light regulating devices used today. The need of safety and security is important in today's rising nations. A straightforward user interface and an improvement in power output are provided by the Automatic Street Light Controlling System. How to design and construct an automatic street control system circuit is covered in this article. The circuit successfully illuminates or extinguishes a street lamp. Create the circuit that operates the street light by following the instructions in the previous section. Sections. The LDR sensor and photoelectric sensors are the circuit's two primary components. If the two conditions are satisfied, the circuit will carry out the given task in accordance with a predefined program. Each sensor determines whether the lighting column is turned on or off. The microcontroller was successful in controlling the street lights. The controller will provide instructions to the movement's locations to turn on the lights when it becomes dark. Furthermore Since the system now uses a photoelectric sensor instead of a timed controller to operate street lights, the drawback of that method has been removed. Finally, a lengthy highway section might be controlled by this control circuit. Due to these powerful factors, the job at hand offers extra benefits that potentially outweigh current constraints. Although there are long-term advantages, keep in mind that the initial cost will never be a problem because of the early return on investment. Street lighting, smart cities, home automation, agriculture field monitoring, and timed automated lights are just a few of the possibilities for this technology's ease of use. Parking lights, for instance, are present at hospitals, shopping centers, airports, colleges, and enterprises. We may infer that utilizing a dual-axis tracking system is more effective than using a single-axis tracking system because to

the bigger difference in voltage output and the factor of materials and parts used in solar trackers. The results show that a dual-axis tracking system can provide around 20% more power than a single-axis tracking system.

## **7.2 Advantages**

- This will help you conserve energy greatly.
- When the car is not identified, turn off the lights to conserve energy.
- Compared to conventional street lights, solar street lights require substantially less maintenance.
- Since there is no external wire, there is less risk of an accident.
- Separated solar components may be transported to a remote location with ease.
- All available human resources have been used up.
- Reduce the quantity of greenhouse gas emissions into the atmosphere.
- to use transmission cables and solar energy to brighten the streets of rural communities that experience frequent power outages.

## **7.3 Disadvantages:**

- Comparing the initial cost to standard street lighting, it is greater.
- The battery needs a lot of time to charge.
- Energy production may be reduced or even stopped when dust and moisture combine.

## **7.4 Future Scopes of the Work**

The electric charge and intensity of the lights may be adjusted by the sun-controlled LED streetlight with Auto Intensity Control. To add interest to this project, clock- and picture-sensor-based components can be incorporated. We may make use of the sun's location after the building to charge rapidly. We utilize more batteries in the course of operations to conserve more electricity because daylight-based lighting is usually troublesome during the storm season. We employ an LED board to increase lighting. With the help of this project, we will be able to economically and securely link CC Cameras with night vision in metropolitan areas.

## REFERENCES

- [1]<https://digitalcommons.calpoly.edu/cgi/viewcontent.cgi?referer=&httpsredir=1&article=1325&context=eesp>
- [2] A.K. Saxena and V. Dutta, "A versatile microprocessor based controller for solar tracking," in Proc. IEEE, 1990,
- [3]. Yousef, H.A. Design and implementation of a fuzzy logic computer-controlled sun tracking system. In Proceedings of IEEE International Symposium on Industrial Electronics, Bled, Slovenia, Jul. 12-16, 1999
- [4] [https://www.electronics-notes.com/articles/electronic\\_components/resistors/light-dependent-resistor-ldr.php](https://www.electronics-notes.com/articles/electronic_components/resistors/light-dependent-resistor-ldr.php)
- [5] [2] M.T.A. Khan, S.M.S. Tanzil, R. Rahman, S.M.S. Alam. "Design and Construction of an Automatic Solar Tracking System." 6th International Conference on Electrical and Computer Engineering ICECE 2010, 18 – 20 December, Dhaka, Bangladesh.
- [6]<https://sitlersledsupplies.com/4-advantages-led-street-lighting/>
- [7][https://en.wikipedia.org/wiki/Street\\_light](https://en.wikipedia.org/wiki/Street_light)
- [8]<https://www.solarquotes.com.au/good-solar-guide/system-types/>
- [9]<https://www.cleanenergyreviews.info/blog/2014/8/14/what-is-hybrid-solar>
- [10][https://en.wikipedia.org/wiki/Arduino\\_Uno](https://en.wikipedia.org/wiki/Arduino_Uno)
- [11]<https://components101.com/motors/servo-motor-basics-pinout-datasheet>
- [12][https://www.electronics-notes.com/articles/electronic\\_components/resistors/light-dependent-resistor-ldr.php](https://www.electronics-notes.com/articles/electronic_components/resistors/light-dependent-resistor-ldr.php)
- [13]<https://learn.adafruit.com/adafruit-ina219-current-sensor-breakout>
- [14]<https://www.winstar.com.tw/products/oled-module/graphic-oled-display.html>
- [15]<https://voltaicsystems.com/6-volt-solar-panels/>



[16][https://www.google.com/search?q=led&rlz=1C1GCEA\\_enBD941BD941&oq=led&aqs=chrome..69i57j0i67l4j69i60l3.1263j0j7&sourceid=chrome&ie=UTF-8](https://www.google.com/search?q=led&rlz=1C1GCEA_enBD941BD941&oq=led&aqs=chrome..69i57j0i67l4j69i60l3.1263j0j7&sourceid=chrome&ie=UTF-8)

[17][https://en.wikipedia.org/wiki/Lithium-ion\\_battery](https://en.wikipedia.org/wiki/Lithium-ion_battery)

[18][https://en.wikipedia.org/wiki/Jump\\_wire](https://en.wikipedia.org/wiki/Jump_wire)

[19]<https://en.wikipedia.org/wiki/Breadboard>

[20]<https://www.daraz.com.bd/products/pvc-board-for-diy-project-model-or-robotic-chasis-i157436654.html>

## APPENDIX

### Program of C

```
#include <Wire.h>
#include <Adafruit_INA219.h>
#include <Adafruit_GFX.h>
#include <Adafruit_SH1106.h>
#include <SPI.h>

#define SCREEN_WIDTH 128 // OLED display width, in pixels
#define SCREEN_HEIGHT 64 // OLED display height, in pixels
#define OLED_RESET -1

Adafruit_SH1106 display(OLED_RESET);
Adafruit_INA219 ina219;

unsigned long previousMillis = 0;
unsigned long interval = 100;
const int chipSelect = 10;
float shuntvoltage = 0;
float busvoltage = 0;
float current_mA = 0;
float loadvoltage = 0;
float energy = 0;
int topleft;
int topright;
int downleft;
int downright;
int waittime = 1;

void setup() {
  Serial.begin(9600);
  display.begin(SH1106_SWITCHCAPVCC, 0x3C);
  ina219.begin();
  pinMode(9, OUTPUT);
```

```

pinMode(13, OUTPUT); //light pin
pinMode(10, OUTPUT);
TCCR1A = 0;
TCCR1A = (1 << COM1A1) | (1 << COM1B1) | (1 << WGM11);
TCCR1B = 0;
TCCR1B = (1 << WGM13) | (1 << WGM12) | (1 << CS11);
ICR1 = 40000;
OCR1A = 4000;
OCR1B = 3600;
}
void loop() {
  unsigned long currentMillis = millis();
  if (currentMillis - previousMillis >= interval)
  {
    previousMillis = currentMillis;
    ina219values();
    displaydata();
  }
  topleft = analogRead(A0);
  topright = analogRead(A1);
  downleft = analogRead(A2);
  downright = analogRead(A3);

  Serial.println( topleft);
  Serial.println(topright);
  Serial.println(downleft);
  Serial.println(downright);
}

```

```

if(downright&& topleft && topright && downleft> 950)
{
    digitalWrite(13,1);
}
else
{
    digitalWrite(13,0);
}
if (topleft > topright) {
    OCR1A = OCR1A + 1;
    delay(waittime);
}
if (downleft > downright) {
    OCR1A = OCR1A + 1;
    delay(waittime);
}
if (topleft < topright) {
    OCR1A = OCR1A - 1;
    delay(waittime);
}
if (downleft < downright) {
    OCR1A = OCR1A - 1;
    delay(waittime);
}
if (OCR1A > 4000) {
    OCR1A = 4000;
}
if (OCR1A < 2000) {
    OCR1A = 2000;
}
if (topleft > downleft) {

```

```

    OCR1B = OCR1B - 1;
    delay(waittime);
}
if (topright > downright) {
    OCR1B = OCR1B - 1;
    delay(waittime);
}
if (topleft < downleft) {
    OCR1B = OCR1B + 1;
    delay(waittime);
}
if (topright < downright) {
    OCR1B = OCR1B + 1;
    delay(waittime);
}
if (OCR1B > 4200) {
    OCR1B = 4200;
}
if (OCR1B < 3000) {
    OCR1B = 3000;
}
}

void displaydata() {
display.clearDisplay();
display.setTextColor(WHITE);
display.setTextSize(1.3);
display.setCursor(0, 0);
display.println(loadvoltage);
display.setCursor(35, 0);
display.println("V");
display.setCursor(50, 0);

```

```

display.println(current_mA);
display.setCursor(95, 0);
display.println("mA");
display.setCursor(0, 10);
display.println(loadvoltage * current_mA);
display.setCursor(65, 10);
display.println("mW");
display.setCursor(0, 20);
display.println(energy);
display.setCursor(65, 20);
display.println("mWh");
display.display();
}
void ina219values() {
    shuntvoltage = ina219.getShuntVoltage_mV();
    busvoltage = ina219.getBusVoltage_V();
    current_mA = ina219.getCurrent_mA();
    loadvoltage = busvoltage + (shuntvoltage / 1000);
    energy = energy + loadvoltage * current_mA / 3600;
}

```