

“Comparison of Particle Swarm Optimization Based MPPT Controller with Conventional MPPT Controller for PV System”

A thesis is submitted in partial fulfillment of the requirements for the award of Degree of Bachelor of Science in Electrical and Electronic Engineering.

Submitted by

Md. Shihabul Islam

ID: 191-33-5025

Department of EEE

Sadiquzzaman

ID: 191-33-5068

Department of EEE

Supervised by

Dr. Fahmida Hossain Tithi

Associate Professor,

Department of Electrical and Electronic Engineering



Department of Electrical and Electronic Engineering

Faculty of Engineering

DAFFODIL INTERNATIONAL UNIVERSITY

FEBRUARY, 2023

DECLARATION

I hereby declare that this thesis “**Comparison of particle swarm optimization based MPPT controller with conventional MPPT controller for PV system**” represents my own work which has been completed in the Electrical and Electronic Engineering Departments of the Faculty of Engineering at Daffodil International University in partial fulfillment of the requirements for the degree of Bachelor of Science in Electrical and Electronic Engineering, and which has not earlier been incorporated into a thesis or dissertation submitted to this or any other institution for a degree, diploma, or other qualifications. In conducting this research, I have efforted to detect all potential dangers, I have also received the necessary ethical and/or safety approvals, accepted my responsibilities, and respected the rights of the participants.

Signature of the candidates



.....
Md. Shihabul Islam

ID: 191-33-5025



.....
Sadiquzzaman

ID: 191-33-5068

APPROVAL

This thesis titled “**Comparison of Particle Swarm Optimization Based MPPT Controller with Conventional MPPT Controller for PV System**” submitted by **Md. Shihabul Islam (191-33-5025) & Sadiquzzaman (191-33-5068)** have been completed under my supervision and are approved as satisfactory in completing a portion of the prerequisites for the degree of **Bachelor of Science in Electrical and Electronic Engineering** in **February, 2023**.

Signed



.....
Dr. Fahmida Hossain Tithi

Associate Professor,
Department of EEE
Faculty of Engineering
Daffodil International University

DEDICATION

“Dedicated to
OUR PARENTS,
TEACHERS
&
ALL WELL-WISHERS
With Love & Respect”

CONTENTS

TABLE OF CONTENTS	vi-vii
LIST OF FIGURES	viii-ix
LIST OF TABLES	x
LIST OF ABBREVIATIONS	xi
ACKNOWLEDGMENT	xii
ABSTRACT	xiii

TABLE OF CONTENTS

CHAPTER 1: INTRODUCTION

1.1 Background:.....	1
1.2 Statement of Problems and Perspectives:.....	1
1.3 Objectives of the Thesis:.....	2
1.4 Literature Review:	2
1.5 Thesis Structure	4

CHAPTER 2: FUNDAMENTALS OF SOLAR ENERGY

2.1 Photovoltaic Solar Cell.....	5
2.1.1 Operating Principle of Photovoltaic Cell	5
2.1.2 Equivalent Circuit of a Photovoltaic Cell.....	6
2.1.3 Some Important Terms:.....	7
2.1.4 Effects of Temperature and Irradiance.....	13
2.1.5 Different Type of Solar Cell.....	14
2.2 Photovoltaic Modules:.....	17
2.3 Photovoltaic (PV) System Configuration:	18
2.3.1 Stand-Alone PV System:	18
2.3.2 Grid-Connected PV System:	19

CHAPTER 3: MAXIMUM POWER POINT TRACKING (MPPT)

3.1 Introduction:	20
3.2 Perturb and Observe (P&O) Technique:	20
3.3 Incremental Conductance Technique:	23
3.4 Particle Swarm Optimization Technique:	25
3.5 Some Other MPPT Technique:	27
3.5.1 Fractional Open-Circuit Voltage (FOCV):.....	27

3.5.2 Fractional Short-Circuit Current (FSCC):	27
3.5.3 Fuzzy Logic Control:	28
3.5.4 Neural Network (NN):.....	28
 CHAPTER 4: DC-DC BOOST CONVERTER	
4.1 Boost Converter:	29
4.2 Design of DC-DC Boost Converter with the Suggested System.:.....	31
 CHAPTER 5: SYSTEM SIMULATION AND PERFORMANCE ANALYSIS	
5.1 Introduction:	32
5.2 Exhaustive Simulink PV System:	32
5.2.1 Perturb and Observe (P&O) Techniques:	32
5.2.2 Incremental Conductance (IC) Techniques:	33
5.2.3 Particle Swarm Optimization (PSO) Techniques:.....	34
5.3 Results of simulation	35
 CHAPTER 6: CONCLUSION AND FUTURE WORK	
6.1 Conclusion:.....	41
6.2 Future Work:	41
 REFERENCES	42

LIST OF FIGURES

Fig. 2.1: Photovoltaic cell schematic	5
Fig. 2.2: Equivalent circuit of solar cell.....	6
Fig. 2.3: I-V curve of PV cell (Short Circuit Current).....	7
Fig. 2.4: I-V curve of PV Cell (Open Circuit Voltage)	9
Fig. 2.5: V-I Characteristics curve of a single PV module	10
Fig. 2.6: P-V Characteristics curve of PV cell	11
Fig. 2.7: Fill Factor for a PV Cell	12
Fig. 2.8: V-I Temperature Effect in a Solar Cell	13
Fig. 2.9: IV curves of PV module at different irradiation levels	13
Fig. 2.10: Monocrystalline, Polycrystalline & Thin-film silicon Solar Cell.	15
Fig. 2.11: Cadmium Telluride (CdTe) solar cell.....	16
Fig. 2.12: Ordinary construction of a Crystalline PV cell	17
Fig. 2.13: Classical sketch of Stand-alone PV system.....	19
Fig. 2.14: Classical sketch of Grid Connected PV system	19
Fig. 3.1: Sketch of Perturb and Observe techniques.....	21
Fig. 3.2: Performance Rules of P&O techniques.....	22
Fig. 3.3: Conceptual foundation of the IC techniques	23
Fig. 3.4: Sketch of IC techniques.....	24
Fig. 3.5: Sketch of PSO techniques.....	26
Fig. 4.1: Sketch of a simple boost converter.....	29
Fig. 4.2: Sketch of Boost Converter with MPPT Controller & Solar Panel	31
Fig. 5.1: P&O technique Simulink model with dc-dc boost converter	33

Fig. 5.2: IC technique Simulink model with dc-dc boost converter	34
Fig. 5.3: PSO technique Simulink model with dc-dc boost converter.....	35
Fig. 5.4: Output power curve (P&O technique).....	36
Fig. 5.5: Output power curve (IC technique).....	36
Fig. 5.6: Output power curve (PSO technique).....	37
Fig. 5.7: Comparison curve of output power (P&O, INC, and PSO)	37
Fig. 5.8: Comparison curve of efficiency (P&O, INC, PSO)	38
Fig. 5.9: Comparison curve of output voltage (P&O, INC, PSO)	39

LIST OF TABLES

Table 3-1: Short Working Conception of P&O Techniques.....	22
Table 3-2: Features of various MPPT techniques.....	27
Table 5-1: Efficiency comparison between P&O, IC & PSO MPPT methods.....	40

LIST OF ABBREVIATIONS

AC	Alternating Current
DC	Direct Current
MPPT	Maximum Power Point Tracking
CIGS	Copper Indium Gallium Selenide
EVA	Ethyl Vinyl Acetate
R&D	Research and Development
MPP	Maximum Power Point
IC	Incremental Conductance
GaAs	Gallium Arsenide
PWM	Pulse Width Modulation
CdTe	Cadmium Telluride
FF	Fill Factor
P&O	Perturb and Observe
FOCV	Fractional Open-Circuit Voltage
IGBT	Insulated-Gate Bipolar Transistor
STC	Standard Test Conditions
PSO	Particle Swarm Optimization
FSCC	Fractional Short Circuit Current
CCM	Continuous Conduction Mode
PV	Photovoltaic
MOSFET	Metal-Oxide-Semiconductor Field-Effect Transistor
NN	Neural Network
FLC	Fuzzy Logic Control

ACKNOWLEDGEMENT

The research for this thesis was accomplished at the Daffodil International University Department of Electrical and Electronic Engineering. I want to thank everyone who has helped with this work, both directly and indirectly through organizations and individuals.

To begin with, I want to thank my supervisor **Dr. Fahmida Hossain Tithi** for providing me with the chance to work with him. Without his essential direction, counsel, and assistance, this endeavor wouldn't have been possible to complete. He has taught me a lot while I've been working on this thesis.

Additionally, I want to thank all of my friends at DIU for bringing joy, excitement, and vitality into my life, which was sometimes reduced by the pressures of undergraduate studies. My parents have always given me a ton of encouragement to go after the things I want. For everything they gave up for me, I will always be grateful.

Finally, I would want to thank my family for all of their love, motivation, and encouragement throughout these marvelous moments.

ABSTRACT

The MPP (Maximum Power Point) of a photovoltaic system is not constant because it relies on the ambient temperature, solar radiation and load impedance. PV modules have a point at which they can reach their MPP under any conditions. A maximum power point tracking technique is needed to keep the PV panel operating at its MPP. In this study, the PSO method is compared to the conventional MPPT techniques (P&O, IC) utilized in PV systems. Using the MATLAB/Simulink software, the suggested PSO MPPT technique has been implemented on a DC-DC Boost converter and compared to the P&O and INC techniques in terms efficiency. The outcome of the simulation demonstrates that the suggested technique is straightforward and superior to the P&O and INC techniques.

CHAPTER 1

INTRODUCTION

1.1 Background:

We can access purified & limitless energy from renewable sources. When usual decayed sources such as fossil fuel are continuously used to generate energy, the supply of that capability is depleted. The biggest issue is the rising global warming brought on by the use of fossil fuels to produce power. As a result, using renewable energy will be a preferred option for providing our need for electricity while protecting the environment. Due to its lower pollution and environmental protection solar energy is currently the most widely used renewable energy source.

1.2 Statement of Problems and Perspectives:

Albeit, the generation of solar energy is a reliable system of generation renewable energy but some problems also. The efficiency of solar cell is less. And mainly its efficiency varies with environmental conditions of the surrounding (i.e. solar rays, temperature, partial shading, etc.). Hence to maximize efficiency, several types of MPPT techniques are applied. This is a procedure used for getting maximum possible power from variable sources. Due to the non-linear V-I feature of PV arrays and their specific point of maximum power generation, MPPT techniques are required. Throughout the day and the varied seasons during the year, this point changes constantly. Additionally, irradiation can change rapidly due to changing atmospheric conditions such as cloud. For maximal power drainage from the photovoltaic cells, it is crucial to track the MPP precisely at all conditions. Thus, MPPT methods are incorporated.



1.3 Objectives of the Thesis:

This study compares various MPPT strategies for maximizing ability extraction from photovoltaic models with a Boost-Converter and evaluates the proficiency of that technique when used with a PV system that has been specifically developed. The aim of the thesis can be described as-

- Reviewing the theoretical background of solar power generation.
- Reviewing different type of MPPT techniques.
- Design DC-DC Boost Converter for the proposed system.
- Mathematical modeling of Photovoltaic solar cell in MATLAB/SIMULINK.
- Development of the P&O, INC & PSO MPPT Algorithm for the proposed PV system for extracting maximum power from the system.
- In MATLAB/SIMULINK software, this photovoltaic scheme is simulated with these three techniques & assessing those three algorithms' performance to maximize PV system extraction.

1.4 Literature Review:

A few instances of concerned work that has been done in the prior allude in this section of the preface. Various MPPT approaches have been developed and tested over the last several decades to order to maximize output power via solar photovoltaic systems under a variety of atmospheric conditions. The majority of the research papers presented below include P&O, IC method, also mentioned PSO method and to order to get the most power out of photovoltaic systems. To obtain the MPP (Maximum Power Point) in this thesis work, boost converter is used with P&O, IC & PSO technique using the MATLAB software, and the code is converted into C-code and performed the algorithm operation, in the reviewed work, they implement the technique in Simulink by designing Simulink subsystem block. And mainly most of the reviewed papers evaluate their system efficiency either manually or by implementing the whole system in practically, but in this thesis paper, the system efficiency is illustrated graphically over the time period in MATLAB/SIMULINK. Thus, it is becoming very easy to visualize the performance of the system with changing atmospheric conditions. Some of the reviewed research works are mentioned below:

- **Kshitijaa Ranjan and Narendra Kumar** (2016) [1]. Department of Electrical Engineering, Delhi Technological University, Delhi, India exhibited a research study on **“Modelling and simulation of Perturb and Observe algorithm on solar PV system using different converters in MATLAB/SIMULINK”** [1]. In this research, they primarily used the P&O algorithm, DC-DC buck converters, and DC-DC boost converters to accomplish the MPP under a variety of atmospheric conditions.
- **Md. Hanif Reza and Md. Asaduzzaman Shobug** (2020) [2]. Department of Electrical Engineering, Pabna University of Science & Technology, Pabna, Bangladesh revealed a research work on **“Efficiency Evaluation of P&O MPPT Technique used for Maximum Power Extraction from Solar Photovoltaic System”** [2].
- **Trishan Eswam and Patrick L. Chapman** (2007) [3]. Member of IEEE exhibited a research work on **“Comparison of photovoltaic array maximum power point tracking techniques”** [3].
- **William Christopher and Dr. R. Ramesh** (2013) [4]. Department of EEE, Tagore Engineering College, Chennai, India revealed a research work on **“Comparative Study of P&O and InC MPPT Algorithms”** [4]. In this study, they compare the results of P&O and IC MPPT method for extracting maximum power from SPV system.
- **Ze Cheng, Hang Zhou and Hongzhi Yang** (2010) [5]. School of Electrical Engineering and Automation, Tianjin University, Tianjin exhibited a research study on **“Research on MPPT control of PV system based on PSO algorithm”** [5].
- **Saurabh Thakran, Jaspreet Singh, Prof. Rachan Garg and Dr. Priya Mahajan** (2018) [6]. Department of Electrical Engineering, Delhi Technological University, Delhi revealed a research work on **“Implementation of P&O Algorithm for MPPT in SPV System”** [6].
- **Kriti Jain, Prof. Manju Gupta and Dr. Aashish Kumar Bohre** (2021) [7]. Oriental Institute of Science and Technology, Bhopal, India exhibited a research study on **“Implementation and Comparative Analysis of P&O and INC MPPT Method for PV System”** [7].

- Dr. Rachana Garg, Dr. Alka Singh and Shikha Gupta (2014) [8]. Delhi Technology University Delhi, India Tianjin exhibited a research study on “**PV Cell Models and Dynamic Simulation of MPPT Trackers in MATLAB**” [8].
- Sehrish Khan and Rasheed Ahmed Qazi (2019) [9]. Engineering Department Sukkur IBA University Sukkur, Pakistan revealed a research work on “**Implementation of an Efficient MPPT Algorithm for Photovoltaic System**” [9].
- Arshdeep Singh and Shimi S.L. (2017) [10]. Department of Electrical Engineering NITTTR Chandigarh, India revealed a research work on “**Implementation of an Efficient MPPT Algorithm for Photovoltaic System**” [10].

1.5 Thesis Structure:

The content of this thesis has been arranged in the following manner:

- **Chapter 1** includes the motivation behind this thesis work, Problem statement, approach to solve the problem, objectives of the thesis, Literature review and thesis layout.
- **Chapter 2** includes background of solar photovoltaic (PV) power generation, the equivalent circuit of PV cell, characteristics of PV cell, different types of cells, components and configuration of the PV system.
- **Chapter 3** provides introduction of P&O, INC & PSO MPPT technique also includes the introduction of different types of MPPT techniques.
- **Chapter 4** provides an explanation of designing DC-DC boost converter for proposed system.
- **Chapter 5** outcomes of the suggested systems and the explaining.
- **Chapter 6** includes conclusions and suggestions for future work.

CHAPTER 2

FUNDAMENTALS OF SOLAR ENERGY

2.1 Photovoltaic Solar Cell:

2.1.1 Operating Principle of Photovoltaic Solar Cell:

By using the photovoltaic effect, the solar cell, also known as a photovoltaic cell, transforms solar energy into electrical energy [11]. Two different semiconductors are used in solar cells. Figure 2.1 represents the n-type and p-type layers as well as a close-up of the depletion zone that surrounds the junction between the two types of layers.

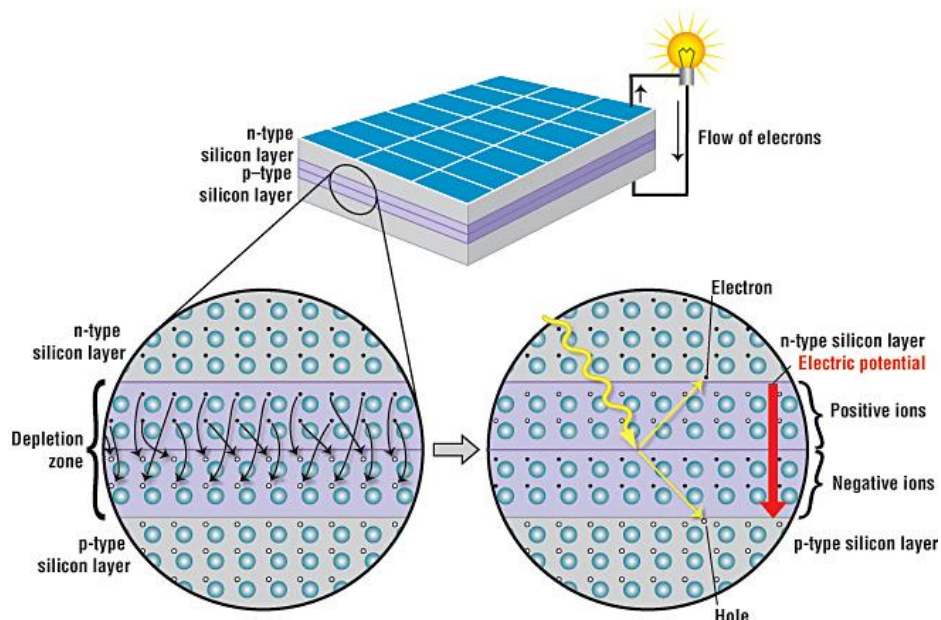

Fig. 2.1: Photovoltaic cell schematic [12].

There are too many electrons in the n-type layer and too many positively charged holes in the p-type layer. The electrons on one side of the junction (n-type layer) migrate into the holes on the opposite side of the junction close to the junction of the two layers (p-type layer). As a result, a region known as the depletion zone is formed surrounding the connection, where the electrons fill the holes. The p-type flank of the depletion zone, which previously contained holes, is now loaded with negatively charged ions, and the n-type flank of the depletion zone, which previously contained electrons, is filled with positively charged ions. This happens when all the gaps in the depletion zone are loaded with electrons. Due to the inward electric field produced by these oppositely charged ions, the n-type layer's electrons are unable to completely

fill the p-type layer's gaps. Vacancies left abaft by the outgoing electrons cause "holes" to appear when sunlight hits a solar cell, which is made of silicon. In this scenario, the electric field will transfer holes to the p-type layer and electrons to the n-type layer. If you connect the n-type and p-type layers with a metallic wire, electrons will move from the n-type layer to the p-type layer by crossing the depletion zone and then moving through the external wire back of the n-type layer, causing an electrical flow [12].

2.1.2 Equivalent Circuit of a Photovoltaic Solar Cell:

The single-diode model of the solar cell is demonstrated in figure 2.2 [1]. Based on a mathematical formula, a Simulink model of a solar cell is created. A photovoltaic array model is then created using an additional simulation of this model. Solar cells are connected in parallel and in series to provide the needed power. A photovoltaic module is a collection of solar cells, and a photovoltaic array is a collection of photovoltaic modules. As shown in the below figure, a photovoltaic cell can be explained as an electrical circuit [1].

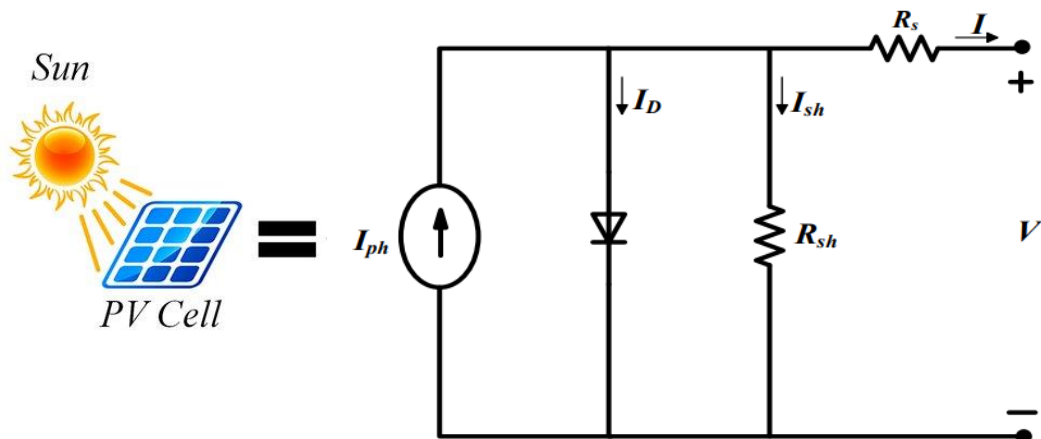

Fig. 2.2: Equivalent circuit of solar cell [1].

$$I = I_{ph} - I_0 \left[\exp \left(\frac{q(V+IR_s)}{nKT} \right) - 1 \right] - \frac{V-IR_s}{R_{sh}} \quad \dots\dots\dots (1)$$

Where,

V = Output Voltage (V), I = Output current (A), I₀ = Reverse saturation current, I_{ph} = Photocurrent, R_{sh} = Shunt Resistance (ohm), R_s = Series resistance (ohm), n = Ideality factor, T = Temperature in Kelvin, K = Boltzmann's constant(j/K) [1].

Numerous solar cells are attached in series & parallel to create a PV panel, that generates a large sufficient output current & voltage to suit the needs of the grid or other materials. Considering the preceding generalization, eq. (2), expressing the output current-voltage characteristic of a PV panel.

$$I = N_p I_{ph} - N_p I_0 \left[\exp \left(\frac{q(V + IR_s)}{nKT N_s} \right) - 1 \right] \quad \dots\dots\dots (2)$$

Where,

N_s = Number of solar cell (Series)

N_p = Number of solar cell (Parallel)

2.1.3 Some Important Terms:

2.1.3.1 Short Circuit Current of Solar cell:

When there is no voltage across the solar cell, there is no current flowing through it, which is known as the short-circuit current, in other words when the solar cell is short-circuited. The creation and gathering of carriers produced by light cause the short-circuit current. The short-circuit current & light-generated current for a perfect solar cell are the same, even at relatively mild resistive loss mechanisms. The maximum current that can be obtained from a solar cell is the short-circuit current as a result. Short-circuit current, which is generally abbreviated as I_{SC} , which viewed on the below IV curve [13].

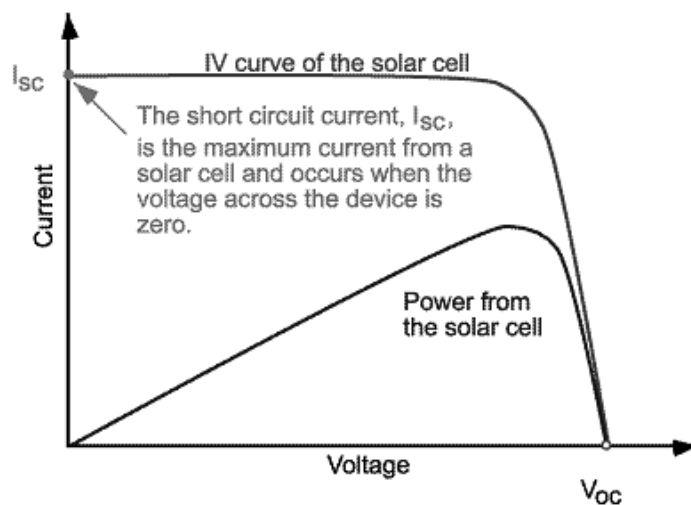

Fig. 2.3: I-V curve of PV cell (Short Circuit Current) [13].

The most important material parameters to consider when comparing solar cells made of the same material are diffusion length and surface passivation. The short-circuit current density formula in a cell with a properly inactive surface & similar generation is roughly given by [13]:

$$J_{SC} = qG (L_n + L_p)$$

Where,

G = Generation rate

L_n = Electron diffusion length

L_p = Hole diffusion length

The above formula states that the short-circuit current substantially relies on the generation rate and the diffusion length, even though the fact that it makes various assumptions that are untrue for the conditions seen in the majority of solar cells [13].

$$I_{SC} = J_{SC}A$$

Where,

I_{sc} = Short circuit current,

J_{sc} = Maximum current density

A = Area of solar cell

2.1.3.2 Open Circuit Voltage of Solar Cell:

When there is no load attached to the cell, the voltage between its terminals is monitored. This voltage is influenced by manufacturing processes and temperature, but less so by light intensity and exposed surface area. Solar cells typically have an open circuit voltage between 0.5 and 0.6 volts. V_{OC} is typically used to indicate it [14].

The highest voltage a solar cell may produce is known as the open-circuit voltage, or V_{OC} , and it happens when there is no current flowing through it. According to the solar cell junction's bias caused by the current created by light, the open-circuit voltage reflects how much forward bias the solar cell has. Below is an IV curve that displays the open-circuit voltage [15].

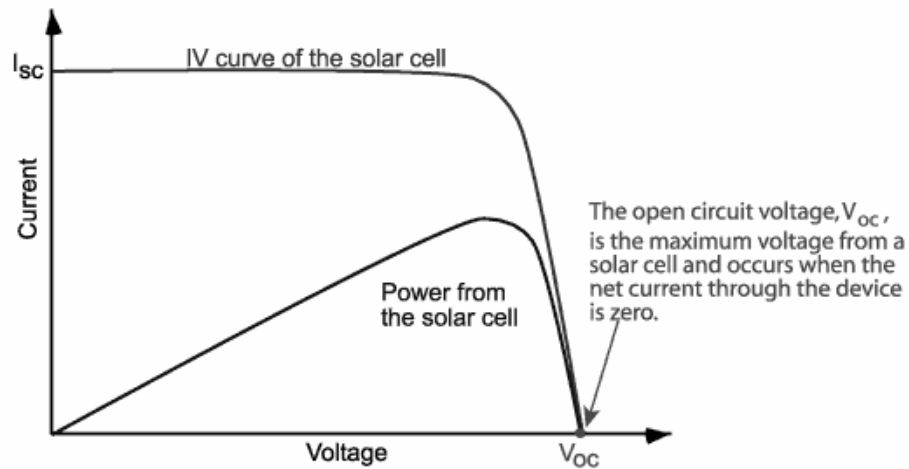

Fig. 2.4: I-V curve of PV Cell (Open Circuit Voltage) [15].

By making the net current in the PV cell formula equal to zero, the following formula for V_{OC} is obtained:

$$V_{OC} = \frac{nkT}{q} \ln \left(\frac{I_L}{I_0} + 1 \right)$$

Additionally, the V_{OC} can be calculated from the carrier concentration and Implied V_{OC} is another term for determining a V_{OC} based on the carrier concentration [15].

$$V_{OC} = \frac{kT}{q} \ln \left[\frac{(N_A + \Delta n)\Delta n}{n_i^2} \right]$$

Where,

kT/q = Thermal voltage,

N_A = Doping concentration,

Δn = Excess carrier concentration

n_i = Intrinsic carrier concentration.

2.1.3.3 V-I Characteristic of a Photovoltaic Solar cell:

The correlation between a module's current and voltage is expressed visually by the IV curve. A sketch of a typical IV curve for a single PV module is shown below.

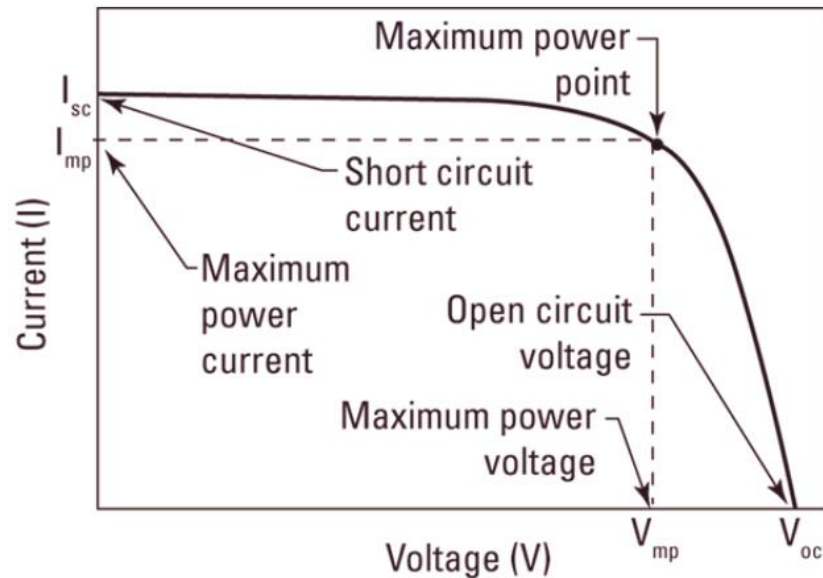

Fig. 2.5: V-I Characteristics curve of a single PV module [16].

The major electrical features of figure 2.5 are:

- ❖ **MPP:** Where the current is multiplied by voltage and maximal output power is obtained.
- ❖ **V_{oc}:** Where the voltage is at its maximum for a particular temperature and current equals zero.
- ❖ **V_{mp}:** Where the voltage value intersects the MPP.
- ❖ **I_{sc}:** The point on the curve that represents a voltage value of zero and the amount of current that would flow if the positive and negative wires were placed in direct contact with each other.
- ❖ **I_{mp}:** The point where the current value intersects the MPP [16].

2.1.3.4 Maximum Power Point of Photovoltaic Solar Cell:

The highest amount of electrical power a solar cell is capable of producing under standard test condition. Maximum power will happen at the bend point of the characteristic curve if we draw the V-I properties of a solar cell. It is displayed by P_M in the V-I properties of solar cells. And here, I_M = Current at Maximum Power Point, V_M = Voltage at Maximum Power Point [17].

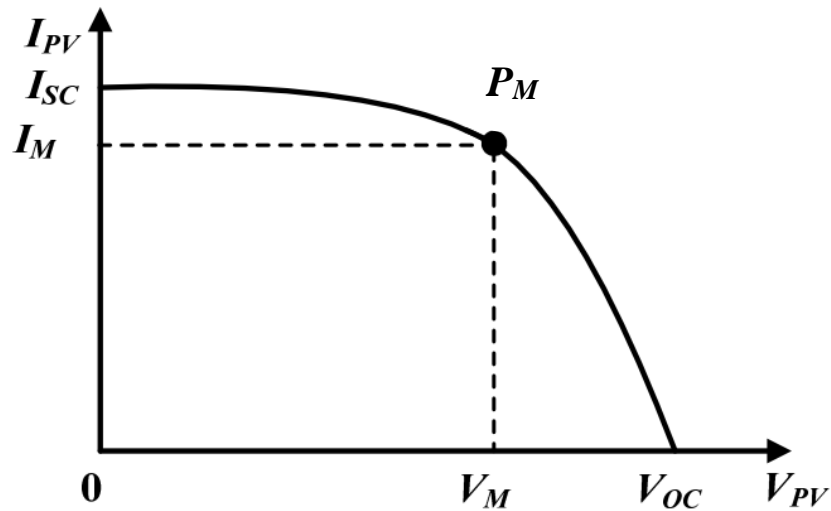

Fig. 2.6: P-V Characteristics curve of PV cell [17].

2.1.3.5 Fill Factor (FF):

A PV cell's fill factor is a significant parameter to consider when assessing its ability since it shows how near a PV cell is to producing the maximum theoretical output power. The fill factor measures the difference between the cell's actual maximum power output and its theoretic maximum power output (V_{MPP} and I_{MPP} , respectively). The typical fill factor for commercial solar cells is usually over 0.70 [18].

$$FF = \frac{I_{MPP}V_{MPP}}{I_{SC}V_{OC}}$$

Where,

FF = Fill factor

V_{MPP} = Voltage at the maximum power point

I_{MPP} = Current at the maximum power point

V_{OC} = Open circuit voltage

I_{SC} = Short circuit current

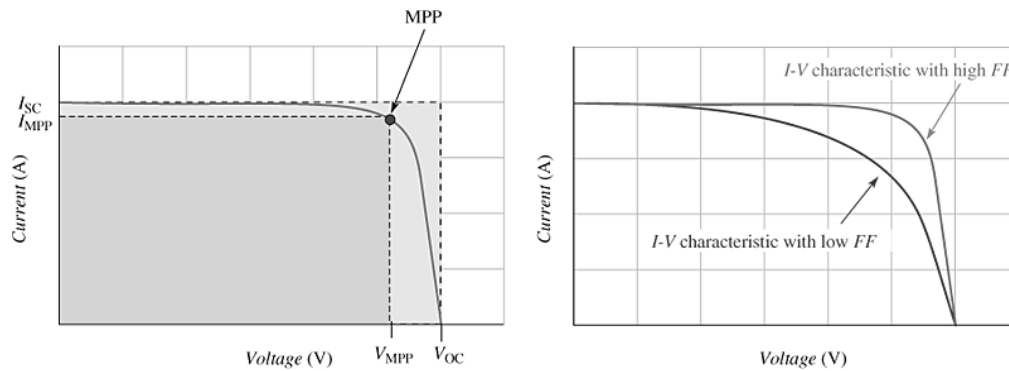

Fig. 2.7: Fill Factor for a PV Cell [18].

2.1.3.6 Efficiency of Solar Cell:

Its definition is the ratio of maximal electrical power output to the radiation power input to the cell and it is expressed in percentage. Considering that the radiation power on the planet is around 1000 watts per square meter, the total radiation power on the cell will be 1000 A watts if it has a surface area of A. Consequently, one way to describe a solar cell's efficiency is [17] .

$$Efficiency (\% \eta) = \frac{P_m}{P_{in}} \approx \frac{P_m}{1000A} \times 100$$

2.1.4 Effects of Temperature and Irradiance:

A PV cell's output voltage and current are temperatures relied on. Fig- 2.8 demonstrates that, for fixed light output, the open circuit output voltage reduces with temperature due to a change in the band gap, while the current is only marginally impacted. Here, it's crucial to remember that a PV cell works best in cooler temperatures [18].

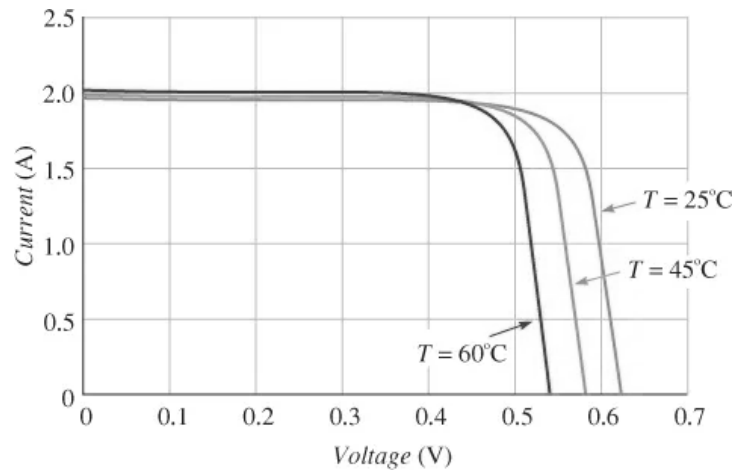

Fig. 2.8: V-I Temperature Effect in a Solar Cell [18].

Each day, the irradiance varies widely, peaking at more than 1,000 W/m² at any proffered time after rising at 0 W/m² immediately before dawn. The amount of current a PV module can produce directly depends on the quantity of irradiance it receives. This is a linear relationship that can be calculated under different circumstances, just like the relationship between voltage and temperature [16].

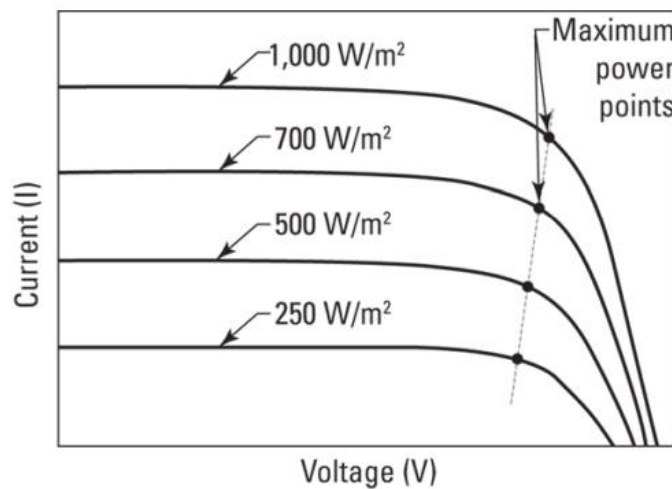

Fig. 2.9: IV curves of PV module at different irradiation levels [16].

The IV curve's relationship to irradiance changes is depicted in Figure 2.9. Here we see that how the curves move far more vertically than they do horizontally. This stroll suggests that although the current is significantly impacted by variations in irradiance, the voltage of the module isn't significantly altered. Due to variations in irradiance, the MPP also varies considerably [16].

2.1.5 Different Type of Solar Cell:

Solar cells for terrestrial applications are generally made from silicon as single-crystal, polycrystalline, or amorphous solids. The most effective silicon is single-crystal silicon because it lacks grain boundaries, which are flaws in the crystal structure brought on by changes in the lattice and have a tendency to reduce the material's electrical and thermal conductivity. They could be viewed as obstacles to electron flow. The grain borderer of polycrystalline silicon is distinct, and single crystal fragments are readily seen. The non-crystalline type of silicon with relatively haphazardly distributed atoms is known as amorphous silicon (a-Si). Some atoms contain dangling ties that obstruct the flow of electrons because the substance is disordered. Although amorphous silicon is the least costly to produce, it has the lowest power conversion efficiency of the three varieties [19] [20].

2.1.5.1 Monocrystalline silicon:

The raw material for making monocrystalline silicon cells is an ingot of a single silicon crystal that has been produced in sophisticated labs, cut into thin slices, doped, and then etched. Efficiency levels for commercial terrestrial modules typically fall between 15% and 20%. The most developed modules available are made of this kind of cell. Reputable producers of this kind of PV module provide warranties of up to 20–25 years at 80% of the nameplate rating [20].

2.1.5.2 Polycrystalline silicon:

These cells are made up of various silicon crystals formed from an ingot. In addition, they are cut, doped, and etched. Their conversion efficiency ranges from 13 to 15%, which is slightly less than those of monocrystalline cells. Polycrystalline PV modules from reputable manufacturers often come with a 20-year warranty [20].

2.1.5.3 Amorphous & Thin-film silicon:

The absence of any geometric cell structure is referred to as amorphous. The absence of any geometric cell structure is referred to as amorphous. In contrast to crystalline silicon, amorphous modules lack the ordered pattern characteristic of crystals. Conversion rates for commercial modules typically range between 5 and 10%. Depending on the manufacturer, most product guarantees last for ten years. The technique hasn't been widely adopted for higher power applications in large part because shorter lifetimes from faster cell deterioration in sunlight (degradation to 80% of original output in most situations) make the technology less practical. However, amorphous PV has become very popular for usage in consumer electronics (e.g., watches and calculators). For some grid-connected or water-pumping applications, it does have an advantage in that higher voltage modules can be made more affordably than their crystalline equivalents. The existence of material traps is another issue that lowers efficiency. The recombination of electrons and holes can be significantly increased by traps, which are semiconductor material imperfections in the depletion area. Recombination lowers V_{OC} , which lowers the efficiency and fill factor [20].

Thin-film is the newish-type photovoltaic products that are now available. The thin film materials copper indium diselenide, cadmium telluride, and gallium arsenide are all directly deposited on glass, stainless steel, ceramic, or other suitable substrate materials, and their usual thickness is a few μm or less. This technicality is less costly per watt of energy produced since it utilizes a lot less material per square area of the cell [21].

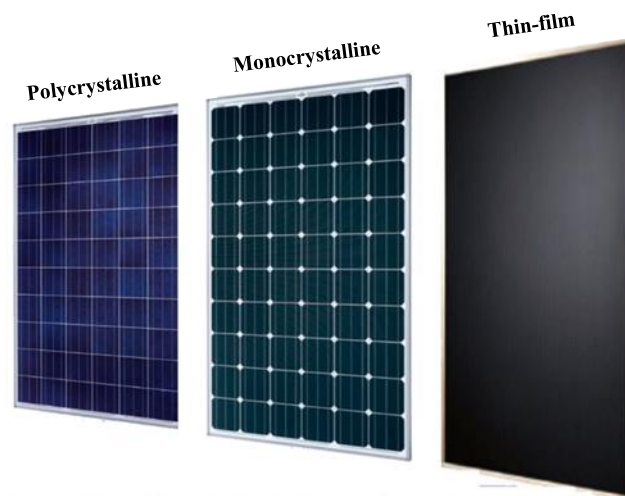

Fig. 2.10: Monocrystalline, Polycrystalline & Thin-film silicon Solar Cell.

Cadmium telluride (CdTe), copper indium gallium selenide (CIGS), and amorphous thin-film silicon are the three most popular types of thin-film solar cells (a-Si) [22].

2.1.5.4 Copper indium gallium selenide (CIGS): Another typical thin-film solar cell is the CIGS (copper indium gallium selenide) cell. Cause copper indium gallium selenide has a high absorption coefficient, the cell has demonstrated great efficiency. Although the efficiency in the lab is higher than 20%, on a commercial scale, it is between 12 and 14%. The cost of CIGS technology is one of its key limitations [22].

2.1.5.5 Cadmium telluride (CdTe): Solar energy is absorbed by cadmium telluride (CdTe), which is used in solar cells. Due to lower production costs and a less carbon impact, they continue to be the most popular thin-film cells. Of the overall photovoltaic market, CdTe provides 5%. When compared to the practical c-Si cell, these PV cells have the advantage of being more affordable to produce. They lack effectiveness, though. 22.1% by First Solar is the highest lab efficiency that is currently known. When measured on a commercial basis, this figure drops to 16.1%. Leading suppliers of CdTe cells include First Solar, the biggest solar manufacturer in the United States. Additionally, the business has been spending money on R&D to boost CdTe's effectiveness. Its acceptability is also severely constrained by the toxicity of cadmium and the dearth of tellurium in the earth's crust [22].

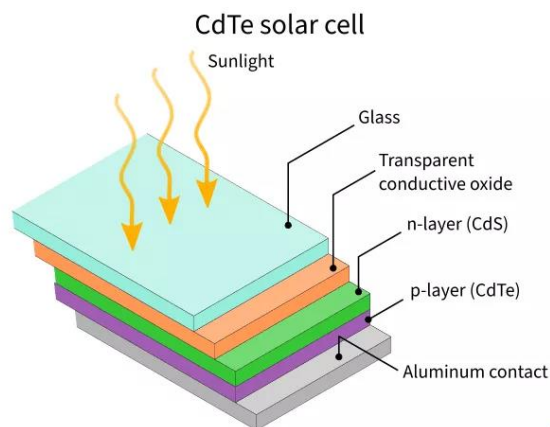

Fig. 2.11: Cadmium Telluride (CdTe) solar cell [22].

2.1.5.6 Gallium Arsenide (GaAs): The two materials gallium & arsenic combined to form gallium arsenide (GaAs). The smelting of other metals, especially aluminum and zinc, produces gallium, which is rarer than gold. However, although being dangerous, arsenic is not unusual. A cell only a few millimeters thick is all that is needed for gallium arsenide to absorb sunlight due to its extremely high absorptivity. Heat has little effect on GaAs cells, and radiation damage is extremely difficult to cause. It can therefore be used in space applications and concentrator systems [23].

2.2 Photovoltaic Modules:

The power in a PV system comes from PV modules [16]. To supply the necessary current or voltage to operate electrical loads, PV cells are electrically connected in series and parallel. In order to build a PV module, PV cells are linked in series, aggregated, laminated, and packaged between sheets of plastic and glass [20]. An edge of an ordinary module with crystalline silicon solar cells is shown in a cut-away perspective in Figure 2.12.

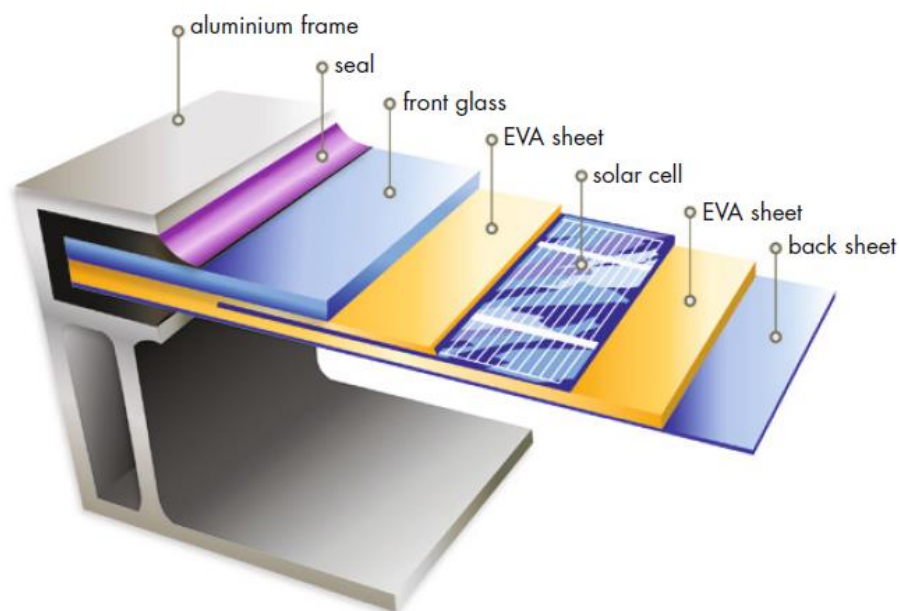

Fig. 2.12: Ordinary construction of a Crystalline PV cell [24].

The fragile cells are protected by being enclosed in an airtight covering of ethyl vinyl acetate (EVA) to ensure that handling doesn't damage them. An antireflection coating (ARC) may

occasionally be applied to tempered glass to increase light transmission on the top. A light synthetic polymer back sheet that serves as a defense against moisture infiltration and chemical deterioration is present underneath. The entire "sandwich" is inserted into an aluminum frame slot and seal in place. An extremely demanding specification requires that this formation resists up to 25 to 30 years of outside exposure to the elements, including desert sands, mountain snows, wind, rain, pollutants, and extremes of temperature and humidity. Whenever anything goes wrong, moisture intrusion or electrical contact corrosion is frequently at blame rather than solar cell defects. Whenever anything goes wrong, moisture intrusion or electrical contact corrosion is frequently at blame rather than solar cell defects [25].

2.3 Solar Photovoltaic (PV) System Configuration:

In ordinary, photovoltaic power systems are categorized based on their functional and operational requirements, component configurations, and how the components are coupled to other power sources and electrical loads. The two main classes are [26]:

1. Stand-alone PV systems
2. Grid connected PV systems

2.3.1 Stand-Alone PV System:

These systems are self-contained and not connected to utility power lines. This system typically includes electricity-consuming items like solar street lighting, solar lanterns, and solar power plants as well as solar home systems [19]. These systems consisted of the following:

- On the roof or in open places, solar panels are installed. Direct current (DC) electricity is produced by photovoltaic modules.
- For storing DC power generated from solar panels: Batteries.
- To prevent the additional charge of the battery: Charge controller.
- For changing the electricity produced by the system from dc to ac power: Inverter.

The following sketch shows a PV system that powers the AC load with the battery bank. The battery bank can also be directly attached to DC loads. Without a battery, it is also feasible to power an AC load, but this option would only be available during the daytime when solar radiation is adequate to produce the necessary electricity [27].

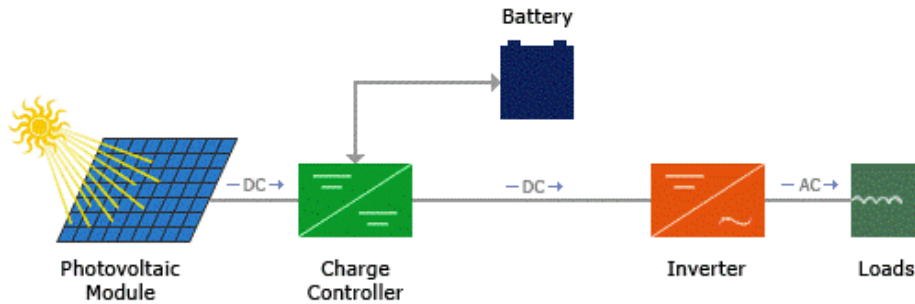

Fig. 2.13: Classical sketch of Stand-alone PV system [27].

2.3.2 Grid-Connected PV System:

For a grid-connected photovoltaic system: it will interact with the utility grid. The primary benefit of this system is its ability to receive electricity from the utility grid and, in the event that grid power is unavailable, to supplement it with solar energy. This grid attached systems are designed with batteries or without battery storage [27]:

- On the roof or in open places, solar panels are installed. Direct current (DC) electricity is produced by photovoltaic modules.
- For storing DC power generated from solar panels: Batteries.
- To prevent the additional charge of the battery: Charge controller.
- An inverter that has been specially created to convert DC electricity produced by solar panels to grid electricity (which is AC) at the grid voltage.

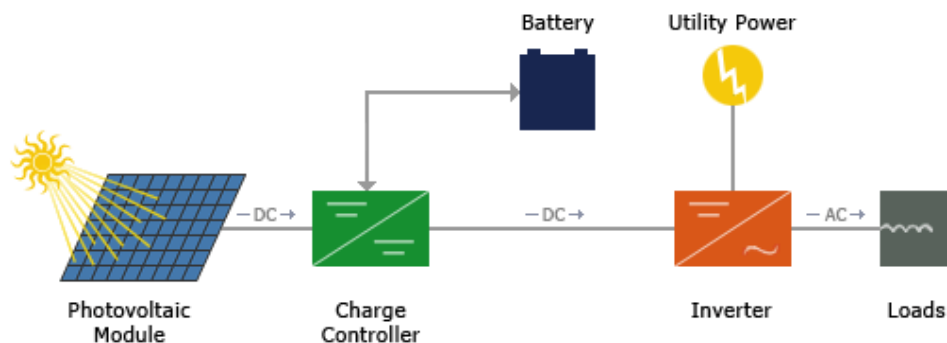

Fig. 2.14: Classical sketch of Grid Connected PV system [27].

CHAPTER 3

MAXIMUM POWER POINT TRACKING (MPPT)

3.1 Introduction:

Various types of MPPT techniques are used to get the highest efficiency under certain conditions from PV modules. This process is used to extract much feasible power from variable sources under various sunlight radiation and temperatures [7]- [28]. The parameters required to run the system at MPP are automatically measured by these procedures while simultaneously sensing the panel current, voltage, or both at MPP [2]. To track MPP (Maximum Power Point), a variety of techniques are applied. some of the most common techniques are [7]:

- ❖ Perturb & Observe (P&O)
- ❖ Incremental Conductance (IC)
- ❖ Parasitic Capacitance
- ❖ Constant Voltage
- ❖ Fuzzy Logic Control (FLC)
- ❖ Hybrid
- ❖ Neural Network (NN)
- ❖ Constant Current
- ❖ Fractional open circuit voltage (FOCV)
- ❖ Parasitic Capacitance
- ❖ Fractional short circuit current (FSCC) [7] - [29]- [3].

3.2 Perturb and Observe (P&O) Technique:

One of the most typical and widely used usual MPPT tracking technique is Perturb & Observe (P&O) [9]- [10]. P&O's fundamental assumption is to continuously perturb or change the operating point of the power converter and then to detect or sense the results [30].

- The 1st step of the P&O method is: to sense the PV panel's voltage and current values.
- The 2nd step: calculating of produced PV power.
- The 3rd step: calculating the variation in values of power and voltage.
- The 4th step: to verify whether power variation is positive or negative.

- The 5th step: to verify whether the voltage value i.e. the control variable has increased or decreased.
- The 6th step: if change in power is $\Delta V_{PV} > 0$ and voltage is $\Delta P_{PV} < 0$, duty cycle will decrease.
- The 7th step: if change in power is $\Delta P_{PV} < 0$ and voltage is $\Delta V_{PV} > 0$, duty cycle will increase [10].

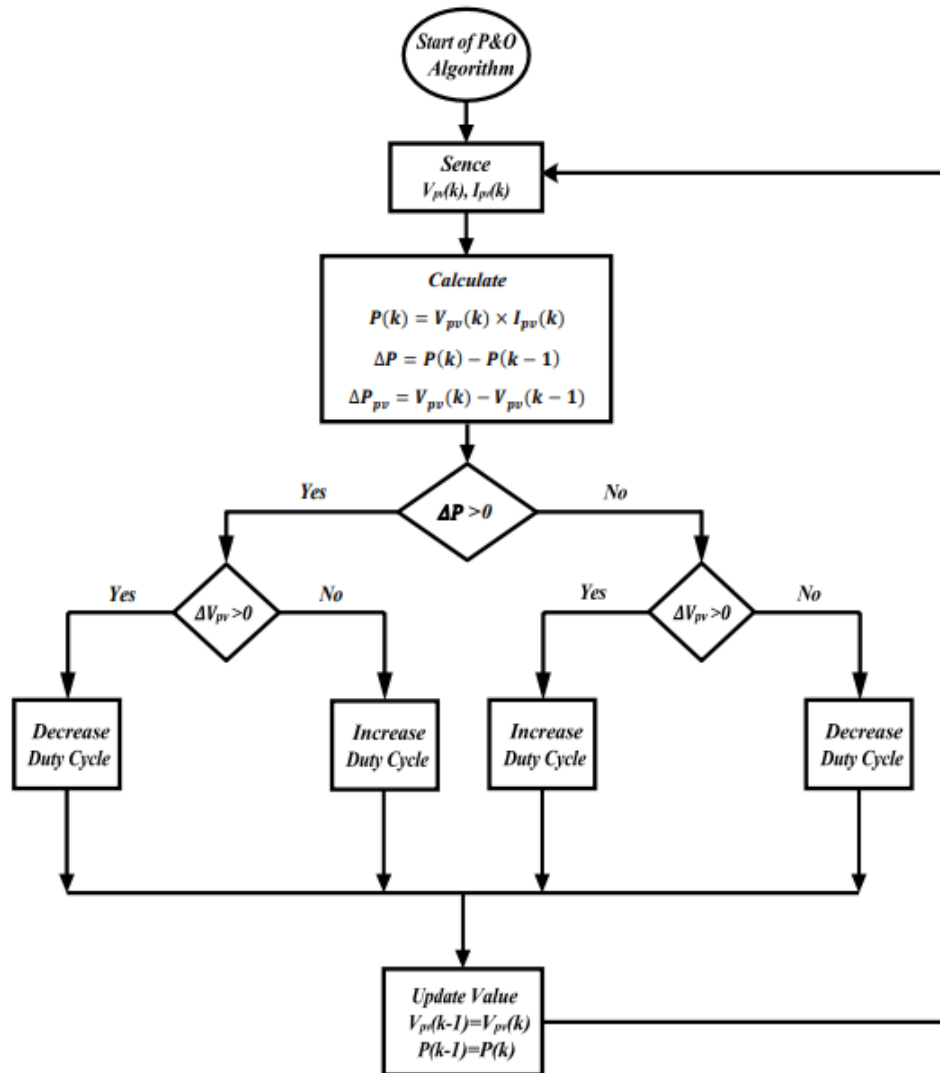

Fig. 3.1: Sketch of Perturb and Observe techniques [2].

The drawback of this method is: it is unable to track maximum power point (MPP) if there are rapid changes in parameters i.e. irradiance and temperature and one of the other drawback is the oscillation occurs at the point of MPP which results in oscillations in voltage and current at MPP level.

Table 3-1: Short Working Conception of P&O Techniques [2]- [9].

Condition	Change in Voltage/ Perturbation ΔV_{pv}	Change in Power ΔP_{pv}	Action of Next Perturbation
			Duty Cycle
1	$\Delta V_{pv} > 0$	$\Delta P_{pv} > 0$	Decrease
2	$\Delta V_{pv} < 0$	$\Delta P_{pv} > 0$	Increase
3	$\Delta V_{pv} > 0$	$\Delta P_{pv} < 0$	Increase
4	$\Delta V_{pv} < 0$	$\Delta P_{pv} < 0$	Decrease

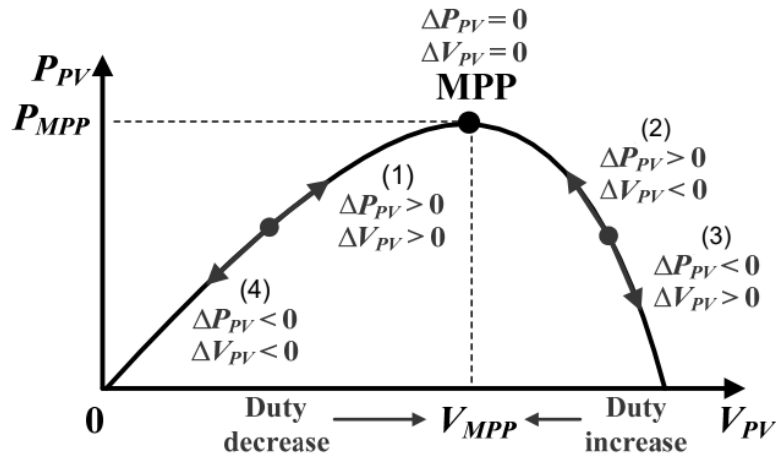

Fig. 3.2: Performance Rules of P&O techniques [31].

3.3 Incremental Conductance (IC) Technique:

Using the relationship between dI/dV and $-I/V$, MPP is determined in IC technique [32]. This method is based on the idea that the slope of the PV array power curve is zero at the MPP (Maximum Power Point). It is positive at the left of the MPP (Maximum Power Point) & at the right of the MPP it is negative [33]- [4]- [3] [34]. According to the statement:

$$\begin{aligned} dP/dV &= 0, & \text{at MPP} \\ dP/dV &> 0, & \text{left of MPP} \\ dP/dV &< 0, & \text{right of MPP.} \end{aligned}$$

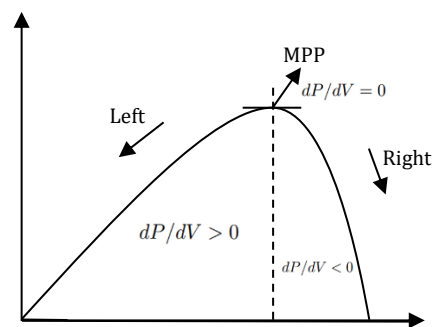

Fig. 3.3: Conceptual foundation of the IC techniques.

The MPP can also be tracked by comparing the instantaneous conductance (I/V) to the incremental conductance. Since [32]- [3]:

$$\begin{aligned} \frac{dP}{dV} &= \frac{d(V.I)}{dV} = I \frac{dV}{dV} + V \frac{dI}{dV} \\ &= I + V \frac{dI}{dV} \approx I + V \frac{\Delta I}{\Delta V} \end{aligned}$$

As a result, when we differentiate power with related to voltage, we obtain the following new condition [33]:

$$\begin{aligned} \frac{\Delta I}{\Delta V} &= -\frac{I}{V}, & \text{at MPP} \\ \frac{\Delta I}{\Delta V} &> -\frac{I}{V}, & \text{left of MPP} \\ \frac{\Delta I}{\Delta V} &< -\frac{I}{V}, & \text{right of MPP} \end{aligned}$$

Thus, the instantaneous conductance (I/V) and incremental conductance (I/V) can be compared to track the MPP, as demonstrated in the flowchart below. Where the PV array is compelled to work that is the reference voltage (V_{ref}). $V_{ref} = V_{MPP}$ at MPP. If the MPP is obtained, the PV array will continue to operate until change in ΔI , which directs changing of atmospheric conditions, and the changing of MPP. For tracking the newest MPP, the technique either decreases or increases V_{ref} [3]. The drawback of this method is: it is unable to track maximum power point (MPP) if there are rapid changes in parameters i.e. irradiance and temperature. The other drawback is: the oscillation occurs at the point of MPP which results in oscillations in voltage and current at MPP level [33].

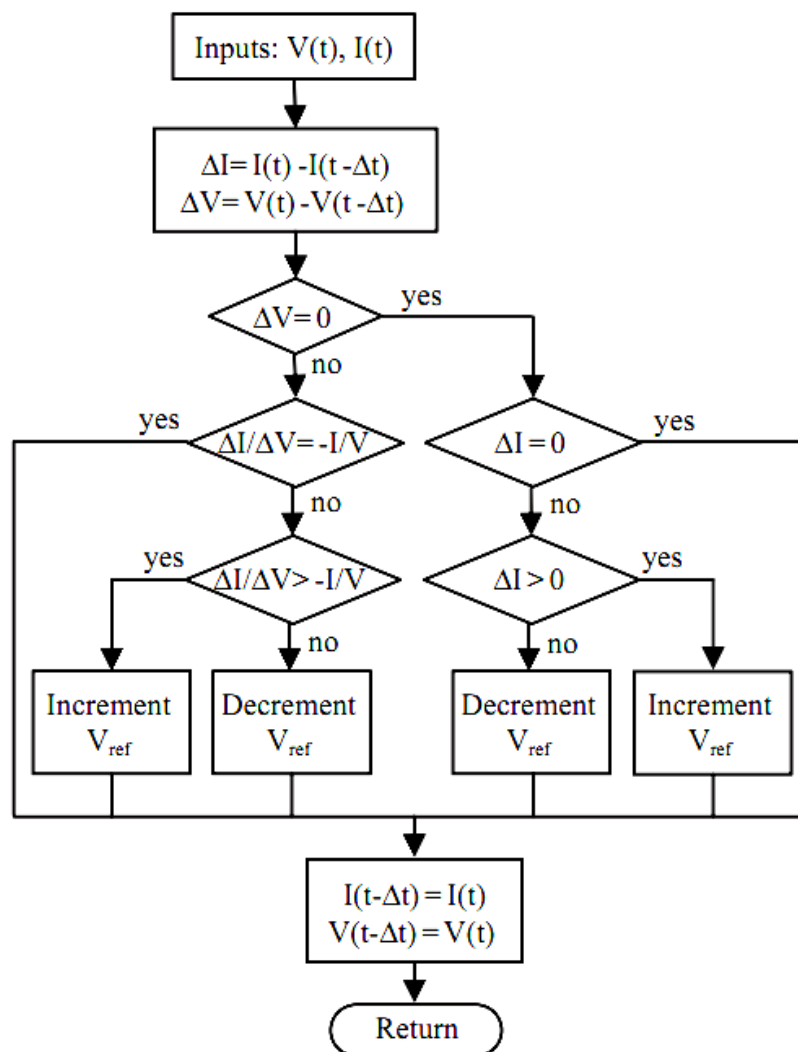

Fig. 3.4: Sketch of IC techniques [3]- [34]- [33].

3.4 Particle Swarm Optimization (PSO) Technique:

Eberhart and Kennedy first introduced Particle Swarm Optimization (PSO), It is an optimization strategy based on the social behavior of animals, such as the movement of organisms in a fish school or a flock of birds [35]. In other words, the PSO technique's basic idea was derived from how flocks of birds behave to solve issues with search and optimization [36]. Most optimization-related problems have been solved using the PSO. Its central concept is to iteratively move a set of particles toward the optimal position inside a specified search space in order to optimize an issue. Position update and velocity update are the two premier operators in the PSO formation.

The fundamental PSO method is shown in Figure 3.5, and it consists of four major steps for each iteration of the process.

- The best position that each population particle has thus far attained, known as pBest, is assessed for each particle. If the present position is better than the prior position, the particle position is changed; otherwise, the previous position is retained.
- Consider gBest, it is the best position of the particles in the entire population.
- Utilize pBest and gBest to update the velocity. The new valocity is calculated using,

$$v_i^{t+1} = v_i^t + \alpha \varepsilon_1 [pBest_i^t - x_i^t] + \beta \varepsilon_2 [gBest^t - x_i^t]$$

where i = particle index, t = time index, ε_1 and ε_2 are two random vectors in range [0, 1] and α and β are positive constants.

- Revise the particle position. The updated position of the particle is determined by:

$$x_i^{t+1} = x_i^t + v_i^{t+1}$$

The population's particles are in their preferred places because these four processes are continued until they satisfy a stopping requirement [35].

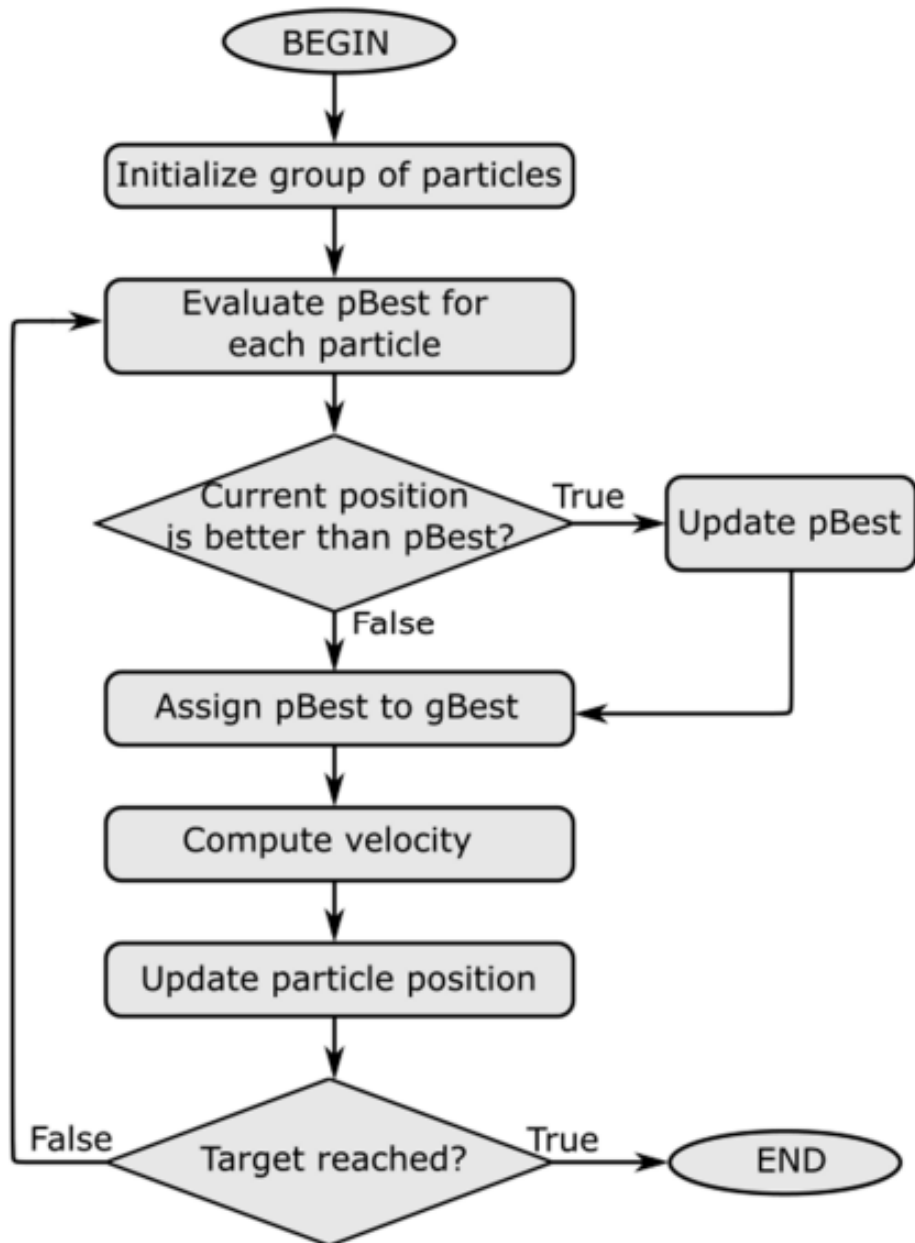

Fig. 3.5: Sketch of PSO techniques [35].

Table 3-2: Features of various MPPT techniques [3] [35].

MPPT techniques	Convergence speed	Complexity	Periodic tuning
Perturb & observe	Varies	Low	No
Incremental conductance	Varies	Medium	No
Fractional open circuit voltage	Medium	Low	Yes
Fractional short circuit current	Medium	Medium	Yes
Fuzzy logic control	Fast	High	Yes
Neural network	Fast	High	Yes

3.5 Some other MPPT Techniques:

3.5.1 Fractional Open-Circuit Voltage (FOCV):

Using this method, the empirical relationship displayed below can be calculated:

$$V_{mpp} \approx K_{oc} V_{oc}$$

The value of K_{oc} is observed to range between 0.78 and 0.92. By observing the PV system under a variety of solar radiation and temperature conditions, K_{oc} can be estimated. In this procedure, the PV system is briefly open-circuited at the load end to measure V_{oc} before calculating V_{mpp} using the top equation. Performing this process again V_{oc} is regularly sampled every few seconds, updating the V_{mpp} value [38].

3.5.2 Fractional Short Circuit Current (FSCC):

It is predicated on the idea that the short circuit current and the operating current of a PV array have a linear relationship. The technique can track the MPP quickly in rapidly changing atmospheric circumstances, but the hardware for current-based MPPT is made more difficult by the requirement for online short-circuit current measurements [37].

3.5.3 Fuzzy Logic Control (FLC):

Fuzzy logic was introduced by Lotfi Zadeh. Although this method is effective and precise, it is extremely complicated and calls for a lot of processing. Fuzzy logic makes it easier to use uncertain inputs. As a result, it does not need a precise mathematical model and is capable of managing the complexity brought on by nonlinearities and uncertainty [37].

3.5.4 Neural Network (NN):

For training, this method needs a large amount of data. Datasets for a neural network-based method are created by taking into account direct influence state variables (solar insolation, junction temperature, and dynamics of the charging voltage, in the case of a battery) [37].

CHAPTER 4

DC-DC BOOST CONVERTER

4.1 Boost Converter:

The step-up converter is another name for the boost converter. The name refers that it often converts low input voltage to high output voltage, working similarly to a buck converter in reverse [39]. To change an unregulated dc voltage into a regulated dc output voltage, DC-DC converters can be utilized as switching mode regulators. BJT, MOSFET, or IGBT are frequently used as switching devices to achieve regulation, which is typically accomplished via PWM at a fixed frequency [40]. It utilizes as the interface among loads and PV panels. PV output is used as the input, and the circuit is changed to produce the desired output while being controlled to maintain output voltage and steady current [41].

For all situations of temperature and solar irradiance changes, the boost converter raises the voltage to maintain the maximum output voltage constant [42]. Figure 4.1 displays a simple boost converter.

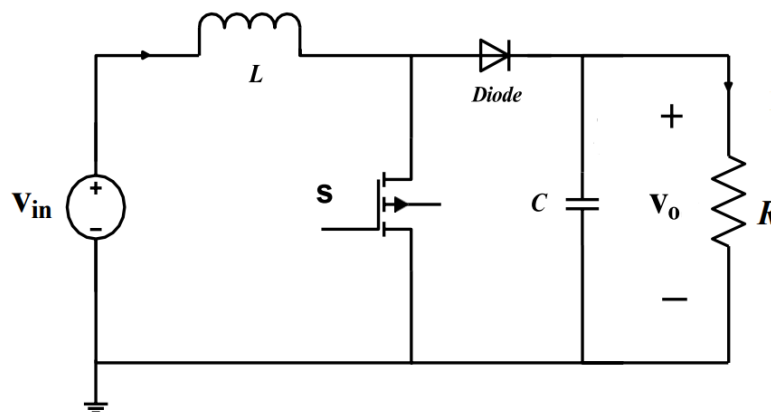

Fig. 4.1: Sketch of a simple boost converter.

The average voltage across the inductor throughout a whole period is zero for steady state activity. Input voltage V_{in} .

$$V_{in} * t_{on} - (V_o - V_{in}) t_{off} = 0 \quad \dots\dots\dots (1)$$

Therefore,

$$V_{in} * D * T = (V_o - V_{in}) (1 - D) T \quad \dots\dots\dots (2)$$

$$V_o / V_{in} = 1 / (1 - D) \quad \dots\dots\dots (3)$$

We may explore the performance of converters that use solar energy as input by forming this circuit. Without the need of a transformer, a boost regulator can raise the voltage. It has a high efficiency because of a single switch. The input current is continual. In equation (3), the output voltage is extremely sensitive to variations in duty cycle D . By a factor of $(D-1)$, the average output current is lower than the average inductor current and the filter capacitor's rms current would be significantly higher.

Equation (4) provides the value of inductance L from the analysis of the inductor current ripple while the boost converter is operating in continuous conduction mode (CCM).

$$L_{min} = (1 - D)^2 * D * R / 2 * f \quad \dots\dots\dots (4)$$

The output RC circuit receives a discontinuous supply of current. In order to reduce the output voltage ripple, a large filter capacitor is employed. When the diode D is off, the filter capacitor must deliver the output dc current to the load.

The minimum value of the filter capacitance which results in voltage ripple ($V_r = \Delta V_o / V_o$) is given by Equation (5).

$$C_{min} = D / R * f * V_r \quad \dots\dots\dots (5)$$

The boost inductor's current increases linearly and the diode is off while the switch S is in the ON state. The inductor is charged from the input voltage source V_{in} and the capacitor discharges across the load. The inductor's energy is released into the output RC circuit via the diode when the switch S is in the OFF position. The load voltage V_o is arranged as the sum of input voltage and inductor voltage [42]- [43].

4.2 Design of DC-DC Boost Converter with the Suggested System:

In this study, the solar panel and the load connected by a DC-DC converter, which is a crucial component. The below figure demonstrates the connection between the boost converter topology and the remainder of the solar PV system. The switching transistor (IGBT), which switches the boost converter, will then have its duty cycle changed accordingly. Typically, the Controller monitors the MPP by sensing the panel current and voltage and measuring the power [2].

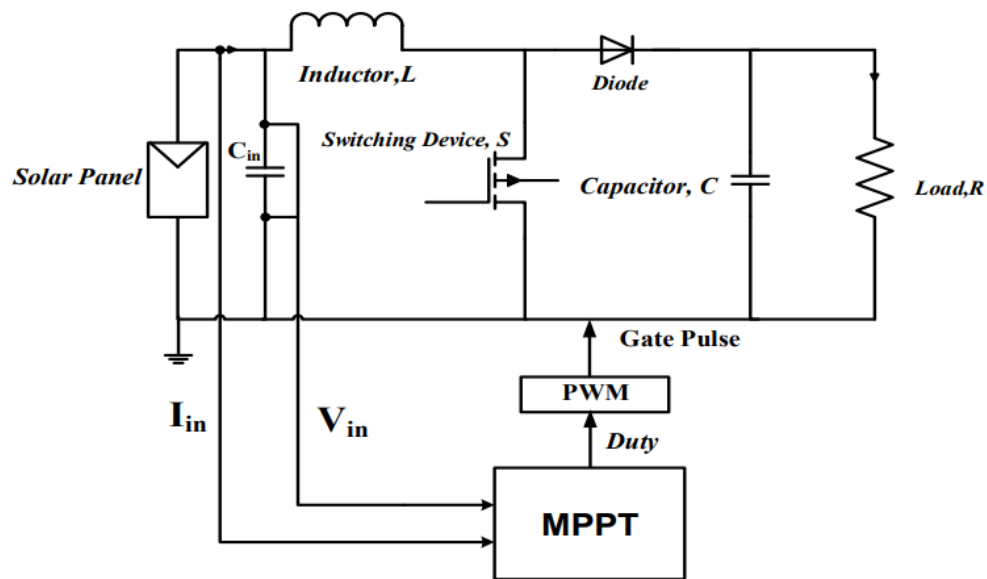

Fig. 4.2: Sketch of Boost Converter with MPPT Controller & Solar Panel [2].

In this study, the suggested PSO MPPT technique has been implemented on a DC-DC boost converter and compared to the P&O and IC techniques in terms performance.

CHAPTER 5

SYSTEM SIMULATION & PERFORMANCE ANALYSIS

5.1 Introduction:

This simulation's primary goal is to show how the system operates in the MATLAB environment and examine the simulated results. In this chapter, we'll separately simulate our suggested systems and discuss the findings and for the simulation we'll use MATLAB/SIMULINK software.

5.2 Exhaustive Simulink PV System

5.2.1 Perturb and Observe (P&O) Techniques:

In chapter 3, it has already been discussed how this technique works. Here in this Simulink model a solar array, a boost converter and P&O technique are used. In this process, the PV's input voltage & current are first sensed and the input power is calculated. According to the below structure we can see that, the P&O MPPT block are supplied with two input i.e. PV input's voltage [V_{pv}] and PV input's current [I_{pv}]. The input voltage & input current of PV and their product means input power is connected to the displays and scope is utilized to get their input waveforms. The output is connected to a voltmeter and a current measurement device. The displays are likewise tied to output current, output voltage, and output power. Additionally, a scope is employed to display the efficiency curve and the powergui is employed to simulate the proposed model.

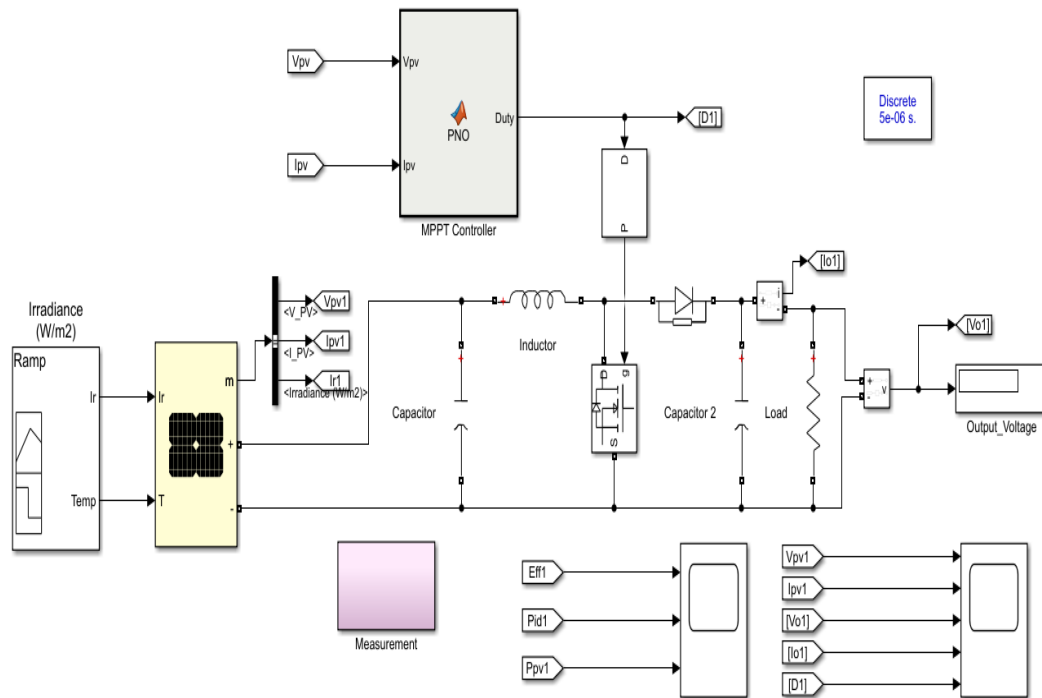

Fig. 5.1: P&O technique Simulink model with dc-dc boost converter.

5.2.2 Incremental Conductance (IC) Techniques:

How this technique works we discussed that in chapter 3. The following phases serve as the foundation for the controller design.

$$\begin{aligned} \frac{dP}{dV} = 0 &\Rightarrow \frac{\Delta I}{\Delta V} = -\frac{I}{V}, && \text{at MPP} \\ \frac{dP}{dV} > 0 &\Rightarrow \frac{\Delta I}{\Delta V} > -\frac{I}{V}, && \text{left of MPP} \\ \frac{dP}{dV} < 0 &\Rightarrow \frac{\Delta I}{\Delta V} < -\frac{I}{V}, && \text{right of MPP} \end{aligned}$$

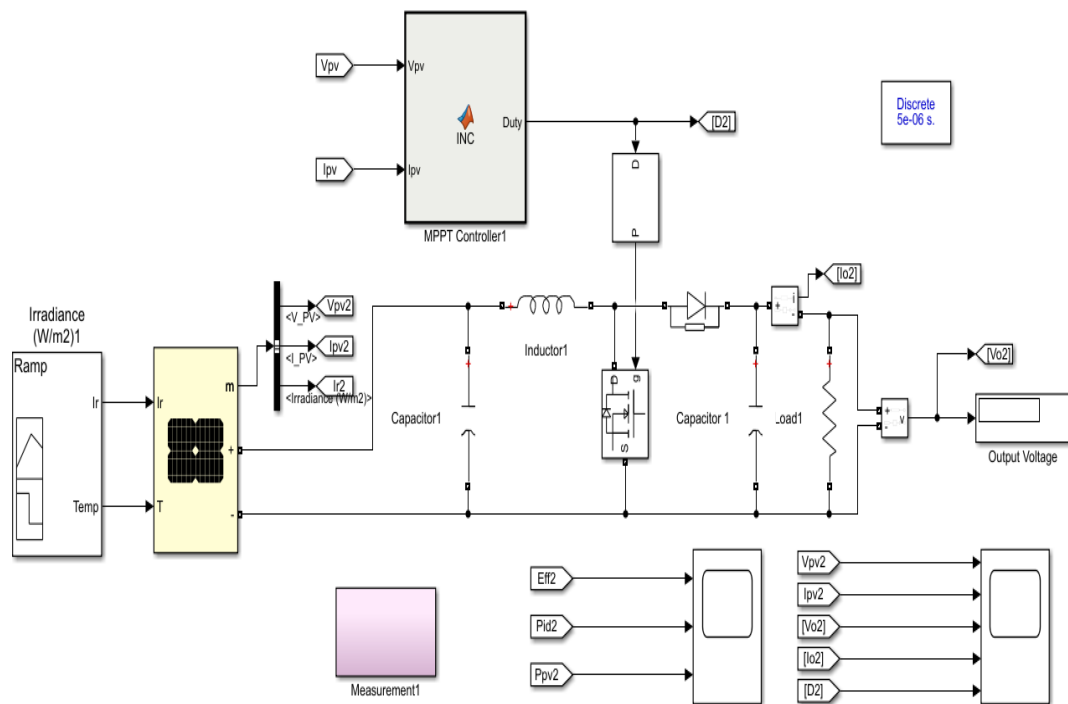

Fig. 5.2: IC technique Simulink model with dc-dc boost converter.

5.2.3 Particle Swarm Optimization (PSO) Techniques:

PSO technique's basic idea was derived from how flocks of birds behave to solve issues with search and optimization [36]. It is a method for stochastically optimizing systems that are based on the movement and judgment of swarms. In PSO, the concept of social interaction is used for solving a problem. Although this model and the one before have similarities but the methods for solving the problem are different.

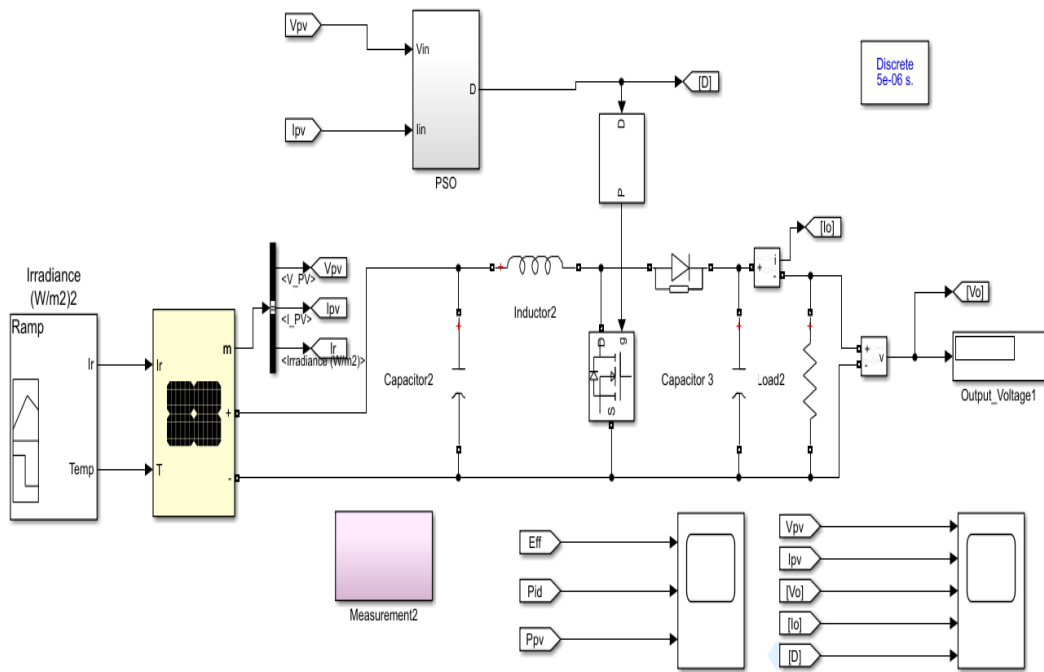

Fig. 5.3: PSO technique Simulink model with dc-dc boost converter.

5.1 Results of simulation:

The MATLAB/Simulink software is used to simulate these techniques. And it is possible to acquire the input and output profiles for Power, Voltage, and Current. Fig. 5.4 shows the output power profile for the P&O method.

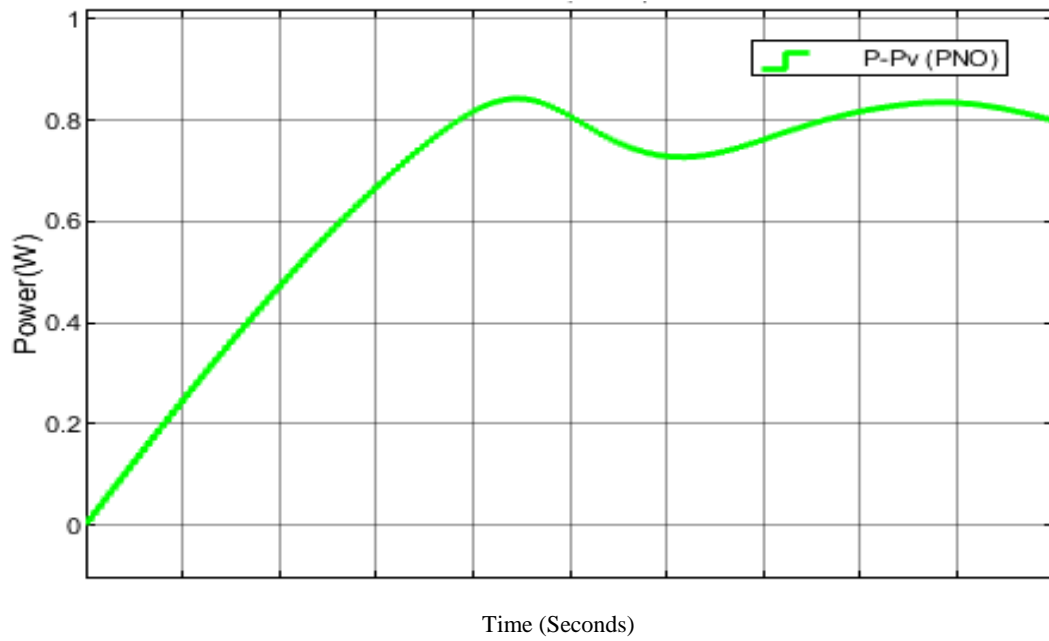

Fig. 5.4: Output power curve (P&O technique).

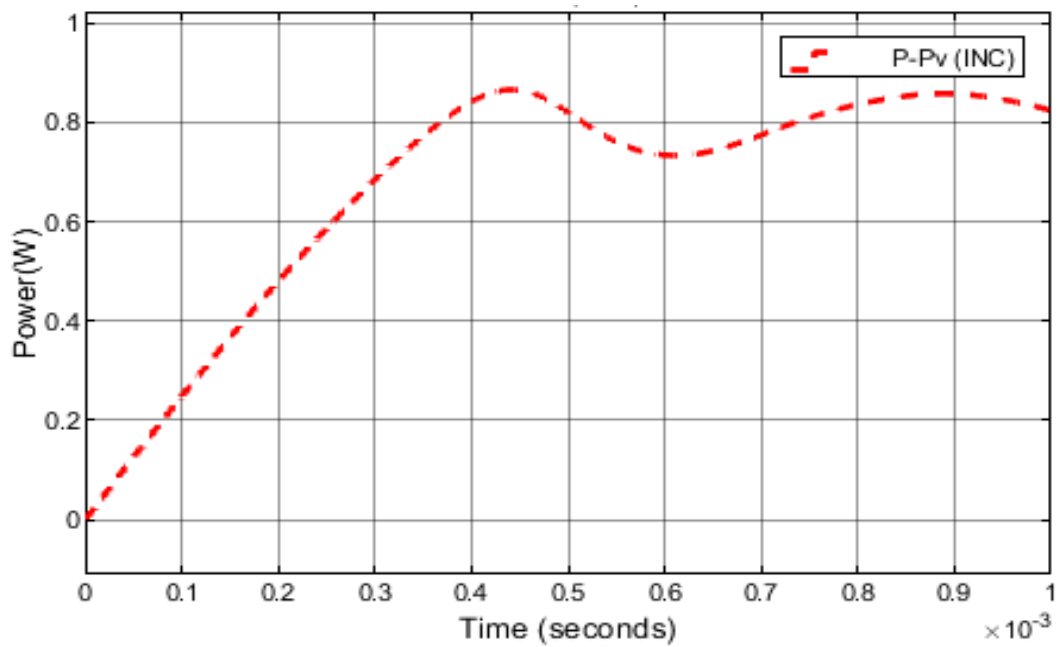

Fig. 5.5: Output power curve (IC technique).

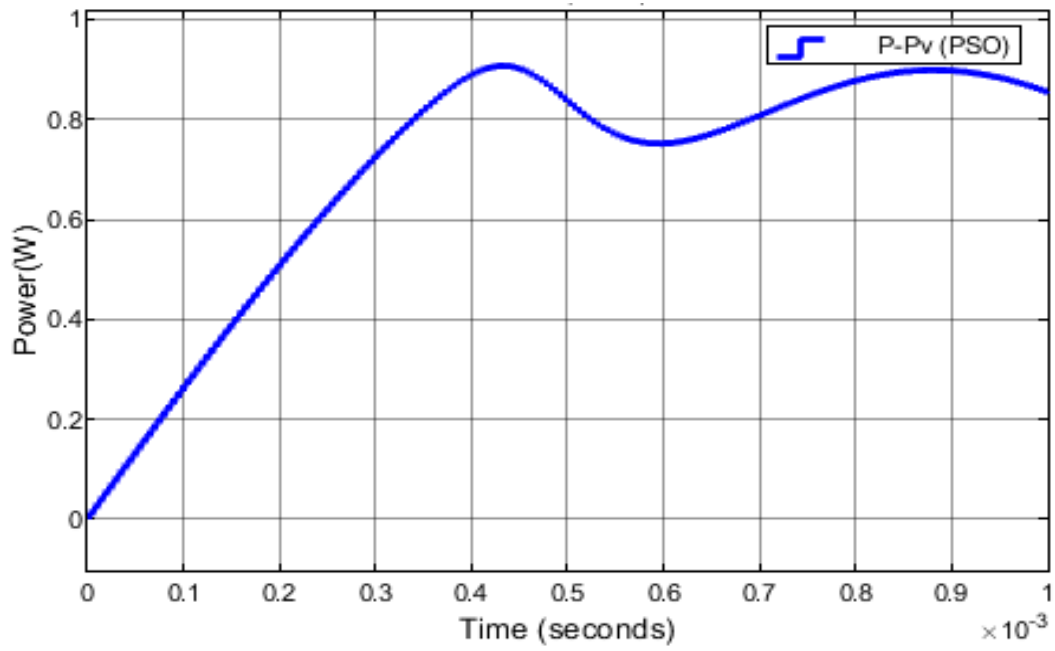

Fig. 5.6: Output power curve (PSO technique).

In terms of output power, the PSO technique extracts more power than the other two techniques, which we can see by a comparison of the output power curves for these three techniques from the simulation results here. The PSO technique is more efficient than the other two techniques.

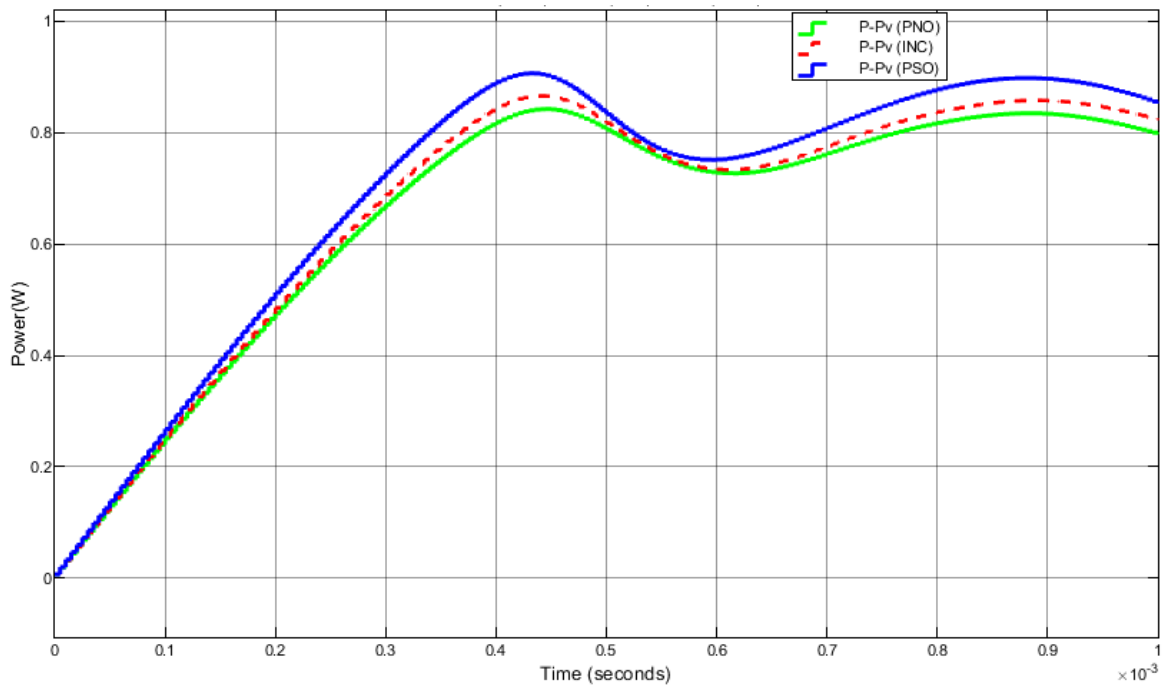

Fig. 5.7: Comparison curve of output power (P&O, INC, and PSO)

In this simulation work, the PSO technique with DC-DC boost converter has been used as per the proposed system and its performance has been compared with the other two techniques (IC and P&O). According to the simulation results, the suggested PSO technique is simple and superior to the P&O and IC techniques. Moreover, from here we see that the PSO techniques efficiency is higher than the other two techniques.

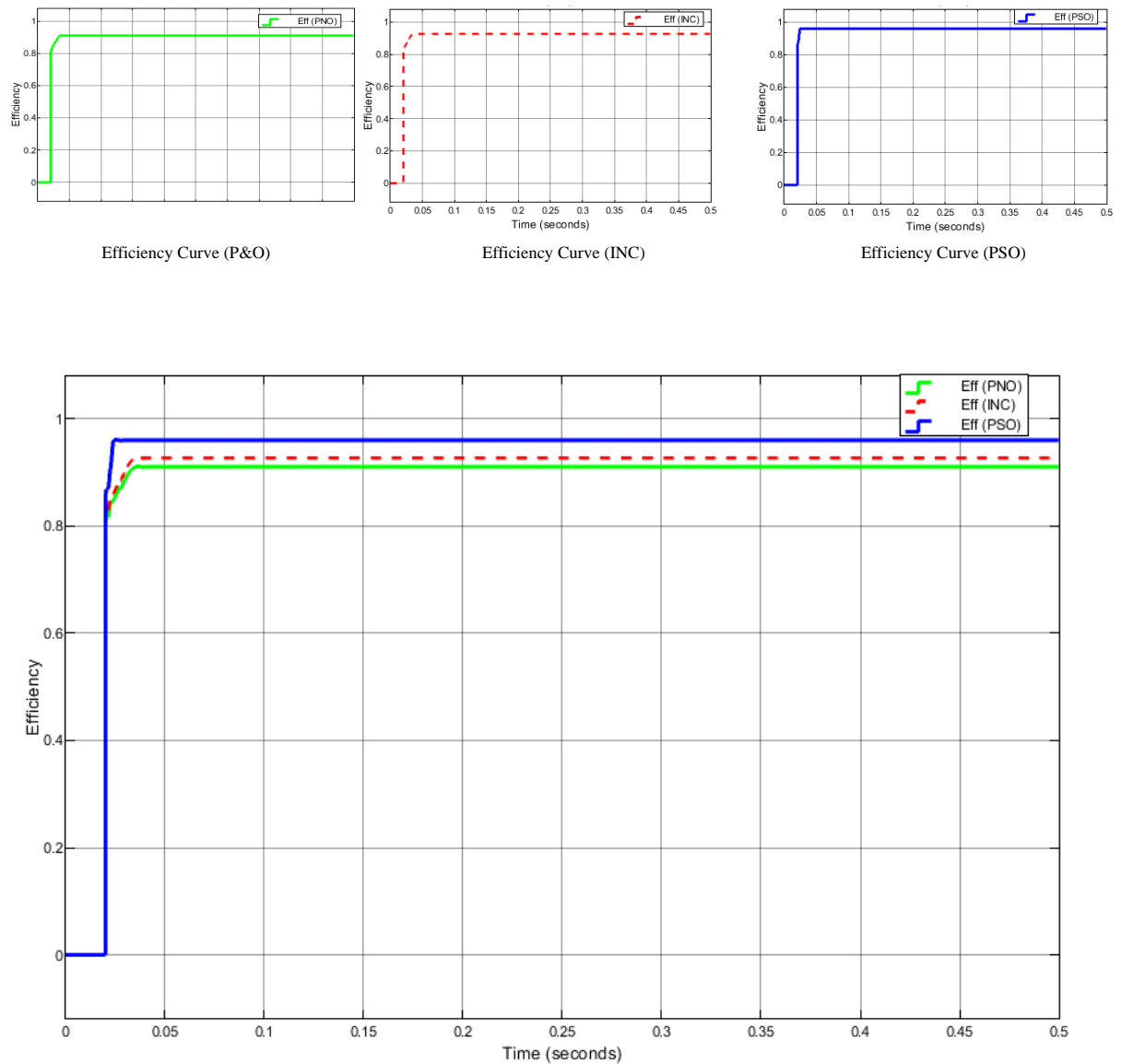

Fig. 5.8: Comparison curve of efficiency (P&O, INC, PSO).

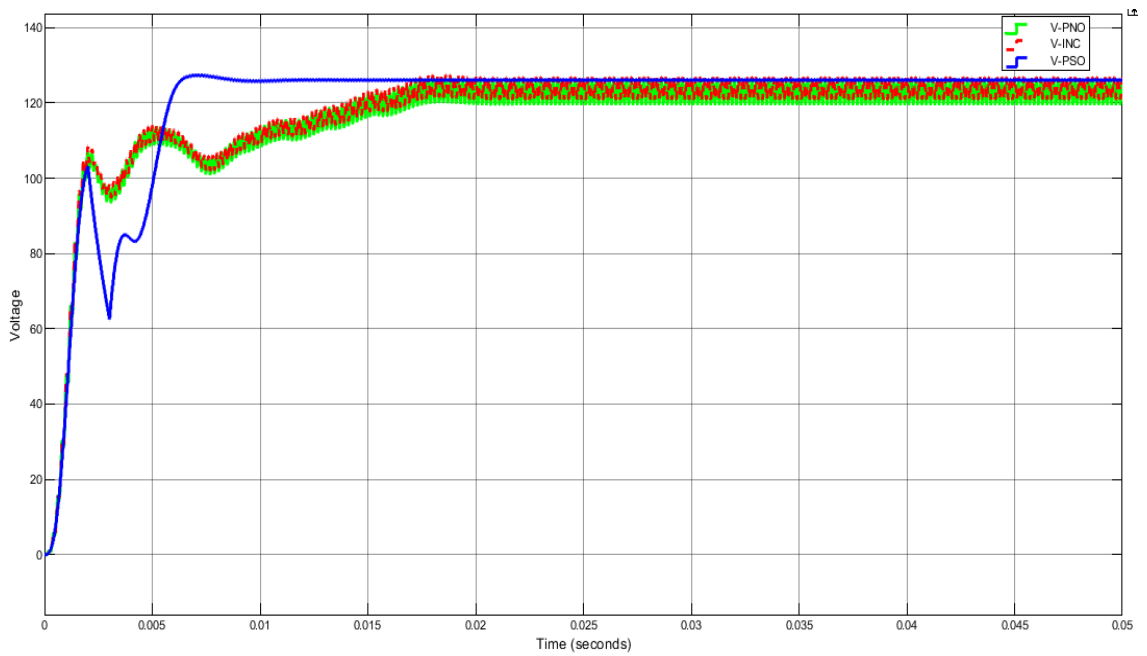
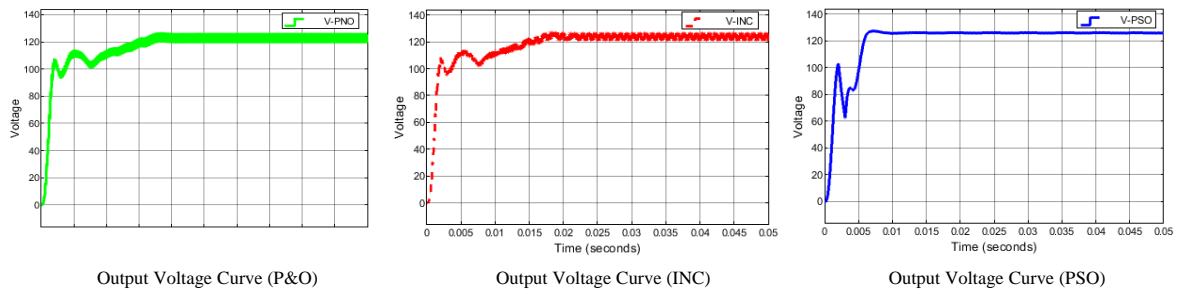
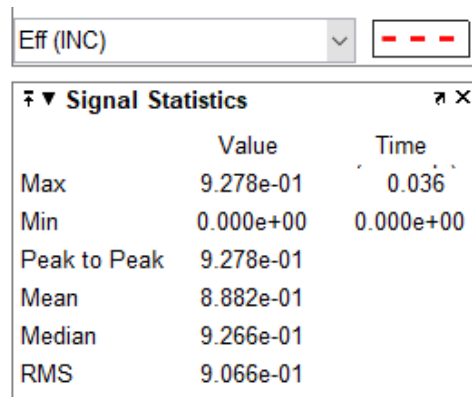
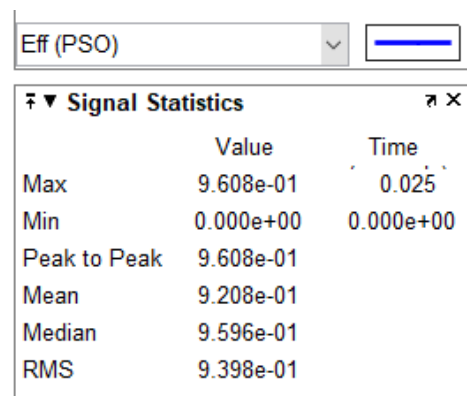
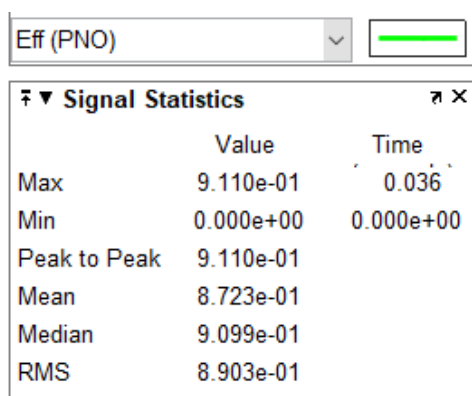

Fig. 5.9: Comparison curve of output voltage (P&O, INC, PSO).

Table 5-1: Efficiency comparison between P&O, IC & PSO MPPT methods:

MPPT Methods	Maximum Efficiency (%)	Mean Efficiency (%)
P&O	91.10	87.23
IC	92.78	88.82
PSO	96.08	92.08



CHAPTER 6

CONCLUSION AND FUTURE WORKS

6.1 Conclusion:

The above study evaluated the tracking effectiveness, and efficacy of MPPT simulations for PV systems utilizing P&O, IC, and PSO techniques. According to the simulation results, the PSO technique was able to track the MPP accurately in all conditions and has benefits over other strategies such as a very high tracking efficiency, simple structure, easy implementation and a very quick convergence speed to the desired solution.

6.2 Future Works:

In this study, several MPPT techniques are discussed. In subsequent research, someone might investigate one of these MPPT techniques with a boost converter to assess their efficacy and compare it to the suggested technique. Also, one can develop and integrate a charge controller for the battery with the proposed system.

REFERENCES

- [1] K. Ranjan and N. Kumar, "Modelling and Simulation of Perturb and Observe Algorithm on Solar PV System using Different Converters in MATLAB/Simulink," *1st IEEE International Conference on Power Electronics. Intelligent Control and Energy Systems (ICPEICES-2016)*, pp. 1-6, 2016.
- [2] M. H. Reza and M. A. Shobug, "Efficiency Evaluation of P&O MPPT Technique used for Maximum Power Extraction from Solar Photovoltaic System," *2020 IEEE Region 10 Symposium (TENSymp)*, 5-7 June 2020.
- [3] T. Easram and P. L. Chapman, "Comparison of Photovoltaic Array Maximum Power Point Tracking Techniques," *IEEE Transactions on Energy Conversion*, vol. 22, no. 2, pp. 439-449, June 2007.
- [4] D. William Christopher, "Comparative Study of P&O and InC MPPT Algorithms," *American Journal of Engineering Research (AJER)*, vol. 02, no. 12, pp. 402-408, 2013.
- [5] Z. Cheng, H. Zhou and H. Yang, "Research on MPPT control of PV system based on PSO algorithm," *2010 Chinese Control and Decision Conference*, pp. 887-892, 1 July 2010.
- [6] S. Thakran, J. Singh and P. R. Garg, "Implementation of P&O Algorithm for MPPT in SPV System," *2018 International Conference on Power Energy, Environment and Intelligent Control (PEEIC)*, pp. 242-245, 13-14 April 2018.
- [7] K. Jain, P. M. Gupta and D. A. K. Bohre, "Implementation and Comparative Analysis of P&O and INC MPPT Method for PV System," *2018 8th IEEE India International Conference on Power Electronics (IICPE)*, 2018.
- [8] D. R. Garg, D. A. Singh and S. Gupta, "PV Cell Models and Dynamic Simulation of MPPT Trackers in MATLAB," *2014 International Conference on Computing for Sustainable Global Development (INDIACom)*, pp. 6-12, 2014.
- [9] S. Khan and R. A. Qazi, "Implementation of an Efficient MPPT Algorithm for Photovoltaic System," *2019 2nd International Conference on Computing, Mathematics and Engineering Technologies (iCoMET)*, 2019.
- [10] A. Singh and S. S.L., "MATLAB / SIMULINK Simulation of PV System Based on MPPT in Variable Irradiance with EV Battery as Load," *2017 IEEE International Conference on Computational Intelligence and Computing Research (ICIC)*, 2017.
- [11] "Solar Cell," [Online]. Available: <https://www.sciencedirect.com/topics/chemistry/solar-cell>. [Accessed 17 January 2023].
- [12] "How a Solar Cell Works," [Online]. Available: <https://www.acs.org/education/resources/highschool/chemmatters/past-issues/archive-2013-2014/how-a-solar-cell-works.html>. [Accessed 17 January 2023].
- [13] "Short-Circuit Current," [Online]. Available: <https://www.pveducation.org/pvcdrom/solar-cell-operation/short-circuit-current>. [Accessed 17 January 2023].
- [14] "Characteristics of a Solar Cell and Parameters of a Solar Cell," [Online]. Available: <https://www.electrical4u.com/characteristics-and-parameters-of-a-solar-cell/>. [Accessed 17 January 2017].
- [15] "Open-Circuit Voltage," [Online]. Available: <https://www.pveducation.org/pvcdrom/solar-cell-operation/open-circuit-voltage>. [Accessed 17 January 2023].
- [16] R. Mayfield, "Photovoltaic Design & Installation For Dummies," John Wiley & Sons, 2019.
- [17] "Characteristics of a Solar Cell and Parameters of a Solar Cell," [Online]. Available: <https://www.electrical4u.com/characteristics-and-parameters-of-a-solar-cell/>. [Accessed 18 January 2023].
- [18] "Photovoltaic (PV) Cell: Characteristics and Parameters," [Online]. Available: <https://electricala2z.com/renewable-energy/photovoltaic-pv-cell-characteristics-parameters/>. [Accessed 17 January 2023].

- [19] P. Mohanty, T. Muneer and M. Kolhe, Eds., "Solar Photovoltaic System Applications: A Guidebook for Off-Grid Electrification," illustrated ed., Springer, 2015.
- [20] R. Foster, M. Ghassemi and A. Cota, "Solar Energy: Renewable Energy and the Environment," CRC Press, 2009.
- [21] M. R. Patel, "Wind and Solar Power Systems," CRC Press, 1999.
- [22] "Different Types of Solar Cells – PV Cells & their Efficiencies," 26 April 2021. [Online]. Available: <https://solarsena.com/different-types-solar-cells-efficiencies/>. [Accessed 19 January 2023].
- [23] "Solar Cell Materials - An Overview of Solar Cell Materials," 30 March 2008. [Online]. Available: <https://www.azocleantech.com/article.aspx?ArticleID=64>. [Accessed 19 January 2023].
- [24] "Components of a Solar Photo Voltaic Panel," 9 June 2018. [Online]. Available: <https://www.ulaginoli.com/product-introduction-series/components-of-a-solar-photo-voltaic-panel/>. [Accessed 20 January 2023].
- [25] P. A. Lynn , "Electricity from Sunlight: An Introduction to Photovoltaics," John Wiley & Sons, 2010.
- [26] "Types of PV Systems," [Online]. Available: <https://energyresearch.ucf.edu/consumer/solar-technologies/solar-electricity-basics/types-of-pv-systems/#:~:text=Photovoltaic%20power%20systems%20are%20generally%20classified%20according%20to,are%20grid-connected%20or%20utility-interactive%20systems%20and>. [Accessed 20 January 2023].
- [27] "Solar Photovoltaic Systems," [Online]. Available: <http://www.synergyenviron.com/resources/solar-photovoltaic-systems>. [Accessed 20 January 2023].
- [28] R. B. A. Koad and A. F. Zobaa, "Comparative study of five maximum power point tracking techniques," *International Journal on Energy Conversion (IRECON)*, January 2014.
- [29] A. O. Baba, G. Liu and X. Chen , "Classification and Evaluation Review of Maximum Power Point Tracking Methods," *Sustainable Futures 2 (2020) 100020*, January 2020.
- [30] N. Narasimhulu, D. A. Basha, K. Swathi and D. R. Ramachandra, "Optimal Control Strategy for a Solar Photovoltaic Power System using MATLAB Simulink," *International Research Journal of Engineering and Technology (IRJET)*, vol. 4, no. 12, pp. 1443-1448, 2017.
- [31] J.-. J. Yun and H.-. S. Lee , "Advanced MPPT Algorithm for Distributed Photovoltaic Systems," *Energies 2019, 12, 3576*, pp. 1-17.
- [32] R. I. Putri, S. Wibowo and M. Rifa'i, "Maximum power point tracking for photovoltaic using incremental conductance method," *2nd International Conference on Sustainable Energy Engineering and Application, ICSEEA 2014*, vol. 68, pp. 22-30, April 2015.
- [33] R. N. Tripathi, A. Singh and M. Badoni, "A MATLAB-simulink-based solar photovoltaic array (SPVA) module with MPPT," *2013 International Conference on Emerging Trends in Communication, Control, Signal Processing and Computing Applications (C2SPCA)*, October 2013.
- [34] A. Rezvan, M. Izadbakhsh, S. Mirsaeidi and S. vafaei, "COMPARISON BETWEEN ANN-GA AND INCREMENTAL CONDUCTANCE CONTROL FOR SOLAR PV SYSTEM IN THE GRID CONNECTED MODE," *Sci.Int.(Lahore)*,27(3),1931-1937,2015, pp. 1931-1937.
- [35] L. M. Le, H.-B. Ly, B. T. Pham, V. M. Le, T. A. Pham , D.-H. Nguyen, X.-T. Tran and T.-T. Le, "Hybrid Artificial Intelligence Approaches for Predicting Buckling Damage of Steel Columns Under Axial Compression," *Materials 2019,12, 1670*, pp. 1-18, May 2019.
- [36] H. Chaieb and A. SAKLY, "Comparison between P&O and P.S.O Methods Based MPPT Algorithm for Photovoltaic Systems," *16th international conference on Sciences and Techniques of Automatic control & computer engineering - STA'2015*, pp. 694-699, 21-23 December 2015.

- [37] I. Vajpai and M. Kachhwaha, "COMPARISON OF MPPT TECHNIQUES FOR PV SYSTEMS," *National Conference on ADVANCES IN TECHNOLOGY AND APPLIED SCIENCESAt: Jodhpur*, March 2014.
- [38] B. Subudhi and R. Pradhan, "A Comparative Study on Maximum Power Point Tracking Techniques for Photovoltaic Power Systems," *IEEE TRANSACTIONS ON SUSTAINABLE ENERGY*, vol. 4, no. 1, pp. 89-98, January 2013.
- [39] A. K. Yadav, S. Thirumaliah and G. Haritha, "Comparison of MPPT Algorithms for DC-DC Converters Based PV Systems," *International Journal of Advanced Research in Electrical, Electronics and Instrumentation Engineering*, vol. 1, no. 1, pp. 18-23, July 2012.
- [40] S. selvan, H. and I. , "Modeling and Performance Analysis of New Cuk Converter Topology for Photovoltaic Applications," *Journal of Energy Technologies and Policy*, vol. 4, no. 1, pp. 53-60, January 2014.
- [41] A. M. Zina, "Study and Design of Stand-Alone Photovoltaic System to Maximizing Efficiency Solar Power Using Fuzzy Logic Algorithm," *International Journal of Computer Science Trends and Technology (IJCST)*, vol. 6, no. 5, pp. 92-94, 2018.
- [42] T. Chaitanya, C. Saibabu and J. S. Kumari, "Modeling and Simulation of PV Array and its Performance Enhancement Using MPPT (P&O) Technique," *T.Chaitanya et al, International Journal of Computer Science & Communication Networks*, vol. 1, pp. 9-16, 2011.
- [43] S. Sholapur, K. R. Mohan and T. R. Narsimhegowda, "Boost Converter Topology for PV System with Perturb And Observe MPPT Algorithm," *IOSR Journal of Electrical and Electronics Engineering (IOSR-JEEE)*, vol. 9, no. 4, pp. 50-56, 2014.