



Daffodil *International* **University**

Project (Thesis)

Commissioning of newly installed modern Rapier loom.

Course Title: Project (Thesis)

Course Code: TE4214

Submitted By

<u>Student Name</u>	<u>Student ID</u>
Sabbir Hossain	192-23-5676
Debasish Sarker	192-23-5696
Tafsir Ahmed Toha	192-23-5667

Academic Supervisor

Dr. Md. Mahbubul Haque

Professor & Program Director, M.Sc

Department of Textile Engineering

This thesis is submitted in partial fulfillment of the requirements of the degree of
Bachelor of Science in Textile Engineering.

Advanced in Fabric Manufacturing Technology.

Spring-2023

Department of Textile Engineering

Faculty of Engineering

Daffodil International University



Daffodil
International
University

Faculty of Engineering
Department of Textile Engineering

APPROVAL SHEET

This research entitled “Commissioning of newly installed modern Ravier loom.” Is prepared and submitted by Sabbir Hossain (ID: 192-23-5676), Debasish Sarker (ID: 192-23-5696) and Tafsir Ahmed Toha (ID: 192-23-5667) in partial fulfilment of the requirement of the degree of **Bachelor of Science in Textile Engineering** has been examined and hereby recommended for approval and acceptance.

Supervised By

Dr. Md. Mahbubul Haque

Professor & Program Director, M.Sc

Department of Textile Engineering

Faculty of Engineering

Daffodil International University



ACKNOWLEDGEMENT

First, we would like to give Allah our sincere gratitude and thanks for enabling us to successfully complete this report with His help.

We are appreciative of and send our best wishes to Professor Dr. Md. Mahbulul Haque. Daffodil International University, Faculty of Engineering, Department of TE. Our decision to complete this thesis was inspired by our supervisor's extensive knowledge and great interest in the field's advancement. This project was made possible by his never-ending patience, academic leadership, constant encouragement, constant and energetic supervision, constructive criticism, invaluable counsel, reading numerous subpar drafts and fixing them at every stage. We would like to extend our sincere gratitude to the other faculty members of the Daffodil International University's TE department.

We also want to express our gratitude to Shakhawat Hossain Rizvi, Executive Director of Universal Denims Ltd. for allowing us to conduct our research in this reputable facility. We would like to give our deepest gratitude to SM Noor A. Alam Siddique, Assistant General Manager-Administration, Human Resources, Universal Denims Ltd.

Also, we appreciate our supervisors, technicians, operators, and all other employees of the Universal Denims Ltd. for their kind and helpful assistance.

Last but not least, we would want to show our gratitude to my cherished parents and friends for their moral support, perseverance, and help when composing the training report.



DECLARATION

We hereby declare that, this thesis has been done by us under the supervision of **Dr. Md. Mahbubul Haque**, Professor & Program Director, M.Sc of **Department of Textile Engineering, Daffodil International University**.

We also hereby declare that neither this report nor any part of this report has been submitted elsewhere for award of any degree.

This is to certify that the above declaration made by the candidate is correct to the best of our knowledge.

Handwritten signature of Sabbir Hossain in black ink.

Handwritten signature of Debasish Sarker in black ink.

Handwritten signature of Tafsir Ahmed Toha in black ink.

Sabbir Hossain

Debasish Sarker

Tafsir Ahmed Toha

ID: 192-23-5676

ID: 192-23-5696

ID: 192-23-5667

**Department of Textile Engineering
Daffodil International University**



Table Of contents

APPROVAL SHEET	ii
ACKNOWLEDGEMENT	iii
DECLARATION	iv
Table Of contents	v
List Of Figures	vii
Chapter 1: Introduction	1
1.1: Introduction.....	1
1.2: Objectives of this project:	1
1.3: Information about the factory:	1
1.4: Weaving machine specification:	4
Chapter 2: Literature Review	5
2.1: Definition of loom	5
2.2: Objective of using loom.....	5
2.3: Process flowchart of loom	5
2.4: Description of different types of looms	6
2.4.1: Shuttle loom:.....	6
2.4.2: Shuttle less loom:.....	6
2.4.3: Projectile loom.....	6
2.4.4: Rapier loom.....	7
2.4.5: Water jet loom	7
2.4.6: Air jet looms	7
2.4.7: History of Development of Rapier Technology:.....	7
Chapter 3: Methodology	10
3.1: Preparing the single beam.....	10
3.1.1: Beam length	10
3.1.2: Fitting the single PBC beam	11
3.2: Reed width	13
3.2.1 Maximum and minimum reed width:.....	13
3.2.2: Reed Denting procedure for waste selvage and body in dent	15
3.2.3: Mounting the reed in reed holder.....	15
3.2.4: Procedure	17
3.2.5: Adjustment.....	17



3.2.6 Alignment adjustment procedure	18
3.2.7: Assembling of ultra-light gripper weft lifter and alignment	19
3.3: Rapiertape	20
3.3.1: Rapiertape insertion:	20
3.3.2: Stroke setting	21
3.3.3: Upper tape guiding sector settings	23
3.3.3: Bottom tape guiding sector settings:	23
3.4: Weft selector setting:.....	24
3.4.1: Weft selector fixing with roto cutter:	24
3.4.2: Roto cut settings.....	24
3.4.3: Adjusting the weft stop hook	25
3.5: Dobby scale and frame height.....	25
3.5.1: Regarding dobbie scale and frame height.....	25
3.5.2: Regarding back rest height and depth	28
3.5.3: Regarding shed crossing of dobbie	28
3.5.4: ISD crossing.....	28
3.6: Problems due to weft insertion problems:	28
3.6.1: Weft not gripped the console display shows:888 weft stop due to no gripping- error position 0	28
3.6.2: Cut threads tape guide hook, 42-45 mm from the beat up point.....	28
Probable cause (verify)	28
3.6.3: Wefts not exchanged lost in center. The console display shows; 918 stop due to not exchange – error position 300 degree	29
3.6.4: Rh rapiertape loss. The console display shows, 934 wefts stop due to rh rapiertape – error position 300 degree.....	29
3.6.5: Cut threads in exchange area, 45-55 mm from beat up point	29
3.6.6: Slack threads warp stripes with raised threads, often noticeable to touch	29
3.6.7: Taut threads.....	30
3.6.8: Warp stripes continuous and generally regular stripes along full length of fabric	30
3.6.9: shedding errors defects across full width of the fabric	30
3.6.10: Quilted seam (puckered warp)	30
Chapter 4: Discussion of results	31
Chapter 5: Conclusion.....	32
References	32



List Of Figures

Figure No	Figure Name	Page No
Figure 1	Layout of buildings	2
Figure 2	Layout of the weaving floor	3
Figure 3	Itama 9500-2Denims rapier loom	4
Figure 4	Beam width	10
Figure 5	Full beam	11
Figure 6	Side Buffer	11
Figure 7	Handle and contrast roller	12
Figure 8	Beam wheel	12
Figure 9	Beam anchor	13
Figure 10	Reed length	14
Figure 11	Standard reeding for Leno device binding (2-4 ends)	15
Figure 12	Reed holder	16
Figure 13	Spacing between reed and support bracket	16
Figure 14	Spacing between reed and support bracket	17
Figure 15	Reed adjustment point	17
Figure 16	Vertical Alignment	18
Figure 17	Horizontal adjustment	19
Figure 18	Gripper Template	19
Figure 19	Weft exchange point	20
Figure 20	Rapier tape setting	21
Figure 21	Rapier to teeth distance	21
Figure 22	Stroke setting	22
Figure 23	Left and right rapier	22
Figure 24	Upper tape guiding sector settings	23
Figure 25	Bottom tape guiding sector settings	23
Figure 26	Weft selector	24
Figure 27	Roto cut settings	25
Figure 28	Adjusting the weft stop hook	25
Figure 29	Dobby frame box	26
Figure 30	Dobby scale and frame height setting	27



Chapter 1: Introduction

1.1: Introduction

Rapier loom is a shuttle less weaving loom wherein the filling yarn is carried via the shed of warp yarns to the opposite side of the loom through finger like vendors called rapiers. Rapier weaving machines are acknowledged for his or her reliability and overall performance. A completely extensive range of fabric may be woven on a rapier weaving device that's commonly from very mild fabrics with 20 g/m² to heavy fabrics with round 850 g/m². Rapier machines are extensively used for household textiles and industrial fabric. Designed for usual use, the rapier weaving system can weave now not only the conventional wool, cotton and guy made fibers, however additionally the most technically stressful filament yarns, finest silk and fancy yarns. In this project (thesis) we worked on itema 9500 2nd generation rapier loom. We worked on various settings of this loom such as: preparing the single beam, mounting of the reed, alignment adjustment procedure, reed denting procedure and weft selector setting etc. During these commissioning some problems have generated and causes and remedies are also verified.

1.2: Objectives of this project:

1. To know about different setting procedures of this newly installed loom.
2. To know about the mounting process of reed.
3. To know about the alignment adjustment.
4. To know about the upper tape guiding settings.
5. To know about the bottom tape guiding settings.
6. To know about the reed denting process.
7. To know about the problems and causes due to weft insertion.

1.3: Information about the factory:

For our project we went to Universal Denims Limited. The company produces denim fabric. They have three sections: Dyeing, weaving & finishing. This is a rising industry with state of the arc facilities. Our thesis focuses of the weaving section. This weaving section has the latest modernized weaving looms. The loom we studied is IteMa R9500-2denims rapier loom. This is dual rapier loom, meaning it has two rapier one is gripper and other is receiver. Our project shows how the newly installed machine is set up for weaving. We will discuss the important parts of this setup process. The layout of the factory is show below in the figure:

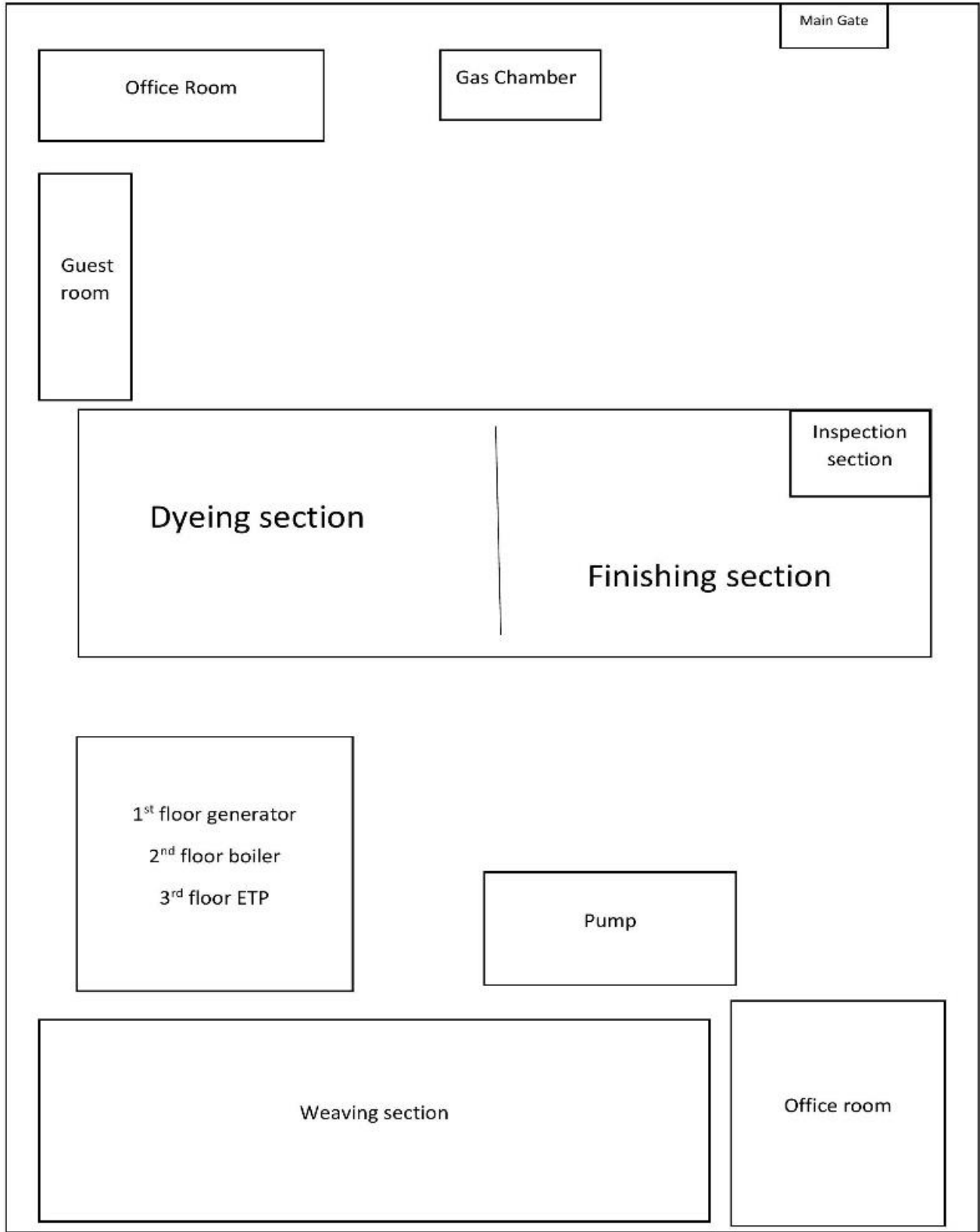

Figure 1: Layout of buildings

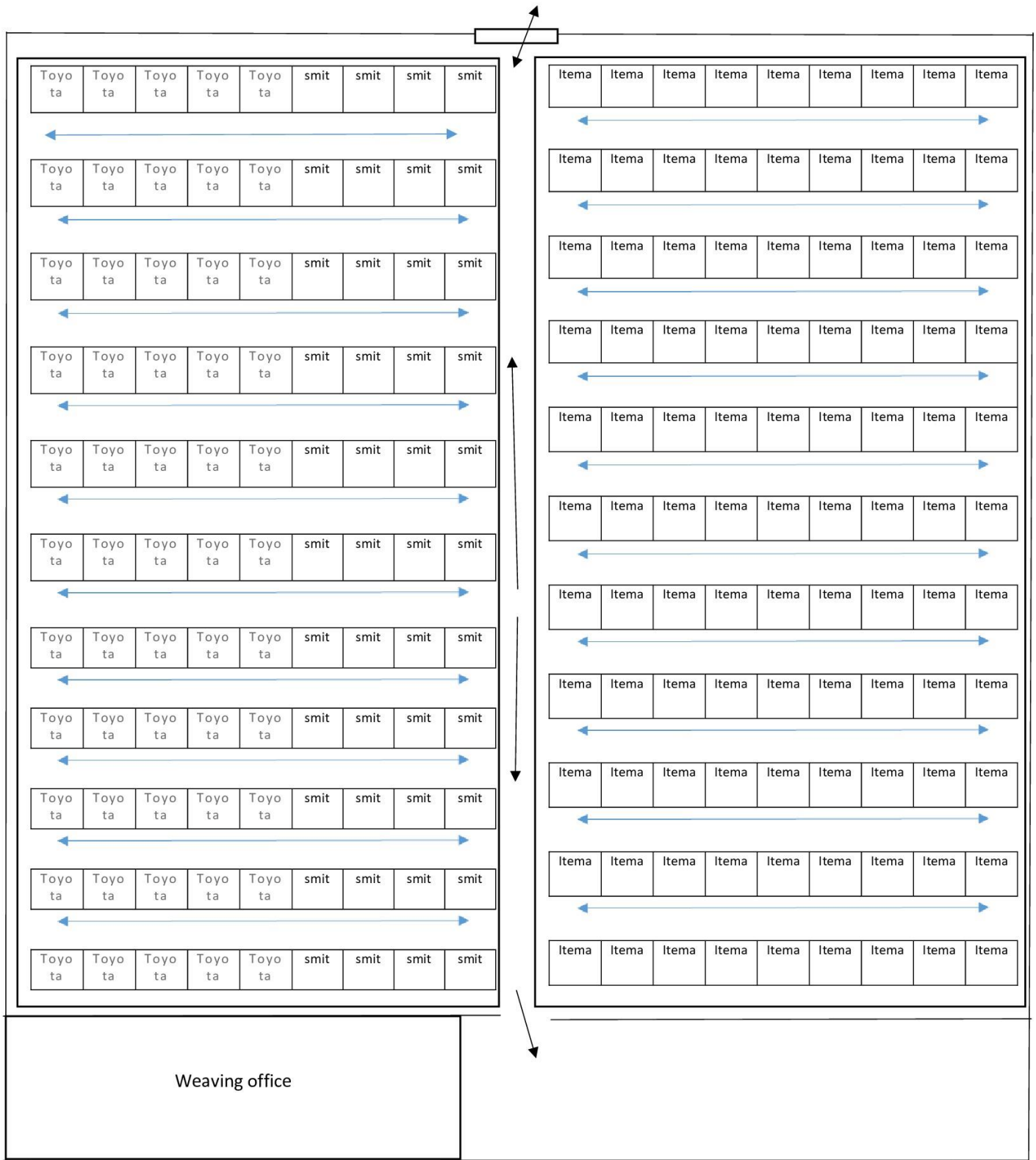

Figure 2: Layout of the weaving floor

1.4: Weaving machine specification:

Machine name	Itema S.P.A
Model No	R9500-2 Denims
Origin	Italy
Heald capacity	12
Year of manufacturing	2021
RPM	650
Maximum Reed length	220cm
Reed type	Plain
Shedding	Dobby
Maximum weft color	8
Let off motion	Electronic
Take up motion	Electronic
No of machines	99



Figure 3: Itema R9500-2denims rapier loom



Chapter 2: Literature Review

2.1: Definition of loom

A loom is a tool or machine that weaves cloth by weaving warp and weft yarn together. The steps taken before weaving include ginning, opening, cleaning, carding, combing, drawing, spinning, winding, warping, sizing, and beaming. All of these processes lead to a loom.

2.2: Objective of using loom

The tool used to weave cloth and tapestries is called a loom. Any loom's primary function is to maintain tension on the warp threads in order to make it easier for the weft threads to interlace.

The mechanics and exact shape of the loom can change, but its fundamental purpose always remains the same. Loom is propelled by two mechanisms. Both manual and automatic mechanisms are present here.

2.3: Process flowchart of loom

The process of preparing a loom before starting the **weaving process** is commonly known as looming. It includes drawing in draft (did), denting, pinning, gaiting, and knotting of warp threads by using different looming elements (drawing hook, denting plate).

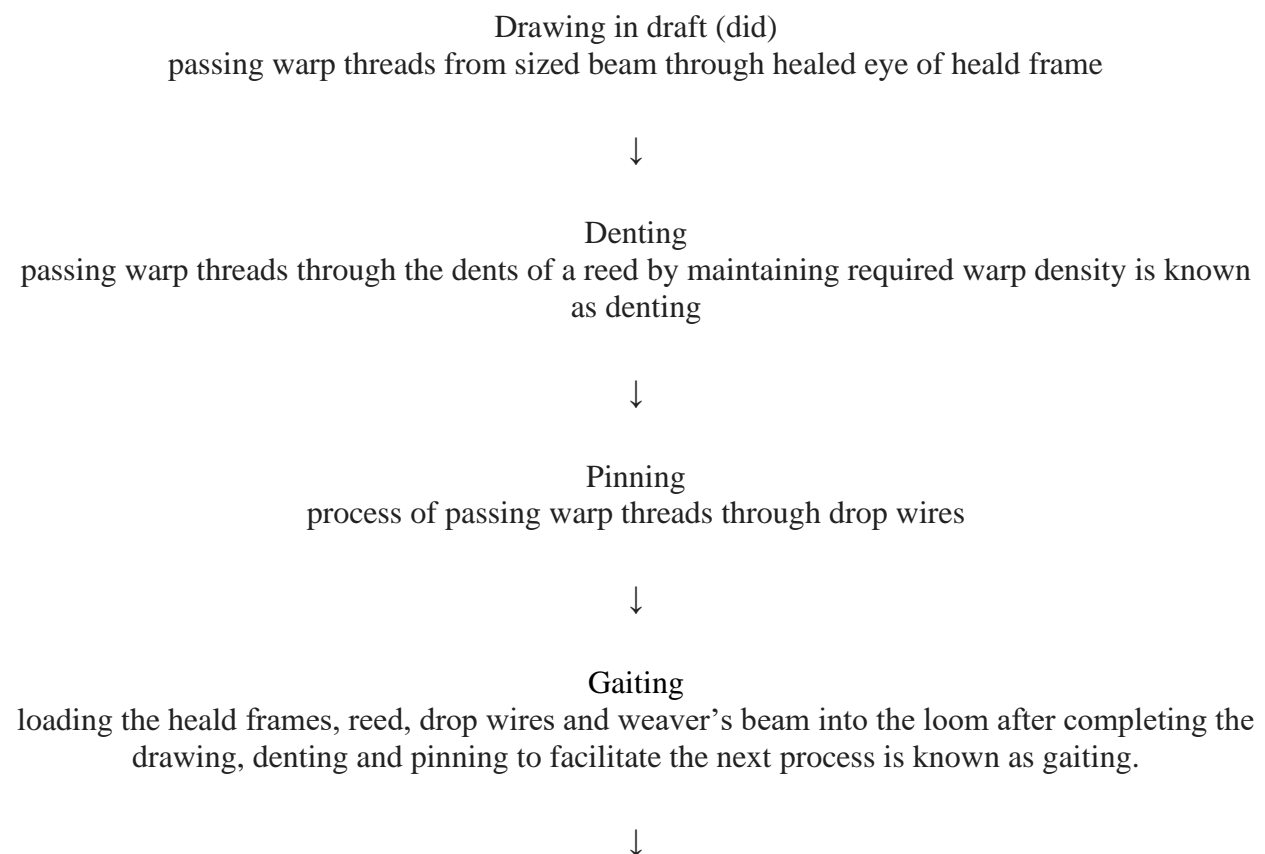



Tying-in/knotting

process of tying up the new warp yarns of a full beam with the corresponded old weaver's beam



Knotting types

1. Hand knotting
2. Automatic knotting

2.4: Description of different types of looms

2.4.1: Shuttle loom:

The shuttle loom, which utilizes a shuttle with a bobbin of filled yarn that emerges through a hole in the side, is the first type of weaving loom. The shuttle is moved across the loom while being hit, and

During the filling process, a trail of the filling is left behind at a rate of roughly 110 to 225 picks per minute (ppm). The shuttle looms are cumbersome and noisy, despite being extremely effective and adaptable. Additionally, the shuttle occasionally creates thread breaks and causes abrasion on the warp yarns. The machine must therefore be stopped in order to tie the broken yarns.

2.4.2: Shuttle less loom:

Many kinds of shuttleless looms are used for weaving such as projectile looms; rapier looms; water jet looms, and air jet looms.

2.4.3: Projectile loom

A weaving device that grips the weft thread with one or more jaws attached to a projectile before firing it through the shed. It contains a little hook-like feature that holds the filler yarn's end. It is frequently referred to as a missile loom since the picking operation is carried out by a number of tiny projectiles that resemble bullets and transport the weft yarn through the shed before returning empty.

The loom's same side is used to input each filler yarn. The weft ends are tucked into the selvage, which is the edge of the fabric, via a unique method. To reduce friction, this loom needs yarn that is uniformly smooth and of the right size. Projectile loom can produce up to 300 ppm and is less noisy than the shuttle loom.



2.4.4: Rapier loom

The mechanism for moving the weft through the shed in rapier looms is fixed at the end of a stiff rod or in a flexible ribbon, and it is positively propelled.

A rapier machine may have one rapier to transport the weft over the entire width, one rapier operating bilaterally with a bilateral weft supply positioned in the middle, or two rapiers operating on the opposing sides of the machine.

Rapier looms have a speed range of 200 to 260 ppm and are very effective. These looms are capable of producing a wide range of fabrics, including muslin cloth, curtain fabric, and even upholstery fabric.

2.4.5: Water jet loom

A water jet is accelerated across the shed in a water jet loom, carrying the filled yarn to the opposite side.

In it, a jet of water is used to move a predetermined length of weft yarn across the loom. With speeds up to 600 ppm and very little noise, these looms are extremely quick. They also apply little tension to the filler yarn.

2.4.6: Air jet looms

In an air jet loom, the weft yarn is propelled through the shed at up to 600 ppm by a jet of air that is projected across the shed with enough force to carry the filled yarn to the other side. On this loom, making fabrics requires the use of uniform weft yarns

2.4.7: History of Development of Rapier Technology:

Rapier looms vary substantially in both the overall strategies in their layout, consisting of the choice of technique used to switch the weft among the rapiers and the styles of rapier used- rigid, flexible or telescopic- and in info of mechanism used. Those machines find preferential use inside the production of with style-enchancement in comparison to different techniques of weft insertion that are particularly suitable for weaving staple items with constrained style-attraction. Ease of multicolor weft insertion is completely exploited via rapier looms - many can insert as much as 12 shades in any pick-at-will patterning collection, together with their potential to address a wide variety of yarns and cloth kinds. The nice rapier drives allows heavy or in any other case hard yarns to be inserted. The inflexible rapier gadget of weft insertion has the benefit of fine thread switch inside the centre of the shed without any want for steering the rigid rapiers through the shed



and without making contact with the warp thread. But that is at the cost of occupying more ground area, which reasons reed width of the rigid rapier to be restrained. The flexible rapier system of weft insertion has the recognition of being most adaptable and maximum relevant. The exquisite characteristic of bendy rapier gadget is its vast increase in weft insertion rate, extra reed width (460cm), versatility and flexibility. Within the last 15 years or so the layout of the rapier machine has been revolutionized by new improvements, engineering walkthroughs, automation in methods, creation of pc era, electronics and CAD-CAM systems. The weaving industry on the complete has entered a new technology of electronics, microprocessors, facts era and their application to the production of woven fabric. Incorporation of electronic devices and machine to weaving machines has turn out to be almost inseparable a part of the machine. Tendencies, especially of microprocessors, have revolutionized the layout of the rapier weaving machines, including the weft propulsion technology. The weft insertion elements had been made smaller and lighter in weight. Some terms associated with rapier loom are discussed bellow.

Picking Speed:

In jacquard weaving upto 12 weft colorations provide a extensive form of patterning alternative. The G6500 gives a device pace of upto seven-hundred rpm and a maximum weft insertion charge of 1620 m/min.

Secure Filling Transfer

At some stage in center switch from the left-hand to the right-hand rapier, the filling is undoubtedly managed and therefore securely transferred. The filling is released after the rapier has exited the shed in the open shed function and beneath clearly control situations. In Dornier rapier weaving device, the highest peak yarn tension is extraordinarily low because of the low rapier velocity and nice control. Tender thread clamps with difficult metallic inserts and precision-controlled transfer allow even coarse filament yarns of 2200 d tex with 450 filaments to be securely clamped and inserted

Versatility of Rapier Gripper

A brand-new era rapiers able to coping with even the maximum difficult of yarns, ordinary of the state-of-the-art developments in style fabric. The rapiers are light-weight and compact and hooked up at the centre of gravity on the ribbons to lessen wear to the minimal and assure most accuracy in motion. It enables the processing of the widest variety of yarn sorts and counts – from quality silk yarns thru glass ravings to the coarsest impact yarns. The depend range lies among 0. Seventy-seven tex and 3333 tex. The weft trade also takes area in sluggish speed, thus making life a long way less difficult for the ones worried in adjusting the system putting and at machine begin-up.



Light and Small Rapier Head

The new light-weight guided gripper model allows better speeds, and because the less complicated presentation into the gripper clamp requires less filling anxiety, the quantity of filling stops is decreased. The mild gripper is also smaller, which ends up in a smoother front of the gripper in the shed, ensures much less friction on the warp yarns. This reduces the warp breaks.

Versatile and Synchronized Weft Cutter

A superbly green weft cutter mechanism is needed for use of a extensive variety of yarn in rapier weaving gadget. Leonardo has the weft cutter having direct tools power, making sure constancy and precision and decreasing yarn wastage. The rapier head inserts any kind of weft. With the "RotoCut" in G6500, electronically controlled weft cutter, the timing of weft cutting is optimized. The "RotoCut" always cuts the weft on the nice viable second, regardless of yarn kind and material.

Electronic Filling Tension Controller

It controls the filling brake guarantees a present-day yarn tension at any time throughout insertion cycle. It could be installed for each channel among the pre-winder and access of constant major nozzle. It has been designed to sluggish down the filling at the stop of insertion. It for this reason substantially reduces the height anxiety of the select at the end of the insertion and decrease the tendency of pick to get better within the shed. Because of which the filling tip is stretched correctly with the subsequent capabilities;

- lower peak anxiety in filling yarn.
- reduced tendency of filling to get better.
- Inserted select can be stretched more effortlessly.
- modifications are accomplished by means of machine keyboard and display.
- The settings may be followed for each filling yarn
- Fewer filling breaks.
- Fewer system stops.
- better material quality.
- higher productiveness of gadget and staff.
- Weaker filling yarn can be used.
- correct putting of filling waste length and therefore much less waste



Pick Finding

On the filling breaks the gadget stops and only the harnesses are moved routinely to loose the damaged pick out for removal by the weaver. The necessities that select finding function is reached with not less than reed movements through the beat-up line. In GamMax, the select locating is surely executed through the Sumo motor at sluggish velocity

Chapter 3: Methodology

3.1: Preparing the single beam

The first thing that is prepared is the beams. The beams are taken out of the packaging and assembled. After assembly they are sent to the dyeing section where dyed and sized yarns are wound on the PVC beam for weaving.

3.1.1: Beam length

The Beam is taken out of packaging and assembled. The length of the beam is proportional to the reed length. The beam length is the same as the fabric width. And the reed is also the same width. Some extra width is added sometimes for the waste selvage.

symmetrical reduction in the reeded width, $A=A1=163\text{mm}$

B (Beam width) = C (reeded width)

Or: B (Beam width) = C (reeded width) + 20 mm

Note: - B must never be less than C .

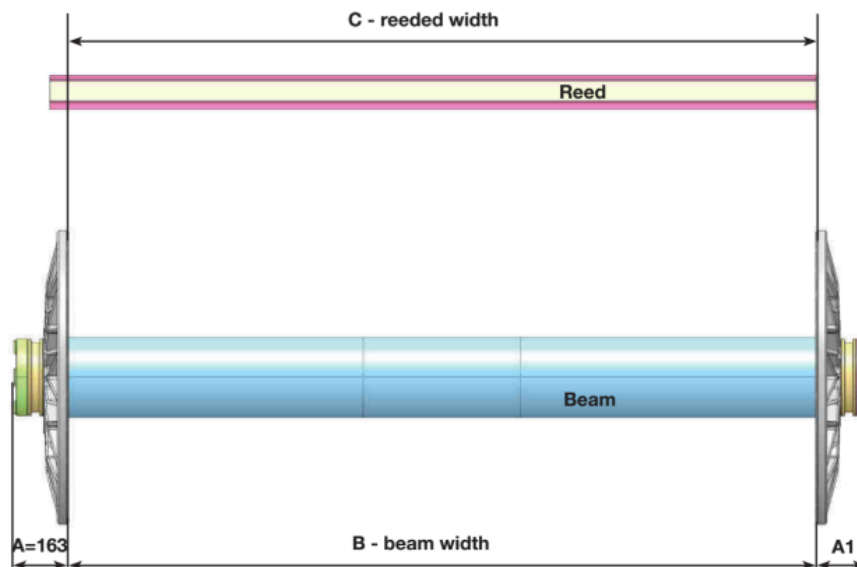

Figure 4: Beam width (Scanned from user manual)

For fixed LH side the flange should be 163mm at least from the beam adaptor. So that the reed can be fixed at the LH side. If symmetric beaming done then we want to position the reed Centre corresponding to loom Centre mark in the slay.



Figure 5: Full beam

3.1.2: Fitting the single PBC beam

The fitting procedure of the PVC beam are:

1. Mount the side buffers B and C on the cylinder of the beam A.

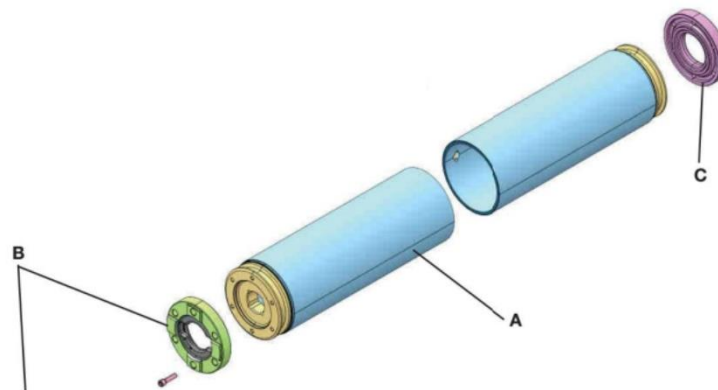

Figure 6: Side Buffer (Scanned from user manual)

2. Release the handle D and take the contrast roller E to its top position.

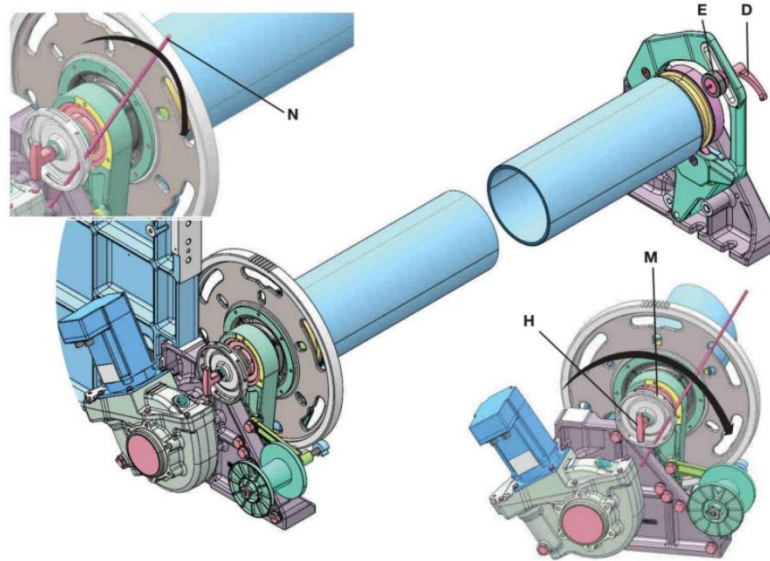

Figure 7: Handle and contrast roller (Scanned from user manual)

3. Lift the warp beam using the appropriate trolley and rest it on the supports on the loom.
4. Gently turn the beam so that the teeth of the small flange F on the toothed beam drive wheel slot into teeth of the small flange B on the beam itself.

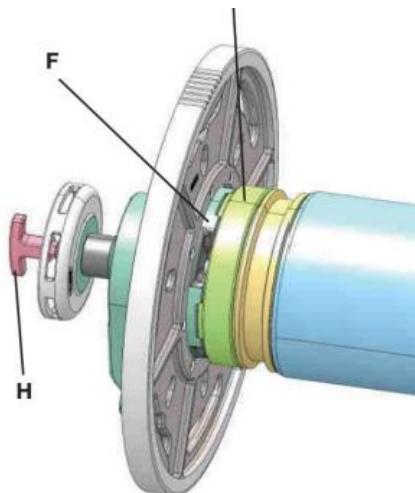

Figure 8: Beam wheel (Scanned from user manual)

5. Insert the anchor G in the small flange B by pushing the handle H inwards

6. Once the anchor is inserted, turn the handle H clockwise until the anchor is correctly positioned against the stop plate L, on the inside.

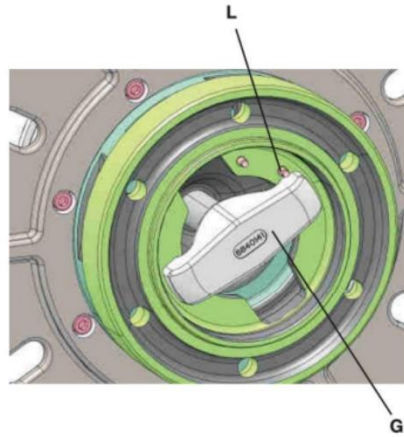

Figure 9: Beam anchor (Scanned from user manual)

3.2: Reed width

Determining the reed width is very important. After Securing reed in the reed slot, we might need to add extra brackets to fill the space so the rapier can travel smoothly. Without securing the reed in the reed slot the next procedures cannot be done.

3.2.1 Maximum and minimum reed width:

The maximum reed width supported by this machine is 2242mm. But the reed width used in every production cycle is determined by the width of the fabric. Usually, the fabric length is the reed length. But extra width is added for the wastage selvedge. The supported reed widths are shown below:

NOMINAL WIDTH	B	A1	A2		A2S
			Transfer SK		
2200mm	2250mm	2242mm	1642mm		1242mm

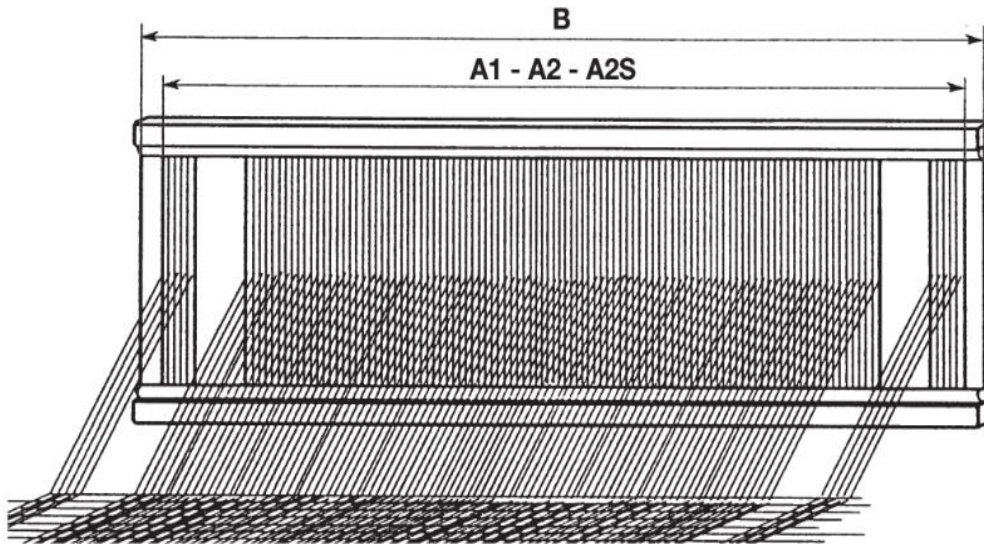

Figure 10: Reed length (Scanned from user manual)

The minimum and maximum wearable width of 2200 mm loom

A1- Maximum reed width

Maximum width of the thread is selvages, gaps and false selvages passing through the reed.

A2 - Minimum reed width with standard guides

Minimum width of the thread is selvages, gaps and false selvages passing through the reed (including).

A2- Minimum reed width with special guides not included in the standard equipment

Minimum width of the thread is selvages, gaps and false selvages passing through the reed. We are following these weaving limitations when the loom is set up in this manner.

B-Reed space

Maximum space on the machine for positioning and fixing the reed.

3.2.2: Reed Denting procedure for waste selvage and body in dent

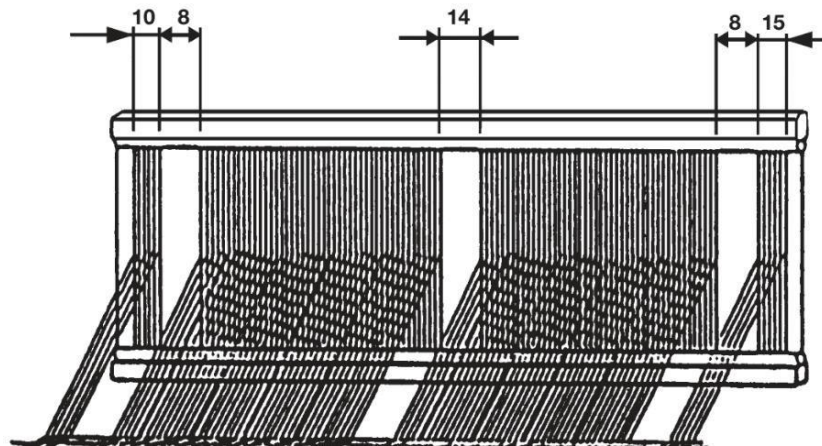

Figure 11: Standard reeding for Leno device binding (2-4 ends) (Scanned from user manual)

Left false selvage first	=10 mm
Clearance for LH leno device	=8 mm
Clearance for central leno device	=14 mm
Clearance for RH leno device	= 8 mm
Right false selvage last	=15 mm

Distance between fabric front rest and reed after fixing reed in tight condition should be 1.5 mm to 2 mm at 0 degree

3.2.3: Mounting the reed in reed holder

1. Manually take the loom to 0°.
2. Mount the reed A in its seat.
3. Position the reed A, bearing in mind that the Centre of the fabric must be in line with the Centre of the race by checking that the distance from the first warp end to the beginning of the race is the same on both side.
4. The reed A is shorter than the race B, some shimming spacer's C need to be mounted at either end of the race.
5. Close the reed locking wedge D by tightening the nuts E at 5 Nm starting in the Centre of the machine and working towards the sides

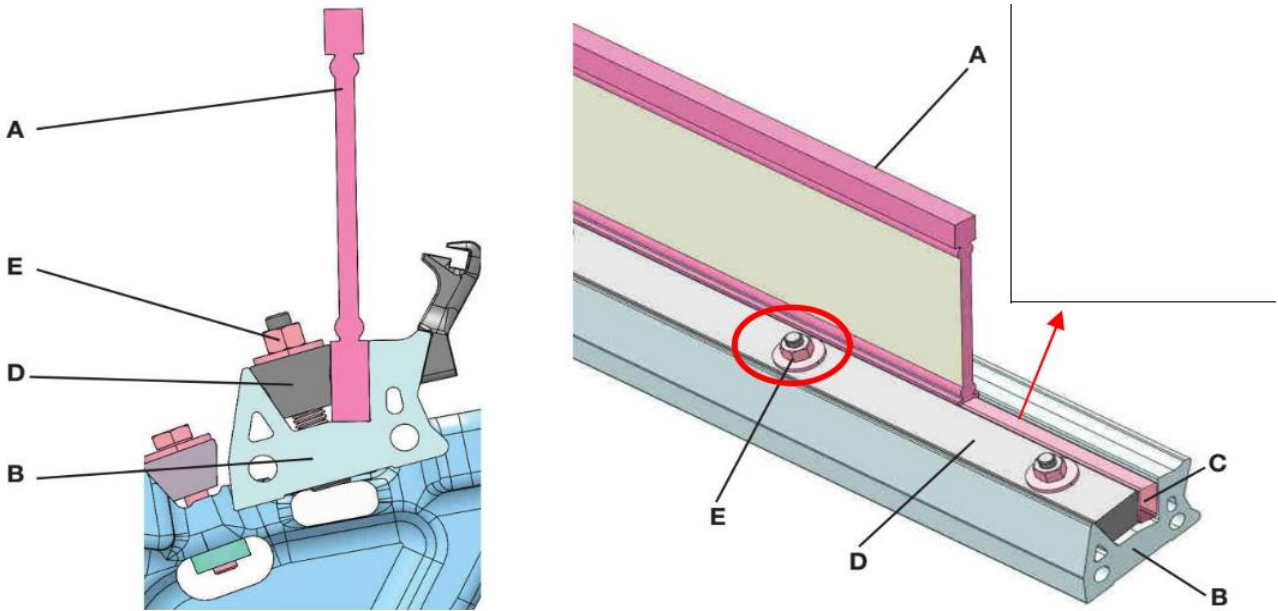

Figure 12: Reed holder (Scanned from user manual)

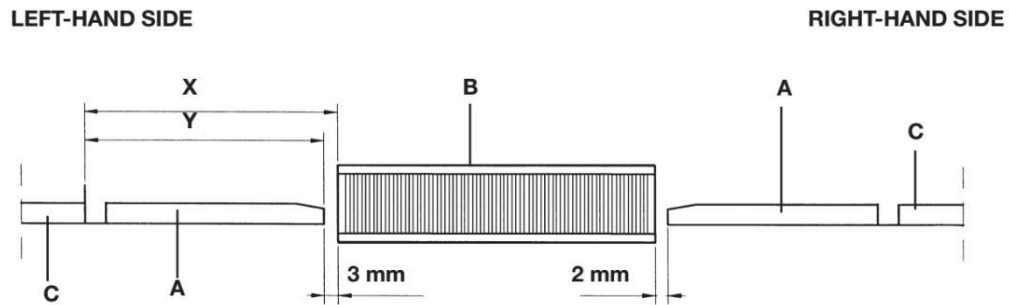

Figure 13: Spacing between reed and support bracket

Lateral guide should be fixed within the specified gap in between each other the last guide near to drive wheel can be positioned 50 mm away maximum and gap between 02 lateral guide bits should be maximum 25 mm.

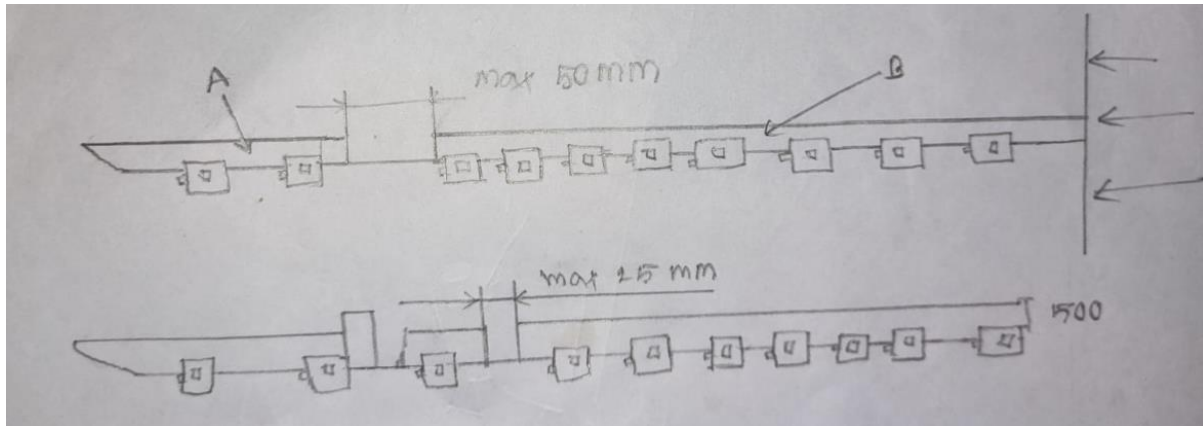

Figure 14: Spacing between reed and support bracket

3.2.4: Procedure

1. manually take the loom to 0° (reed in beat-up position);
2. insert the alignment template D1 in the guide B in such a way that it does not stick out from either beam.
3. take the machine to 180° with the race C lined up against the tape guide B.
4. Push the template D1 towards the race C and make sure it engages without interfering with the first tape guiding hooks G, then run it along the race to check that all the other hooks along the race and the guides on the opposite side of the machine are correctly aligned.

3.2.5: Adjustment

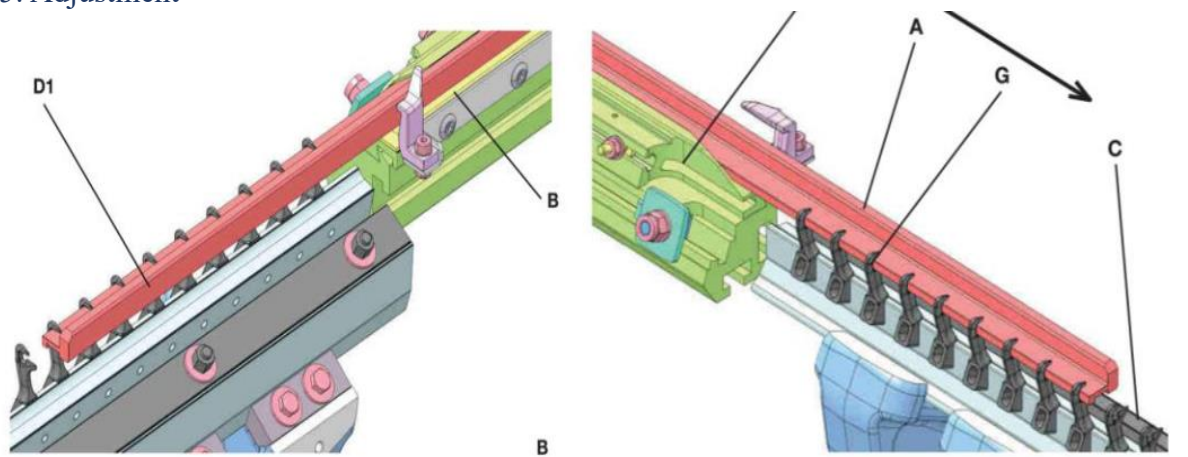

Figure 15: Reed adjustment point (Scanned from user manual)

1. If the template does not slide smoothly inside the race, the procedure described below should be followed.

2. Identify the tape guiding hooks G which prevent the template D1 from sliding and check whether they have been mounted correctly with regard to the bearing surface on the race P.
3. Loosen the screws V, reposition the hooks correctly and then, while pressing the hooks down lightly on the bearing surface on the race, tighten 3Nm the screws V again using a torque wrench at 3 Nm.
4. Test again whether the alignment template D1 slides smoothly along the race C.

If there are still problems in smooth sliding, the tape guiding hooks G involved must be replaced.

If one of the first three tape guiding hooks stops the template from running smoothly, adopt the necessary action to suit the case as described below

3.2.6 Alignment adjustment procedure

Vertical Alignment

1. Slightly loosen the screw M of the clamp N and turn the screw L in the required direction until the template is free to slide among the tape guiding hooks.
2. Tighten the screw M again and check that the template runs smoothly.

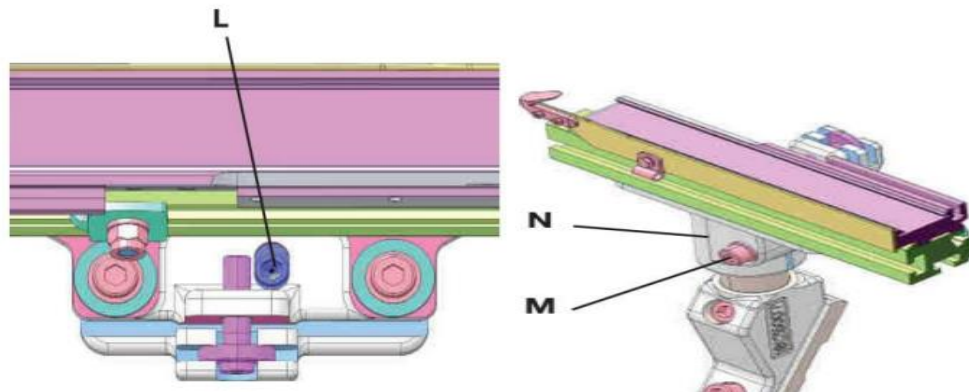

Figure 16: Vertical Alignment (Scanned from user manual)

Horizontal adjustment

1. Slightly loosen the two screws P while making sure that the respective Belleville washers Q are kept under tension.
2. Turn the screw R in the required direction until the template can slide among the hooks.
3. Tighten the screw P again and check that the template runs smoothly.

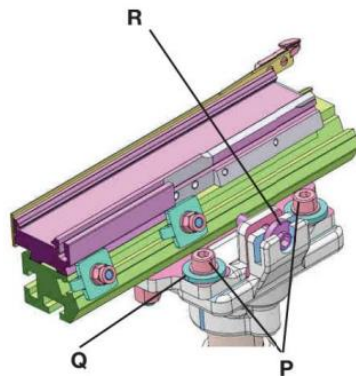

Figure 17: Horizontal adjustment (Scanned from user manual)

3.2.7: Assembling of ultra-light gripper weft lifter and alignment

1. If using an SK ultra-light transfer, you will need to fit a weft lifter plate (L) in addition to the adjustments described above for the SK transfer. To do this:

-Place the shim S on the guide G and secure using the screws V.

2. -Place the metal plate L on top of the shim S.
3. -Using the shim S1, secure the metal plate and its corresponding screws V1, but without tightening these completely in order to allow for fine adjustments to the position of the metal plate.
4. -With the machine at 0°, place the template D1
5. -Place the template D2 up against the template D1
6. -Now move the weft lifter (metal plate L) up against the template D2.
7. -Move the metal plate L as required so that the screws V1 are in the Centre of the slots and then tighten these screws V1
8. Slide the template D2 to make sure that the weft lifter stays parallel to the template D2.

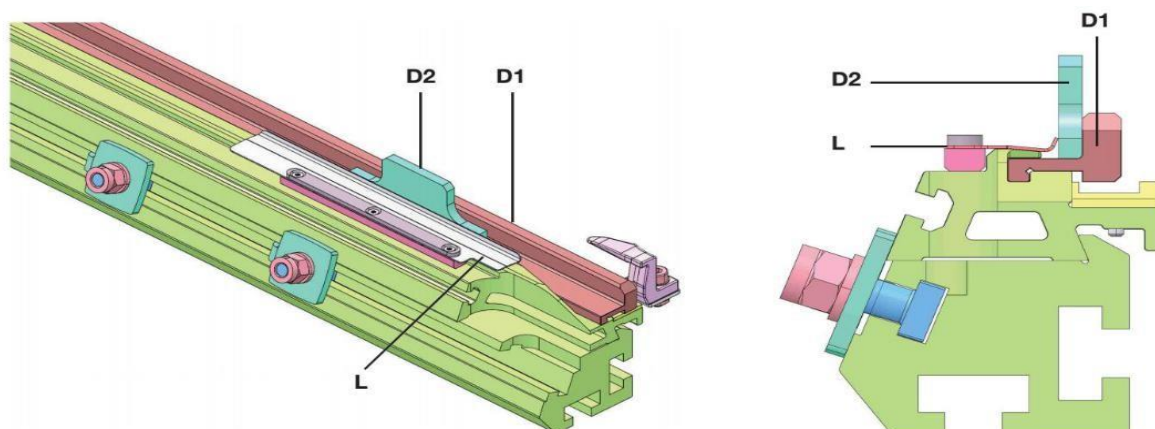

Figure 18: Gripper Template (Scanned from user manual)



3.3: Rapier tape

3.3.1: Rapier tape insertion:

After finishing the reed alignment, we insert the rapier tape. After inserting the rapier tape, we have to move the loom to 180° to keep the rapier setting. The loom should be moved only by hand and after releasing the parking brake.



Figure 19: Weft exchange point

The 180° setting is kept with reference to the Centre mark given in the reed holder.

- Engage the brake;
- Take the tip of the Left-Hand rapier 30 mm past the center of the race.
- Position the Right-Hand rapier as shown in Table 2 and then secure the tape drive wheel.

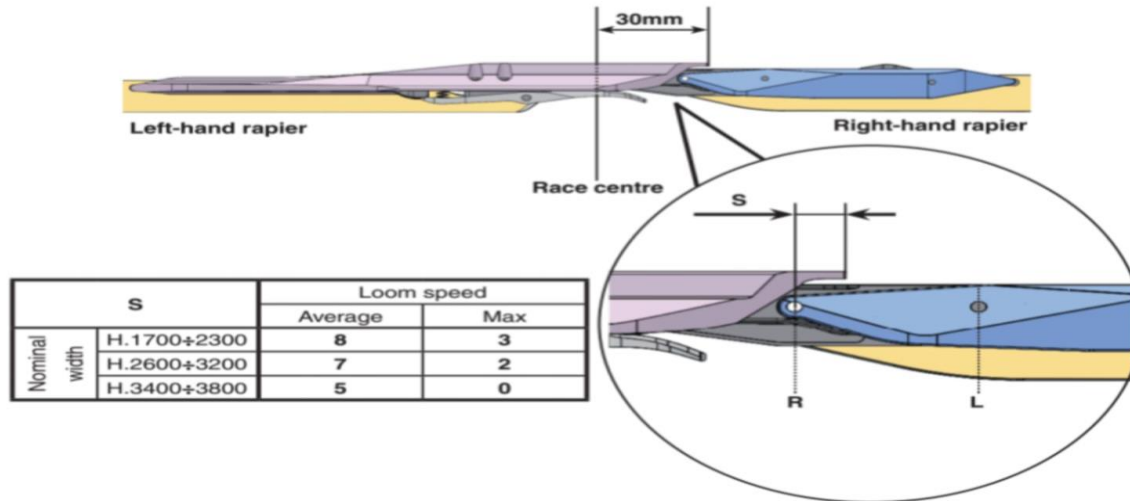

Figure 20: Rapier tape setting. (Scanned from user manual)

3.3.2: Stroke setting

To bring the required stroke, it could be running with long/short stroke before. If long stroke the gripper should be moved back towards the lateral guide and short stroke the gripper should be moved towards the reed. The calculation is same but it depends to move forward or backward depends on requirement.

After measuring the distance @ 290* the stroke could be adjusted only at 0*. Move the loom to 0 and release the brake. Then as per the measurement calculation according to the correction constant we have to do the stroke setting.

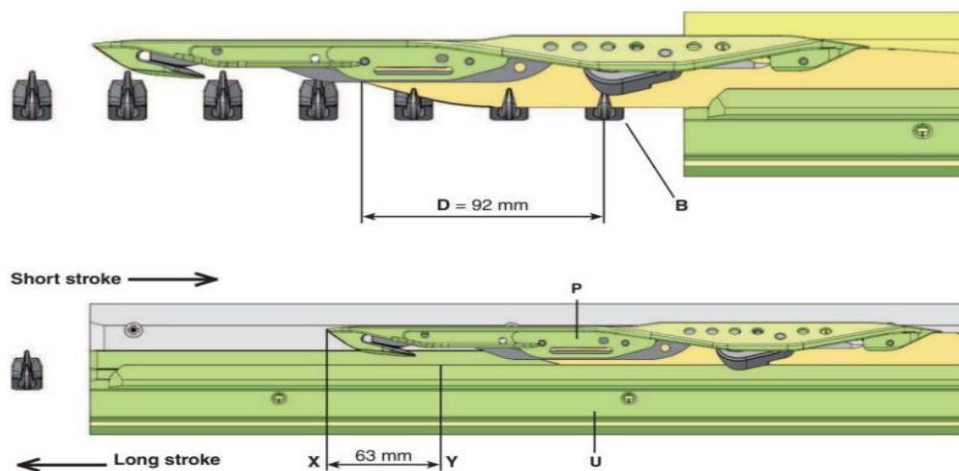

Figure 21: Rapier to teeth distance (Scanned from user manual)



Co-efficient value for H2200mm is 55 (K)

Calculate the distance of displacement XY as follows:

Use this formula to vary the stroke (off-ropier):

$$XY = \frac{D \times K}{100}$$

D=distance

K=co efficient value (55)

XY= 92*55/100 = 50.6 mm backward as per long stroke in picture.

XY= 63 55/100= 34.65 mm forward as per short stroke calculation.

If loom stroke has gone below 200 mm, then we have to change the stroke bolt position no 01 to position 04 as shown in picture and all the 03 bolts should be tightened @80 Nm

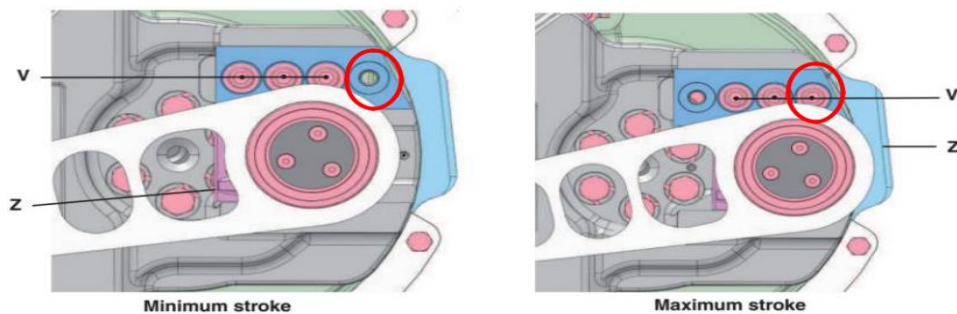

Figure 22: Stroke setting (Scanned from user manual)

After stroke completion the drive wheel bolts should be opened and we have to keep the 180 setting again. Later check the stroke at 290*

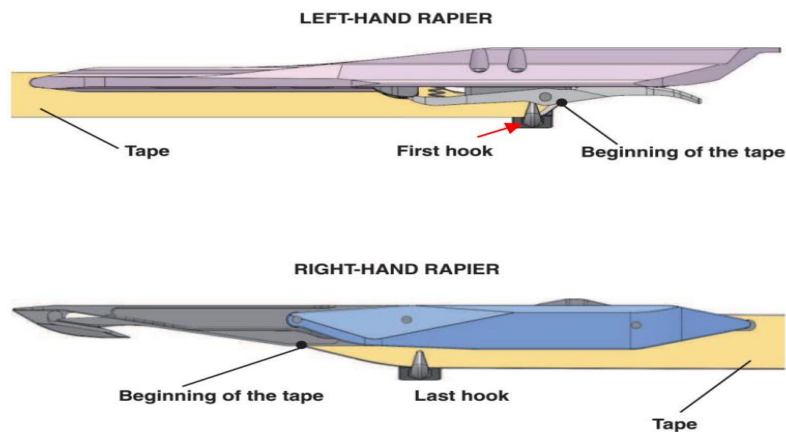

Figure 23: Left and right rapier (Scanned from user manual)

The LHS gripper can be kept maximum of 60 mm inside the reed and RHS gripper can be kept 120 mm maximum inside the reed @290*

If the stroke is completed then move the loom to 0* and LHS opener settings to be completed. Note-the opener should not press the lever too much, only the required amount to open the lever to clean according to weft quality.

3.3.3: Upper tape guiding sector settings

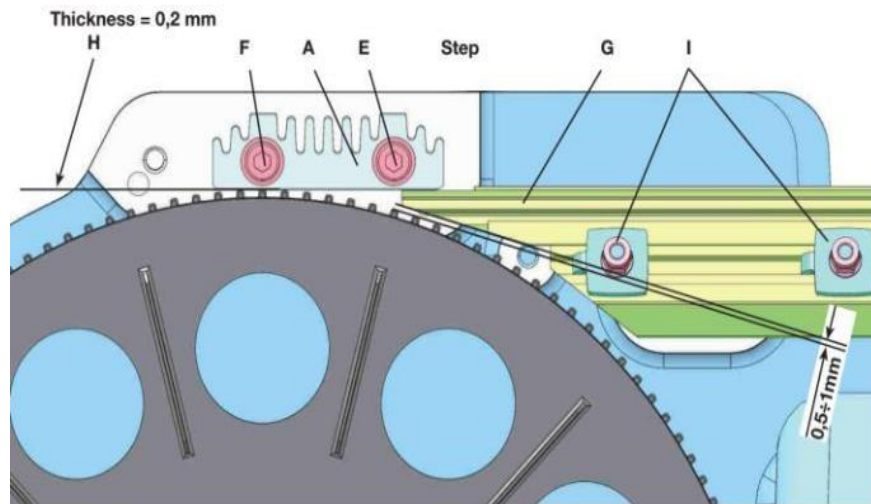

Figure 24: Upper tape guiding sector settings (Scanned from user manual)

3.3.3: Bottom tape guiding sector settings:

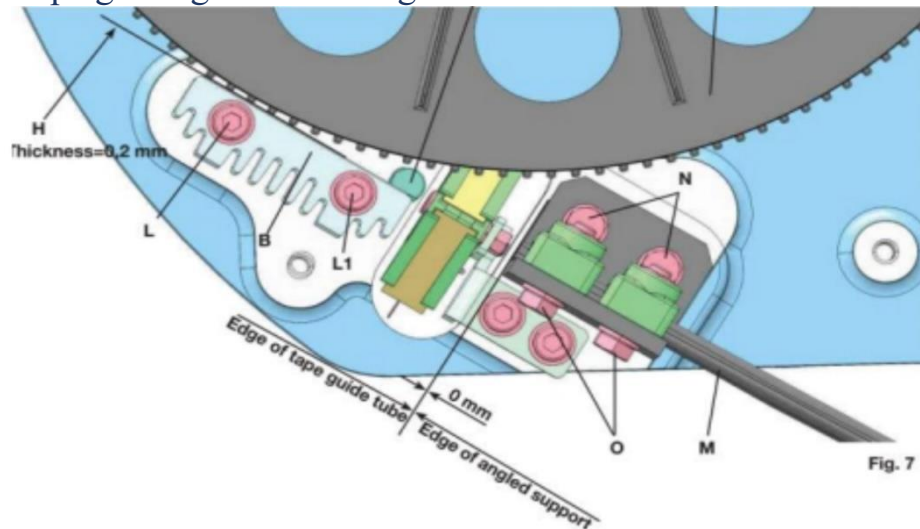

Figure 25: Bottom tape guiding sector settings (Scanned from user manual)

3.4: Weft selector setting:

3.4.1: Weft selector fixing with roto cutter:

Procedures are as follows;

1. Move the right-hand side of the weft color selector A until it is 120 mm from the reed B
2. To adjust the distance, loosen the screw G and move the weft colour selector unit D sideways.
3. Tighten the screw C.

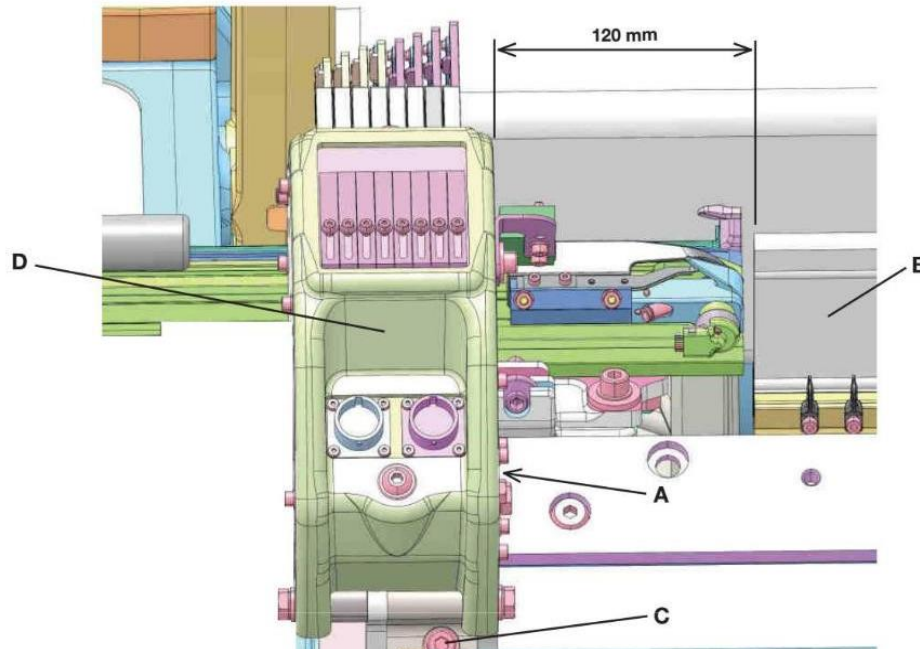

Figure 26: Weft selector (Scanned from user manual)

3.4.2: Roto cut settings

loosen the screws A and move the Rotocut unit sideways until it is parallel with the tape guide. Tighten the nuts A. Position the guide with the Rotocut weft cutter 3 mm from the reed by using the nuts C.

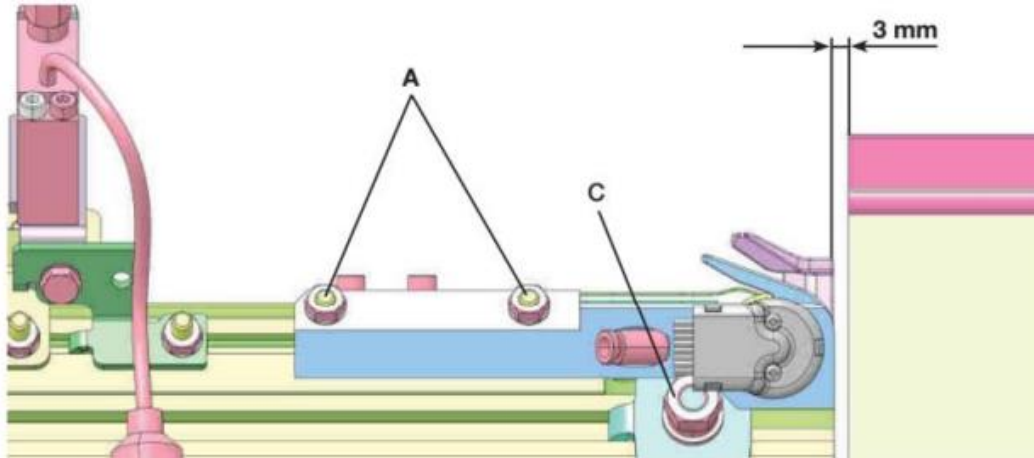

Figure 27: Roto cut settings (Scanned from user manual)

3.4.3: Adjusting the weft stop hook

The weft stop hook A is fixed in the reinforced temple support should be fitted in the following procedure. The hook should be lowered to hold the weft during beat up, not too much deep and it should be 1-2 mm from the reed on side wise.

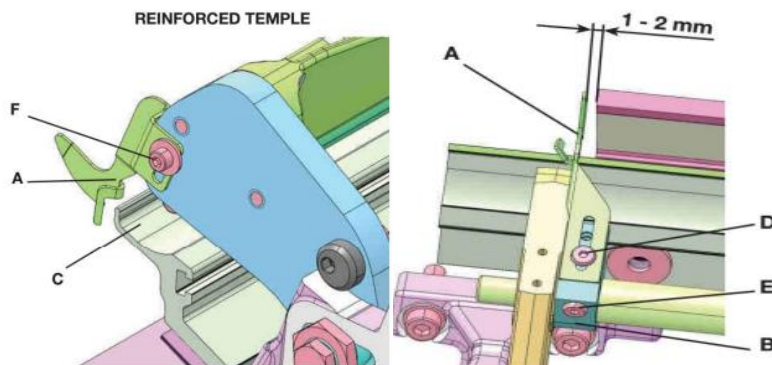

Figure 28: Adjusting the weft stop hook (Scanned from user manual)

3.5: Dobby scale and frame height

3.5.1: Regarding dobbie scale and frame height

For warp count range upto 12Ne and more warp ends it could be better to use 23* and count range more than 12 Ne can be run with 22* opening scale and the frame heights can be decided from 126 mm to 133 mm depending on requirement and weave and shed position over rapier (1 mm high from rapier body) and 1 mm low from guide hook tape transportation area minimum.

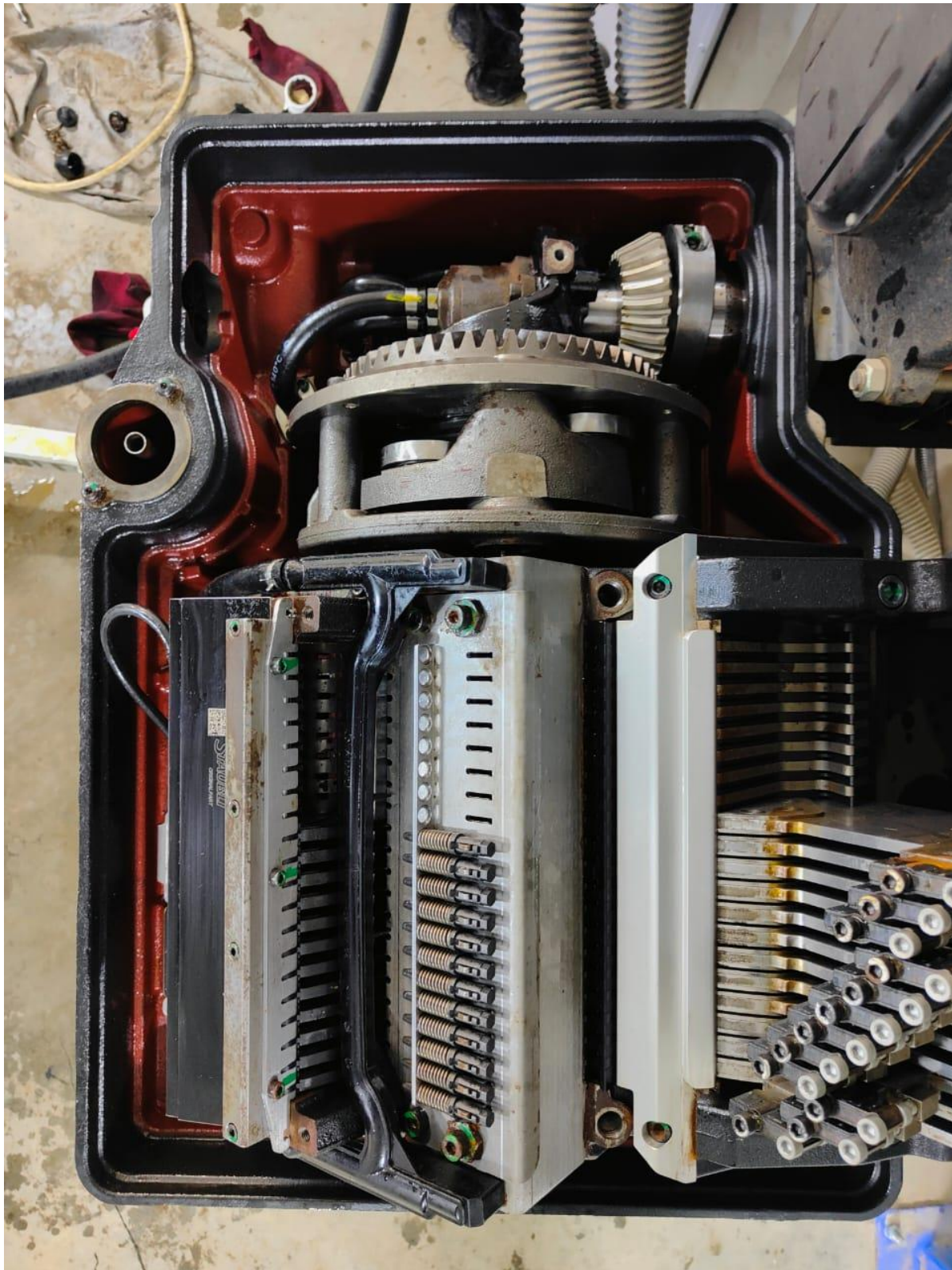

Figure 29: Dobby frame box



23-degree opening scale(A1) is the height to be fixed in dobbie jack lever. 22-degree opening scale (A1) is the height to be fixed in dobbie jack lever. Selection of clamp should be ERG (Ergonomic type) and heald wire eye should be 6.5 and dobbie model should be S3020



Figure 30: Dobby scale and frame height setting



3.5.2: Regarding back rest height and depth

The back rest should be kept in -3 (vertical) and 90 (horizontal) for symmetric shedding. In case of article with more bumping the back rest can be moved upwards to reduce bumping, but be cautious for starting mark

3.5.3: Regarding shed crossing of dobbie

The dobbie shed crossing can be between 300 to 320*. In order to keep less wastage, we can keep the shed crossing near to 300 degrees also consider the weave.

3.5.4: ISD crossing

Mostly the LHS ISD can be kept closer to loom shed crossing and the RHS ISD should be crossed in between 280 to 300 depending on the type of weft yarn we use.

3.6: Problems due to weft insertion problems:

Problems arises for different reasons. Itama 9500-2denims is a very modernized rapier loom. It has a lot of sensors all across the machine. The sensors detect every problem and shows them on the display. The system also has a built-in trouble shooting function. If trouble shooting doesn't work then it shows the probable fixes to those problems. And following those instruction solves the problems. Some of those problems are discussed below with their cause and solutions.

3.6.1: Weft not gripped the console display shows:888 weft stop due to no gripping- error position 0

Probable cause (verify)

- 1.1) warp shed geometry
- 1.2) integrity of tapes and rapiers (check there are no sharp edges or comers)
- 1.3) positioning and adjusting temple take-up
- 1.4) tension of warp threads
- 1.5) shed closing timing

3.6.2: Cut threads tape guide hook, 42-45 mm from the beat up point

Probable cause (verify)

- 2.1) raise the heald frames and/or increase the warp shed
- 2.2) stagger the heald frames near tape guide hook, 42-45 mm from beat-up point 3) Cut threads
- 2.3) smooth and/or round off the front corner of tape



2.4) smooth and/or round off the tape

3.6.3: Wefts not exchanged lost in center. The console display shows; 918 stop due to not exchange – error position 300 degree

Probable cause (verify)

- 3.1) insufficient weft braking exchanged or lost in center
- 3.2) position of rapiers at exchange
- 3.3) efficiency, cleanliness and integrity of rapiers
- 3.4) wear of tapes The Console display shows: 918 stop due to no exchange - error position 183°
- 3.5) uneven weft unwinding and braking
- 3.6) play between slides and worm screw
- 3.7) raise or lower heald frames completely

3.6.4: Rh rapier loss. The console display shows, 934 wefts stop due to rh rapier – error position 300 degree

Probable cause (verify)

- 4.1) lubricate weft if it tends to cut the warp threads
- 4.2) raise the heald frames 55-65 mm from beat-up point
- 4.3) lower the weft tension
- 4.4) state and wear of rapiers and tapes

3.6.5: Cut threads in exchange area, 45-55 mm from beat up point

Probable cause (verify)

- 5.1) raise the heald frames
- 5.2) increase the shed in exchange area, 45-55 mm from beat-up point
- 5.3) replace one or both rapiers
- 5.4) move the exchange point by 5/6 mm

3.6.6: Slack threads warp stripes with raised threads, often noticeable to touch

Probable cause (verify)

- 6.1) amplitude and symmetry of the shed and alignment of heald frames
- 6.2) type of drawing-in and type of reeding raised threads, often noticeable to the touch
- 6.3) imperfect beam with slack and/or interrupted yarn
- 6.4) timing of shed closing and of false selvedge



- 6.5) threading of selvedge and/or false selvedge
- 6.6) stability of leno device binding
- 6.7) positioning and adjustment of warp stop motion

3.6.7: Taut threads

Probable cause (verify)

- 7.1) imperfect beam with slack and/or taut yarn
- 7.2) excessive warp tension
- 7.3) amplitude and symmetry of the shed and alignment of heald frames
- 7.4) positioning and adjustment of warp stop motion

3.6.8: Warp stripes continuous and generally regular stripes along full length of fabric

Probable cause (verify)

- 8.1) reeding
- 8.2) defective reed dents Continuous and generally regular stripes along full length of fabric
- 8.3) levelling of backrest rollers
- 8.4) alignment of heald frames (if near the tape-guide hooks, check levelling of machine)
- 8.5) adjustment, efficiency, cleanliness and take-up of temples
- 8.6) adjustment of fabric rest (too low)

3.6.9: shedding errors defects across full width of the fabric

Probable cause (verify)

- 9.1) incorrect pattern programming
- 9.2) errors in pattern transfer (faulty USB or flash memory)
- 9.3) dobby malfunction defects across full width of fabric
- 9.4) amplitude and symmetry of the shed and alignment of heald frames

3.6.10: Quilted seam (puckered warp)

Probable cause (verify)

- 10.1) check for slack threads
- 10.2) advance/delay the closing of the shed



- 10.3) increase the warp shed
- 10.4) increase the warp tension
- 10.5) raise or lower the heald frames

Chapter 4: Discussion of results

1. The preparation of single beam:
 - i. This is the first thing need to focus for commissioning process.
 - ii. The flange should be 163 mm at least from the beam adaptor for fixed LH side.
 - iii. For symmetric beaming, need to position of the reed center corresponding to loom center mark in the slay.

2. The maximum reed width:
 - I. The max reed width of this machine is 2242 mm.
 - II. The reed width is determined by the width of the fabric in every production cycle.
 - III. The maximum width of the thread is selvages, gaps, and false selvages passing through the reed which is $A1=2242\text{mm}$. $A2= 1642\text{mm}$ for minimum reed width with standard guides. $A2S= 1242\text{mm}$ for min width but not included in the standard equipment.

3. Reed denting procedure:
 - I. It is an important thing for commissioning process which has impact on on waste selvedge.
 - II. So, leno device needs to be positioned at perfect distance (mm).
 - III. The distance between fabric front rest and reed should be 1.5 mm to 2 mm at 0 degree.
 - IV. But before it reed should be in tight condition.

4. Rapier tape insertion:
 - I. The rapier tape needs to insert after finishing reed alignment.
 - II. When rapier tape inserted into the loom, the loom needs to be moved 180*.
 - III. The LH rapier should be 30mm ahead from the center of the race.

5. Stroke Setting:
 - I. For stroke setting, the loom should move to 0 and release the brake.
 - II. After that as per the measurement calculation according to the correction constant stroke setting should be done.



6. Back rest height and depth:
 - I. In symmetric shedding; the back rest should be kept (-3) for vertical and (90) for horizontal.
 - II. Need to careful about the starting mark, when backrest move upward for reducing bumping.

Chapter 5: Conclusion

Weaving is a very important sector in Textile Industry. Different types of weaving looms play different significant roles in weaving. We are very lucky to work in the commissioning process of itema 9500 2nd generation rapier loom. By doing this project (thesis) report, We are able to learn about the commissioning process of itema 9500 2nd generation rapier loom such as, preparing the single beam, mounting of the reed , alignment adjustment procedure, reed denting procedure and weft selector setting etc. During these commissioning some problems have generated and causes and remedies are also verified. Overall, it was a great experience.

References

1. Maity, S., Singha, K., & Singha, M. (2012). Recent developments in rapier weaving machines in textiles. *American Journal of Systems Science*, 1(1), 7-16.
2. Model development; Textile Magazine; Issue4; 2008; pp36-39
3. Sound weaving, Feature article; The American Society of Mechanical Engineers; March; 2008
4. Ttimer S. T. and Dawson R. M., Filling insertion by rapier: a kinematic model. *Text. Res. Jnl* 58, 726-734 (1988).
5. <https://textilestudycenter.com/>
6. <https://www.textileblog.com/>
7. <https://textilelearner.net/>



Commissioning of newly installed weaving loom

ORIGINALITY REPORT

22%

SIMILARITY INDEX

19%

INTERNET SOURCES

2%

PUBLICATIONS

8%

STUDENT PAPERS

PRIMARY SOURCES

1

article.sapub.org

Internet Source

11%

2

www.textileschool.com

Internet Source

3%

3

Submitted to Daffodil International University

Student Paper

2%

4

Submitted to MAHSA University

Student Paper

1%

5

dspace.daffodilvarsity.edu.bd:8080

Internet Source

1%

6

www.sapub.org

Internet Source

1%

7

www.researchgate.net

Internet Source

1%

8

Submitted to Texas A&M University, College Station

Student Paper

1%

9

asrjetsjournal.org

Internet Source

<1%



10	Submitted to PSG Institute of Management Coimbatore Student Paper	<1 %
11	Submitted to RMIT University Student Paper	<1 %
12	Submitted to Higher Education Commission Pakistan Student Paper	<1 %
13	Submitted to University of Nottingham Student Paper	<1 %
14	pdfcoffee.com Internet Source	<1 %
15	textileapex.blogspot.com Internet Source	<1 %
16	patents.google.com Internet Source	<1 %
17	repository.ihu.edu.gr Internet Source	<1 %
18	"Cotton Science and Processing Technology", Springer Science and Business Media LLC, 2020 Publication	<1 %

Exclude quotes

Off

Exclude matches

Off