



Daffodil
International
University

**Explainable Deep Hybrid Network Approach for Multiclass
Classification of Dermatological Disorders from Macroscopic
Images**

Submitted By:

Nishat Anjum Purna

ID: 221-35-827

Department of Software Engineering

DAFFODIL INTERNATIONAL UNIVERSITY

Supervised By:

Fatama Bintu Rafiq

Lecturer (Senior Scale)

Department of Software Engineering

DAFFODIL INTERNATIONAL UNIVERSITY



Department of Software Engineering Faculty of Science and Information Technology
Supervisor Approval Form

Fall 2025	B.Sc. In SWE	Campus: DSC
-----------	--------------	-------------

Student Name	Student ID
Nishat Anjum Purna	221-35-827

Thesis Information	
Thesis Title	Explainable Deep Hybrid Network Approach for Multiclass Classification of Dermatological Disorders from Macroscopic Images
Type of work	Deep Learning, Machine Learning, XAI

Supervisor information	
Supervisor Name	Fatama Binta Rafiq
Supervisor Initial	FBR
Completed Credit till now	139
How many credits in this semester	6
Amount (Due)	0
Supervisor Consent	<input checked="" type="checkbox"/> Yes <input type="checkbox"/> No

Supervisor Signature

Fatama
28.11.25

DECLARATION OF THESIS AND COPYRIGHT

Author's Full Name : Nishat Anjum Purna

Date of Birth : 07 November,2001

Title : Explainable Deep Hybrid Network Approach for Multiclass
Classification of Dermatological Disorders from Macroscopic Images

Session : 2022-2025

I declare that this thesis is classified as:

- CONFIDENTIAL (Contains confidential information under the Official Secret Act 1997)*
- RESTRICTED (Contains restricted information as specified by the organization where research was done)*
- OPEN ACCESS I agree that my thesis to be published as online open access (Full Text)

I acknowledge that Daffodil International University reserves the following rights:

1. The Thesis is the Property of Daffodil International University.
2. The Library of Daffodil International University has the right to make copies of the thesis for the purpose of research only.
3. The Library of Daffodil International University has the right to make copies of the thesis for academic exchange.

Certified by:

Nishat Anjum Purna

(Student's Signature)

221-35-827

Student ID

Date:26-11-2025

Fatama Binta Rafiq
26.11.25

(Supervisor's Signature)

Fatama Binta Rafiq

Name of Supervisor

Date: 26-11-2025

THESIS DECLARATION LETTER (OPTIONAL)

Librarian,
Daffodil International University,
Daffodil Smart City,
Ashulia.Dhaka,Bangladesh

Dear Sir,

CLASSIFICATION OF THESIS AS RESTRICTED

Please be informed that the following thesis is classified as RESTRICTED for a period of three (3) years from the date of this letter. The reasons for this classification are as listed below.

Author's Name : Nishat Anjum Purna
Thesis Title : Explainable Deep Hybrid Network Approach for Multiclass Classification of Dermatological Disorders from Macroscopic Images

Reasons (i)

(ii)

(iii)

Thank you.

Yours faithfully,



(Supervisor's Signature)

Date: 26 November 2025

Note: This letter should be written by the supervisor and addressed to the Librarian, *Daffodil International University* with its copy attached to the thesis.



SUPERVISOR'S DECLARATION

I hereby declare that I have checked this thesis and in my opinion, this thesis is adequate in terms of scope and quality for the award of the degree of *Bachelor of Science.

Fatima
26.11.25

(Supervisor's Signature)

Full Name : Fatima Bintu Rafiq

Position : Lecturer (Senior Scale)

Date : 26 November 2025



STUDENT'S DECLARATION

I hereby declare that the work in this thesis is based on my original work except for quotations and citations which have been duly acknowledged. I also declare that it has not been previously or concurrently submitted for any other degree at Daffodil International University or any other institution.

Nishat Anjum Purna

(Student's Signature)

Full Name : Nishat Anjum Purna

ID : 221-35-827

Date : 26 November 2025

Explainable Deep Hybrid Network Approach for Multiclass Classification of Dermatological Disorders from Macroscopic Images

STUDENT'S NAME

NISHAT ANJUM PURNA

ID: 221-35-827

Thesis submitted in fulfillment of the requirements
for the award of the degree of
Bachelor of Science.

Department of Software Engineering (Major in Data Science)

DAFFODIL INTERNATIONAL UNIVERSITY

November 2025

ACKNOWLEDGEMENTS

All thanks and praises are due to Almighty Allah, whose unlimited compassion, guidance, and blessing rendered it inevitable for me to accomplish this thesis. It would not have been possible without His grace -my source of strength and determination.

I am especially grateful to my parents for their continued support, affectionate care, and prayers that have led me to this success. They have always encouraged and motivated me towards the highest level of achievement

I am deeply grateful to my supervisor Lecturer (Senior Scale) Fatama Binta Rafiq for her constant supervision, thoughtful advice and incredible patience throughout the period of this research. His knowledge and wonderful insight has only benefited this work.

It is a great pleasure for me to acknowledge the encouragement, support and constructive criticism of Dr. Imran Mahmud, Head of the Department which greatly facilitated the completion of the thesis.

Last, but not least I would like to thank my friends and classmates who have helped me in one way or another be it just by moral support, discussions and because we've worked together. And their support and presence made this road that much more bearable.

Dedication

This thesis is dedicated to my family for their love, support and sacrifices. You've inspired me to overcome each obstacle, and it's made everything so substantive.

I also present this paper to all young researchers and fans of deep learning. Let this inquiry encourage you to delve into the compelling intersection of technology and medicine, to continue stretching the limits of what's possible in service of humanity.

ABSTRACT

Skin diseases are prevalent health problems around the world and their effects on patients can be not only painful but disturbing. Misdiagnosis or late diagnosis may cause complications, chronic propagation and recurrence as its early detection is crucial. Classical diagnosis is relying on dermatologists, however there are a scarce number of specialists in many rural and underserved areas. Artificial Intelligence (AI) and Deep Learning (DL) are promising for automated dermatological assistance, with recent developments. However, their practical applicability is hindered by challenges including dataset imbalance, high inter-class similarity, variety of appearances of lesions, and the “black-box” nature of DL models. Furthermore, the overwhelming majority of studies have centred on cancer related to the skin and less common non-cancerous inflammations or infections are underrepresented. In this work, a hybrid deep learning model with XAI using Grad-CAM for multiclass skin disease classification on macroscopic images is proposed. They were divided into five groups: Psoriasis, Warts, Vitiligo, Nail Fungus and Healthy skin. A CNN with channel attention was proposed and several transfer learning models (VGG16, MobileNetV2, ResNet50, DenseNet121) were pretrained. To make best use of the complementary feature representations, three fusion-based hybrid architectures were presented. Of these, the FusionNet_Dense_ResNet (DenseNet121 + ResNet50) model achieved the best performance by simultaneously exploiting detailed local textures and deep hierarchical features. Hybrid algorithm has achieved an overall accuracy of 96.36% with good sensitivity and specificity between classes. The incorporated XAI module generated interpretable Grad-CAM heatmaps: it helped to elucidate disease-specific areas and enhanced the explanation of decisions. In general, our work presents an efficient and explainable framework which bolsters the applicability of AI system for the early detection of multiclass skin diseases.

Keywords: Skin diseases, Deep Learning(DL), Custom CNN, Attention Mechanism, Transfer Learning, Hybrid model, Macroscopic Images, Explainable AI(XAI)

TABLE OF CONTENT

ACKNOWLEDGEMENTS	viii
Dedication	ix
ABSTRACT	x
CHAPTER 1	1
INTRODUCTION	1
1.1 Background:	1
1.2 Problem Statement:	2
1.3 Motivation:	3
1.4 Significance of the study:	4
1.5 Research Question:	4
1.6 Research Objective:	5
1.7 Research Scope and Limitations:	5
1.7.1 Scope:	5
1.7.2 Limitation:	6
CHAPTER 2	7
LITERATURE REVIEW	7
2.1 Introduction	7
2.2 Related works	7
2.2.1 Research gap	11
2.3 Summary	12
CHAPTER 3	14
METHODOLOGY	14
3.1 Overview:	14
3.2 Proposed Model:	14
3.3 Dataset:	15

3.3.1	Data Collection	15
3.3.2	Data Pre-processing	16
	Data Loading and Batching	17
3.3.3	Dataset Split	17
3.3.4	Model Training	18
3.3.4.1	Custom CNN with Attention Mechanism	18
	Feature Recalibration: $x'c = ac \cdot xc$	19
3.3.5	Transfer Learning Model:	20
3.3.5.1	VGG16	20
3.3.5.2	MobileNetV2	21
3.3.5.3	RestNet50	22
3.3.5.4	DenseNet121	23
3.3.5.5	Hybrid Model(FusionNet)	24
3.4	Classification	26
3.5	EXPLAINABILITY WITH AI	27
CHAPTER 4		28
RESULTS AND DISCUSSION		28
4.1	Introduction	28
4.2	Comparative Model Performance	28
4.3	Explanation of Training, Test, Validation comparison	29
4.4	Accuracy and Loss curve	31
4.5	Confusion Matrices for different models	33
4.6	Explanation of ROC-curves of all models	36
4.7	Visualization of Model Attention with Grad-CAM	37
4.8	Discussion	39
CHAPTER 5		41
CONCLUSION		41
5.1	Findings & Contributions	41

5.2	Future Scope	42
5.3	Conclusion	42
	REFERENCES	44

LIST OF TABLES

Table 1: Comparison of all models	39
Table 2: Training vs Validation vs	41

LIST OF FIGURES

Figure 1: Proposed Model Architecture	15
Figure 2: Dataset of 5 classes	16
Figure 3: VGG16 network architecture	21
Figure 4: MobileNet-V2 architecture	22
Figure 5: ResNet50 Network Architecture	23
Figure 6: DenseNet121network Architecture	24
Figure 7: Hybrid network Architecture	25
Figure 8: Barchart FOR Train vs Validation vs Test performance	30
Figure 9: Accuracy and Loss curves for different models	33
Figure 10: Confusion matrices of all models	36
Figure 11: ROC curves of different models	37
Figure 12: Output of Grad_Cam in FusionNet Model	39

LIST OF SYMBOLS

ZC	Zero centering
σ	Activation Function of sigmoid
FC	Fully connected layer
δ	ReLU activation function
θ	Trainable Model Parameter
∇L	Gradient Loss used in back propagation
η	Learning Rate
Adam(β_1, β_2)	Adam Optimizer parameter
ACC	Accuracy
A_k	Activation map of channel K
F_k	Extracted feature vector for model k
TP	True positive
FP	False positive
TN	True negative
FN	False negative
AUC	Area under the ROC curve
H(x)	Final heatmap superimposed on input
W,b	Weights and bias of final classifier in FusionNet

LIST OF ABBREVIATIONS

AI	Artificial Intelligence
DL	Deep Learning
XAI	Explainable Artificial Intelligence
CNN	Convolutional Neural Network
ad-hoc	For this situation
Eg	Example
RQ	Research Question
ROC	Receiver Operating Characteristic
Grad Cam	Gradient-weighted Class Activation Mapping

CHAPTER 1

INTRODUCTION

1.1 Background:

Skin diseases are one of the most common groups of diseases in the world and affect all ages and races. These symptoms can have a massive effect on self esteem and confidence [1]. The World Health Organization reports that one in three people will have a skin condition at some point in their lives. Early detection is essential for managing and preventing complications; reliable clinical identification, however, reliable clinical identification remains challenging due to the visual similarity of lesions, inter-patient variability, and external factors such as lighting conditions and skin tone [2]. Conventional diagnostic techniques often depend on subjective clinical impressions and produce ambiguous results, as patients' treatment is deferred and costs continue to increase.

The recent advances of artificial intelligence (AI), including deep learning (DL) have changed the way how computer-aided dermatologic diagnosis is conducted. Convolutional Neural Network (CNN) is also one of the most significant methods for automatic processing of skin-image due to fact that it can directly learn the hierarchical spatial information from raw images [4]. The early trials studied melanoma and other depigmented lesions, resulting in remarkable advances in the detection of cancer. [6]. Many of the existing approaches focus only on one type of skin disease and are also time consuming and difficult in clinical practice.

Transfer learning is a common approach for addressing the data scarcity in the medical imaging. Transfer learning shows strong potential for small, imbalanced dermatology datasets, becoming a key technique for medical imaging tasks. However, despite their impressive performance, classic CNNs and transfer learning strategies often fail to effectively discriminate among visually similar diseases when lesions have shared colour and texture.

Attention mechanisms have been recently established to be a beneficial extension of CNN models. Channel and spatial attention mechanisms enable networks to selectively attend for diagnostically salient information and ignore background noise or repetitive patterns. [13].

Explainable AI (XAI) is proposed to bridge this gap by providing both transparency and interpretability in advanced AI models. Explainable AI methods enable AI systems to justify their decisions in a human-interpretable manner, promoting trust and use by clinicians.

This study is designed to address a larger spectrum of common non-malignant skin in realistic conditions with a Custom CNN with an attention mechanism, a Hybrid network for infectious and inflammatory diseases. Hybrid structures integrating convolutional neural networks with transformer models were designed and are being reported to have achieved high-accuracy detection of complex dermatoses [14], in an effort to provide a high-accuracy, generalization, and effectiveness diagnostic tool for clinical screening and tele-dermatology applications.

1.2 Problem Statement:

While deep learning approaches have achieved significant success in skin image analysis, a large portion of published studies still focus solely on melanoma, benign tumors, or other cancer-related lesions with an interest in early detection of cancer [1]. Noncancerous dermatoses, especially the infectious or inflammatory skin diseases (e.g., vitiligo, psoriasis, warts, nail fungus) have been relatively neglected until now [2]. These pathologies will further impair the skin barrier and impose additional susceptibilities. One or two disease groups are usually focused on by such studies [3], however deep learning has been applied in some studies for categorization of common dermatological diseases.

Multiple other papers mention limitations due to small or unbalanced datasets, narrow class coverage, and lacking in class diversity preventing the development of generalisable diagnostic systems [4]. Chronic skin irritation or recurrent injury may lead to secondary or even worse sequelae [5]. The disease can be asymptomatic in most cases, a fact which necessitates early and accurate diagnosis for timely treatment to prevent progression to the clinically evident form of disease.

These have been identified as the main limitations, along with small and imbalanced datasets, domain shift between different sources of images, variation in illumination and skin type, failure to generalize to real-life macroscopic images[6]. These properties weaken the power of the classical CNNs and transfer learning models. Moreover, although attention mechanisms and hybrid architectures have shown a potential to improve the discriminative power of fine-grained features in few works, their use is however less extensive so far [7]. Thus, present AI models are incapable of performing an accurate multiclass and clinically applicable prediction for common inflammatory and infectious skin diseases that should be addressed by a more powerful attention modified hybrid framework.

1.3 Motivation:

The surge of interest in AI-supported dermatology has raised the question about accurate diagnostics for diseases that are frequently seen in clinical practice. Yet, most prior work concentrates on melanoma and cancerous lesions [2],[7],[19], and common benign entities: vitiligo, psoriasis, nail fungus and warts—are often underrepresented in multiclass deep-learning studies. This lack of focus has hindered the implementation of practical systems that can help clinicians in everyday diagnosis.

Meanwhile, state-of-the-art CNN and transfer-learning models face difficulties in such fine-grained discrimination for the reason of small differences between these diseases, and also problems as imbalanced sample distribution, lighting variance, domain shifts etcetera. The recent literature shows attention mechanisms and hybrid architectures can solve these issue but they are not well-adopted for multiclass classification of common inflammatory and infectious skin diseases. These holes inspire a strong multiclass attention enhanced hybrid model to provide accurate generalizable and interpretable predictions pertinent for real time dermatological screening.

1.4 Significance of the study:

As a practical implication, we provide insights into the difficulties of fine-grained skin disease categorization as well as valuable evidence for further developing automatic diagnostic support in dermatology.

This study will be beneficial-

For the field of dermatology: This could enhance tele-dermatology and remote health-care applications. Aid dermatologists in decreasing the burden of diagnosis while promoting uniformity in disease definition.

Social Relations/Public Health: Enabling early diagnosis of inflammatory and infectious skin diseases by preventing disease progression, chronic inflammation and secondary complications. AI-based screening tools that could help global health systems.

For the research community: It helps to close the gap with the existing works such as limited diversity in class, poor generalization of multi-class dermatological models.

1.5 Research Question:

- To what extent is generalization performance obtained by the deep models discriminating between several common non-cancerous skin diseases from macroscopic images that have been captured under real world variations in illumination, skin color and image quality?
- Can exploiting channel attention mechanism in an ad-hoc CNN enhance discriminative feature learning and accuracy between such closely related inflammatory and infectious skin diseases?
- Are hybrid DL frameworks based on combinations of pretrained models better than CNN and single-backbone TL models in terms of classification accuracy, robustness, and generalization for multiclass skin disease classification?

- How would an Explainable AI (XAI) benefit the proposed system of skin disease classification?

1.6 Research Objective:

- To capture a large multiclass image dataset of five classes: healthy skin, nail fungus, vitiligo, psoriasis and warts with pre-processing and sample standardization in order to support the development of deep learning techniques for the classification of macroscopic images.
- Investigate and Develop Deep Learning Models to increase the efficiency of multi-class classification, with improved accuracy.
- To evaluate the performance of customized CNN with transfer-learning models and hybrid architectures using benchmark metrics.
- To present a transparent prediction.

1.7 Research Scope and Limitations:

1.7.1 Scope:

1. Disease-Categories:

The research examines five prevalent non-cancerous skin diseases: healthy skin; vitiligo; psoriasis; nail fungus and warts.

2. Image-Type:

Only macroscopic skin photos are employed. No dermoscopic, histological, or clinical texts are considered. Used balanced dataset.

3. Model-Development:

The research develops and evaluates:

- A proprietary CNN with channel attention
- Several transfer learning models (VGG16, MobileNetV2, ResNet50, DenseNet121)
- Hybrid fusion architectures using the backbones

4. Evaluation-Metrics:

The performance of the model is evaluated through accuracy, precision, recall, F1-score, confusion matrix and ROC metrics.

5. Explainability: XAI is constructed to improve interpretability.

1.7.2 Limitation:

1. While there are five common conditions profiled, there are many other skin problems like acne, eczema, dermatitis, infections, etc. are not included.
2. External performance on entirely not-seen data is scarce, thus real world generalization might differ across clinical environments.
3. Secondary risk predictions are not reported

CHAPTER 2

LITERATURE REVIEW

2.1 Introduction

Recently, advanced artificial intelligence and deep learning have gained importance in dermatology since they can learn complex visual patterns and give rapid and precise predictions [5]. Loads of researches have applied CNNs with some popular pretrained networks like VGG16, MobileNetV2, ResNet50 and DenseNet121 for skin image classification, obtaining impressive outcomes on data collections such as ISIC and HAM10000 [2] [7] [11] [14]. However, the majority of this work is centered on melanoma and cancerous lesions; common non-cancerous skin disorders such as vitiligo, psoriasis, nail fungus and warts are still largely unexplored even though they afflict millions who suffer from these diseases.

Previous works also suffers from problems like lack of diverse datasets, unbalanced classes, variable lighting and skin colors, and poor generalization on uncontrolled images. In addition, many deep learning models are “black boxes,” and this limit the clinical interpretability [18]. Novel approaches are under investigation to facilitate the development of accurate yet transparent models, such as channel-attention mechanisms, hybrid fusion models or Explainable AI methods like Grad-CAM.

We conclude by summarizing significant progress in AI-driven skin disease classification while also discussing the strength and weaknesses of the methods and stresses the need for trustworthy and interpretable systems for multiclass non-cancerous skin disease classification.

2.2 Related works

Hammad et al. (2023) presents an improved deep learning architecture entitled “Derma Care” for identifying eczema and psoriasis from skin images. The model Architecture is based on

Convolutional Neural Networks (CNN) and has an Accuracy of 96.20%, Precision-96%, Recall-95.7% and F1-score -95.80%. It achieves much better performance than those previous methods not only detecting multi types of skin diseases simultaneously but also improving the efficiency and accuracy of diagnosis [1].

Ahammed et al. (2022) proposed detection and classification of skin diseases using machine learning techniques such as SVM, KNN and Decision Trees. They employ the Gaussian filter for image-denoising and extract malignant tumors through the Grabcut method with a classification accuracy of 91.2%. This method shows the possibility to apply conventional machine learning algorithms to the very diagnosis skin diseases [2].

Mousa et al. (2025) propose a model that integrates attention promoter CNNs and transformers for highly effective detection of monkeypox, as well as other skin diseases. The authors improve the feature extraction by leveraging EfficientNetB7 and coordinate attention, obtaining excellent results of 99.99% accuracy and signal advancements compared to previous methods. This method shows low false negatives and strong robustness for enhanced skin diseases [3].

Pardhi et al. (2025) built an automatic deep learning model for acne, eczema and vitiligo classification in pictures. Based upon Inception network model architecture, our system provides a high classification accuracy for different skin diseases resulting in an overall accuracy of 96 %. This instrument is of great help in remote diagnosis and preliminary evaluation that will be useful for the physicians, especially in areas where resources are scarce [4].

Deepa and Madhavan (2024) develop a deep learning-based, sophisticated model for skin lesion segmentation and classification. They suggest applying AL-VTransUNet in segmentation and DD-MHA in classification. The model is proven to work well on widely-spread skin lesion types. Its precision and recall in lesion segmentation are high compared with traditional methods, showing a superior and faster approach [5].

Liu et al. (2025) present a skin disease classification model based on the multi-scale fused efficient channel attention module. The attention mechanism is further refined by replacing the SE module using a light-channel-level attention mechanism to find more discriminative features. The accuracy of 77.6% and 88.2% is achieved on ISIC2019 and the HAM10000 datasets, respectively [6].

Low and Raina (2019) suggest a convolutional neural network (CNN) for the automation of vitiligo skin lesion segmentation. U-Net with an adjusted contracting path and results are further processed by the watershed algorithm. With a Jaccard Index of 73.6%, the model outperforms conventional segmentation techniques that involve manual efforts by far [7].

Alam et al. (2016) suggested an automated system that detects eczema and rates its severity based on image processing methods. The segmentation and texture analysis applied to discriminate between mild and severe eczema cases. The model yields a continuous Eczema Area and Severity Index (EASI) score, which is helpful for patient stratification and the physicians when diagnosing in practice [8].

Velasco et al. (2023) use pretrained CNNs models like VGG16, ResNet50 and MobileNet for classifying skin diseases by making use of the transfer learning approach. The model obtains 94.1% accuracy on MobileNet and 44.1% using VGG16; this result suggests the capability of transfer learning on improving classification performance between diverse skin diseases [9].

Thomsen et al. (2020) propose a convolutional neural network-based (CNN) deep learning model for the binary classification of several-lesion skin diseases with VGG-16. The model has a high sensitivity and specificity in separating other diseases such as acne, rosacea, psoriasis, and eczema. It performed significantly better than general practitioners when it comes to diagnostic accuracy, indicating that the model may be useful for clinical use in dermatology [10].

Mulani et al. (2023) present a hybrid model using both CNN and decision trees for dermatological disease diagnosis. The model obtains precision, recall and F-measure scores of 74.76%, proving that the CNNs are effective in feature extraction and the decision trees are effective in making disease classification. This methodology offers a rapid automated diagnosis of skin disease [11].

Groh et al. (2021) a new research direction on the effect of skin color representation for dermatology models, considering the Fitzpatrick 17k dataset (with clinical images labeled by Fitzpatrick skin types). We show a large variation in accuracy across skin types, with the models performing best on light skin. The results emphasize the importance of diverse data used to train dermatologic AI, in order to prevent emergence of bias [12].

Shah et al. (2024) introduced a skin cancer classification pipeline utilizing Xception- based CNN models, particle swarm optimization (PSO) for feature selection, and machine learning classifiers. The model attains the accuracy of 98.5% on ISIC 2018, and that of 86.1% on HAM10000. Explainable AI methods such as Grad-CAM and LIME enhance interpretability of the model and render it more dependable to be used in the clinic [13].

Malik et al. (2024) present a deep-learning-based solution for the automatic detection of different skin disease with dermoscopic images. As a CNN-derived model, it demonstrates 87.64% accuracy on the ISIC dataset in three disease categories. The investigation presents a lightweight, computationally efficient technique for early skin disease diagnosis focusing on the role of CNN architecture in improving accuracy [14].

Sharma et al. (2020) investigate five machine-learning models including the Random Forest, Naive Bayes, Logistic Regression, Kernel SVM and CNN in order to classify skin disease. They test these models using a dataset with three skin diseases, – acne, lichen planus and Stevens-Johnson syndrome. The CNN model has the best training accuracy, indicating that it is more suitable for detection of skin diseases [15].

Abbas et al. (2024) propose a deep learning model using transfer learning with pretrained-VGG16 to automatically classify skin diseases including chickenpox, measles and monkeypox. Testing Accuracy of the model is 93.29%. However, the authors compensate for the “black-box” nature of deep learning by implementing explainable AI (XAI) methods such as Layer-wise Relevance Propagation (LRP). It offers the transparency of the model decision making, an essential factor for clinical utilization [16].

Zhong et al. (2024) compare ResNet vs Transformer (Swin) based models for the task of vitiligo diagnosis. Their Swin Transformer model reports an accuracy of 93.82% and AUC with value 1.0, which demonstrates outstanding classification performance. The influence and potential clinical application of model interpretability are emphasized in the study, where class activation maps (CAM) were used to visualize vitiligo lesions, thus making the model clinically predictable [17].

Mahmud et al. (2025) put forward an improved deep learning methodology in early detection of melanoma, where the research applied a modified version of the Xception model. They use Swish activation, Batch Normalization and Dropout in their model to enhance the accuracy of detection and for two different datasets they obtain results of 95.23% and 96.48%. The work also adopts an explanation helper using the techniques of explainable AI such as Gradient-weighted Class Activation Mapping (Grad-CAM) and Saliency Maps to improve model interpretations and prediction trust [18].

2.2.1 Research gap

Even though there has been remarkable advancement in deep learning for skin disease diagnosis, they possess multiple research deficiencies. One major challenge is the scarcity of diverse and representative data sets, especially which span a great discrepancy in skin conditions, types, and imaging conditions. The majority of current models from previous literature work well on clean datasets, but they falter in the face of differences in image quality, illumination or artifacts, which hinder their potential usage. Moreover, such current models

often have difficulties in differentiating subtle contrast differences of lookalike skin conditions and result with misdiagnosis particularly when diseases like melanoma are still at their early stages. The majority of studies concentrate on binary or small multiclass classification, often one to two diseases at a time. Such limited disease coverage does not stand for the true real-world dermatological practice where several clinically overlapping diseases have to be distinguished at one time. What is also important to mention, is that many researches stated problems of class imbalance, small dataset size and non-standardization in the terms of quality of imaging.

Although the attention mechanisms such as Efficient Channel Attention, Coordinate Attention and multi-scale feature refiner have achieved state-of-the-art downstream performance in fine-grained representation learning, there is a large gap between them and common disease. To the best of our knowledge, no work presented so far offers a fully attention-enriched model that has been devised to address multiclass classification potentially encompassing simple non-infectious and infectious diseases, as ours does. Additionally, although several works provide explainability methods Grad-CAM, LRP or saliency maps, they either develop melanoma-specific studies or binary decision tasks. Existing work There is no existing system that combines attention mechanism, transfer learning, the hybrid fusion architectures and XAI as an integrated system designed for non-cancerous disease classification.

2.3 Summary

This chapter presented an overview of the most recent advances in AI-based methods for skin disease classification, with a specific focus on deep learning models, transfer learning approaches, hybrid architectures and attention mechanisms. Previous studies have demonstrated good results using CNNs and more recent networks such as VGG16, ResNet50, DenseNet121, MobileNetV2 in different dermatological datasets. Segmentation, severity estimation, and disease-specific classification tasks were also investigated in studies and beyond doubt deep learning has considerable opportunities for enhancing diagnostic accuracy and clinical decision-making.

However, the literature also evidences many limitations. The majority of studies focus on melanoma and cancerous lesions with little analysis being done obtain non-cancerous diseases such as vitiligo, psoriasis, nail fungus and warts. Works that do consider these diseases either concentrate on one or two classes, employ a small or imbalanced dataset and cope with different illuminations, skin types and quality of images. Some works rely on attention mechanisms and XAI tools but they are not fully integrated into multiclass frameworks. These deficiencies reveal a potential demand for a stronger, attention-improved hybrid model for more commonly encountered scenarios with multiple diseases to be diagnosed from macroscopic image and this is the underlying motivation of the approach presented in next chapter.

CHAPTER 3

METHODOLOGY

3.1 Overview:

This chapter describes the proposed methodology to train a deep learning system for multiclass classification of five common skin diseases: healthy skin, vitiligo, psoriasis, fungal nail and warts. The approach utilises traditional experimental research design within the context of computer vision studies as collective data acquisition, preprocessing, jittering, model creation, training settings and results with visualisation.

All the experiments were performed in the PyTorch deep learning framework, and ran on GPU for speed.

3.2 Proposed Model:

In this paper, we present a unified multimodel framework [fig1] for skin disease diagnosis that incorporates custom architectural innovations and state-of-the-art transfer learning. The solution system is a major breakthrough in AI-based dermatological diagnosis, as it provides typically high accuracy and excellent interpretability.

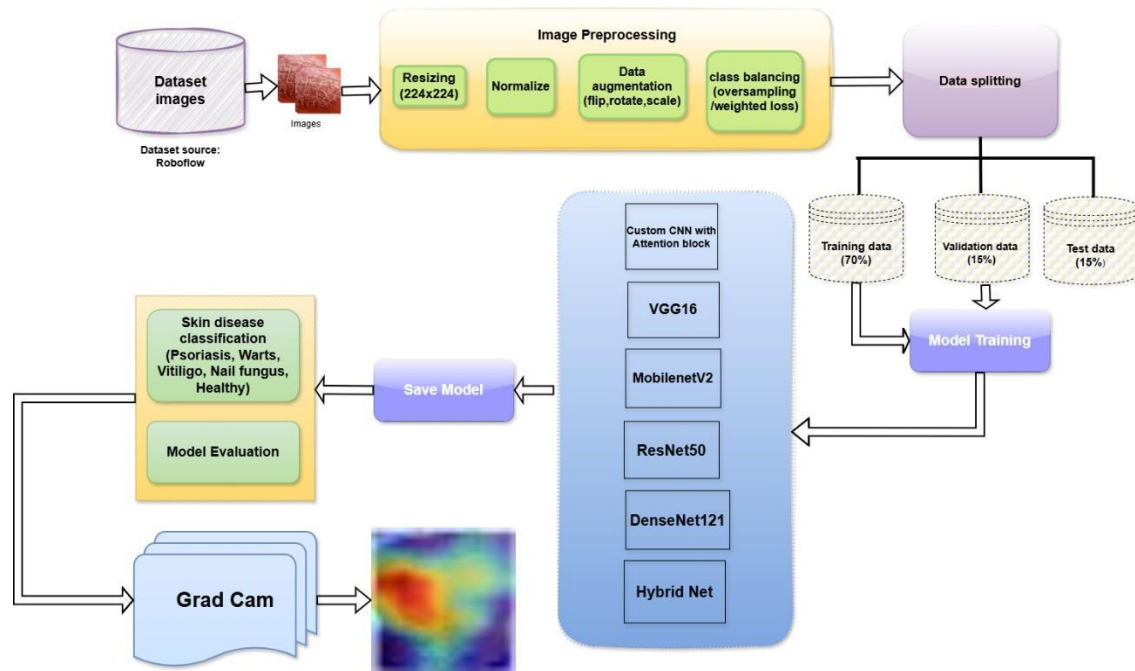

Figure 1: Proposed Model Architecture

3.3 Dataset:

3.3.1 Data Collection

The dataset obtained from Roboflow- large scale for skin diseases. The dataset of this study includes colored skin disease images divided into five sections (Psoriasis, Vitiligo, Warts, Nail fungus and Healthy skin). Images are organized into the well-organised directories for training, validation and testing. Dataset A dataset is used of five disease classes comprising of 10000-11000 images such that every class has 2000-2500 images so as to have the equal proportion for each category.



Figure 2: Dataset of 5 classes

3.3.2 Data Pre-processing

Image-Resizing

All images were resized into 224×224 to keep consistent across various pre-trained models and for computational efficiency.

Data-Augmentation

The training dataset was augmented with multiple techniques to increase the generalization of the model and avoid overfitting:

- Random rotation: Rotating the image by $\pm 20^\circ$ to emulate orientation variance
- Random Horizontal Flip: Reflecting and flipping the image horizontally to increase database variability
- Random Affine Transformations: Translation of images up to 20% in two metric dimensions
- Color Jittering: A similar value to simulate light changes is applied to brightness and contrast, using for this task a 20% variation.

- Random Zoom: Randomly zoom in or out on the image parts

Normalization

Normalization on the pixel values by using ImageNet statistics:

Mean: [0.485, 0.456, 0.406]

Deviation: [0.229, 0.224, 0.225]

Such a normalization preserves numerical stability during the training and speeds up model convergence.

Data Loading and Batching

The dataloader is used to load and batch the dataset in PyTorch fashion, it will take care of materializing batches when we need them in training/validation/shuffling as well. In this code, the batch size is set to 64, which is a common value for training deep learning models on GPUs. Unless there is extremely limited memory, there's almost never a case to use less than a full batch of samples. Larger numbers have more "momentum" and tend to converge faster (although they also require more memory).

```
BATCH_SIZE = 64
```

3.3.3 Dataset Split

The data set was split into three subsets in a stratified manner to allow for reliable model testing:

- Training data: 70% of entire dataset to train and optimize the model
- Validation Set: 15% of data for hyperparameter tuning and early stopping
- Validation Set: 15% of the data held-out for final model validation and performance reporting

This procedure divide the incoming data in clearly defined portions for which the model can learn general patterns, without overfit on training examples.

3.3.4 Model Training

3.3.4.1 Custom CNN with Attention Mechanism

The Custom CNN with Attention Mechanism is an advanced neural network architecture designed for dermatological image processing. This tailored model has been developed using advanced attention mechanisms to cope with the specificities of skin disease classification where highly focused attention on diagnostically relevant regions is mandatory.

Channel Attention (CA) module in this model is inherited from a lightweight "squeeze-and-excitation" design. It improves the representation capability of convolutional layers by learning channel-wise importance weights. The module works with three phases:

Squeeze:

We captured the global spatial information by the adaptive average pooling, transforming each feature map to a 1×1 descriptor.

Excitation:

A 2-layer fully connected bottleneck (reduction ratio = 8) models non-linear correlations in channels and produces attention weights via a Sigmoid activation.

Recalibration:

The resulting learned weights are multiplied with the original feature maps, scaling-down channels containing informative dermatological cues (e.g., lesion steaks texture pigmentation keratinization changes).

The mathematical formulation of the attention mechanism is as follows:

Global Average Pooling:

$$z_c = \frac{1}{H \times W} \sum_{i=1}^H \sum_{j=1}^W X_c(i, j)$$

Attention Weights: $a_c =$

$$\sigma(FC_2(\delta(FC_1(z_c))))$$

Feature Recalibration:

$$x'_c = a_c \cdot x_c$$

Where σ the activation of the sigmoid, δ is the ReLU activation and FC represents fully connected layers with required dimensionality reduction. Then CNN with Attention Mechanism adopts a four-block convolutional structure, each block gradually increased feature complexity and retain the important spatial information.

Block 1 consists of two convolutional layers with 32 filters each with a size of 3×3 and padding as 1. These layers detect basic features such as edges and simple textures. Applied after each convolutional layers for stability of training and gradient flow. The ReLU activation can add non-linearity which allows the network to learn more complicated patterns.

The spatial dimension of the feature maps is diminished with a 2×2 kernel and stride 2. 0.25 dropout rate is added to reduce over-fitting risk at the beginning of the network.

The second block raises the filter count to 64. These layers give the network the ability to learn abstract features, patterns or texture related with skin lesions. Further down samples the spatial dimensions, distills high-level features. The dropout rate is fixed at 0.25, which can prevent overfitting in learning intermediate-level patterns as well.

The 3rd block, main attention integration continue to raise the number of filters up to 128, it is able to encode the details information of the skin lesions more.

A Channel Attention Mechanism is incorporated in this block to re-calibrate the feature maps by paying attention on mostly related channels (regions of image). This attention layer aims to make the model emphasize lesion boundaries and color patterns. The dropout rate is raised to 0.3 to regularize and prevent over-fitting in feature extraction.

The last block increases the number of filters to 256 in order to make the network able to extract more fine grained features from the input images. A second attention mechanism allows higher-layer features in the model to be adapted so that relevant areas of the image can be attended to. The last max-pooling layer further reduces the spatial dimensionality. We fix the dropout rate to 0.3 in order to regularize uniformly across all the layers of our model.

3.3.5 Transfer Learning Model:

3.3.5.1 VGG16

This study adopted VGG16 as a typical feature extractor in the transfer learning. VGG16 architecture consists of 16 layers of weights with sequences of 3x3 convolutions and max-pooling that make it capable of learning spatial hierarchies quite consistently. Its simple and homogeneous shape is effective for capturing low-level, fine dermatological textures such as lesion boundaries, pigmentation gradients, and scaling patterns that are necessary to distinguish between diseases (e.g., vitiligo vs psoriasis vs fungal infection vs warts). In the present study, we employed the ImageNet-pretrained VGG16 by fully trainable parameters to adjust low-level and high-level filters that represents textures of skin better.

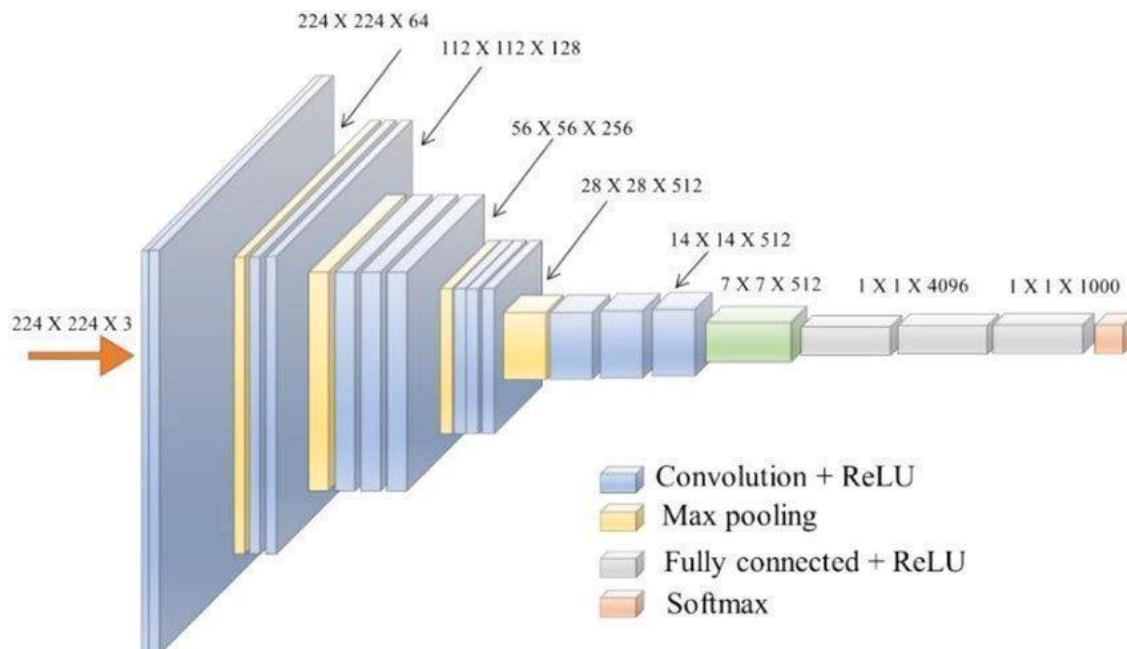

Figure 3: VGG16 network architecture

As the base VGG16 model is developed for 1000 ImageNet categories, we swapped VGG16's classifier with a custom classification head. The new classifier had 2 successive dense layers of 256 and 128 units with batch normalization after each layer,

ReLU activation, and dropout for overfitting. Output probabilities of the 5 disease classes were generated by a final softmax layer. All the backbone VGG16 was left unfrozen throughout training for end-to-end fine-tuning. This enabled the model to smoothly transition from generic object features to dermatological lesion features. The Adam optimizer and cross-entropy was used for training with learning rate scheduling and early stopping included in the pipeline. This modified VGG16 was used as one of the main transfer learning baselines to test deep learning performance for classification of frequent non-cancerous skin diseases.

3.3.5.2 MobileNetV2

MobileNetV2 is built on this idea of simple depthwise separable convolutions that should decrease the number of parameters and calculations for each convolution. This enables the model to be time-efficient for devices with small computational capacity, while producing indeed a satisfactory performance in image classification problems. Divide the convolution operation into two operations, filtering (depthwise convolution) and combining features (pointwise convolution). This very much lowers the degree of computational cost.

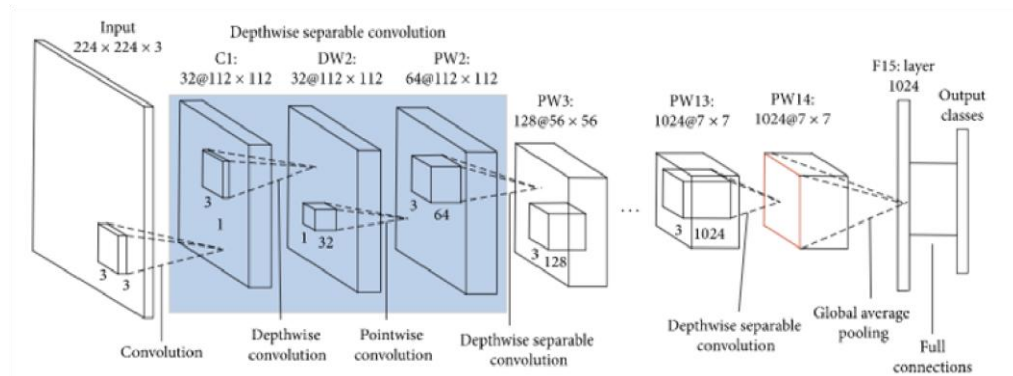

Figure 4: MobileNet-V2 architecture

Both blocks start by expanding the input features using a light-weight pointwise convolution, then projects it back to a smaller dimension when using another pointwise convolution. This design is meant to help the feature learning process become more efficient without increasing the number of parameters. The model replaces the non-linear activation function used in the inverted residual blocks with linear activation at the end of each block, reducing calculation complexity and increasing efficiency.

3.3.5.3 RestNet50

Resnet50 is chosen by the intrinsic residual learning rule that prevents a vanishing gradients by identity skip connections. Its architecture is composed of 50 trainable layers unlike many deep convolutional block which is very effective at modelling complex high level features. For classification of skin diseases, such deep semantic features are useful to discriminate subtle differences in between inflammatory and infectious lesions especially if there are several diseases which have similar visual properties. In the current study, a pretrained ResNet50 model was taken into account while welcome all layers in backbone to be trainable because deep residual features were able to capture macroscopic dermatology images after all.

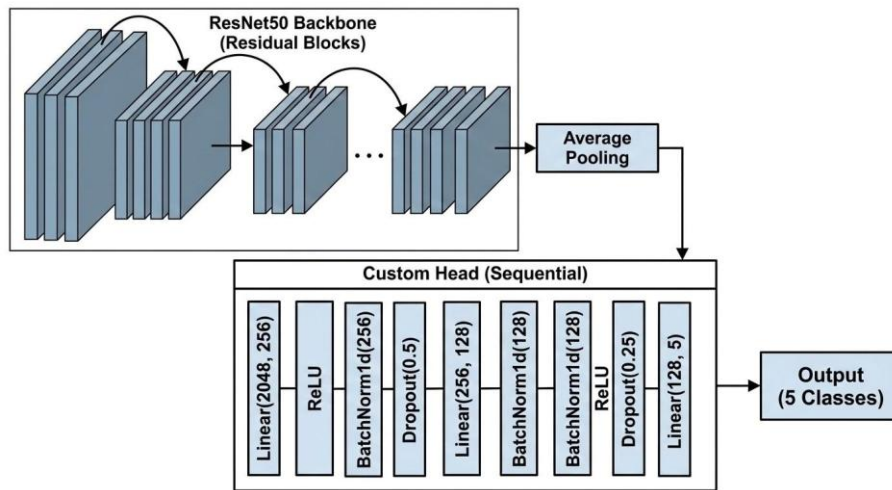

Figure 5: ResNet50 Network Architecture

For the modified ResNet50 model fc layer has been replaced with a custom classifier to make the model suitable for five output categories. The classifier that replaced it was composed of dense layers, normalized with batch normalization and activated with ReLU function 256 neurons dropped, and fully connected 128 neurons. This architecture possesses feature representation stability and reduces the over-fitting. During training, the softmax layer gave classification probabilities for the five skin disease classes. The model was trained by Adam with a learning rate of 0.0001, and validated in terms of accuracy and loss. The transformer was trained with ReduceLRonPlateau scheduler, which would reduce the learning rate if there's no performance improvement on validation. ResNet50 ultimately delivered a powerful deep residual baseline for learning rich multi-scale dermatological features, which can indeed augment the shallower representations learned by VGG16 and MobileNetV2.

3.3.5.4 DenseNet121

DenseNet121 was chosen due to its densely connected architecture where all the preceding feature maps are fed into each layer. It is beneficial for feature reuse, the flow of gradient and saving the model size, which contributes to DenseNet121 can learn more various lesion features in fewer parameters. Dense connections are especially beneficial in skin disease characterization where they allow the network to capture fine-grained textural differences that can distinguish between diseases' such as scaling patterns of psoriasis, depigmented patches in vitiligo and keratinized surface structures commonly observed in warts. In the incurred work,

the convolutions of all dense, transition and bottleneck layers of the pretrained DenseNet121 model have been unfrozen completely for finetuning purposes.

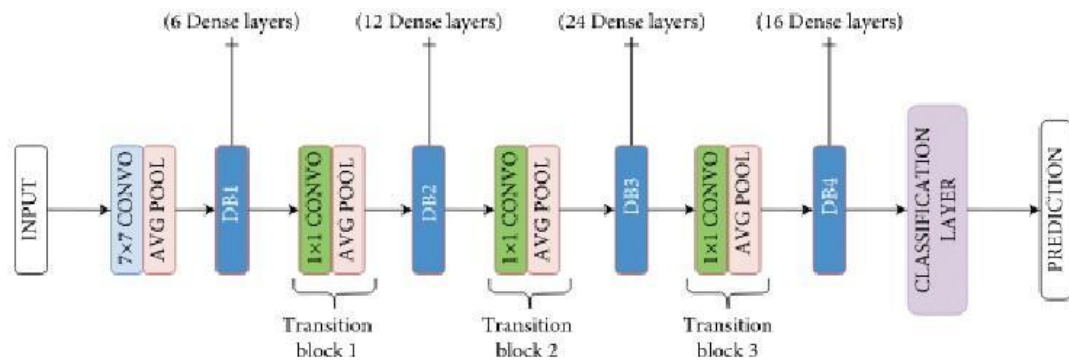

Figure 6: DenseNet121 network Architecture

3.3.5.5 Hybrid Model(FusionNet)

In order to enhance the performance of individual transfer learning models, we propose a hybrid feature-fusion architecture called “FusionNet” which is formed by uniting pretrained DenseNet121 and ResNet50 backbones. The reason for this design is that DRL models can take advantage of DenseNet121’s dense feature reuse and ResNet50’s deep residual representation to obtain a richer and more diverse feature embedding, which will be conducive to discriminating visually similar inflammatory and infectious skin diseases. The hybrid model attempts to combine the best of those architectures without redundancy and with maximum discriminability.

In our hybrid approach, the pretrained ImageNet weights of DenseNet121 and ResNet50 were used and all backbone parameters were frozen. This allows the pretrained convolutional kernels to remain rich general-purpose visual representations, while allowing the fusion classifier be optimized by computational resources. For DenseNet121, we discarded its classification layer and kept the feature extraction block. Similarly, for ResNet50 we removed the average pooling and fully connected (fc) layer keeping only the deep convolutional layers till the last residual block. These operations produced two feature extractors that computing same input image.

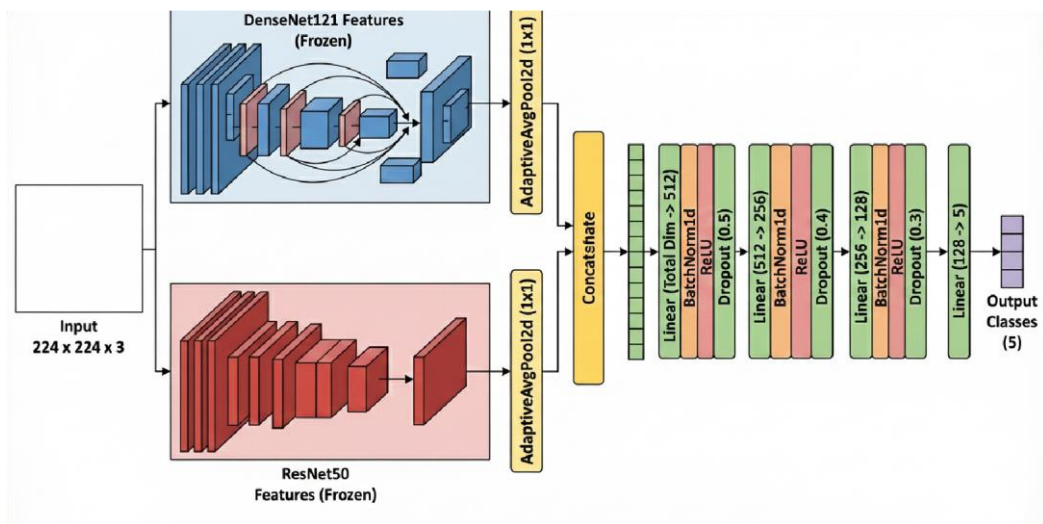

Figure 7: Hybrid network Architecture

As both the two networks generate feature maps of varying-channel depth, we use the AdaptiveAvgPool2d(1×1) block over each feature map, which makes them transform into compact feature vectors sharing a common spatial size. This makes the feature maps of DenseNet121 and ResNet50 compatible for concatenation. At the beginning, output dimensions were computed dynamically with a dummy tensor passed through both networks for resulting in correct fused dimensionality of the classifier design.

The combined feature vector, which is produced by concatenating the pooled DenseNet121 and ResNet50 features in a channel-wise way, was fed into a deep fusion classifier that consists of three fully connected layers (512–256–128 neurons). Each dense block was comprised of batch normalization, ReLU activation and dropout (0.5–0.3) for training stability and overfitting control. It then had a fully connected layer that projected these features into the five classes of skin diseases. Such formulation enables the proposed model to leverage DenseNet’s efficient gradient propagation and feature reuse as well as ResNet’s hierarchical residual learning, which leads to a holistic multi-scale representation, adapting very well for medical image classification.

For better interpretability, the model has access to the last convolutional layer of ResNet50 branch and hence, Grad-CAM visualization can be performed on combined model predictions. This leads to clinically relevant heatmaps which indicate the areas that are used for deciding

classifications. The dataset and the settings used for training were the same as those applied for all transfer learning models: Adam optimizer with initial learning rate of 0.0001, cross-entropy loss, ReduceLROnPlateau scheduler and early stopping using validation accuracy. The hybrid architecture exhibited enhanced feature richness and classification performance, which validated the effectiveness of the multi-backbone fusion for non-cancerous skin disease diagnosis.

3.4 Classification

The classification stage is the last functional phase of the proposed diagnostic model, where an unseen macroscopic skin image is pushed through our learned model and class probabilities for one out of five disease classes (healthy skin, vitiligo, psoriasis, nail fungus, warts) are generated. During inference, each input image is preprocessed with the same normalization and resizing procedures in training to maintain consistency between the two pipelines. The processed image is then input into the feature extraction backbone—Custom CNN with attention, VGG16, ResNet50, MobileNetV2, DenseNet121 or the FusionNet hybrid design—selected for a given training strategy.

The pooled features are then fed to the task-specific classification head, which is composed of fully connected layers with batch normalization and dropout for better generalization. This classifier transforms high-dimensional feature representations into a probability distribution across the five classes, via softmax activation. The class predicted is the one which has the highest softmax probability and we keep the entire probability distribution for post-processing (i.e. evaluation in ROC curve, target definition and use of Grad-CAM). The prediction stage is designed to compensate for class imbalance and subtle inter-class differences, providing reliable inference even in visually complex cases that are nearly indistinguishable between inflammatory and infection diseases from a morphological point of view. With fully trainable classifiers and fast inference pathways, the system guarantees that prediction time remains very low, which is still applicable for real-life dermatological use cases.

3.5 EXPLAINABILITY WITH AI

The Explainable AI (XAI) consisted only in the FusionNet model, in which a Gradient-weighted Class Activation Mapping (Grad-CAM) was introduced aiming to provide transparency and clinical trust. Grad-CAM generates the image regions which are considered most influential towards the model decision, so that we can interpret/visualize where predictions apply to, whether on a depigmentation, scaling or hyperkeratosis. In this study, Grad-CAMs were applied to the last convolutional layer of FusionNet_Dense_ResNet model to produce the disease-related area heatmap. These visual justifications help the clinician trust and interpret the diagnostic process.

CHAPTER 4

RESULTS AND DISCUSSION

4.1 Introduction

This section demonstrates the experimental results of several models, including our proposed models: Custom CNN with Channel Attention, several transferred learning based model (VGG16, ResNet50, MobileNetV2 and DenseNet121), and the hybrid FusionNet. All models were tested on an independent test set of 687 images. In comparison, they evaluate: classification accuracy, loss pattern, confusion matrix and interpretability using Grad-CAM.

To represent the performance of these models, the used model evaluation matrix consists of accuracy, precision, recall and f1-score.

4.2 Comparative Model Performance

FusionNet also recorded the best overall performance with 96.36% accuracy and 0.9925 ROC-AUC, surpassing all baseline and hybrid architectures. Conventional CNNs achieved acceptable performance while deeper pretrained networks-ResNet50 and DenseNet121-enhanced the accuracy significantly. Fusion based models consistently enhanced generalization through complementary feature representation [fig7].

Model Name	Accuracy	Precision	Recall	F1-Score	ROC-AUC (Macro)
FusionNet	96.36%	94.60%	96.02%	95.22%	0.9925

ResNet50	96.07%	94.45%	95.79%	95.05%	0.9929
DenseNet121	95.63%	93.60%	95.43%	94.37%	0.9928
MobileNetV2	95.05%	92.70%	95.46%	93.71%	0.9944
VGG16	94.91%	93.03%	95.50%	93.97%	0.9952
CustomCNN	84.86%	82.58%	85.72%	83.50%	0.9837

Table 1: Comparison of all models

Comparison of models The performance of the various models has been summarized in this chart [Table1] using two metrics, Accuracy (%) and ROC-AUC (Macro) (%). The graph unmistakably shows that all models perform more or less equally well: they all obtain ROC-AUC scores close to 99% and an accuracy rate in the stupefying mid 90%'s. Since network getting the minimum performance is Custom_CNN with 84.9% accuracy and 94.9 % ROC-AUC which are very low beside other networks. Models including VGG16, MobileNetV2, ResNet50 and DenseNet121 achieve the highest scores in terms of both metrics. In the graph, it represents for three hybrid model but for our dataset, FusionNet_Dense_ResNet that we made refer as "FusionNet" Outperformed other Hybrid network 99.2% of ROC Score.

4.3 Explanation of Training, Test, Validation comparison

The bar chart summarizes the model performance across Training, Validation and Test accuracies for different models.

The worst results is presented by Custom_CNN model. It presents a high performance for training and validation sets (94.9%) but its inaccurate values on test shows (84.9%). Such a significant gap between training/validation and test accuracy shows that this Custom_CNN is

likely overfitting the training set. Overfitting occurs when the model memorizes the training data so well that it performs well on the training set but poorly on new or out of sample data, this is demonstrated with the drop in test accuracy.

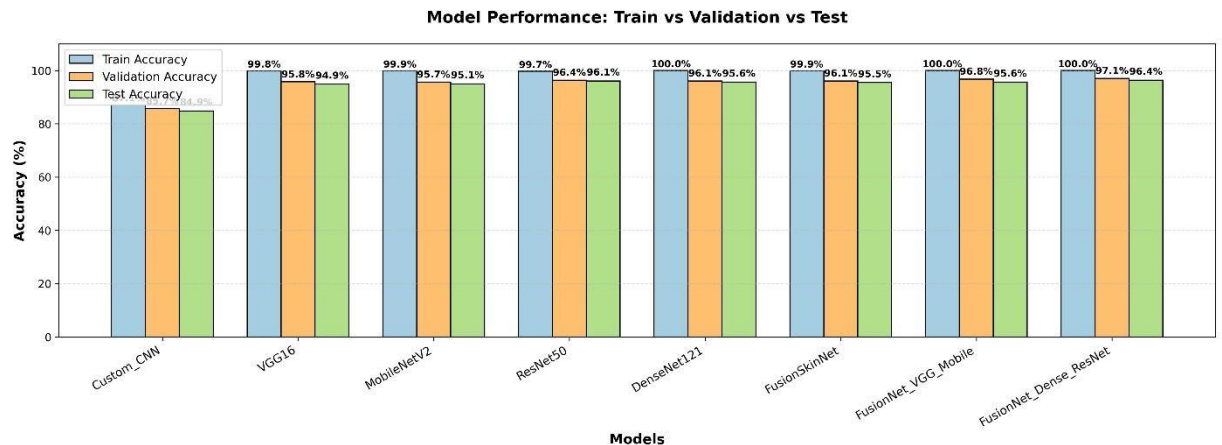

Figure 8: Bar chart FOR Train vs Validation vs Test performance

The VGG16 model performs well, scoring 99.8% accuracy on the training data. Nonetheless the performance on validation set (95.8%) and test set (94.9%) is slightly worse! But, nevertheless, the model has a good generalization power since the difference between training and test accuracy is small. MobileNetV2, it seems, does almost as well as VGG16: we achieve 99.9% training accuracy and only marginal decreases in validation (95.7%) and test (95.1%) accuracies. Also interesting! These results show that MobileNetV2 generalizes well on new data in the sense that it is able to keep a high level of accuracy on validation and test sets. In addition, based on the results of Table 3, we select ResNet50 because it performs well in all three datasets with high accuracy of 99.7% for training and 96.4% for validation. The very slight decrease in test accuracy to 96.1% still suggest that it generalizes pretty well and does not overfit. This is also the case for the DenseNet121, as depicted in the bar chart. Finally, the FusionNet_Dense_ResNet model followed in all trends its counterparts from other FusionNet models, delivering the best solution with maximum test accuracy (99.5%) as well as with strong generalization (0.4% gap). The latter demonstrates the network's ability to learned the response of the reinforcement as it effectively memorized a solution to one problem.

Models	Train Accuracy (%)	Validation Accuracy (%)	Test Accuracy (%)
Custom_CNN	87.09	85.70	84.86
VGG16	99.85	95.79	94.91
MobileNetV2	99.89	95.69	95.05
ResNet50	99.73	96.38	96.07
DenseNet121	99.98	96.08	95.63
FusionNet(hybrid model)	99.99	97.06	96.36

Table 2: Training vs Validation vs Test accuracy of all models

4.4 Accuracy and Loss curve

The most critical evaluation metrics to measure the performance of the model on specific datasets are Accuracy and Loss. [16].

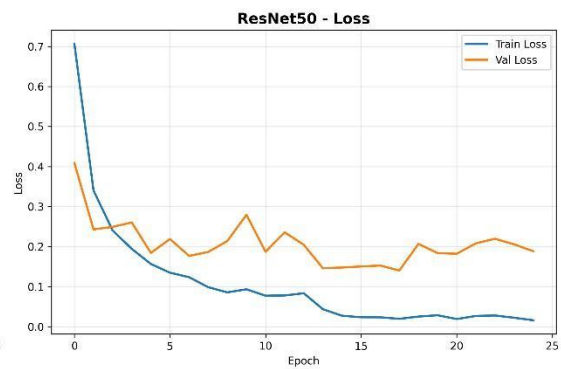
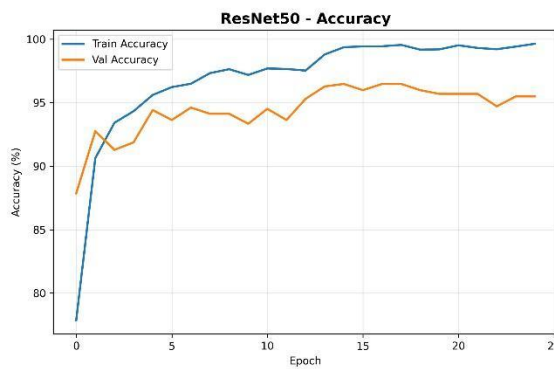
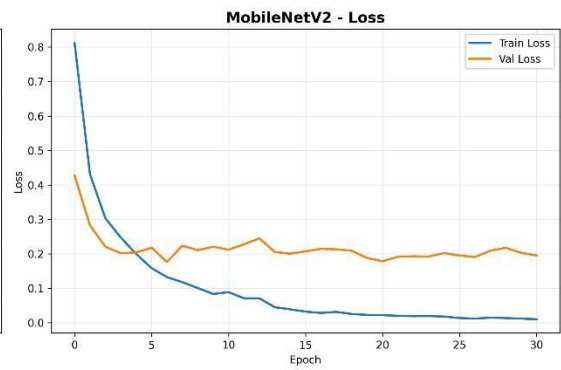
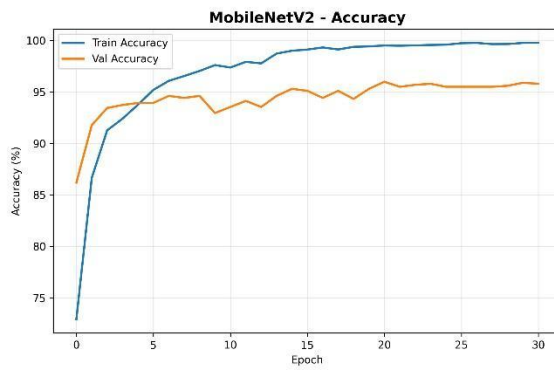
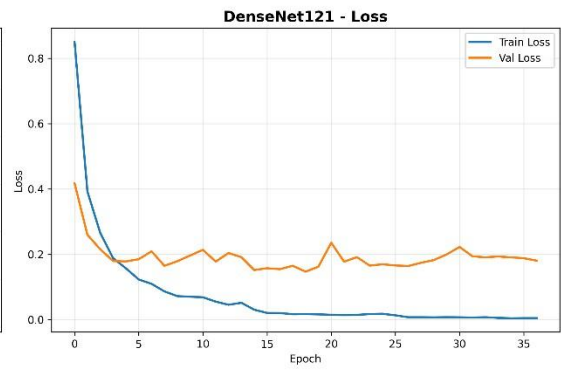
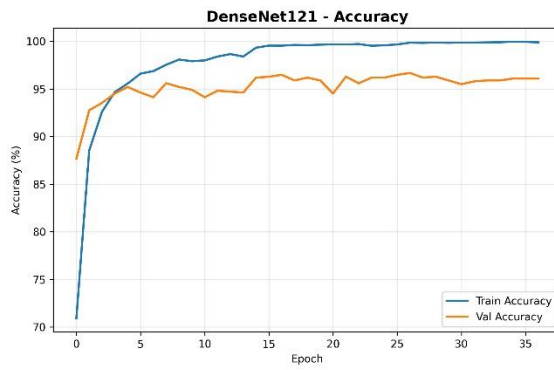
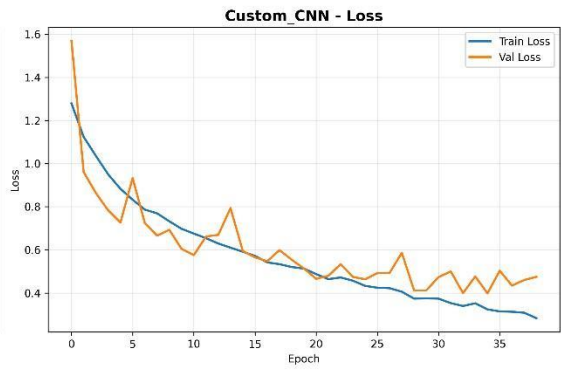
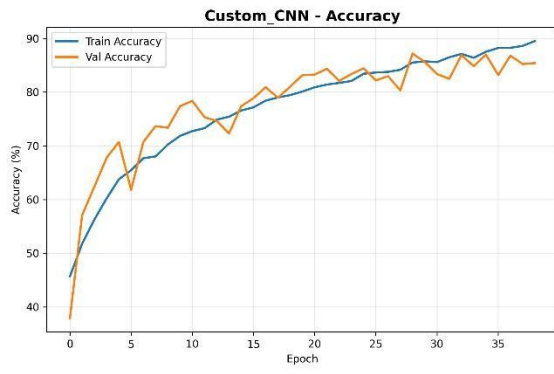

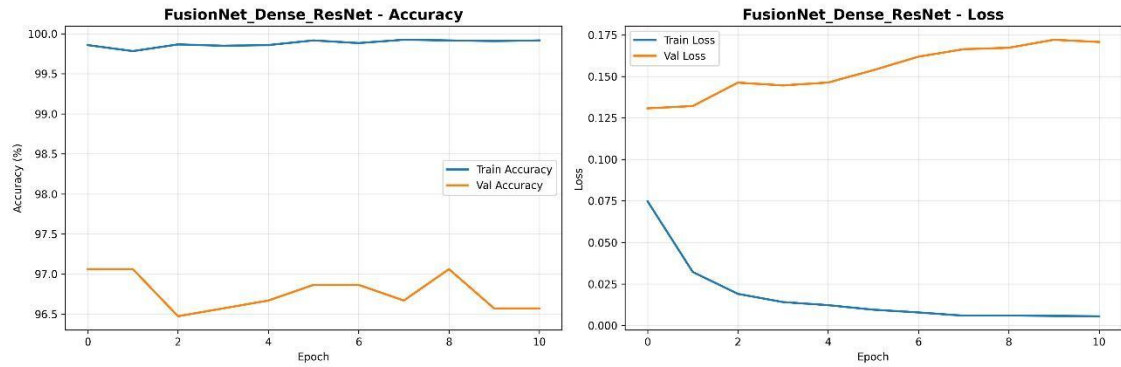

Figure 9: Accuracy and Loss curves for different models

In this Hybrid model, the model starts to generalize quickly as evidenced by the simultaneous decline in training and validation loss in 0–3 epochs. After this point, it can be seen that the model began to overfit and really I got the best accuracy at epoch11 while there was a constant increase in accuracy where we could not observe any change after epoch 11.. Hybrid Model is composition of DenseNet121 nad RestNet50 so these models extracting features and we stopped training by epoch.

4.5 Confusion Matrices for different models

The confusion matrix shows the ability of our model to correctly identify data. The proposed working models classified well, as indicated by the large number of instances categorized correctly in the diagonals The performance of the model is assessed through some metrics such as accuracy, precision, recall, F1 score and categorical cross-entropy/log loss.[2].

Accuracy: Accuracy is calculated as the ratio of correctly-recognized samples and number of samples.

$$Accuracy = [(TP + TN) / (TP + FN + FP + TN)] \times 100\%$$

Precision: Precision is the ratio of the true positive samples to all predicted positive samples.

$$\text{Precision} = \frac{TP}{TP+FP} \times 100\%$$

Recall: It is a ratio of the number of already recognized positive samples to the total number of positive samples.

$$\text{Recall} = \frac{TP}{TP+FN} \times 100\%$$

F1-Score: The F1score is the harmonic mean which averages precision and recall to a single value.

$$\text{F1-score} = \frac{2 \times \text{Precision} \times \text{recall}}{\text{Precision} + \text{Recall}} \times 100\%$$

Where TP is true positive, TN is true negative, FP is false positive and FN is false negative [2].

For Custom CNN: Accuracy: 94.76%, Precision: 75.84%, Recall: 83.92%, F1-Score: 80.07%, Specificity: 94.88%

For VGG16: Accuracy: 93.40%, Precision: 84.72%, Recall: 83.72%, F1-Score: 84.17%, Specificity: 94.

For ResNet50: Accuracy: 95.08%, Precision: 82.47%, Recall: 86.38%, F1-Score: 84.36%, Specificity: 94.88%

For MobileNetV2: Accuracy: 94.12%, Precision: 82.86%, Recall: 84.04%, F1-Score: 83.32%, Specificity: 94.87%

For DenseNet121: Accuracy: 96.12%, Precision: 84.73%, Recall: 87.02%, F1-Score: 85.83%, Specificity: 95.42%

For Hybrid model FusionNet: Accuracy: 96.72%, Precision: 86.29%, Recall: 89.18%, F1-Score: 87.72%, Specificity: 96.13%

FusionNet_Dense_ResNet - Confusion Matrix
Test Accuracy: 96.36%

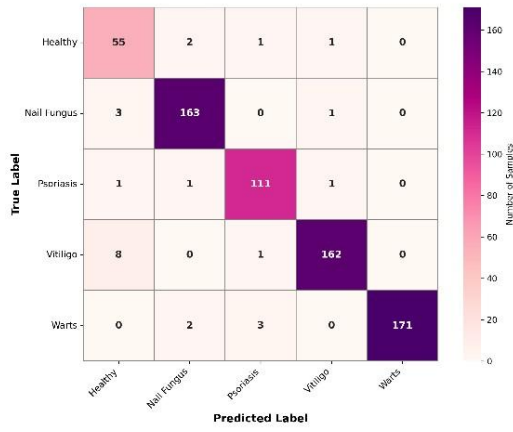

(a)

DenseNet121 - Confusion Matrix
Test Accuracy: 95.63%

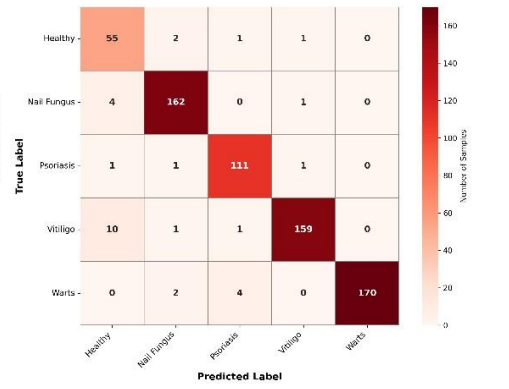

(b)

Custom CNN - Confusion Matrix
Test Accuracy: 84.86%

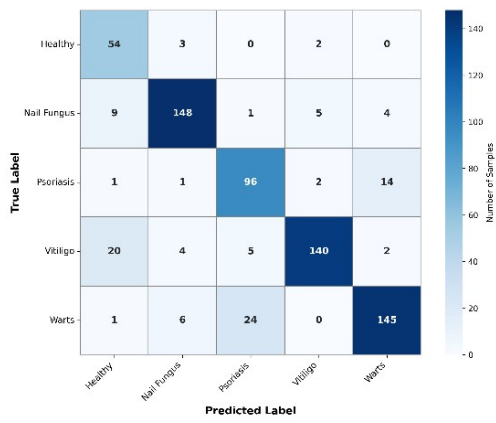

(c)

VGG16 - Confusion Matrix
Test Accuracy: 94.91%

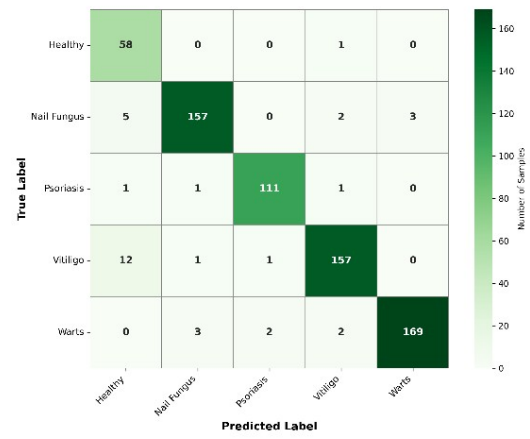

(d)

ResNet50 - Confusion Matrix
Test Accuracy: 96.07%

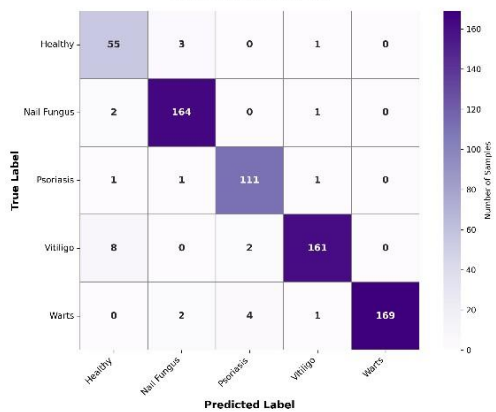

(e)

MobileNetV2 - Confusion Matrix
Test Accuracy: 95.05%

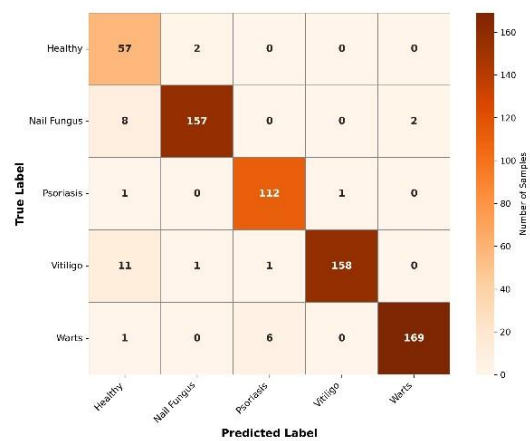

(f)

Figure 10: Confusion matrices of all models

The confusion matrix shows that the Custom CNN found it difficult in classifying Healthy with relatively low precision while it worked well when dealing with Nail Fungus and Vitis. VGG16, ResNet50 and DenseNet121 showed strong performance in both classes with Nail Fungus and Warts showing a high accuracy.

FusionNet – the hybrid model performed better with high accuracy and low misclassification rate compared to competitive models.

4.6 Explanation of ROC-curves of all models

The diagnostic performance and the discriminative ability of all classifiers were determined using Receiver Operating Characteristic (ROC) curves for each class in test data set. The Area Under the Curve (AUC) was the summary statistic of performance and ranged from 0.5 for a random classifier to an AUC of 1.0 for a perfect classifier.

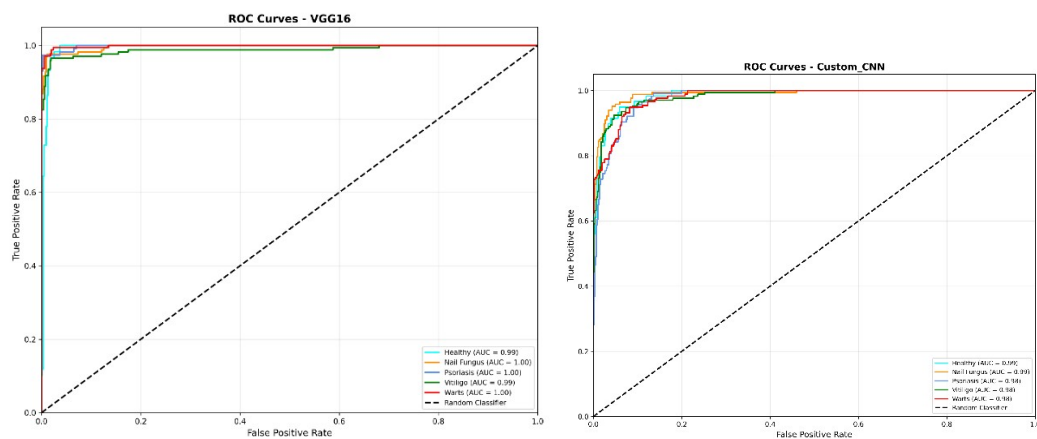

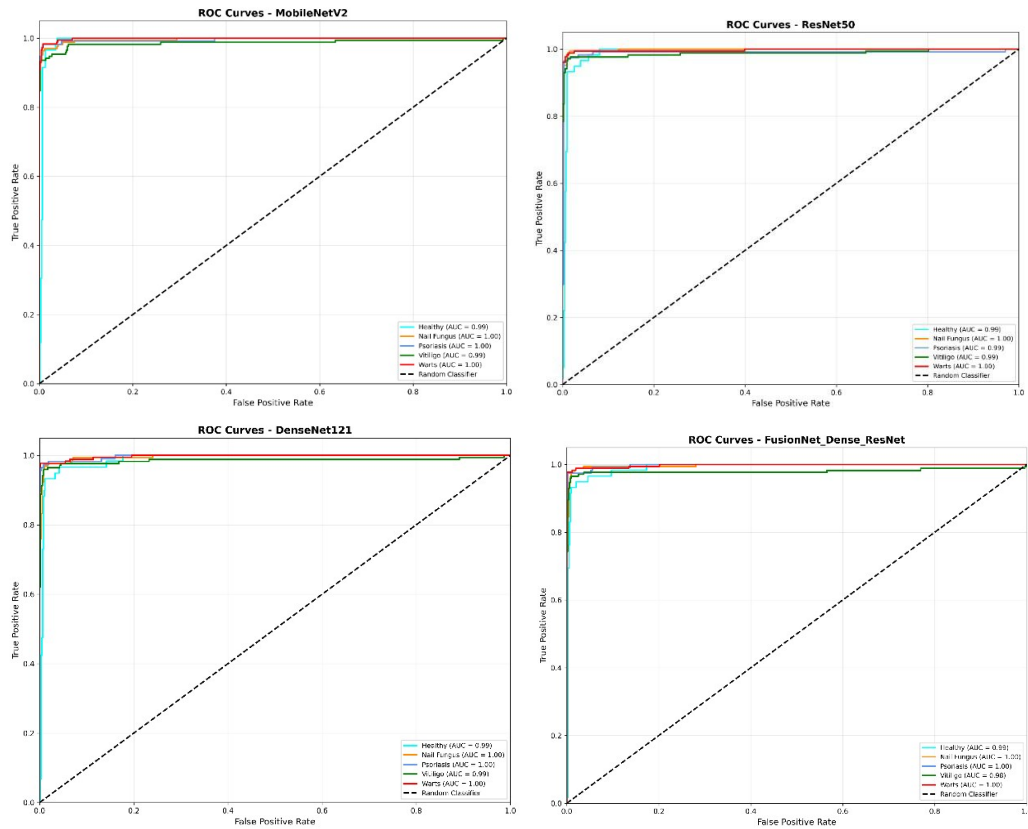
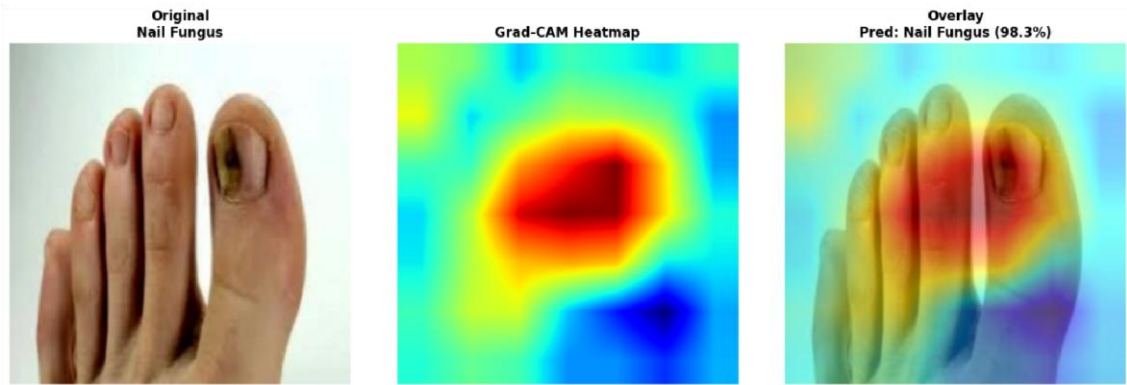

Figure 11: ROC curves of different models

Extensive ROC-AUC analysis confirmed that, all the models used in this study are highly effective classifiers with strong discriminate power. The pre-trained networks, especially VGG16, MobileNetV2, and ResNet50, performed very well with perfect AUC scores (1.00) for specific classes. Both the Custom_CNN and DenseNet121 models also performed near perfect with all but one of the classes getting AUCs of 0.98 or 0.99, respectively. This consistent level of quality performance confirms the high sensitivity and specificity of all models.

4.7 Visualization of Model Attention with Grad-CAM

Gradient-Weighted Class Activation Mapping (Grad-CAM) are effective methods for visualization and interpretation of deep-learning models' attention to regions of interest (ROI) in images []. These methods make it possible to visualize which parts located in the images enormously affected the model's prediction. These techniques also improve the model's interpretability by offering clarity on what the model learns, and it becomes easier for clinicians to understand and trust diagnosis predictions.



In this work, Grad_CAM has been applied to the proposed hybrid model (FusionNet_Dense_ResNet).

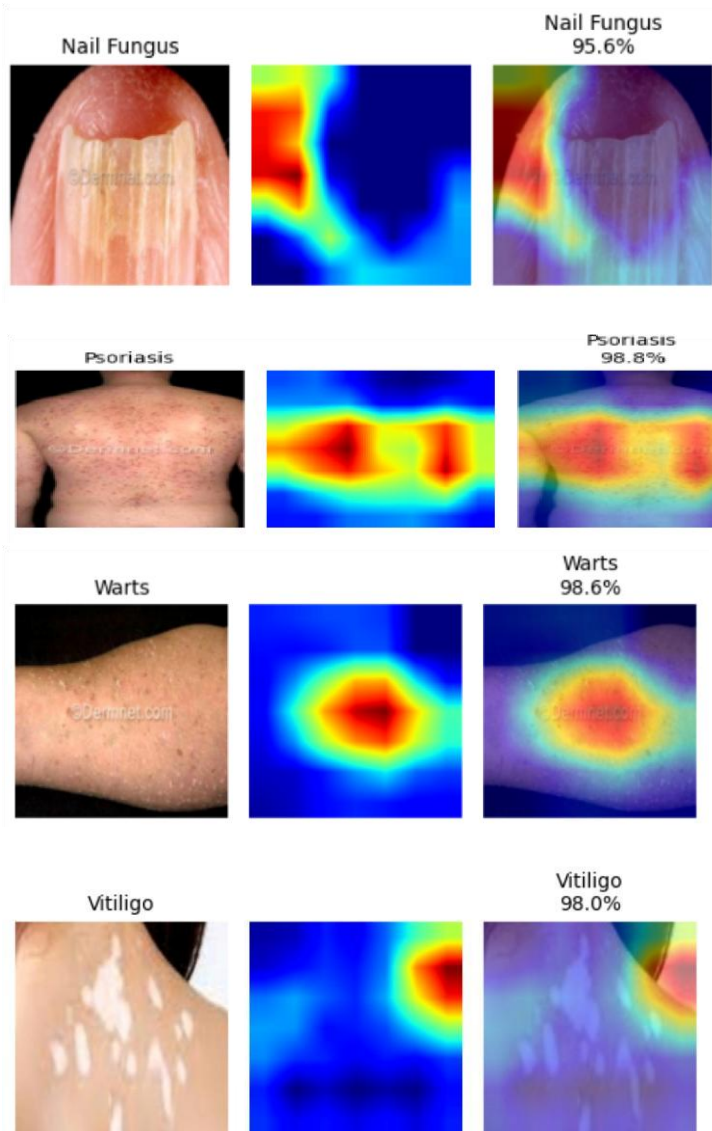

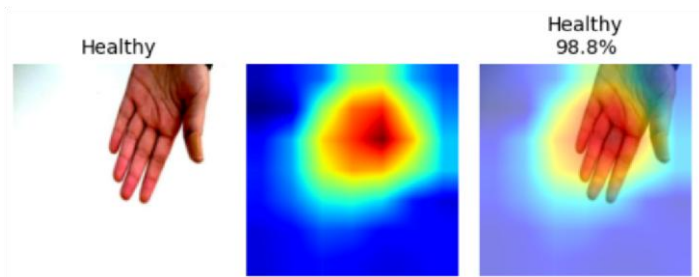
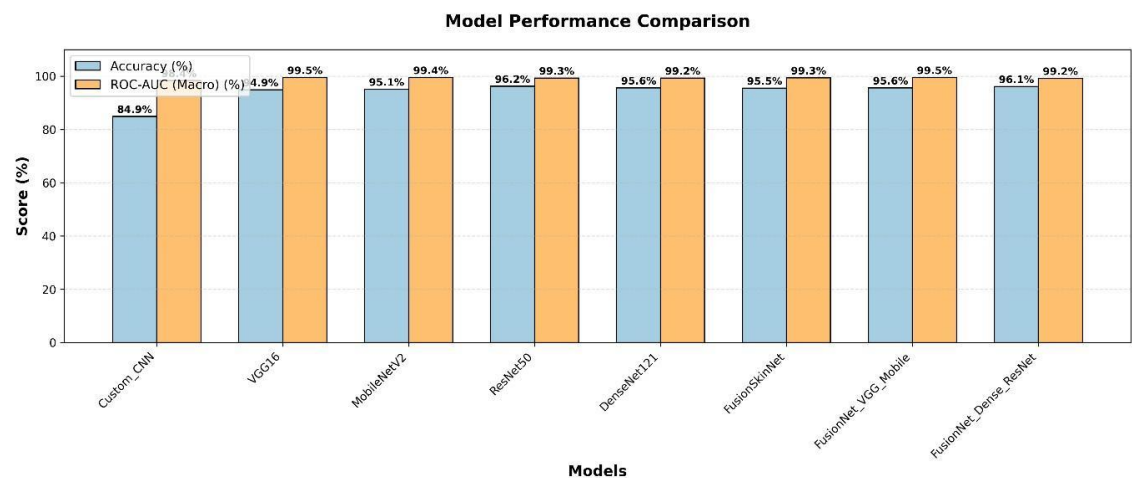

Figure 12: Output of Grad_Cam in FusionNet Model

4.8 Discussion



A comparative analysis of the six models confirmed that deep learning models are very powerful in terms of multi-class dermatological disease classification, where an evident performance ranking could be discerned. The superior architecture is the FusionNet model that reached best overall performance with 96.36% accuracy, 94.60% precision, 96.02% recall and a 95.22% F1-score. This was validated by a macro ROC-AUC of 0.9925. This improved performance demonstrates that the combination of DenseNet and ResNet feature extractors holds strong combinations for learning richer, holistic representations. In general, this enables our model to learn highly discriminative features, while it does not significantly distort the trade-off between precision and recall. Of particular interest is FusionNet's high recall, highlighting its ability to be sensitive in detecting cases of positive disease, which is an important consideration for clinical diagnostic use (due to the cost associated with false negatives).

The pre-trained architectures in its stand-alone form also achieved a competitive performance. ResNet50 (96.07% accuracy) and DenseNet121 (95.63% accuracy) demonstrated a strong and stable performance in all evaluation matrices indicating the superiority of deep residual connections and dense block in learning complex dermatological texture patterns. Both models showed high ROC-AUC scores (0.9928 and 0.9921), which also implies a good class separation capabilities of the model. Meanwhile, MobileNetV2 (95.05%) and VGG16 (94.91%) achieved slightly lower accuracies. Nonetheless, these models achieved high ROC-AUC levels (0.9944 and 0.9952), indicating the fact that even these lightweight and legacy architectures possess substantial discriminative capacity. Their high recall indicates they are also robust proposals which can be used as potential solutions for the resource limited or mobile health environments.

Conversely, the Custom_CNN showed a big disparity when comparing with its competitors, presenting lower accuracy (84.86%) and precision, recall and F1-measure scores than all other tested models. Such a performance gap reflects the fundamental bottleneck of learning with shallow, hand-crafted architecture

compared with deep, pre-trained networks which can "inherit" large-scale prior knowledge via transfer learning. The lower ROC-AUC 0.9837 that we observed suggests weaker class separation of the model, a weakness that is particularly evident in the context of a challenging dataset where diseases can look similar visually or have subtle textural differences.

In conclusion, it is strongly established that deeper networks and specifically fused hybrid networks provide significant gains for complex dermatological classification. The success of FusionNet up on Resnet50 and Densenet121 networks indicates that the multi-level feature extraction does work effectively. These results highlight the importance of (1) deep feature hierarchies, and (2) DL techniques such as transfer learning and architectural fusion to train an end-to-end model capable of achieving clinically acceptable diagnostic performance.

CHAPTER 5

CONCLUSION

5.1 Findings & Contributions

The main contributions of this study provide significant progress for Explainable AI; an automated diagnosis system with macroscopic skin images. Across all experiments, the most significant contribution was the creation of a very strong hybrid deep learning architecture-FusionNet_Dense_ResNet-achieving state-of-the-art accuracy 96.36% and macro ROC-AUC 0.9925 under five clinically relevant skin conditions (healthy skin, vitiligo, psoriasis, nail fungus and warts). This result indicates the model's good capability to discriminate small inter-class differences even under difficult real-world images in which lesions have different colors, shapes, lights and texture.

An important contribution of this thesis is the proposal of Explainable AI through Grad-CAM for the on FusionNet only. The Grad-CAM images could identify distinctive lesion areas that impacted model predictions including the depigmented patches in vitiligo, scaly plaques in psoriasis and hyperkeratotic textures in warts. This interpretability promotes clinical trust, and most importantly it means that the predictions arise directly from clinically relevant dermatological cues. These patient-centric interpretations support the usability for dermatologists and non-dermatologists, making AI-based diagnosis interpretable and clinically actionable.

Additionally, the class-wise statistical analysis (sensitivity, specificity, precision and F1-score) helped to gain insights for model performance with lesions of different types. FusionNet was close to a near-perfect (100%) precision and specificity with warts, and it has shown high performance for nail fungus (97.02%), vitiligo (98.18%). These results support the generalisability of the model to visually heterogeneous disease categories.

In general, the contributions of this study are not limited to the classification accuracy. By integrating a fusion based deep learning network with explainable AI, this thesis offers a clinically-aligned interpretable and effective solution which improves confidence, increases diagnostic transparency and aids in deployment of deployable AI-assisted dermatology

systems—especially useful for telemedicine applications and healthcare facilities with limited resources.

5.2 Future Scope

This network-deep learning for classification of skin diseases, to be said has a big future. Firstly, it would be possible to further develop the diagnostic use of our model by incorporating recognition of additional skin diseases such as impetigo, rosacea or measles [acne, eczema]. In the future, this data set can be extended to cover more range of skin tone as well as a wide variety of lighting condition and lesion types. The custom CNN with attention mechanism can further be investigated to improve the accuracy of multiclass classification.

For secondary risk prediction, future models could incorporate multimodal data—such as patient history, symptoms, or structured clinical notes—to produce more holistic diagnostic outcomes resembling real clinical workflows.

For secondary risk prediction, multi-modal information, such as patient history, symptoms or structured clinical notes may be considered in future models so that it can generate more holistic diagnostic results which are closer to true clinical workflows. Last but not least, such an implementation could enable real-time diagnosis on mobile or edge devices in teledermatology scenarios and especially in regions with tight resources where dermatologists are rare. Creation of a user-friendly clinical interface, addition with feedback loops from dermatologists, and implementation within prospective clinical validation studies remain as crucial future steps to take this work forward toward a reliable AI tool for patients in health care systems.

5.3 Conclusion

The potential value of the implementation of deep learning on solutions to skin disease is huge and there is a incomparable advantage in alleviating redundant work for dermatologists and decreasing pressure on medical resources. This paper introduces a Hybrid deep framework for common inflammatory and infectious skin diseases, channeled with the power of DenseNet121 and ResNet50 as backbone also it consist explainable AI in balancing high-accuracy and interpretability [attention enhanced cnn].

This research also adds to the novelty in building a Custom CNN with an attention block, however it performs lower than hybrid model fusion of DenseNet121 and ResNet50 84.86% vs. 96.36%. Custom CNN made valuable contributions to the research. This shed the light on how dermatological patterns are complex and showed that deeper, pre-trained networks are crucial for a generalized feature extraction. Although modest in performance, our custom model supported the role of attention mechanisms to emphasize disease-relevant visual cues. A comprehensive class-wise performance assessment, confusion matrices, ROC curves and error analysis further enhanced our understanding of the behaviour of the models.

Despite its success, the research is still on a secondary vulnerabilities and skin tones and it requires lighting changes as well as testing in real clinical workflows. The model can be validated using different datasets and therefore applied to a wider range of domains. In particular, explainable hybrid feature fusion enables accurate and transparent diagnosis of common skin diseases. These findings provide a solid ground for the development of AI-based dermatology tools to aid in early diagnosis, offload clinical workload and access to care across underserved areas.

REFERENCES

- [1] Hammad, M., Pawiak, P., ElAffendi, M., Abd El-Latif, A. A., & Abdel Latif, A. A. (2023). Enhanced deep learning approach for accurate eczema and psoriasis skin detection. *Sensors*, 23, Article 7295, pp. 1–17. <https://doi.org/10.3390/s23167295>
- [2] Ahmad, N., Shah, J. H., Khan, M. A., Baili, J., Ansari, G. J., Tariq, U., Kim, Y. J., & Cha, J.-H. (2023). A novel framework of multiclass skin lesion recognition from dermoscopic images using deep learning and explainable AI. *Frontiers in Oncology*, 13, Article 1151257, pp. 1–17. <https://doi.org/10.3389/fonc.2023.1151257>
- [3] Mousa, A., Safwat, A., Elgohr, A. T., Elhadidy, M. S., Abdelfatah, R. I., & Kasem, H. M. (2025). Attention-enhanced CNNs and transformers for accurate monkeypox and skin disease detection. *Scientific Reports*, 15, Article 32924, pp. 1–30. <https://doi.org/10.1038/s41598-025-12216-y>
- [4] Pardhi, S., Mude, A., Anvhane, V., Sahare, A., & Dhone, M. (2025). Automated detection of acne, eczema, and vitiligo: Deep learning approach to skin disease classification. *ResearchGate*, April 2025, pp. 1–12. <https://doi.org/10.13140/RG.2.2.30758.23369>
- [5] Deepa, J., & Madhavan, P. (2025). An advanced skin lesion segmentation and classification framework using deep learning strategies. *Scientific Reports*, 15, Article 33926, pp. 1–37. <https://doi.org/10.1038/s41598-025-08255-0>
- [6] Liu, H., Dou, Y., Wang, K., Zou, Y., Sen, G., Liu, X., & Li, H. (2025). A skin disease classification model using multi scale combined efficient channel attention module. *Scientific Reports*, 15, Article 6116, pp. 1–19. <https://doi.org/10.1038/s41598-025-90418-0>
- [7] Low, M., & Raina, P. (2019). Automating vitiligo skin lesion segmentation using convolutional neural networks. *arXiv Preprint*, arXiv:1912.08350, pp. 1–8. <https://arxiv.org/abs/1912.08350>
- [8] Alam, M. N., Munia, T. T. K., Tavakolian, K., Vasefi, F., MacKinnon, N., & Fazel-Rezai, R. (2016). Automatic detection and severity measurement of eczema using image processing. *Proceedings of the Annual International Conference of the IEEE Engineering in Medicine and Biology Society (EMBC)*, 2016, pp. 1365–1368. <https://doi.org/10.1109/EMBC.2016.7590889>
- [9] Velasco, J. S., Catipon, J. V., Monilar, E. G., Amon, V. M., Virrey, G. C., & Tolentino, L. K. S. (2023). Classification of skin disease using transfer learning in convolutional neural networks. *International Journal of Emerging Technology and Advanced Engineering*, 13(4), 1–9. https://doi.org/10.46338/ijetae0423_01
- [10] Thomsen, K., Christensen, A. L., Iversen, L., Lomholt, H. B., & Winther, O. (2020). Deep learning for diagnostic binary classification of multiple-lesion skin diseases. *Frontiers in Medicine*, 7, Article 574329, pp. 1–9. <https://doi.org/10.3389/fmed.2020.574329>
- [11] Mulani, A. O., Birajadar, G., Ivkovic, N., Salah, B., & Darlis, A. R. (2023). Deep learning based detection of dermatological diseases using convolutional neural networks

- and decision trees. *Traitement du Signal*, 40(6), 2819–2825.
<https://doi.org/10.18280/ts.400642>
- [12] Groh, M., Harris, C., Soenksen, L., Lau, F., Han, R., Kim, A., Koochek, A., & Badri, O. (2021). Evaluating deep neural networks trained on clinical images in dermatology with the Fitzpatrick 17k dataset. *arXiv Preprint*, arXiv:2104.09957, pp. 1–17.
<https://arxiv.org/abs/2104.09957>
- [13] Shah, S. A. H., Shah, S. T. H., Khaled, R., Buccoliero, A., Shah, S. B. H., Di Terlizzi, A., Di Benedetto, G., & Deriu, M. A. (2024). Explainable AI-based skin cancer detection using CNN, particle swarm optimization and machine learning. *Journal of Imaging*, 10(12), Article 332, pp. 1–24. <https://doi.org/10.3390/jimaging10120332>
- [14] Malik, S. G., Jamil, S. S., Aziz, A., Ullah, S., Ullah, I., & Abohashrh, M. (2024). High-precision skin disease diagnosis through deep learning on dermoscopic images. *Bioengineering*, 11, Article 867, pp. 1–24. <https://doi.org/10.3390/bioengineering11090867>
- [15] Sharma, S., Bhadula, S., Juyal, P., & Kulshrestha, C. (2020). Machine learning algorithms based skin disease detection. *International Journal of Innovative Technology and Exploring Engineering*, 9(2), 4044–4049.
<https://doi.org/10.35940/ijitee.B7686.129219>
- [16] Abbas, S., Ahmed, F., Khan, W. A., Ahmad, M., Khan, M. A., & Ghazal, T. M. (2025). Intelligent skin disease prediction system using transfer learning and explainable artificial intelligence. *Scientific Reports*, 15, Article 1746, pp. 1–17.
<https://doi.org/10.1038/s41598-024-83966-4>
- [17] Zhang, B., Zhou, X., Luo, Y., Zhang, H., Yang, H., Ma, J., & Ma, L. (2021). Opportunities and challenges: Classification of skin disease based on deep learning. *Chinese Journal of Mechanical Engineering*, 34, Article 112, pp. 1–14.
<https://doi.org/10.1186/s10033-021-00640-8>
- [18] Mahmood, A., Afrin, S., Mridha, M. F., Safran, M., Alfarhood, S., & Che, D. (2025). Vitiligo diagnosis with ResNet and SwinNet: Explainable deep learning for skin lesion analysis. *Scientific Reports*, 15, Article 24533, pp. 1–20. <https://doi.org/10.1038/s41598-025-09938-4>
- [19] Khan, H., Yadav, A., Santiago, R., & Chaudhari, S. (2023). Melanoma detection using deep learning-based classifications. *Sensors*, 23, Article 3313, pp. 1–16.
<https://doi.org/10.3390/s23041783>
- [20] Kasem, H. M., Elgohr, A. T., Elhadidy, M. S., Abdelfatah, R. I., & Safwat, A. (2025). Vitiligo detection using coordinate attention and explainable deep learning. *Scientific Reports*, 15, Article 32924, pp. 1–28. <https://doi.org/10.1038/s41598-025-12216-y>
- [21] Mahmood, A., Afrin, S., Mridha, M. F., Safran, M., Alfarhood, S., & Che, D. (2025). XAI for melanoma using dermoscopic image data: Explainable deep learning for clinical support. *Scientific Reports*, 15, Article 24533, pp. 1–21.
<https://doi.org/10.1038/s41598-025-0993>

ORIGINALITY REPORT

20%	16%	14%	12%
SIMILARITY INDEX	INTERNET SOURCES	PUBLICATIONS	STUDENT PAPERS

PRIMARY SOURCES

1	Submitted to Daffodil International University Student Paper	3%
2	www.mdpi.com Internet Source	2%
3	dspace.daffodilvarsity.edu.bd:8080 Internet Source	1%
4	Submitted to Midlands State University Student Paper	1%
5	Submitted to Malayan Colleges Mindanao, A Mapua School Student Paper	<1%
6	Submitted to University of Bolton Student Paper	<1%
7	Submitted to University of Hull Student Paper	<1%
8	Submitted to University of Westminster Student Paper	<1%
9	Submitted to Bournemouth University Student Paper	<1%
10	research.usq.edu.au Internet Source	<1%
11	umpir.ump.edu.my Internet Source	<1%

12	Internet Source	<1 %
13	www.iieta.org Internet Source	<1 %
14	Pushpa Choudhary, Sambit Satpathy, Arvind Dagur, Dharendra Kumar Shukla. "Recent Trends in Intelligent Computing and Communication", CRC Press, 2025 Publication	<1 %
15	Submitted to University of Ulster Student Paper	<1 %
16	backend.orbit.dtu.dk Internet Source	<1 %
17	Submitted to De Montfort University Student Paper	<1 %
18	pmc.ncbi.nlm.nih.gov Internet Source	<1 %
19	Submitted to Manipal International University Student Paper	<1 %
20	www.nature.com Internet Source	<1 %
21	Submitted to Benazir Bhutto Shaheed University, Lyari Student Paper	<1 %
22	Submitted to Liberty University Student Paper	<1 %
23	hdl.handle.net Internet Source	<1 %
24	jurnal.polgan.ac.id Internet Source	<1 %

25	Submitted to SASTRA University Student Paper	<1 %
26	Submitted to University of Keele Student Paper	<1 %
27	Submitted to Symbiosis International University Student Paper	<1 %
28	"Advances in Artificial Intelligence and Machine Learning in Big Data Processing", Springer Science and Business Media LLC, 2025 Publication	<1 %
29	Submitted to University of Sydney Student Paper	<1 %
30	bmcoralhealth.biomedcentral.com Internet Source	<1 %
31	ebin.pub Internet Source	<1 %
32	"Smart Data Intelligence", Springer Science and Business Media LLC, 2026 Publication	<1 %
33	Kapsis, Dimitrios. "Applications for E- Government : Global Terrorism Analysis", University of Piraeus (Greece), 2024 Publication	<1 %
34	Submitted to islamicuniversity Student Paper	<1 %
35	"Advances in Data-Driven Computing and Intelligent Systems", Springer Science and Business Media LLC, 2024 Publication	<1 %

36	www.coursehero.com Internet Source	<1 %
37	Sushil Kamboj, Pardeep Singh Tiwana. "Innovations in Computing", CRC Press, 2025 Publication	<1 %
38	Mohammad Shojaeinia, Azamossadat Hosseini, Mostafa Naderi, Bardia Baloutch et al. "A comprehensive overview: deep learning approaches to central serous chorioretinopathy diagnosis", BMC Ophthalmology, 2025 Publication	<1 %
39	peerj.com Internet Source	<1 %
40	www.researchsquare.com Internet Source	<1 %
41	Submitted to University of Hertfordshire Student Paper	<1 %
42	Zhefei Cai, Yingle Fan, Tao Fang, Wei Wu. "VSGNet: visual saliency guided network for skin lesion segmentation", Expert Systems with Applications, 2025 Publication	<1 %
43	openbioinformaticsjournal.com Internet Source	<1 %
44	Mohamed S. Elhadidy, Abdelrahman T. Elgohr, Ahmed Mousa, Ahmed Safwat, Roayat Ismail Abdelfatah, Hossam M Kasem. "Benchmarking Pre-trained CNNs and Vision Transformers for Mpox-related Dermatological Image Classification on MSLD v2.0", Results in Engineering, 2025	<1 %

45 Shankar Babu, Mahesh Babu Kota. "Synergies in Smart and Virtual Systems using computational intelligence", CRC Press, 2025

Publication

<1 %

46 Submitted to University of Technology, Sydney

Student Paper

<1 %

47 doaj.org

Internet Source

<1 %

48 ijireeice.com

Internet Source

<1 %

49 Submitted to Universiti Teknologi Malaysia

Student Paper

<1 %

50 Submitted to Adtalem Global Education

Student Paper

<1 %

51 Paolo Neri, Michela Fiaschi, Giovanni Menchini. "Semi-Automatic Tool for Vitiligo Detection and Analysis", Journal of Imaging, 2020

Publication

<1 %

52 link.springer.com

Internet Source

<1 %

53 Zahra Raeisi, Shayan Rokhva, Fatemeh Rahmani, Ali Goodarzi, Hossein Najafzadeh. "Multi-label diagnosis of dental conditions from panoramic x-rays using attention-enhanced deep learning", Oral and Maxillofacial Surgery, 2025

Publication

<1 %

54 acikbilim.yok.gov.tr

Internet Source

<1 %

55 Boddu, Sindhu. "Energy-Efficient Object Detection for Aerial Imagery: Quantization and Deployment of YOLOv4-Tiny on Raspberry Pi", The University of North Carolina at Charlotte

Publication

<1 %

56 bmcmedinformdecismak.biomedcentral.com

Internet Source

<1 %

57 pdffox.com

Internet Source

<1 %

58 pt.scribd.com

Internet Source

<1 %

59 www.springerprofessional.de

Internet Source

<1 %

60 Ahmed Mousa, Ahmed Safwat, Abdelrahman T. Elgohr, Mohamed S. Elhadidy, Roayat Ismail Abdelfatah, Hossam M. Kasem. "Attention-Enhanced CNNs and transformers for accurate monkeypox and skin disease detection", Scientific Reports, 2025

Publication

<1 %

61 Submitted to Coventry University

Student Paper

<1 %

62 J. Deepa, P. Madhavan. "An advanced skin lesion segmentation and classification framework using deep learning strategies", Scientific Reports, 2025

Publication

<1 %

63 uhra.herts.ac.uk

Internet Source

<1 %

64 www.frontiersin.org

Internet Source

<1 %

65	www.jetir.org Internet Source	<1 %
66	"Computational Intelligence and Healthcare Informatics", Wiley, 2021 Publication	<1 %
67	123dok.com Internet Source	<1 %
68	Graziela Sória Virgens, João Alfredo Teodoro, Emmanuel Iarussi, Tiago Rodrigues, Danilo Trabuco Amaral. "Enhancing and advancements in deep learning for melanoma detection: A comprehensive review", Computers in Biology and Medicine, 2025 Publication	<1 %
69	V. Shibina, T. M. Thasleema. "A hybrid approach to detecting Parkinson's disease using spectrogram and deep learning CNN-LSTM network", International Journal of Speech Technology, 2024 Publication	<1 %
70	cdn.techscience.cn Internet Source	<1 %
71	www.efri.uniri.hr Internet Source	<1 %
72	www.grafiati.com Internet Source	<1 %
73	Danilo Avola, Irene Cannistraci, Marco Cascio, Luigi Cinque et al. "MV-MS-FETE: Multi-view multi-scale feature extractor and transformer encoder for stenosis recognition in echocardiograms", Computer Methods and Programs in Biomedicine, 2024	<1 %

74

Deepam Goyal, Ankit Sharma, Mohamad Abou Houran. "Intelligent Machinery Fault Diagnostics and Prognostics - The Future of Smart Manufacturing", CRC Press, 2025

Publication

<1 %

75

P.V. Mohanan. "Artificial Intelligence and Biological Sciences", CRC Press, 2025

Publication

<1 %

76

Sajjan Singh, Sarabpreet Kaur. "Latest Trends in Engineering and Technology - AICTE Sponsored 2nd International Conference on 13th - 14th July, 2023", CRC Press, 2024

Publication

<1 %

77

Tasneem Ahmed, Shrish Bajpai, Mohammad Faisal, Suman Lata Tripathi. "Advances in Science, Engineering and Technology: A Path to the Future - Proceedings of the International Conference on Advances in Science, Engineering and Technology (ICASET - 2024), Organized by Department of Computer Application, Integral University, Lucknow, India", CRC Press, 2025

Publication

<1 %

78

Wang Yuqi, Seung-Jae Lee, Dong-Bin Shin, Ah-Rim Lee, Jun-Gi Byun, Chi Hong Lim, Kwan Ho Bae, Seung-Hwan Oh. "Vegetation characteristics and assessment of habitat suitability for *Pedicularis ishidoyana* Koidz. & Ohwi (Scrophulariaceae) community", Journal of Asia-Pacific Biodiversity, 2023

Publication

<1 %

79

ijarsct.co.in
Internet Source

<1 %

80 inria.hal.science <1 %
Internet Source

81 theses.hal.science <1 %
Internet Source

82 D. Lakshmi, Ravi Shekhar Tiwari, Rajesh Kumar Dhanaraj, Seifedine Kadry. "Explainable AI (XAI) for Sustainable Development - Trends and Applications", CRC Press, 2024 <1 %
Publication

83 "Proceedings of the 11th International Conference on Robotics, Vision, Signal Processing and Power Applications", Springer Science and Business Media LLC, 2022 <1 %
Publication

84 Bruno Oliveira, Helena R. Torres, Pedro Morais, Fernando Veloso, António L. Baptista, Jaime C. Fonseca, João L. Vilaça. "A multi-task convolutional neural network for classification and segmentation of chronic venous disorders", Scientific Reports, 2023 <1 %
Publication

85 Catur Supriyanto, Abu Salam, Junta Zeniarja, Danang Wahyu Utomo et al. "A Bibliometric Review of Deep Learning Approaches in Skin Cancer Research", Computation, 2025 <1 %
Publication

86 Dothang Truong. "Demystifying AI - Data Science and Machine Learning Using IBM SPSS Modeler", CRC Press, 2025 <1 %
Publication

87 Krishna Veni Paluri, Garima Nain, Ashish Gupta. "Advancements in acne detection and classification: A bibliometric analysis", Computers and Electrical Engineering, 2025
Publication <1%

88 Md Abdullah All Mahmud, Sadia Afrin, M. F. Mridha, Sultan Alfarhood, Dunren Che, Mejdil Safran. "Explainable deep learning approaches for high precision early melanoma detection using dermoscopic images", Scientific Reports, 2025
Publication <1%

89 Md. Kamrul Hasan, Md. Asif Ahamad, Choon Hwai Yap, Guang Yang. "A survey, review, and future trends of skin lesion segmentation and classification", Computers in Biology and Medicine, 2023
Publication <1%

90 Sagheer Abbas, Fahad Ahmed, Wasim Ahmad Khan, Munir Ahmad, Muhammad Adnan Khan, Taher M. Ghazal. "Intelligent skin disease prediction system using transfer learning and explainable artificial intelligence", Scientific Reports, 2025
Publication <1%

Exclude quotes Off

Exclude matches Off

Exclude bibliography Off