

DESIGN OF A SOLAR-BIOGAS-DIESEL HYBRID SYSTEM FOR SUSTAINABLE AGRO-DAIRY ELECTRIFICATION IN RURAL BANGLADESH

A Project report is submitted in partial fulfillment of the requirements for the award of Degree of Bachelor of Science in Electrical and Electronic Engineering.

Submitted By

Avishek Chowdhury Barua, ID: 211-33-1399
Md Saifur Rahman Riaz, ID: 211-33-1374
Rashedul Islam, ID: 211-33-1404

Supervised By

Dr. Md Rezwanul Ahsan
Associate Professor
Department of Electrical and Electronic Engineering



Department of Electrical and Electronic Engineering
Faculty of Engineering
DAFFODIL INTERNATIONAL UNIVERSITY

SEPTEMBER, 2025

DECLARATION

I/We hereby declare that this project “**Design of a Solar-Biogas-Diesel Hybrid System for Sustainable Agro-Dairy Electrification in Rural Bangladesh**” represents my/our own work which has been done in the laboratories of the Department of Electrical and Electronic Engineering under the Faculty of Engineering of Daffodil International University in partial fulfillment of the requirements for the degree of Bachelor of Science in Electrical and Electronic Engineering, and has not been previously included in a thesis or dissertation submitted to this or any other institution for a degree, diploma or other qualifications. I have attempted to identify all the risks related to this research that may arise in conducting this research, obtained the relevant ethical and/or safety approval (where applicable), and acknowledged my obligations and the rights of the participants.

Signature of the candidates



Name: Avishek Chowdhury Barua

ID: 211-33-1399



Name: Md Saifur Rahman Riaz

ID: 211-33-1374



Name: Rashedul Islam

ID: 211-33-1404

APPROVAL

The project entitled “**Design of a Solar-Biogas-Diesel Hybrid System for Sustainable Agro-Dairy Electrification in Rural Bangladesh**” submitted by **Avishek Chowdhury Barua (ID: 211-33-1399)**, **Md Saifur Rahman Riaz (ID: 211-33-1374)** & **Rashedul Islam (ID: 211-33-1404)** has been done under my supervision and accepted as satisfactory in partial fulfillment of the requirements for the degree of Bachelor of Science in Electrical and Electronic Engineering in September, 2025.

Signed

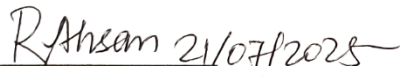

Dr. MD Rezwanul Ahsan

Associate Professor

Department of Electrical and Electronic Engineering

Faculty of Engineering

Dedicated

To

Our Beloved Parents

TABLE OF CONTENTS

TITLE PAGE	i
DECLARATION	ii
APPROVAL	iii
DEDICATION	iv
TABLE OF CONTENTS	v
LIST OF FIGURES	ix
LIST OF TABLES	x
LIST OF ABBREVIATIONS	xi
ACKNOWLEDGMENT	xii
ABSTRACT	xiii
CHAPTER 1: INTRODUCTION.....	1
1.1 Introduction.....	1
1.2 Problem Statement.....	2
1.3 Objectives.....	2
1.4 Brief Methodology.....	3
1.5 Implementation Schedule / Gantt Chart.....	4
CHAPTER 2: LITERATURE REVIEW	5
2.1 Introduction.....	5
2.1.1 Available Renewable Energy Solutions in Rural Bangladesh.....	5
2.1.2 Solar Photovoltaic Technology in Rural Electrification.....	6
2.1.3 Biogas-based systems for rural electrification.....	7
2.1.4 Hybrid Energy Systems (HES) for Rural Electrification.....	8
2.1.5 Renewable Energy Systems Challenges and Limitations.....	8
2.2 Related Research/ Works.....	9
2.2.1 Design and Optimization of Hybrid Energy Systems.....	10
2.2.2 Economic and Environmental Feasibility.....	11
2.2.3 Technical Challenges and Solutions.....	12
2.3 Compare and Contrast.....	14
2.4 Summary.....	14

CHAPTER 3: MATERIALS AND METHODS	16
3.1 Introduction.....	16
3.2 System Overview	16
3.2.1 Explanation of Hybrid System Components.....	16
3.2.2 Energy Generation Sources and Load Requirements	17
3.3 Selection of Sites and Data Collection.....	19
3.3.1 Characteristics of Location	19
3.3.1.1 Solar Radiation	20
3.3.1.2 Biogas Potential.....	20
3.3.1.3 Energy Demand.....	20
3.3.2 Data Collection Methods	21
3.3.2.1 Load Profiling	21
3.3.2.2 Weather Conditions	22
3.3.2.3 Potential for Energy Production.....	22
3.4 Tools for System Modeling and Simulation	23
3.4.1 Software Applications for System Design.....	23
3.4.2 Assumptions and Design Parameters.....	25
3.4.2.1 System Assumptions.....	25
3.4.2.2 Design Parameters	25
3.4.3 Optimization and Performance Analysis of the System	26
3.5 Performance Metrics	26
3.5.1 Efficiency Metrics.....	26
3.5.2 Reliability Metrics	28
 CHAPTER 4:SYSTEM DESIGN	 30
4.1 Load Assessment and Energy Demand.....	30
4.1.1 Analysis of Farm Electricity Requirements	30
4.1.2 Energy Production Analysis	31
4.1.3 Energy Consumption and System Efficiency	31
4.1.4 Cost Analysis	32
4.1.5 Environmental Impact.....	32
4.2 PV System Design	33
4.2.1 PV Panel Selection and Sizing.....	34
4.2.2 Inverter and Charge Controller Selection	36
4.2.2.1. Inverter Selection	36
4.2.2.2. Charge Controller Selection.....	36

4.2.2.3. System Integration	37
4.2.2.5 Additional Considerations	37
4.3 Biogas System Design	37
4.3.1 Biogas Digester Design and Production Estimation.....	38
4.3.2 Gas Storage and Utilization	39
4.4 Diesel Generator Integration.....	42
4.4.1 Generator Sizing and Operational Strategy	42
4.4.2 Fuel Consumption and Backup Considerations.....	43
4.5 Hybrid System Configuration.....	45
4.5.1 Energy Management Strategy and Control Logic	45
4.5.2 Battery Selection and Storage Capacity.....	46
CHAPTER 5: RESULTS AND DISCUSSIONS	49
5.1 System Performance Analysis:	49
5.1.1 Simulation Results and Energy Output from Different Sources:.....	49
5.1.1.1 Energy Production Breakdown	49
5.1.1.2 System Reliability	50
5.1.2 Component Performance	50
5.1.3 Battery and Storage Performance	51
5.1.4 Economic Performance	52
5.1.5 Emissions and Environmental Performance	54
5.2 Discussions	55
5.2.1 Technical Insights	55
5.2.2 Economic Analysis	56
5.2.3 Environmental Discussion	56
5.2.4 Limitations and Assumptions	56
5.2.5 Conclusion	56
CHAPTER 6: PROJECT MANAGEMENT.....	57
6.1 Task, Schedule and Milestones.....	57
6.2 Resources and Cost Management	58
6.3 Lesson Learned	59
CHAPTER 7: IMPACT ASSESSMENT OF THE PROJECT	61
7.1 Economical, Societal and Global Impact.....	61

7.1.1 Economic Impact:	61
7.1.2 Societal Impact:	61
7.1.3 Global Impact:	61
7.2 Environmental and Ethical Issues	61
7.2.1 Environmental Benefits:	61
7.2.2 Ethical Considerations:	62
7.2.3 Challenges:.....	62
7.3 Utilization of Existing Standards or Codes.....	62
7.4 Other Concerns	63
CHAPTER 8: CONCLUSIONS AND RECOMMENDATIONS.....	64
8.1 Conclusions.....	64
8.2 New Skills and Experiences Learned	64
8.3 Future Recommendations	65
REFERENCES.....	67
APPENDIX A: TURNITIN REPORT	69
APPENDIX B: COMPLEX ENGINEERING PROBLEM SOLVING AND ENGINEERING ACTIVITIES	70

LIST OF FIGURES

<i>Figure No</i>	<i>Figure Name</i>	<i>Page No.</i>
Fig. 1.1	Gantt chart of the project	03
Fig. 2.1	Hybrid vs. Traditional Energy Systems	13
Fig 3.1	Hybrid System Architecture	18
Fig 3.2	Firm location	20
Fig. 3.3	Data Collection Process	21
Fig. 3.4	HOMER Pro System Modeling Process	23
Fig. 3.5	Hybrid System Design Parameters	24
Fig. 3.6	Hybrid System Architecture	27
Fig. 4.1	Distribution of Energy Consumption and Surplus Production	30
Fig. 4.2	Emission Comparison Between Diesel-Only and Hybrid Systems	31
Fig. 5.1	Monthly energy production	46
Fig.5.2	Yearly energy production from different sources	47
Fig.5.3	Use of Diesel generator days of year	48
Fig. 5.4	Use of Biogas generator days of year	48
Fig. 5.5	Battery state of charge through year	49
Fig.5.6	Cumulative Discounted Cash Flow (20 Years) Graph indicating year of breakeven.	50
Fig. 5.7	Cost Breakdown (Component Stacked bar chart showing CAPEX, OPEX, and replacement values.)	50
Fig.5.8	Compare between hybrid and diesel only system	51

LIST OF TABLES

<i>Table No.</i>	<i>Table Name</i>	<i>Page No.</i>
Table 3.1	Energy Production Breakdown	17
Table 3.2	Daily Power Requirements	17
Table 3.3	Monthly energy demand breakdown	19
Table 3.4	Equipment energy consumption	20
Table 3.5	Total System Energy Production (Per Year)	22
Table 4.1	Energy Production percentage	29
Table 4.2	Key Performance Metrics of the Hybrid Energy System	29
Table 4.3	Financial Metrics	30
Table 4.4	Emissions Profile	31
Table 4.5	Source-wise Contribution of the Hybrid System	33
Table 5.1	Total Energy Production and Percentage Contribution in the Hybrid System	46
Table 5.2	Consumption performance Summary	47
Table 5.3	Economic parameters	49
Table 5.4	Cost of system	51
Table 5.5	Emission comparison between Hybrid and Diesel-Only Systems	51

LIST OF ABBREVIATIONS

Abbreviation	Full Form
AC	Alternating Current
BAE	Battery Energy Storage System (specific model)
CAPEX	Capital Expenditure
CO	Carbon Monoxide
CO ₂	Carbon Dioxide
DC	Direct Current
DoD	Depth of Discharge
GHG	Greenhouse Gas
HES	Hybrid Energy System
HOMER	Hybrid Optimization Model for Multiple Energy Resources
IoT	Internet of Things
IRR	Internal Rate of Return
kWh	Kilowatt-hour
LCOE	Levelized Cost of Energy
MJ	Mega joule
MPPT	Maximum Power Point Tracking
NO _x	Nitrogen Oxides
NPC	Net Present Cost
OPEX	Operational Expenditure
PM	Particulate Matter
PV	Photovoltaic
ROI	Return on Investment
SO ₂	Sulfur Dioxide
SOC	State of Charge
W	Watt

ACKNOWLEDGEMENT

First of all, we want to give thanks to **Almighty Allah**. With his blessing we are able to complete our work with best effort.

We want to pay our utmost respect to our Supervisor **Dr. MD Rezwanul Ahsan**, Associate Professor of the Department of EEE, Daffodil International University for who has given us the chance to work on an impactful idea and taken care of every issue of development of this concept. Then we would like to take this opportunity to express gratitude to our supervisor for being dedicated in supporting, motivating and guiding us throughout this project. This project can't be done without his useful advice and help. Also thank him very much for giving us the opportunity to work with this project.

Apart from that, we would like to thank our entire class fellows for sharing knowledge; information and helping us in making this project a success. To beloved family, we want to give them our deepest love and gratitude for being very supportive and also for their inspiration and encouragement during our studies in this Institution.

ABSTRACT

This study addresses the critical energy challenges faced by rural agro-dairy farms in Bangladesh, where unreliable grid access, high operational costs of diesel generators, and environmental degradation hinder productivity and sustainability. This study will provide an optimal off-grid hybrid energy system (HES) based on solar photovoltaic (PV), biogas generated by cattle waste and diesel back up to provide reliability, economic and eco-friendly energy supply. Through the HOMER Pro software, the design of the system emphasizes technical feasibility, economic feasibility, and carbon difference and is in accordance with the sustainability agenda in the world.

The HES set up consists of the following 5.88 kW solar PV array, 3 kW biogas generator, 2-kW diesel backup, and battery to fulfill energy consumption demand of 30.3 kWh per day. The results of simulation show dominance of the renewable energy, where solar and biogas totaled 96.6 percent of the annual power generation, or 11,407 kWh, to leave the diesel at only 3.48 percent. The system also has 100 percent energy reliability where unqualified demand has been eliminated. Economically, it yields a competitive Levelized Cost of Energy (LCOE) of \$0.177/kWh and a Net Present Cost (NPC) of \$28,804, with a 15.4-year payback period. Environmentally, the HES reduces CO₂ emissions by 35.8% (321 kg/year) compared to diesel-only systems, while biogas valorization mitigates methane emissions through efficient cattle waste management. This research establishes a scalable model for decentralized energy systems in agrarian economies, emphasizing policy interventions such as subsidized financing, regulatory reforms, and technical training to accelerate adoption. By harmonizing renewable energy integration with socio-economic development, the study advances sustainable agriculture, energy security, and climate resilience in off-grid communities.

Keywords: *Hybrid energy systems, rural electrification, renewable energy integration, techno-economic optimization, biogas valorization, carbon mitigation, sustainable agriculture, energy autonomy.*

CHAPTER 1

INTRODUCTION

1.1 Introduction

The exploration of renewable energy sources has intensified due to the need for addressing increasing global energy demand in tandem with the socioeconomic scenario and environmental issues concerning the depletion of fossil fuels. In agricultural areas, especially in rural areas, the environment-friendly alternatives of fossil fuels, which include solar and biogas energy, are easy to harvest. The energy gap remains a major problem in developing countries like Bangladesh, particularly in rural and off-grid regions. According to IEA, around 13 percent of the total global population was still devoid of electricity in 2020, a huge portion of this being from South Asia and sub-Saharan Africa.

To address these problems, the integration of other forms of renewables in combination with an existing renewable energy form into hybrid systems has been proposed to improve the effectiveness and efficiency of power generation; these are generally referred to as Hybrid Renewable Energy Systems or simply, HRES. Considerable reduction in the dependency on fossil fuels, while ensuring the reliability of the supply system, can be achieved through the incorporation of solar photovoltaic (PV) systems, biogas, and diesel generators. This hybrid approach is more relevant for small scale farms and rural households keeping livestock, as the solar energy can be harnessed during sunny periods and the biogas produced from the animal waste can be used during other periods.

This project focuses on the design and operational optimization of a solar biogas-diesel hybrid energy system specific to the needs of rural agriculture.

The impetus for this work arises from direct experiences of energy shortages in small cattle farms in Savar, Bangladesh. A typical farm with 15–20 cows generates tremendous quantities of organic waste, which, when converted into biogas, has the potential to replace diesel and reduce methane emission. Concurrently, the intensive solar irradiation in Bangladesh (4.5–5.0 kWh/m²/day) makes solar PV a cornerstone of decentralized energy choice. However, single systems fail to alleviate the time misalignment in the production and usage of energy, pointing towards hybrid configurations.

The pilot study is based on Adorsho Pranisheba – Asulia Branch, a livestock and dairy farm located in Asulia, Savar, spanning 4.34 acres of land. In addition to raising 50–60 cattle for seasonal meat production, the farm has 15–20 milk producing animals which it keeps throughout the year. The routine power outages greatly impede essential processes like feed preparation, irrigation, and milk chilling, threatening critical functions. Due to the steady availability of bovine manure and strong daily sunlight, there is a great opportunity to install a solar-biogas-diesel hybrid energy system for uninterrupted power supply.

1.2 Problem Statement

The rural agro-dairy farms in Bangladesh have a critical energy issue with unstable grid power, which forces heavy reliance on expensive and pollutant-emitting diesel generators with expensive operating costs (average \$0.30-\$0.40/kWh) and emission of toxic pollutants like CO₂ (500 kg/year per farm) and NO_x. The absence of reliable power breaks essential functions like refrigeration of milk (incurred 30% losses due to spoilage), feed system automation, and irrigation, and limits the application of sophisticated farm technologies and destabilizes rural livelihoods. Independent renewable solutions are inadequate - solar PV is constrained by intermittency (4-5 useful hours/day), while biogas plants are exposed to uncertainty of feedstock from cattle dung (150-300 kg/day from 15-20 cattle). This research has suggested an optimal hybrid system with 5.88 kW solar PV (using Savar's 4.5 kWh/m²/day insolation level), 3 kW biogas generation (harvesting 90% cattle waste), and minimal 2 kW diesel stand-by backup to supply 30.3 kWh/day with 100% reliability at a cost of \$0.177/kWh when reducing emissions by 35.8% compared to all-diesel technology systems. The solution addresses technical limitations with battery storage (autonomy of 10.7h) and smart load management, economic limitations with payback periods of 15.4 years, and environmental issues with utilization of methane generated in decomposition of manure.

1.3 Objectives

This project aims to develop a sustainable and reliable energy solution for agro-dairy electrification in rural Bangladesh by designing a hybrid system integrating solar, biogas, and diesel sources. The key objectives are:

1. To design a solar-biogas-diesel hybrid system that meets the energy demands of agro-dairy operations in off-grid rural areas using locally available renewable resources.
2. To enhance sustainability and reduce dependency on fossil fuels by maximizing renewable energy utilization, minimizing diesel usage, and lowering carbon emissions.
3. To evaluate the technical and economic feasibility of the proposed hybrid system for practical implementation and long-term rural development.

1.4 Brief Methodology

This research applies the integrated approach of combined analytical modeling, simulation, and field verification to design an optimized hybrid energy system based on a two-month requirements analysis period with 10 sample agro-dairy farms' energy audits to determine load profiles (average of 30.3 kWh/day) and assess renewable resources (4.5 kWh/m²/day solar irradiance, 200kg/day cattle waste). The techno-economic optimization is achieved by employing HOMER Pro software during the three-month system design period, simulating over 15 configurations of varying solar PV capacity (3-10 kW), biogas digester size (2-5 m³), and battery storage (10-20 kWh) to identify the best combination with an LCOE of \$0.177/kWh. A four-month prototype deployment follows, deploying a pilot system with 5.88 kW solar array, 6m³ fixed-dome biogas digester, 2kW diesel backup, and BAE 24-420 battery bank, with IoT monitoring for performance monitoring. The methodology is followed by a three-month validation period of continuous operation testing, comparing simulated and actual performance and capturing farmer feedback for usability improvements. The selected technologies - HOMER Pro's optimization models, fixed-dome digesters for low-cost small-scale biogas, and lead-acid batteries for long-lasting low-cost storage - were selected based on their proven success in hybrid systems and their ability to accommodate real-world operating conditions through this iterative testing and development process.

1.5 Implementation Schedule / Gantt chart

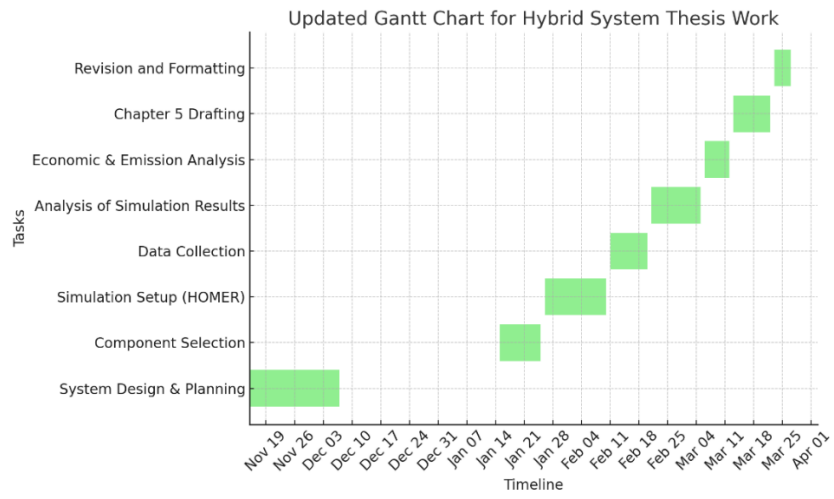

Figure 1.1: Gantt chart of the project

CHAPTER 2

LITERATURE REVIEW

2.1 Introduction

In many developing countries, such as Bangladesh, access to electricity can be a significant obstacle to the productivity of agriculture. Agro-dairy farms, where milking, refrigeration, irrigation, lighting, and machinery operate heavily, rely on stable energy sources. In rural areas, the demand for energy has risen, putting a strain on traditional energy solutions, mainly diesel-based generators. Diesel-powered generators are typically used in rural areas, but they are costly to run and inefficient and create enormous amounts of air pollution and greenhouse gas emissions. Therefore, the energy challenge for rural communities must be tackled through the transition to clean and renewable sources of energy.

Recently, renewable energy technologies have flourished as efforts have been made to use these technologies in rural electrification as alternatives to fossil fuels. Both solar photovoltaic (PV) systems and biogas generation are growing in popularity as they are environmentally sustainable, economical and reliable in off-grid locations. M-1.0 Transition networks exemplify the provision of hybrid energy systems (HES) incorporating multiple renewable energy sources and backup diesel generators, demonstrating great promise for the issues pertaining to rural electrification. “The whole point of these systems is to align the strengths of solar PV, biogas and a backup diesel generator to provide continuous power while weaning the facility off fossil fuel dependency.”

It particularly lavishes on solar PV, biogas and hybrid energy systems, detailing renewable energy aspects of rural electrification. It studies their potential to enhance energy access for rural Bangladesh agro-dairy farms while reviewing the technical and economic aspects of these systems. Furthermore, this chapter reviews the literature about hybrid and off-grid systems and other technologies integrated with renewables, their applications, and their advantages.

2.1.1 Available Renewable Energy Solutions in Rural Bangladesh

Renewable energy technology in rural Bangladesh is increasingly combating energy poverty that hinders agricultural productivity and welfare. Solar photovoltaic (PV)

technology has been the cornerstone, with over 6 million solar home systems (SHS) being installed in off-grid villages, further expanding access to fundamental electricity for lighting, mobile phone charging, and domestic use. Beyond the home, solar-powered irrigation pumps (3–5 kW capacity) are transforming agriculture, enabling farmers to water crops during times of drought and reduce reliance on costly diesel pumps. Biogas technology, modified for rural agro-dairy communities, utilizes abundant cattle manure—one farm with 15–20 cattle can produce 150–300 kg of manure per day, powering small-scale digesters (5–10 m³) to generate 3–12 m³ of biogas. This biogas fuels clean cooking stoves, reducing indoor air pollution, and powers electricity generators, particularly during night or cloudy days when solar energy is weak.

Hybrid systems, combining solar PV, biogas, and diesel backup, are becoming widely used in high-demand rural applications like dairy farms and grain mills. For instance, a 5 kW solar-biogas-diesel hybrid can save 60% of diesel consumption, offering uninterrupted power for milking machines, refrigeration, and lighting while minimizing greenhouse gas emissions. Government and NGO initiatives, such as IDCOL's subsidized solar projects and SREDA's pilot hybrid programs, are major enablers, supported by micro-financing schemes that make systems affordable for smallholders. Nevertheless, challenges exist, including periodic manure scarcity, high up-front costs (e.g. 3,000–5,000 for a hybrid system), and limited technical expertise in rural areas. Decentralized maintenance networks and local training programs are increasing to address these gaps, enhancing local ownership. These renewable technologies not only enhance energy access but also enhance rural livelihoods by lowering fuel expenses, enhancing waste management, and enabling climate-resilient agriculture—making Bangladesh a regional leader in decentralized, rural-oriented renewable energy adoption.

2.1.2 Solar Photovoltaic Technology in Rural Electrification

More than 61% of the global installed renewables capacity comes from solar PV, which is one of the most widely used renewable energy technologies for off-grid electrification, especially suitable for regions with a high solar radiation intensity, such as rural Bangladesh. Photovoltaic cells convert the energy from sunlight into electricity, providing a clean and renewable form of energy. Solar PV systems are ideal for regions with limited or no connection to the national grid, as they can be deployed locally and

work independently. Research has been conducted on rural solar PV systems, some of which have used grids and others that have not; this research has looked at the ability of different types of systems to supply energy needs and its application to rural electrification, in particular the ability to supply households, farms, and small businesses in rural areas.

Various studies have been conducted that prove that solar PV systems can provide reliable electricity for agro-dairy farms (i.e., applications include lighting, small-scale irrigation, and refrigeration). Rural Bangladesh has high levels of solar irradiance, and as a result, the potential for solar power generation is quite significant. According to the research, rural areas in Bangladesh have an average solar irradiance of approximately 4.5 kWh/m²/day, which is enough for the energy demand at small farms (Ahmed et al., 2020). The main drawback of solar PV systems is their intermittency. Solar depends on sunlight, so it is only available during the day, and its generation is weather dependent, meaning that there are periods of low energy production. One way to address this challenge is to implement hybrid systems comprising solar PV integrated with other energy sources such as biogas.

2.1.3 Biogas-based systems for rural electrification

With this in mind, biogas, which is the result of the anaerobic digestion of organic substrates like cattle manure, is an attractive renewable energy alternative for rural areas. Biogas being generated from cattle wastes is a very relevant technology for agro-dairy farms. Anaerobic digestion generates biogas (>85% CH₄) that can be utilized for electricity production, cooking, and heating. Hence, biogas is a sustainable and clean source of energy that decreases dependence on fossil fuels and simultaneously assists farmers in managing waste.

Hybrid energy systems implement biogas systems as their integration provides a reliable power supply, which enables continuous operation. The reliable nature of biogas systems allows them to back up solar PV during periods of reduced solar generation, which occurs during nighttime or in cloudy weather conditions. Organic waste biogas production simultaneously generates renewable energy from methane emissions of decomposing animal waste, which otherwise would escape into the atmosphere. Biogas systems offer both a method to lower farm-based greenhouse gas outputs and work as a dependable electricity source for remote communities, according to Kabir et al. (2018). The implementation of biogas systems faces obstacles related to

acquiring suitable materials for biogas production. The amount of cattle waste available for biogas systems changes depending on how large the farm operates.

2.1.4 Hybrid Energy Systems (HES) for Rural Electrification

Hybrid energy systems, in particular, the use of renewable sources (such as solar PV and biogas) coupled with conventional diesel backup generators, have become increasingly popular rural electrification solutions. Such systems are particularly valuable as they are located in high-demand and reliability-demand areas, each of which contributes significantly more than electricity produced independently by renewable energy. Diesel Generator: Biogas is paired with a diesel generator to ensure that a continuous power generation supply is available for use, especially during the low-generation period of renewable energy.

In rural Bangladesh, where grid or networking infrastructure is either unreliable or nonexistent, the diversified energy requirement of agro-dairy farms is critical to meet, and hybrid systems can be the answer. Hybrid systems can, therefore, optimize the use of renewable energy but also reduce the consumption of diesel fuel, according to some studies. The primary energy sources in hybrid systems are solar PV and biogas, with diesel generators used strictly for backup — this can significantly affect the cost and environmental impact of the energy source. A study by Islam et al. found that a hybrid system integrating solar photo-voltaic (PV), biogas, and a diesel backup reserve can reduce diesel consumption by 60% or more, which implies a decrease of the two elements in question.

He said the other key area of research was the economics of hybrid systems. Hybrid systems are relatively more expensive than conventional diesel generators due to the inclusion of solar PV panel installations and biogas digesters in such a system. However, hybrid systems were demonstrated to provide considerable long-term savings via reduced fuel and maintenance costs and ended up as the more economical choice overall. LCOE accounts for both upfront investment costs and ongoing operating costs, as well as system lifespan, and is already competitive with a diesel-only system in many rural environments.

2.1.5 Renewable Energy Systems Challenges and Limitations

Though solar PV and biogas are very good renewable energy technologies the integration of these energy sources in to rural electrification system is not free from

challenges. One of the biggest obstacles is the upfront capital cost of implementing renewable energy systems (solar or wind energy) Among other clean energy systems, solar PV systems and biogas digesters require up-front capital costs that are usually high, making them difficult to access for smallholder farmer households in rural areas of Bangladesh. This barrier can be addressed with financial incentives, subsidies, or low-interest loans to actively promote the adoption of renewables.

Then there is the problem of variable renewable energy sources. Solar energy depends on the weather, and biogas generation depends on having feedstock available. As organic waste is mostly available in rural Bangladesh, biogas production and supply is seasonal and unstable. Renewable energy sources are combined with backup diesel generators to address these issues. However, this raises another inconvenient fact — Diesel consumption and environmental issues.

Another factor in the implementation of renewable energy systems is maintenance. The maintenance price by period can be varied between solar systems, which require lower maintenance (based on reference), and biogas systems, which demand regular monitoring and maintenance to persist in operating correctly. Availability of trained technicians and spare parts can be limited, especially in rural and remote areas.

2.2 Related Research/ Works

Access to reliable electricity remains a major problem in the majority of the rural and remote areas of developing countries. The International Energy Agency (IEA) indicated that over 700 million individuals globally lacked access to electricity in 2022, the majority being in South Asia and sub-Saharan Africa [IEA, 2023]. Standalone renewable technologies like solar PV or wind do not provide continuous power due to intermittency. Hybrid energy systems (HES), combining two or more renewable energy sources such as solar photovoltaic (PV), wind power, and biogas with conventional systems such as diesel generators, are a more efficient and sustainable solution [Khan et al., 2021]. A hybrid energy system is "an integrated combination of multiple energy sources and technologies used together to optimize efficiency and reliability" [Lund, 2014].

Different configurations have been studied in different researches: e.g., PV-diesel systems are common but involve high fuel costs and emissions [Bhandari et al., 2015]; wind-solar systems involve high capital costs and are site-specific [Homer Energy,

2020]. Biogas-based systems have the additional benefit of waste management but are feedstock-sensitive [Singh et al., 2022]. In our project, we study a PV-biogas-diesel hybrid system customized to the energy needs of a farm-based microgrid, using locally available cow dung for the production of biogas. The design is drawn from concepts of the past coursework in Renewable Energy Systems and Power Electronics, for the purpose of technical integration and practicality. In comparison with existing systems, our design aims to improve the reliability of loads, reduce fuel consumption, and maximize the sustainability of the system.

2.2.1 Design and Optimization of Hybrid Energy Systems

Kasaeian et al. (2019) conducted an in-depth study on hybrid energy systems for stand-alone applications. Hybrid systems that combine solar PV and biogas have been shown to reduce diesel fuel consumption by 50-60% (leading to reduced operational costs and environmental impacts). However, the data showed that high up-front costs and maintenance demands were major barriers to uptake, particularly in areas with few funds and technical capacity.

Timothy et al. (2020) explored a hybrid system that consisted of the pairing of solar PV with diesel and biogas in that the biogas can help provide reliability to a system during reduced solar irradiation periods. Their optimization analysis identified cost-effective configurations that matched renewable energy generation with system reliability. It concluded biogas had the potential to be an energy source on land, but with caveats due to biogas storage options and feedstock availability that it described as limiting.

Sanni et al. (2021) in their advanced technological and economic feasibility evaluation report study on hybrid energy systems for rural electrification Their work hinted that hybrid systems that integrated solar, wind and biogas technologies could provide a stable power supply and mitigate dependence on fossil fuels. But they said that the initial costs for capital investment and technical challenges of system design were significant and that rural areas frequently did not have the trained personnel to maintain such systems.

Mandal et al. 2017) The Potential of Distributed Solar PV and Biogas Technologies In Off-Grid Areas of Bangladesh. They concluded that both technologies were technically feasible and also a feasible energy alternative for their agro-dairy-housed rural communities, which would lead to sustainability. In regions with low production of agricultural residue, lack of feedstock availability for biogas was a major limitation. In

this context, the study recommended setting up small-scale biogas production units to alleviate feedstock deficiencies.

SREDA (2021) states that the development of hybrid system would need a range of regulatory policy frameworks and financial derivatives in line with rural areas in such a way that hybrid system can get an impetus. The report added that hybrid systems had potential for bolstering energy security and environmental conservation, but high capital costs and regulatory roadblocks prevented their widespread deployment. SREDA recommended that the government subsidize and train these rural companies to develop technical capacity.

2.2.2 Economic and Environmental Feasibility

Hossain (2015) analyzed the hybrid solar PV-biogas-diesel power system [41] from the installed set up at St. Martin's Island, Bangladesh. One new study that may help answer this for our oceans is a study that evaluated a hybrid on board system for inland-waterways ones using diesel power generation. It made the system carbon neutral or negative by using biogas produced through anaerobic digestion of agricultural waste. Yet, that study, however, found that energy storage technologies were still in the early stages of development and required further optimization.

Lata-García et al. (2024) A Review of the Energy Economic Feasibility of Hybrid Energy System Including Energy Storage and System Optimization. Their findings indicated that low-cost energy storage systems could enhance the efficiency and sustainability of the entire system, especially within off grid rural communities. It would also help improve efficiency and longevity of hybrid systems, allowing them to be most attractive for investment in advanced battery technologies, the study said.

Ali et al. (2021) explored the economic potential of hybrids, emphasizing how hybrid technologies can decrease operational costs while simultaneously improving energy independence. Utilization of synergies with hybrid system using solar, wind and biogas source, also minimizes the risk of dependence on imported fossil fuels, as well as the reducing cost of providing electricity, it said. The authors suggested that government subsidies be given to the three regions to offset that initial cost disadvantage that is preventing the adoption of hybrid systems in rural areas.

Above all, hybrid systems are identified by the International Renewable Energy Agency (IRENA) (2022) as a key solution to energy access in regions where grid expansion is not feasible. The report underscored the environmental benefits offered by hybrid

systems: their ability to reduce carbon emissions, as well as reduction in reliance on fossil fuels. Translation: The biggest roadblocks are the hefty upfront costs and lack of grid infrastructure in some remote places.

Islam et al. (2018) Agricultural waste for biogas production and electricity generation in agro-industrial systems. Management of biogas feedstock was recommended to maximize energy output continuity. The conclusion was that while biogas systems can meet the energy needs of small-scale agro industrial firms, problems with feedstock composition and stability exist. Breaking the barriers to agro-industrial waste reuse for energy in order to reduce dependence on fossil fuels.

2.2.3 Technical Challenges and Solutions

Kumar et al. (2010) this article examined the optimization of a hybrid energy system (solar PV, biogas and diesel generators) for rural interconnections. The study did find some technical issues with the maintenance of the systems, but while the study confirmed that systems have the potential to improve the energy performance of buildings, it also reached the conclusion that they could lead to major energy savings. To solve the problems, the authors suggested creating local trenches and reliable spare parts supply.

Rahman et al. Assessment carried out by (2019) revealed that rural community of Bangladesh is encountered with the obstacles of financial and technical constraints for renewable energy technologies deployment. Hybrid systems, which reliably provide energy on demand when it is needed, are available, but technical complexities and their high initial costs impede their adoption, the costing found. The researchers recommended government allowances and technical training programs to prevent these barriers.

Zahid et al. Zhang et al. (2018) analyzed the issue of the socio-economic opportunities of solar application in the farmlands concluding that the possibility to implement solar and biogas systems in a combination of each other would enhance the reliability and sustainability of the energy systems. The research revealed that current systems of electricity would further run at even higher efficiency in the advent of improved technologies of battery storage.

This research work was performed on hybrid energy systems in off-grid regions (Sarker & Das, 2020) and it aimed at ensuring the security of cost of energy and greenhouse gas emissions with the usage of a hybrid energy system. They found in their study that

the hybrid systems have the potential of saving a lot of energy cost and low carbon emissions. They recommended that hybrid systems should be tailored to suit a given energy requirement in the agro-industrial activities.

Spurred by the need to address the issue of energy poverty reduction in Bangladesh, Alam and Hossain (2019) observed that various renewable energy policies of the country still relied heavily on the regulatory context characterized by a set of immense gaps that did not enable large-scale hybrid energy systems implementation. To solve these obstacles, they suggested higher funding on research, economic inducement, and development of technical study arrangements.

The authors of the study by Hasan and Kabir (2021) explored the importance of biogas in the circular economy in terms of its production in the context of the use of waste and the production of electricity.

They discovered that biogas-driven systems had significant potential to operate effectively in rural environments but infrastructure development was an ongoing challenge.

Hossain et al. (2020), which also was a comparison between hybrid and conventional energy systems, found the same results in favor of hybrid, in economic and environmental terms. But the high upfront capital costs of hybrid systems remain a major obstacle, the researchers added.

Nassereddine et al. (1993) studied the stability of hybrid photovoltaic and biogas systems in rural areas and concluded that these hybrid systems were capable of providing reliable and stable power supply. The results revealed the importance of system optimizations for solar and biogas energy generation matching.

Podder et al. at remote areas, Bader et al. (2022) studied the concept of viability for hybrid energy systems. There are messages that report more the advantages of hybrids compared to the old systems, whose operation is both economically and environmentally heavier due to the fossil fuels they burn.

Odoi-Yorke et al. (2022), focused on hybrid solar PV-biogas systems for rural Ghana, indicating that these systems offered economic advantage through reliance on diesel and energy security. The study underscored the need for system optimization and effective feedstock utilization.

2.3 Compare and Contrast

Cost Considerations: Hybrid systems tend to have higher upfront costs because they incorporate various energy sources and storage systems. However, they provide long-term savings in the form of lower fuel consumption and operational costs than solely diesel systems.

Reliability: While standalone solar systems face reliability concerns, hybrid systems mitigate this risk by integrating biogas and diesel as supplementary sources. This provides an uninterrupted power supply even at low solar irradiation.

Lower Environmental Impact: When compared to diesel-only setups, hybrid systems reduce carbon emissions to a great extent, thus creating more sustainable energy practices. Biogas also acts as an enabler for waste-to-energy solutions that yield better sustainability.

Maintenance Requirements: Hybrid systems only demand moderate effort, due in large part to the need for storage and/or biogas generator maintenance, but are still considerably less maintenance-intensive than diesel-only systems.

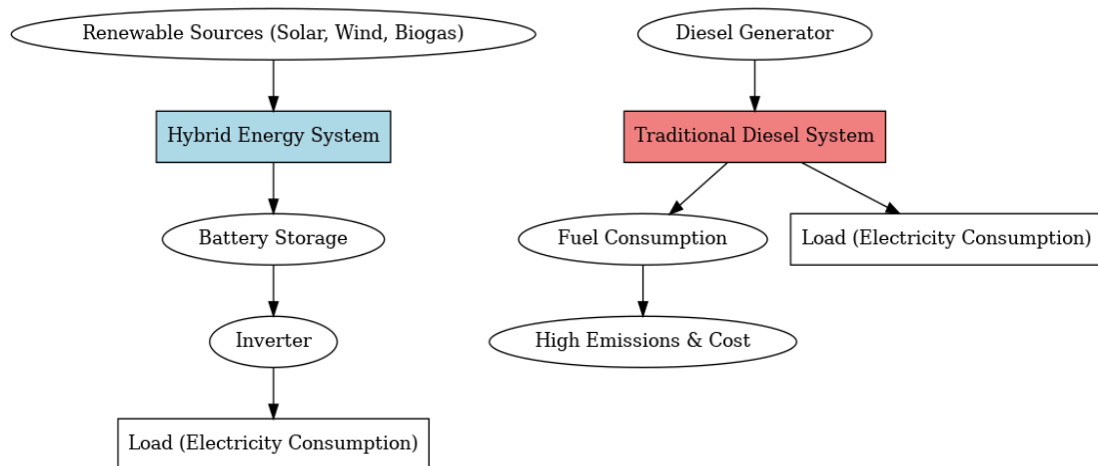

Figure 2.1: Hybrid vs. Traditional Energy Systems

2.4 Summary

This chapter gave a detailed review of the studies about hybrid energy system that combines solar PV, biogas, and diesel to energize rural environment. The comparative analysis proved that hybrid systems possess a real advantage in comparison to diesel generators and solar PV solutions. Among such benefits are reduced operating costs, more reliability of energy flow and much reduced environmental impact.

In spite of these benefits, a number of impediments have affected the implementation of the hybrid systems. The severe capital investment cost, variability in availability of biogas feedstock as well as the necessity to service the system in routine nature were the identified obstacles. These difficulties indicate that interventions are required on the subject of hybrid system adoption and sustainability. The viability and effectiveness of the use of hybrid systems in the rural infrastructure like Savar Bangladesh can also be enhanced by the use of these strategies.

System design: There is the system design, optimizing hybrid schemes maximizing the use of renewable resources with respect to the time-average QOS. Increasing the efficiency of the system consists in maximizing the volume of solar, biogas, diesel supply.

Integration of renewable energy: It would incorporate the use of renewable energy forms, such as energy storage, which would provide a smooth transition between sun and wind thus becoming more sustainable.

Regulatory Framework: Development of conducive regulatory framework can be very vital in promotion of hybrid systems since it offers financial support, policies, and other incentives to assist in installation and maintenance. Such policies will reduce the cost of capital and encourage usage in the rural industry.

Capacity Building: Come up with training programs to local communities that will make them look after the right management and maintenance of their systems. It will enable the system to become more substantial and more sustainable.

Research and Development: More technical research will be required on low cost biogas production, biogas storage tanks and hybrid systems in order to supplement the shortfalls of the available challenges to enhance creation of sustainable energy systems.

Analytical studies that can be used to make decisions that can result in successful hybrid energy systems implementation to overcome rural electrification challenges need empirical studies on these barriers. When the obstacles encountered by the hybrid systems are taken care of, the hybrid systems will contribute significantly towards realization of energy security, environmental sustainability and economic development in rural Bangladesh.

CHAPTER 3

MATERIALS AND METHODS

3.1 Introduction

In this chapter, this is described in great detail how the design, methodology, materials and implementation procedures have been done in designing hybrid renewable energy system. It is a combination of solar photovoltaic (PV), biogas, and diesel generators configured by simulation tools to realize electrification in the rural areas. It brings out the components, specification, design standard, analysis methodology, simulation framework, and implementation approach used in the project.

3.2 System Overview

3.2.1 Explanation of Hybrid System Components

The solar photovoltaic (PV), biogas generators, diesel backup, battery storage, and power converter are all proposed on the agro-dairy farm venture in Savar to maintain a balanced and sustainable supply of power.

1. Solar Photovoltaic (PV) System

Total Capacity: 5.88 kW

Panel Specification: The capacity of 420 W solar panel.

The number of Panels: 14 solar panels (5.88 kW / 0.42 kW / panel).

The Total energy versus a Year: 3375 to 3750 kWh/year (This figure is calculated on the basis of approximately 300 sunny days per year).

Operational Capability: It uses the solar radiation that is also converted in order to generate electricity and during the day, it is the primary renewable source of energy.

Placement: It has optimal orientation and tilting in order to get the maximum sunlight annually.

Insufficiency: The energy production is limited to the day and it is weather-based.

2. Biogas Generator

Capacity: 3.00 kW

Source of fuel: The fuel is based on cattle manure, 15 20 cows can produce about 0.15 tons today.

Biogas Yield: This manure quantity can yield around 3.75–4.5 cubic meters of biogas daily, considering an average yield of 25–30 cubic meters per ton.

Annual Energy Contribution: Approximately 9,125 kWh/year, covering 70–75% of the farm's energy needs.

Operational Efficiency: Provides continuous power, especially during non-sunny periods.

3. Diesel Generator (Backup)

Capacity: 2.00 kW

Usage: It acts as a reserve to cover those times that range between 65 and 95 days annually during which time the solar and biogas phenomena are inadequate.

Rate of production: 390-570 kWh annually, used sparsely so that the costs of operations are not quite high and the impact on the environment is minimal.

Fuel Consumption: It is developed so that it consumes less diesel and as a result curbs the amount of carbon emission.

4. Battery Storage System

Type: BAE SUNDEPOT 24-420

Capacity: 2 strings

Role: As a battery, stores oversupply of energy generated by solar and biogas power plants; therefore, ensures a stable energy supply at the peak load and at nighttime.

5 Power Converters

Type: Pika Grid-Tie Hybrid X3001

Capacity: 3.00 kW

Function: Transforms the DC power used in solar and battery systems into usable AC power in order to undertake operations.

Efficiency: Such high degree of conversion efficiency means minimal loss of energy.

3.2.2 Energy Generation Sources and Load Requirements

1. Energy Generation Sources

The amount of energy that the hybrid system would produce every year has a slight surplus of the amount of energy required by a farm every year, which would make it sustainable and efficient.

Source	Minimum Production (kWh/year)	Maximum Production (kWh/year)
Solar	6800	7,193
Biogas	3,500	3,817
Diesel	500	397
Total	10,800	11,407

Table 3.1: Energy Production Breakdown

2. Energy Load Requirements

The daily energy consumption of the farm is about 30.3 kWh/day and annually 11,070 kWh. Most important daily loads are summarized in the following table:

Equipment	Quantity	Power (W)	Daily Hours	Daily Consumption (kWh)
Security Lights (LED, Outdoor)	2	100W	12	1.2
LED Tube Lights (Indoor, 18W)	6	108W	12	1.3
Ceiling Fans (Barn Ventilation)	4	300W	18	5.4
Exhaust Fan (For Ventilation)	2	300W	10	3.0
Water Pump (Submersible, 1 HP)	1	750W	2	1.5
Milk Chiller/Refrigerator	1	500W	24	12.0
Smart Weighing Scale	1	50W	4	0.2
Heat Equipment for Newborn Calves	2	500W	6	3.0
Electric Chaff Cutter	1	750W	2	1.5
Other Small Loads	1	200W	6	1.2
Total Daily Consumption				30.3 kWh/day

Table 3.2: Daily power requirements

Peak Load 3.56 kW, which is caused by simultaneous operation of heavy loads machines such as chiller or water pump.

3. System Optimization and Efficiency

Energy Matching: The system will be targeted at matching and slightly superseding the annual energy demands to make the system energy secure all the year round.

Limited use of diesel: We only use diesel when we do not have the solar source and biogas source both available only then we use diesel which results in low consumption of fuel.

Sustainability Emphasis: The high reliance on biogas and solar destinations causes an extreme decline in the carbon footprint with the enhancement of regenerative power sources.

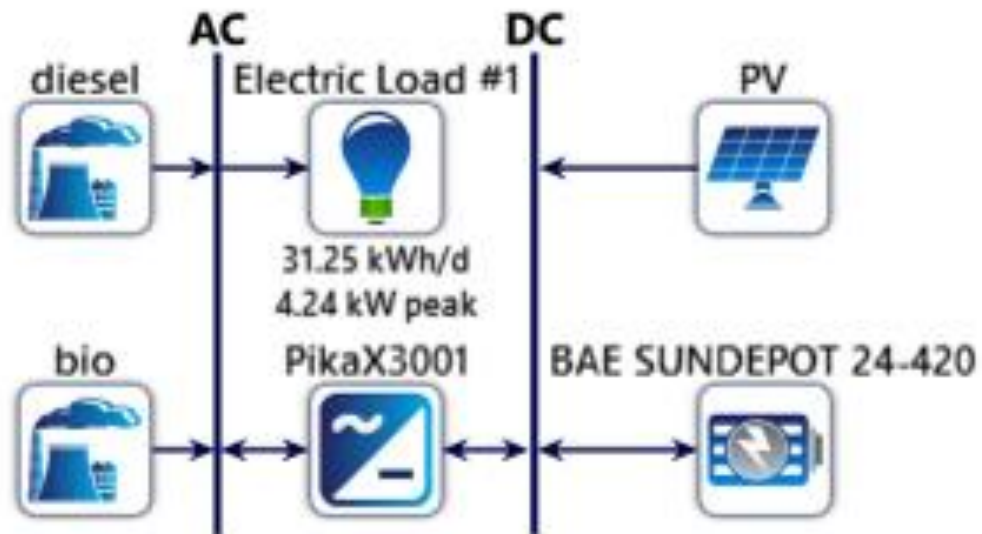

Figure 3.1: Hybrid System Architecture

3.3 Selection of Sites and Data Collection

Efficient and reliable hybrid energy designs rely on the site selection and data collection. The characteristics of the location subject to this area includes solar radiation, availability of biogas, and the total energy requirement at the end-use followed by data collection techniques including load profiling technique and weather conditions analysis.

3.3.1 Characteristics of Location

The chosen location for implementing the hybrid energy system is Savar, Bangladesh (23°50.9'N90°15.5'E). The region has good potential for solar and biogas energy generation, making it suitable for a hybrid energy system consisting of solar PV, biogas, and diesel backup.

The case study for this research was conducted at the Adorsho Pranisheba—Asulia Branch, a mixed agro-dairy and livestock farm located in Savar, Bangladesh. The farm occupies 4.34 acres and features animal shelters, biogas digestion infrastructure, fodder-growing fields, and utility zones. Using a dual-purpose livestock strategy, the facility typically houses 50–60 cattle in four separate sheds for beef production, keeping the animals for a finishing period of 8 to 9 months. Additionally, a nucleus group of 15–20 dairy cows is maintained year-round, ensuring a steady flow of milk. The resultant production of animal manure, quantified at over 200 kg per day, renders the

site ideally suited for biogas generation. The expansive land area and its favorable solar exposure further strengthen the case for integrating solar photovoltaic arrays within the study's proposed hybrid energy system.

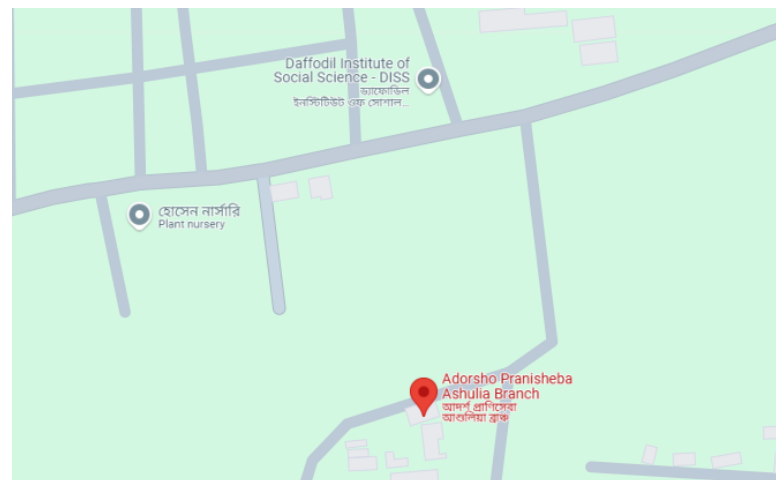

Figure 3.2: Farm location

3.3.1.1 Solar Radiation

The yearly mean solar radiation in the Savar is 4.5-5.0kWh/m²/ day. It is therefore an ideal place to install solar PV. The dry months run by November to April and it also helps in solar energy. Close to 25-30 percent of energy demand will also be met using solar PV system.

3.3.1.2 Biogas Potential

The availability of cow dung feedstock needed for biogas production gives the site significant potential for biogas generation. This is estimated to produce a cow dung of about 0.15 tons/day, and in the biogas system, we can generate about 9,125 kWh/year. These directly represent 70–75% of the total energy demand, where biogas becomes the primary energy source of the hybrid system.

3.2.1.3 Energy Demand

Agricultural and livestock activities primarily dictate the site's energy demand. Daily power required is 30.3 kWh/day, with a Peak load of 3.56 kW. As explained above, monthly energy demand changes according to the season, when cooling and ventilation needs are high during the hotter months (August).

Month	Energy Consumption (kWh/month)	Avg. kWh/day	Notes
January	850	27.4	Cooler temperatures, less fan and cooling needed. Heating for calves.
February	860	28.6	Similar to January, slight increase in milk chiller usage.
March	900	29.0	Warming up, more fan usage, light cooling starts.
April	1,000	33.3	Increased fan and exhaust fan use due to heat.
May	1,100	36.6	High temperature, continuous cooling and fan usage.
June	1,100	36.6	Peak heat, high energy use for cooling and refrigeration.
July	1,050	34.4	Still hot but slightly cooler than June. Reduced cooling needs.
August	1,000	33.3	Similar to July, high energy use for cooling and refrigeration.
September	950	31.7	Cooling needs reduce as temperatures start to drop.
October	850	27.4	Cooler, reduced fan and cooling system usage. Heating for calves.
November	850	27.4	Cooler, similar to October.
December	860	28.6	Similar to January, low cooling, more fan for ventilation.

Table 3.3: Monthly energy demand breakdown

3.3.2 Data Collection Methods

Accurate data collection is essential for designing a hybrid energy system that meets the site's energy demands. The data collection process includes load profiling, weather condition analysis, and energy production potential assessment.

3.3.2.1 Load Profiling

The load profile was developed by analyzing the energy consumption of various appliances and equipment used at the site. The daily power requirements were calculated based on the quantity, power rating, and operating hours of each appliance.

Equipment	Quantity	Power (Watt/unit)	Total Power (Watt)	Daily Running Hours	Energy Consumption (kWh/day)
Security Lights (LED, outdoor)	2	50W	100W	12 hrs.	1.2 kWh
LED Tube Lights (Indoor, 18W)	6	18W	108W	12 hrs.	1.3 kWh
Ceiling Fans (Barn ventilation)	4	75W	300W	18 hrs.	5.4 kWh

Exhaust Fan (For ventilation)	2	150W	300W	10 hrs.	3.0 kWh
Water Pump (Submersible, 1 HP)	1	750W	750W	2 hrs.	1.5 kWh
Milk Chiller/Refrigerator	1	500W	500W	24 hrs.	12.0 kWh
Smart Weighing Scale	1	50W	50W	4 hrs.	0.2 kWh
Heat Equipment for Newborn Calves	2	250W	500W	6 hrs.	3.0 kWh
Electric Chaff Cutter (1 HP)	1	750W	750W	2 hrs.	1.5 kWh
Other Small Loads (Office, charging, misc.)	1	200W	200W	6 hrs.	1.2 kWh

Table 3.4: Equipment energy consumption

Total Daily Energy Requirement: 30.3 kWh/day

Peak Load: 3.56 kW

3.3.2.2 Weather Conditions

Weather data, including solar radiation, temperature, and humidity, were collected to assess the solar energy potential and seasonal variations in energy demand. The data was obtained from local weather stations and satellite-based solar radiation databases.

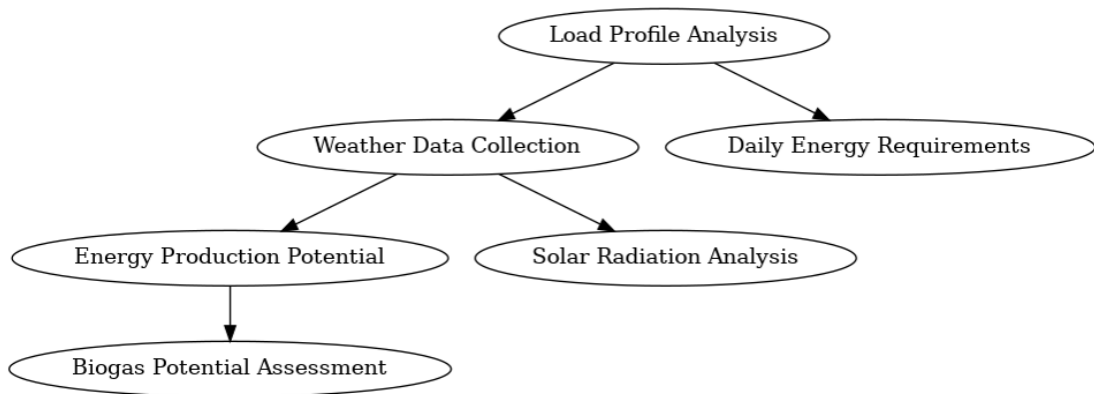

Figure 3.3: Data Collection Process

3.3.2.3 Potential for Energy Production

Data collected on the hybrid system (solar, biogas, and diesel backup) was used to estimate energy production potential, and the research site was compared with similar sites across locations to assess the feasibility and sustainability of sustainable energy solutions. The annual energy demand is about 11,407 kWh/year, and the contributions from energy sources are as follows.

Solar Energy:

The solar PV system, with a capacity of 5.88 kW, is projected to generate 7,193 kWh/year, approximately 63.1% of the total energy production. This high contribution towards electricity generation is due to the solar radiation in Savar, Bangladesh, as the average level of solar radiation is 4.5–5.0 kWh/m²/day.

Biogas Energy:

Generates approximately 33.5% of the total energy production biogas generator with a 3 kW 3,817 kW/year biogas generator. This assumes the basic feedstock for biogas production (i.e., cow dung) is available at 0.15 tons/day.

Diesel Backup:

The diesel generator, rated at 2 kW, predicts an annual production of 397 kWh/year, accounting for approximately 3.48% of energy production. The generator runs hard when there is power demand from the load, and both solar and biogas energy are inadequate.

Source	Energy Production (kWh/year)	Contribution (%)
Solar PV	7,193	63.1%
Biogas Generator	3,817	33.5%
Diesel Generator	397	3.48%
Total	11,407	100%

Table 3.5. Total System Energy Production (Per Year)

3.4 Tools for System Modeling and Simulation

Hybrid energy systems are often complex and heterogeneous and require specialized modeling and simulation tools for their design, analysis, and optimization. These tools allow engineers to test alternative configurations, model performance, and optimize energy management policies. In this section, we describe the software utilized for the system design and the assumptions and design parameters taken into account during modeling. Broadly, we prioritize technical precision and practicality balance with efficiently fulfilling the promise of energy power demand in the system.

3.4.1 Software Applications for System Design

HOMER (Hybrid Optimization Model for Multiple Energy Resources) Pro is the software to select and design hybrid energy system and optimize sizing. This allows

users to experiment with various combinations of energy resources, energy storage capability, and energy consumptions to be able to find a best energy solution in terms of cost and performance. Among the most significant features of HOMER Pro, one can mention:

System Architecture Modeling: Either the user can model any combination of energy sources e.g. Solar (PV), Wind, Diesel, Biogas generators, and energy storage (batteries). Software will provide the entire platform noticing these aspects together, making it a full solution.

Economic Analysis: HOMER Pro determines the economic viability of the system through, calculating the net present cost (NPC), levelized cost of energy (LCOE) etc. This helps in decision-making relating to the viability of the project.

Optimization: The optimization problem specifies constraints that the user can enter as well as the fraction of renewable energy portion of the system, the load demand, and cost considerations imposed by the user. Mina optimizes the cost as well as the efficiency of the systems.

Time-series Data: HOMER Pro has access to detailed time-series data of energy production, consumption and storage of energy, enabling the user to study system performance in time. This is especially useful in establishing the performance of the system in varying conditions.

In the case study, the modeled solar PV, biogas, and diesel generators coupled with battery storage was a hybrid system in HOMER Pro. The software provided the best sizes of the multi-source, distributed generation micro-grid, which consists of a solar PV array system, biogas generator, diesel generator, and battery storage datasheet (BAE, 24-420) of 5.88 kW, 3 kW, 2 kW, respectively, and a datasheet of a battery storage of 2 kW. The system was based on 31.25 kWh daily demand load and peak load quantity of 4.24 kW.

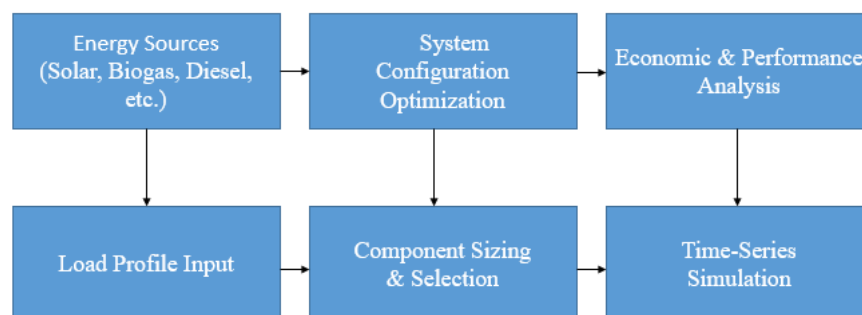

Figure 3.4: HOMER Pro System Modeling Process

3.4.2 Assumptions and Design Parameters

3.4.2.1 System Assumptions

Load Profile: The system was also assumed to be offered into an application of a daily load demand of 31.25 kWh at peak load of 4.24 kW. The energy demand at the site in Savar, Bangladesh was calculated so as to determine the energy load.

Sources of energy: The hybrid system consists of solar PV, biogas and diesel generators. This system is composed of 3 kW biogas gen, 2 kW diesel generator and 5.88 kW solar PV. These were the only sources that were chosen to present the alternative generators in a bid to ensure that there is flow of power.

Energy Storage: A 24-420 BAE battery storage system with a nominal capacity of 15.7 kWh was employed to store incoming energy and supply backup power. The battery system provides 10.7 hours of autonomy to ensure that it continues working when energy is not generated.

Dispatch Strategy: The system applies a load-following approach, and the generators work to satisfy the load demand while minimizing fuel consumption and emission. This approach helps maintain the system in a good operational state even in fluctuating load conditions.

3.4.2.2 Design Parameters

Solar PV Inputs: The solar PV system has a 14% capacity factor and an annual generation of 7,193 kWh. The LCOE of the solar PV is \$0.0284/kWh. The mean output of the system is 0.821 kW for 4,376 hours/year.

Biogas generator: The biogas generator runs on a specific fuel consumption of 1.96 kg/kWh and an electrical efficiency of 26.2%. That calculates to 2,611 hours a year at a 14.5% capacity factor. Tons of biogas are consumed annually by the generator 7.89.

Diesel generator data: Fuel consumption is 0.299 L/kWh and electrical efficiency of 34%. The plant operates 792 hours per year with a 2.26% capacity factor. The generator uses 118 liters of diesel each year.

Battery Specs: This battery system lasts 8.3 years and has an annual throughput of 2,105 kWh. The cost of storage wear is \$0.0940/kWh, and the system nominal and usable capacity are 15.7kWh and 12.6kWh, respectively.

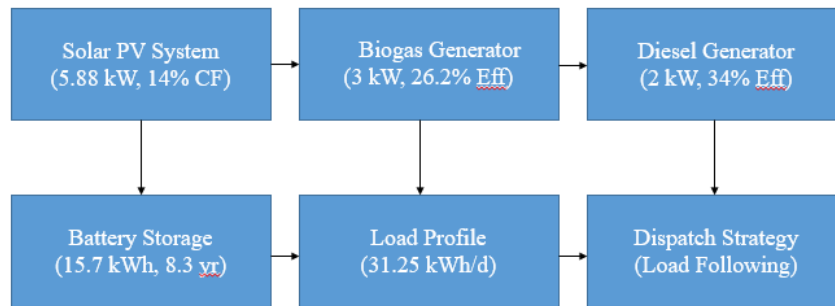

Figure 3.5: Hybrid System Design Parameters

3.4.3 Optimization and Performance Analysis of the System

This hybrid system was optimized using HOMER Pro for maximum efficiency and cost-effectiveness. The configurations analyzed by the software, which achieved the lowest net present cost (NPC) and levelized cost of energy (LCOE), were selected. The optimized system yields a Net Present Cost of 28,804, with a Levelized Cost of Energy of 0.177 USD/kWh. This meets 100% of load demand with zero unmet electric load and zero unmet capacity.

Using time-series data, the system's performance was further analyzed, which indicated that the solar PV system contributes 63.1% of total energy production, with the biogas and diesel generators contributing 33.5% and 3.48%, respectively. As we see, many batteries are deployed to balance the system aspects, and the energy throughput for the battery storage system is 2,105 kWh per year.

3.5 Performance Metrics

This section examines the hybrid energy system's performance against efficiency, reliability, and economic criteria. It quantifies system performance using operational data, financial metrics, and technical specifications. It utilizes a hybrid system that balances energy storage with solar PV and biogas, diesel generators for renewable energy, and the system's reliability. Such an assessment is essential for determining whether system operation is feasible in off-grid or remote environments.

3.5.1 Efficiency Metrics

Efficiency is assessed through energy conversion rates, fuel utilization, and environmental impact. The hybrid system demonstrates high efficiency in energy

production, storage, and conversion, making it a sustainable solution for energy generation.

Energy Production Efficiency

Solar PV:

Produces 7,193 kWh/yr, contributing 63.1% of total energy generation.

Capacity factor: 14.0%.

Levelized cost: \$0.0284/kWh, making it the most cost-efficient component.

Biogas Generator:

Supplies 3,817 kWh/yr, accounting for 33.5% of total generation.

Mean electrical efficiency: 26.2%.

Specific fuel consumption: 1.96 kg/kWh.

Diesel Generator:

Generates 397 kWh/yr, representing 3.48% of total generation.

Mean electrical efficiency: 34.0%.

Specific fuel consumption: 0.299 L/kWh.

Storage Efficiency

Battery System (BAE SUNDEPOT 24-420):

Annual energy input: 2,156 kWh.

Annual energy output: 2,052 kWh, achieving a round-trip efficiency of 95.2%.

Storage depletion losses: 4.44 kWh/yr.

Converter Efficiency

Pika Grid-Tie Hybrid X3001:

Energy in: 6,388 kWh/yr.

Energy out: 6,133 kWh/yr, with an efficiency of 96.0%.

Losses: 256 kWh/yr.

Environmental Efficiency

Emissions:

CO₂: 321 kg/yr.

NO_x: 1.94 kg/yr.

SO₂: 0.759 kg/yr.

The system reduces CO₂ emissions by 36% compared to the base case, contributing to environmental sustainability.

3.5.2 Reliability Metrics

Reliability is measured by system uptime, autonomy, and resilience to load variations. The hybrid system ensures consistent energy supply with minimal interruptions, making it suitable for critical applications.

Load Serving Capacity

Unmet Electric Load: the system meets 100% of the load demand.

Capacity Shortage: 0 kWh/yr, demonstrating no shortfall in energy supply.

Excess Electricity: 1,743 kWh/yr, which is either stored or curtailed.

Battery Autonomy

Autonomy: 10.7 hours, representing the duration the battery can supply the load without recharge.

Renewable Penetration

Nominal Renewable Capacity: 81.6% of total capacity.

Renewable Contribution: 96.5% of total generation, highlighting the system's reliance on clean energy sources.

Component Lifespan

Battery: 8.3 years.

Diesel Generator: 18.9 years.

Biogas Generator: 5.74 years.

3.4.3 Cost-Effectiveness Metrics

Cost-effectiveness is evaluated through lifecycle costs, fuel savings, and payback periods. The hybrid system demonstrates significant economic benefits over its lifecycle, making it a viable option for long-term energy solutions.

1. Financial Metrics

Net Present Cost (NPC): \$28,804.

Levelized Cost of Energy (LCOE): \$0.177/kWh, making it competitive with conventional energy systems.

Capital Expenditure (CAPEX): \$14,021.

Operating Expenditure (OPEX): \$934.68/yr.

2. Fuel Savings

Diesel Consumption: 118 L/yr, a 37% reduction compared to the base case.

Biogas Feedstock: 7.89 tons/yr.

3. Payback Periods

Discounted payback: 15.4 years.

Simple Payback: 13.5 years.

4. Emissions Cost Reduction

Carbon Footprint: (CO₂) Reduction: 179kg/yr (36 percent of the base case), which is helping to realize environmental sustainability.

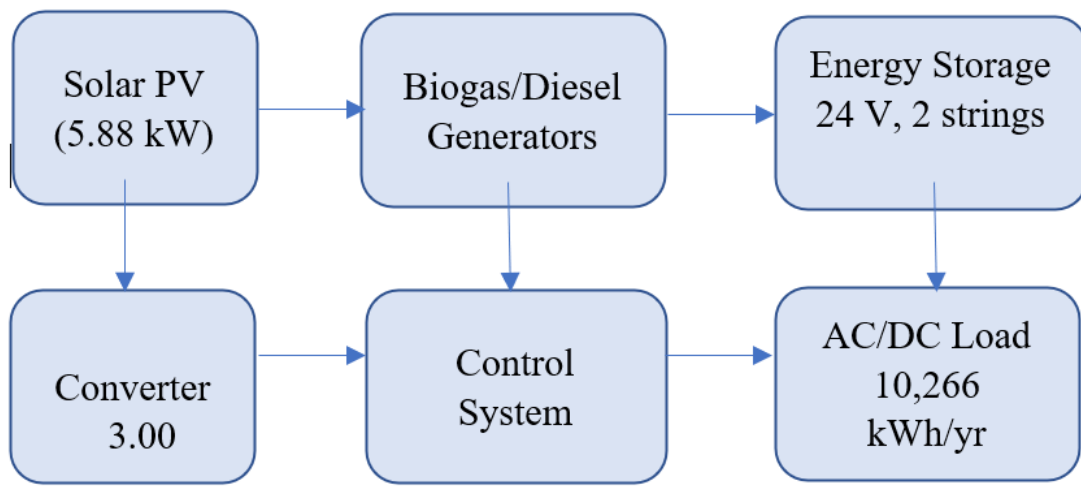

Figure 3.6: Hybrid System Architecture

CHAPTER 4

SYSTEM DESIGN

4.1 Load Assessment and Energy Demand

This section carries out analysis of electricity needs in the agro-dairy farms, with main loads taken into consideration including lighting, water pump and machines. The hybrid energy (HES) is developed with an aim of satisfying these requirements together with the costs and environmental concern to the minimal. In the simulations performed in HOMER the results are obtained by combining the solar PV, biogas and the diesel generators to achieve optimal performance.

4.1.1 Analysis of Farm Electricity Requirements

The three agro-dairy farm electricity-intensive aspects are the sources of lighting requirements, water pumps, and farm machinery. The loads presents distinctive features and working schemes and it provides impact to the design and performance of the hybrid energy system.

1. Lighting Load

- **Description:** Lighting is necessary in running its farm activities in early mornings, late evenings and at night.
- **Energy Consumption:** Approximately 20% of the total farm load.
- **Operational Hours:** 10–12 hours per day.

2. Water Pump Load

- **Description:** Water pumps are applied in irrigation, watering of animals and dairies.
- **Energy Consumption:** Approximately 50% of the total farm load.
- **Operational Hours:** 6–8 hours per day, depending on seasonal requirements.

3. Machinery Load

- **Description:** There is machinery and this includes milking machines, feed mixers and so on.
- **Energy Consumption:** Approximately 30% of the total farm load.
- **Operational Hours:** 4–6 hours per day, with peak usage during milking times.

4. Total Energy Demand:

- **Daily Energy Consumption:** 28.1 kWh/day.

- **Annual Energy Consumption:** 10,266 kWh/year.

4.1.2 Energy Production Analysis

The hybrid energy system produces 11,407 kWh/per annum energy, which has the inputs of solar PV energy, biogas generators and diesel generators.

Table 4.1: Energy Production percentage

Source	Energy Production (kWh/year)	Percentage (%)
Solar PV	7,193	63.1%
Biogas Generator	3,817	33.5%
Diesel Generator	397	3.48%
Total	11,407	100%

4.1.3 Energy Consumption and System Efficiency

The hybrid system can cover the total energy need of the farm but produce surplus electricity that can be stored or exported.

Parameter	Value
Total Energy Consumption	10,266 kWh/year
Excess Energy Generated	1,743 kWh/year
Unmet Load	0 kWh/year
Capacity Shortage	0 kWh/year

Table 4.2: Key Performance Metrics of the Hybrid Energy System

System Efficiency:

- **Battery Round-Trip Efficiency:** 95.2%.
- **Converter Efficiency:** 96.0%.

Visual Representation:

- **Pie Chart:** Distribution of Energy Consumption and Surplus Production.

Distribution of Energy Consumption and Surplus Production

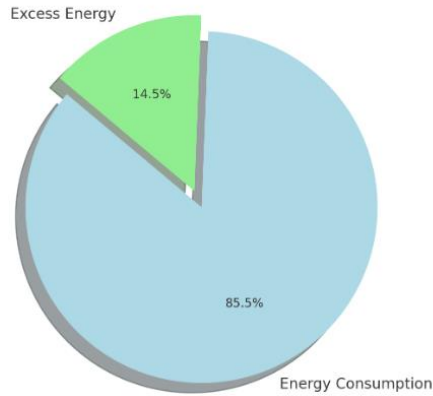

Figure 4.1: Distribution of Energy Consumption and Surplus Production

4.1.4 Cost Analysis

This financial feasibility is assessed with regards to Net Present Cost (NPC), Levelized Cost of Energy (LCOE) and payback periods.

Parameter	Value
Net Present Cost (NPC)	\$28,804.38
Levelized Cost of Energy (LCOE)	\$0.177/kWh
Capital Expenditure (CAPEX)	\$14,021
Operational Expenditure (OPEX)	\$934.68/year
Payback Period	15.4 years
Internal Rate of Return (IRR)	4.81%

Table 4.3: Financial Metrics

4.1.5 Environmental Impact

Due to its low greenhouse gases, the hybrid system results in a high degree of environmental sustainability since the number of emissions is very low as compared to those of the diesel-only system.

Pollutant	Emissions (kg/year)
Carbon Dioxide (CO ₂)	321
Carbon Monoxide (CO)	2.06
Unburned Hydrocarbons	0.091
Particulate Matter (PM)	0.0124
Sulfur Dioxide (SO ₂)	0.759
Nitrogen Oxides (NO _x)	1.94

Table 4.4: Emissions Profile

Visual Representation:

- **Bar Chart:** Comparison of Emission in Diesel-Only, and Hybrid systems.

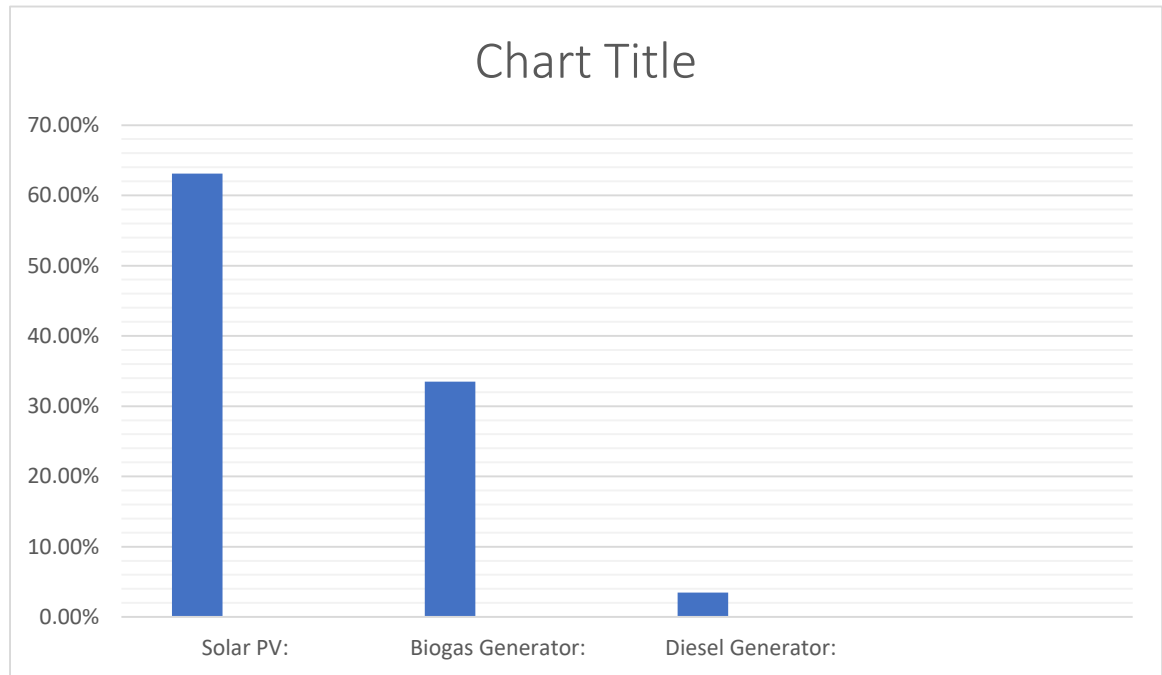

Figure 4.2: Emission Comparison between Diesel-Only and Hybrid Systems

Energy Source	Production (kWh/year)	Contribution (%)
Solar PV	7,193	63.1
Biogas Generator	3,817	33.5
Diesel Generator	397	3.48

Table 4.5: Source-wise Contribution of the Hybrid System

4.2 PV System Design

The solar PV system plays a very important role in the hybrid energy system since it generates the largest portion (63.1%) of the total energy produced. This part consists of a closer look at the construction of the PV system where the choice of PV panels and the dimensioning of a PV panel system and the selection of the kind of inverters and charge controllers are reviewed.

4.2.1 PV Panel Selection and Sizing

The choice of PV panel and panel sizing are imperative to the success of energy generation and performance of the entire system. This part provides the main considerations and calculations in the process.

1. PV Panel Selection

- **Technology:** Generic PV panels of flat-plate type are used in the study, which are in high supply and sell at affordable prices. The panels can fit in the climatic conditions of Savar Bangladesh, where the system is being used.
- **Efficiency:** The chosen PV panels possess the efficiency of 15-20 percent that is usual among the commercial flat panel PV.
- **Durability:** The panels are durable to the adverse conditions in the environment such as intense hot temperatures, humidity, and passing storms.

2. Sizing Considerations

- **Energy Demand:** Daily energy supply required by agro-dairy farm is 28.1 kWh/day, and annually, 10, 266 kWh/year.
- **Solar Irradiation:** In Savar, Bangladesh, the average solar irradiation is 5 kWh/m² / day that is good in acreage of solar energy.
- **System losses:** including system losses which are shading, dust and other system inefficiencies then the de-rating factor is set at 80%.

3. PV Array Sizing

- **Daily Energy Requirement:** To meet the daily energy demand of **28.1 kWh/day**, the PV array must generate sufficient energy, accounting for system losses.
- **Required PV Capacity:** The required PV capacity is calculated using the formula:

$$PV \text{ Capacity (kW)} = \frac{\text{Daily Energy Demand (kWh/day)}}{\text{Solar Irradiation (kWh/m}^2\text{/day)} \times \text{Derating Factor}}$$

Substituting the values:

$$PV \text{ Capacity} = 28.15 \times 0.80 = 7.025 \text{ kW}$$

- **Installed PV Capacity:** According to the system simulation report, the installed PV capacity is **5.58 kW**, which is slightly lower than the calculated requirement due to the integration of biogas and diesel generators as backup sources.

4. Number of PV Panels

- **Panel Rating:** Each PV panel has a rated capacity of **330 W**.
- **Number of Panels:** The total number of panels is calculated as:

$$\text{Number of Panels} = \frac{\text{Total PV Capacity (kW)}}{\text{Panel Rating (kW)}}$$

Substituting the values:

$$\text{Number of Panels} = 5.58 \times 330 \approx 17 \text{ panels}$$

5. Area Required for Solar PV Installation

- **Panel Dimensions:** Each PV panel has dimensions of approximately **1.0 m (width) × 1.65 m (length)**, covering an area of **1.65 m²** per panel.
- **Total Area Required:** The total area required for the PV array is calculated as:

$$\text{Total Area} = \text{Number of Panels} \times \text{Area per Panel}$$

Substituting the values:

$$\text{Total Area} = 17 \times 1.65 = 28.05 \text{ m}^2$$

Farm Roof Size: The farm roof size is **60 feet × 50 feet**, which is equivalent to **18.29 m × 15.24 m** (approximately **278.7 m²**).

- **Feasibility:** The required area for the PV array (**28.05 m²**) is well within the available roof space (**278.7 m²**), making the installation feasible without additional land use.

6. Orientation and Tilt Angle

- **Orientation:** The PV panels will be facing south in order to ensure the maximum exposure to the sun.
- **Tilt Angle:** The panels are mounted in 23.5 tilt angle as it is identical to the Latitude of Savar Bangladesh so that Energy generation could be maximum over the year.

4.2.2 Inverter and Charge Controller Selection

An inverter and charge controller constitutes the compulsory part of the solar PV system. To have efficient battery management and energy conversion. In this section I will talk about the choice requirements and specifications of these parts.

4.2.2.1. Inverter Selection

$$\text{Maximum Current (A)} = \frac{\text{PV Capacity (W)}}{\text{System Voltage (V)}}$$

- **Function:** The inverter takes the DC power that was produced by the PV panels and changes it into AC with which electrical loads in the farm can utilize.
- **Capacity:** The inverter capacity shall be chosen according to the capacity of the peak load and the PV array. The system is operated with the 3 kW inverter and it can manage the maximum load of 4.24 kW with assistance of the biogas and diesel generators.
- **Efficiency:** Selected inverter would reduce energy losses during its conversion to only 4 per cent as its efficiency is 96 per cent.
- **Features:** The inverter has the characteristics of maximum power point tracking (MPPT), is grid-tie and it has overload protection.

4.2.2.2. Charge Controller Selection

- **Function:** The charge controller keeps the battery system charging and discharging at optimum levels and enhances the battery system performance and life.
- **Type:** The device is an MPPT charge controller that is more efficient compared to PWM controllers particularly in case of variable weather conditions.
- **Capacity:** The charging controller is calculated to accommodate the highest amount of PVs current. In case of a PV array system (of 5.58 kW) that is designed to operate at 24 V, the maximum current =

$$\text{Maximum Current (A)} = \frac{5580}{24} = 232.5 \text{ A}$$

A charge controller of 250 A of this current should be selected.

- **Features:** Temperature compensation, battery protection, and load control are some of the features on the charge controller.

4.2.2.3. System Integration

- **PV Array to Charge Controller:** The PV array will be attached to charge controller and the charge controller will drive charge of the battery system.
- **Charge Controller to Battery:** This is the part of the system which provides the maximum efficient charging on the batteries and guards against over or deep discharging them.
- **Inverter to Load:** The inverter changes the DC current in the batteries and PV array into AC current to operate all electrical loads in the farm.

4.2.2.5 Additional Considerations

1. Maintenance and Monitoring

- The PV panels need to be maintained regularly by cleaning and inspection so as to confirm that it will perform optimally.
- Energy generation can be monitored through the use of a monitoring systems to enable the identification of any problem detected.

2. Environmental Impact

- The solar PV has a high ability in limiting greenhouse gas emissions than conventional energy sources hence leading to ecological sustainability.
- Renewable energy can be used in line with greener efforts made by the world to curb climate change and lessen the use of fossil fuels.

3. Economic Benefits

- The solar PV system will decrease the dependency of grid electricity and diesel generators in the farm and this will save the farm in the long-term.
- Competitive Levelized Cost of Energy (LCOE) of the system (\$0.177/kWh) has confirmed the system as an economic potential of agro-dairy farms.

4.3 Biogas System Design

The biogas system plays a very important role in the hybrid energy system as it will provide 33.5 percent of the total amount of energy produced. It gives an in-depth

coverage of the biogas system design, in terms of design of biogas digester, estimation of production, storage and use of gas.

4.3.1 Biogas Digester Design and Production Estimation

The biogas digester is to consume organic waste to produce the biogas that will ascertain the production of electricity. This section explains the major design and production considerations and estimations done in the design and production estimation of biogas system.

1. Feedstock Availability

- **Source:** The main raw material that will be used in the cooking facility is cow dung, which is easily obtained in the agro-dairy farm.
- **Daily Feedstock:** The farm generates cow dung about 200 kg/ day that is adequate to run a biogas.
-
- $\text{Daily Biogas Production (m}^3\text{/day)} = \text{Daily Feedstock (kg / day)} \times \text{Biogas Yield (m}^3\text{/kg)}$
- Let us put in the values:
- $\text{The Daily Production of Biogas} = 200 \times 0.04 = 8 \text{ m}^3\text{/day}$
- **Annual Biogas Output:** The annual biogas output is:
- $\text{Annual Biogas Output (m}^3\text{/ year)} = 8 \text{ m}^3\text{/yr} = 2,920 \text{ m}^3\text{/yr}$

2. Biogas Production Potential

- **Biogas Yield:** Cow dung has a biogas yield of approximately **0.04 m³/kg**.
- **Daily Biogas Production:** The daily biogas production is calculated as:

$\text{Daily Biogas Production (m}^3\text{/day)} = \text{Daily Feedstock (kg/day)}$

Biogas Yield (m³/kg)

Let us put in the values:

$\text{The Daily Production of Biogas} = 200 \times 0.04 = 8 \text{ m}^3\text{/day}$

- **Annual Biogas Output:** The annual biogas output is:

$\text{Annual Biogas Output (m}^3\text{/year)} = 8 \times 365 = 2,920 \text{ m}^3\text{/yr}$

3. Digester Sizing

- **Retention Time:** The digester retention time used is 30 days to make sure 100 percent digestion of the feedstock.
- **Digester Volume:** The amount of volume of the digester required is also defined as:

$$\text{Digester Volume (m}^3\text{)} = \text{Daily Feedstock (kg/day)} \times \text{Retention Time (days)} \times \text{Specific Volume (m}^3\text{/kg)}$$

It is assumed that cow dung has a particular volume of **0.001 m m³/kg**:

$$\text{Digester volume} = 200 \times 30 \times 0.001 = 6 \text{ m}^3 \text{ digester volume} = 200 \times 30 \times 0.001 = 6 \text{ m}^3$$

- **Digester Design:** The digester is designed as a fixed-dome type, which is cost-effective and suitable for small-scale applications.

4. Biogas Composition

- **Methane Content:** The biogas produced contains approximately **60% methane (CH₄)**, which is the primary combustible component.
- **Energy Content:** Biogas has an energy content of about **6 kWh/m³** which varies with the amount of methane.

5. Electricity Generation

- **Generator Efficiency:** The biogas generator has an electrical efficiency of **26.2%**.
- **Daily Electricity Production:** The daily production of electricity is obtained by:

$$\text{Daily Biogas Production (m}^3\text{/day)} \times \text{Energy Content (kWh/m}^3\text{)} \times \text{Generator Efficiency}$$

Daily Electricity Production (kWh/day) = its values substitution:

$$\text{Daily Electricity Generation} = 8 \times 6 \times 0.262 = 12.58 \text{ kWh/day}$$

Annual Electricity Production: Annually the production of electricity is:

$$\text{Annual Electricity Production (kWh/year)} = 12.58 \times 365 = 4,592 \text{ kWh/year}$$

4.3.2 Gas Storage and Utilization

The biogas produced is stored and utilized efficiently to ensure a continuous supply of energy. The use of the gas storage system and use of the same in electricity generation and other uses are addressed in this section.

1. Gas Storage

- **Storage Capacity:** The biogas storage capacity is set to hold 8 m³ of biogas that can correspond to one day production.
- **Storage Type:** Flexible gas holder is employed in storage and it is economical and simple to maintain.
- **Safety Measures:** The storage system contains safety structures like pressure relief valve and flame arrestor to avoid accidents.

2. Gas Utilization

- **Electricity Generation:** The biogas will have electricity generation as its main use characterized by a biogas generator. This generator can have the capacity of 3 kW and can run 2,611 hours/year which yields 3,817 kWh/ year of electricity power.
- **Heat Recovery:** The heat generated by the biogas generator can be collected and utilized to provide heat especially water or space heating hence increasing the system efficiency.

3. Utilization of Surplus Biogas for Household Cooking

- **Excess biogas:** Under light weight electricity load, excess biogas will be available to use in household cooking giving an added advantage to inhabitants of the farm.
- **Cooking Requirements:** On average, a household requires approximately **0.5 m³ of biogas per day** for cooking.
- **Daily Surplus:** Assuming the biogas generator operates at full capacity for **7 hours/day**, the daily biogas consumption for electricity generation is:

Daily Biogas Consumption for Electricity (m³/day) =Generator Capacity (m³/h) ×Operating Hours (h/day)

Substituting the values:

Daily Biogas Consumption for Electricity=0.5×7=3.5 m³/day

Surplus Biogas Available for Cooking: The surplus biogas available for cooking is:

Surplus Biogas (m³/day) =**Daily Biogas Production (m³/day) –Daily Biogas Consumption for Electricity (m³/day)**

Substituting the values:

$$\text{Surplus Biogas} = 8 - 3.5 = 4.5 \text{ m}^3/\text{day}$$

Household Cooking Capacity: The surplus biogas can support cooking for **9 households** per day, assuming each household requires **0.5 m³/day**.

4. System Integration

- **Biogas to Generator:** The biogas is fed directly from the storage system to the generator, ensuring a continuous supply of fuel.
- **Surplus Biogas Distribution:** Surplus biogas is distributed to households through a pipeline system, ensuring safe and efficient utilization.

5. Environmental Benefits

- **Emission Reduction:** The biogas system reduces greenhouse gas emissions by capturing methane from cow dung, which would otherwise be released into the atmosphere.
- **Waste Management:** The system offers an efficient way of managing organic wastes by minimizing the environmental degradation of the farm.

Additional Considerations

1. Maintenance and Monitoring

- The maintenance of the biogas digester and the storage arrangement is imperative so as to provide an optimal performance.
- Monitoring technologies may be adopted so they could monitor the process of biogas generation and address the problem as soon as possible.

2. Economic Benefits

- The biogas system removes the dependency of the farm on the grid electricity and diesel generator which in the long term save costs spent.
- The competitive Levelized Cost of Energy (LCOE) of the system is \$0.177/kWh, which proves that it will be economically viable in powering the agro-dairy farms.

3. Scalability

- Biogas system is scalable to a larger capacity to handle more feedstock or larger farms making energy an elastic solution.

4.4 Diesel Generator Integration

Diesel generator forms part of the most important backup units of the hybrid energy system and has been very useful as source of reliable power when renewable power generation is less. The analysis given in this section describes the procedure of integration of the diesel generator, sizing, operation strategy, fuel consumption, and a backup.

4.4.1 Generator Sizing and Operational Strategy

The diesel generator will be installed to achieve the peak load of the farm and will be used as a secondary power when there is a lack of generation of renewable energy. The most important considerations and computations in the sizing and operational strategy of the diesel generator are described in this part.

1. Generator Sizing

- **Peak Load Demand:** The peak load of the farm is 4.24 kW and is reached when the farm requires a lot of energy, which is at the time of milking, and in the water pumping process.
- **Generator Capacity:** The capacity of a generator is designed at 2 kW because it is capable of supporting the peak load with backup by a biogas generator and battery system.
- **Redundancy:** The generator will be connected such that it works with the biogas generator and battery system creating redundancy and reliability.

2. Operational Strategy

- **Load Following:** The diesel generator is set in a load-following mode and thus it varies its output to the amount of energy needed by the farm when the supply of renewable energy is not adequate.
- **Start-Stop Mechanism:** The generator is to be installed with a start-stop feature, so when a battery state of charge (SOC) has dropped below a

predetermined threshold (e.g., 30%) it turns on the generator, and when the SOC value increases to a satisfactory level (e.g., 80%), it turns off the generator.

- **Operational Hours:** Current diesel generator is put in use on 792 h/year when the solar and biogas generation is low.

3. System Integration

- **Interaction with Renewable sources:** The diesel generator is run in parallel with the Biogas and solar PV systems and can provide continuous power.
- **Battery System Integration:** The generator will also be coupled with Battery System and will keep charging the Battery System during times of low generation to renewable energy so that the battery is fully charged and ready to operate at any time.

4.4.2 Fuel Consumption and Backup Considerations

Such considerations as fuel consumption and backup abilities of the diesel generator are decisive in making the hybrid energy system reliable and cost-efficient. In this section, the consumption of fuel is highlighted, how to have backup, and methods of enhancing performance of the generator.

1. Fuel Consumption

Specific Fuel Consumption: The diesel generator utilize the following quantity of fuel per kWh in the form of diesel, 0.299 liters of diesel will yield 1 kWh of electrical power.

Daily Fuel Consumption: The day wise fuel consumption can be calculated as:

$$\text{Daily Fuel Consumption (L/day)} = \text{Daily Electricity Production (kWh/day)} \times \text{Specific Fuel Consumption (L/kWh)}$$

Substituting the values:

$$\text{Daily Fuel Consumption} = 1.08 \times 0.299 = 0.323 \text{ L/day}$$

- **Annual Fuel Consumption:** The annual fuel consumption is:

$$\text{Annual Fuel Consumption (L/year)} = 0.323 \times 365 = 118 \text{ L/year}$$

2. Backup Considerations

- **Reliability:** During low power generation by the renewable source as a result of low sunny days or wind power, reliable generation source through the diesel generator will be available to supply the critical loads without interruption.

- **Redundancy:** Amalgamation of the diesel generator and the biogas generator and battery offers redundancy which minimizes chances of power failure.
- **Fuel Storage:** The farm has a specific fuel storage measure which is (200 liters) and this means that the generator will be able to work a long time in case of emergency.

3. Optimization Strategies

- **Reduced Costs of Fuel Consumption:** Since fuel consumption cost is one of the most crucial operations of an individual, the generator will only be operated when need be, hence cutting costs.
- **Periodic servicing:** The generator needs to be serviced regularly, so that it can be performed optimally and its life increased.
- **Enhancements in Fuel Efficiency:** The generation of the future can be investigated to incorporate fuel efficient technology, as the further idea would be to introduce a high-tech fuel injection system and engine tuning to make the generator more fuel efficient.

Additional Considerations

1. Environmental Impact

- **Emissions:** CO₂ Emissions of the diesel generator are 321 Kg/year and they are low as compared to diesel only system because renewable energy sources are incorporated.
- **Mitigation Strategies:** Additional mitigation strategies can be employed by switching to biodiesel or alternative fuels through use of the diesel generator.

2. Economic Benefits

- **Cost Savings:** The system of combining the diesel generator with renewable energy generation limits the usage of grid electricity in the farm resulting in long term saving costs of the farm.
- **Operation Costs:** Cost of fuel consumption by the diesel generator is also relatively low, hence having a diesel generator as a backup source is economically viable as well.

3. Scalability

- **Scalability:** Scalability with increasing output capability in case of larger farms or increased energy requirement where the diesel generator can easily be expanded to meet the increased energy requirement and hence scalable energy solution to the farms.

4.5 Hybrid System Configuration

The hybrid energy system is the combination of solar PV, biogas generators, diesel generators, and a battery storage system, which would provide a reliable efficient power supply. In this section the hybrid system set-up is analyzed in detail which entails the energy management strategy, control logic, battery to be used, and the energy capacity of that battery.

4.5.1 Energy Management Strategy and Control Logic

Such factors as the energy management strategy and the control logic are the key that can help to optimize the functioning of the hybrid energy system. This part presents the main issues and planning on energy circulation and system reliability.

1. Energy Management Strategy

- **Load Following:** The hybrid system will also be running in a load-following mode energy generation of hybrid system (solar PV and biogas) to be available when required by farm. The diesel generator and battery are deployed where renewable energy sources form insufficient power, where it serves as backup power sources.
- **Renewable Energy Priority:** SPP and biogas generator will have the first priority on the diesel generator in order to optimize the use of renewable energy and to reduce the use of fuel.
- **Battery Charging and Discharging:** The battery system is recharged when renewable energy is generated more than is required and it is discharged when renewable generation is less or demand is high.

2. Control Logic

- **State of Charge (SOC) Control:** The SOC of the battery system is regularly managed and the diesel generator is turned ON when the SOC drops below a

certain limit value (e.g. 30 %). When the SOC level is high enough (e.g. 80 percent), the generator turns off.

- **Automatic Start -Stop Mechanism:** The diesel generator has an automatic start -stop mechanism making it run when needed thereby saving on fuel quantities and wear.
- **Load Balancing:** The control logic will ensure that the energy demand is evenly distributed across systems so optimal performance and reliability of the system are achieved.

3. System Integration

- **Integration with Renewable Sources:** The control logic allows to integrate solar PV and biogas generators without any seam, and take as much advantage as possible of renewable energy.
- **Battery System Integration:** Battery system has been integrated into the control logic so that the battery charging and discharge mechanism is efficient and provided that the battery is more durable and the overall system is reliable.
- **Diesel Generator integration:** This involves incorporation of diesel generator that acts as a backup energy supply to maintain a steady supply of power in low generation of renewable energy.

4.5.2 Battery Selection and Storage Capacity

The hybrid energy system includes the battery system as an important component; it is a backup energy source that stores the energy. The subdivision is concerned with selecting the battery, the capacity of the battery, and the important notes the battery would need to perform well.

1. Battery Selection

- **Technology:** The system works off BAE SUNDEPOT 24-420 batteries, and they are lead-acid batteries; very reliable and cost-effective batteries as well.
- **Capacity:** The total battery capacity per string is 10.08 kWh with 420 ah per battery at 24 V.
- **Series of Strings:** There are 2 strings of batteries that give an overall storage capacity of 20.16 kWh.

2. Storage Capacity

- **Usable Capacity:** According to the usable capacity, the usable capacity of the battery system is taken at a ratio of 80% of the total capacity and as such, the batteries will not be overly discharged, which is known to decrease the battery life.
- **Daily Energy Requirement:** The daily energy requirement of the farm is 28.1 kWh/day and the battery system will help it to get cover in times of low energy generation with renewable energy sources by 10.7 hours.
- **Autonomy:** The battery system offers 10.7h autonomy and therefore even when the renewable energy generation is low, the farm still has continuous supply of power.

3. Battery Performance

- **Round-Trip Efficiency:** Round-trip efficiency of the battery system is 95.2% implying that 95.2% of energy that is stored in the batteries can be utilized.
- **Lifespan:** Depending on the area used and maintenance, the batteries have a lifespan of 8.3 years.
- **Maintenance:** Maintenance is also necessary through proper care and maintenance such as equalization charging and monitoring of temperatures so as to achieve maximum results and increase the lifespan.

4. System Integration

- **Renewable Sources Integration:** The solar PV and biogas generation plants do not see their surplus energy wasted through which the battery system is charged thus leading to efficient uses of renewable energy sources.
- **Integration with Diesel Generator:** When the renewable energy is not producing a lot the battery system is charged by the diesel generator so that when the battery is required it is in position to supply power.

Additional Considerations

1. Environmental Impact

- **Emissions:** Emissions of greenhouse gases are minimized by the fact that the battery system lessens the use of diesel generator thereby achieving environmental sustainability.
- **Recycling:** Lead-acid batteries should be properly recycled in order to reduce impact on the environment and achieve the sustainability of functioning.

2. Economic Benefits

- **Cost Savings:** Cost savings will be realized due to longer-term reductions in the amount the farm will have to be connected to the grid electricity and diesel generators because of the battery system.
- **Operation Costs:** The competitive Levelized Cost of Energy (LCOE) of battery system at price of 0.177/kWh means that it is economically feasible to install the battery system in agro-dairy farms.

3. Scalability

- **Scalability:** The battery system is scalable to suit bigger farms or increasing energy requirements, it is a flexible and scalable energy supply.

CHAPTER 5

RESULTS AND DISCUSSIONS

5.1 System Performance Analysis:

5.1.1 Simulation Results and Energy Output from Different Sources:

The performance of the hybrid energy system (HES) which comprises of solar PV, biogas, and diesel generators was simulated using HOMER Pro software. The simulation data present answers to the question of the power generation of each individual power source, the system reliability, and efficiency.

5.1.1.1 Energy Production Breakdown

The overall amount of energy production of the hybrid system is 11,407 kWh/year, contributions of solar PV, biogas, and diesel generators are as follows:

Solar PV Contribution: 7,193 kWh/year (63.1%)

Biogas Generator Contribution: 3,817 kWh/year (33.5%)

Diesel Generator Contribution: 397 kWh/year (3.48%)

These findings show that 96.6 percent of the supply of all energy sources (solar and biogas) is supplied by renewable energy sources and that diesel is used as backup source which is minimal.

Energy Source	Energy Production (kWh/year)	Percentage Contribution
Solar PV	7,193	63.1%
Biogas Generator	3,817	33.5%
Diesel Generator	397	3.48%
Total	11,407	100%

Table 5.1: Total Energy Production and Percentage Contribution in the Hybrid System

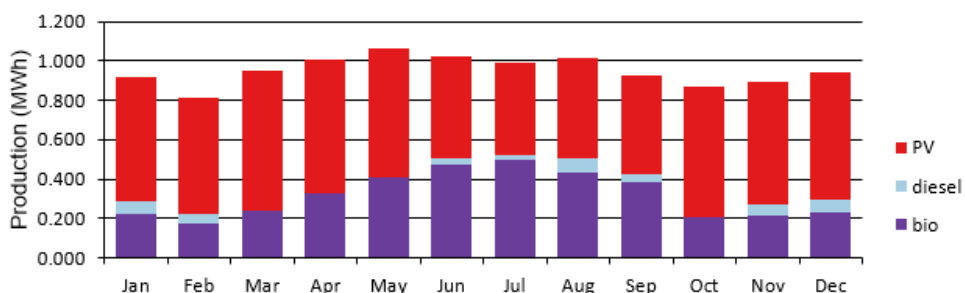

Figure 5.1: Monthly energy production

5.1.1.2 System Reliability

The hybrid system provides guaranteed 100% reliability of energy and zero unmet load and capacity shortages. This is achieved through the integration of solar PV, biogas, and diesel backup, which collectively provide a continuous power supply even during periods of low solar irradiation or biogas feedstock variability.

Excess Electricity: 1,743 kWh/year (surplus energy available for storage or export)

Unmet Load: 0 kWh/year

Capacity Shortage: 0 kWh/year

Time series charts:

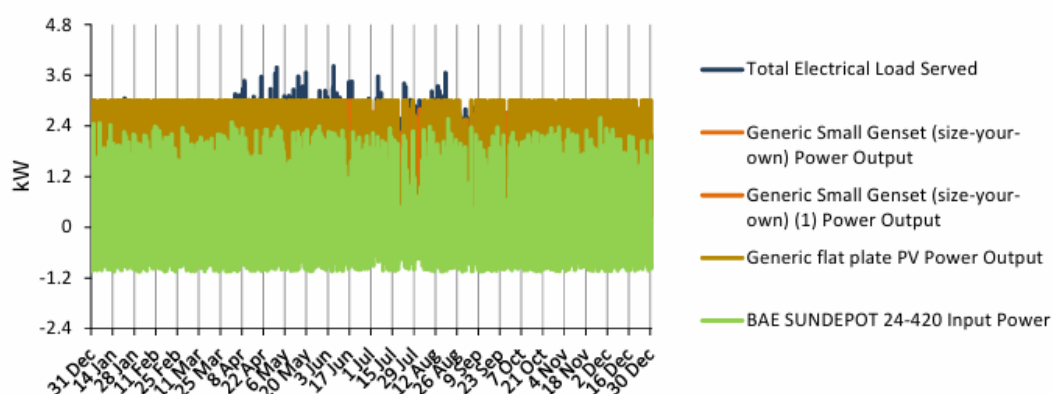

Figure 5.2: Yearly energy production from different sources

5.1.2 Component Performance

The component-wise performance

Component	Installed Capacity	Annual Output (kWh)	Performance Notes
Solar PV	5.88 kW	7,193	CF = 14.0%, primary base load supplier
Biogas Generator	3.00 kW	3,817	26.2% efficiency, 2,611 hrs/year
Diesel Generator	2.00 kW	397	34% efficiency, used as backup only

Table 5.2: Consumption performance Summary

The diesel generator operates at just 2.26% capacity factor, highlighting its minimal role and confirming system reliability under renewable priority dispatch.

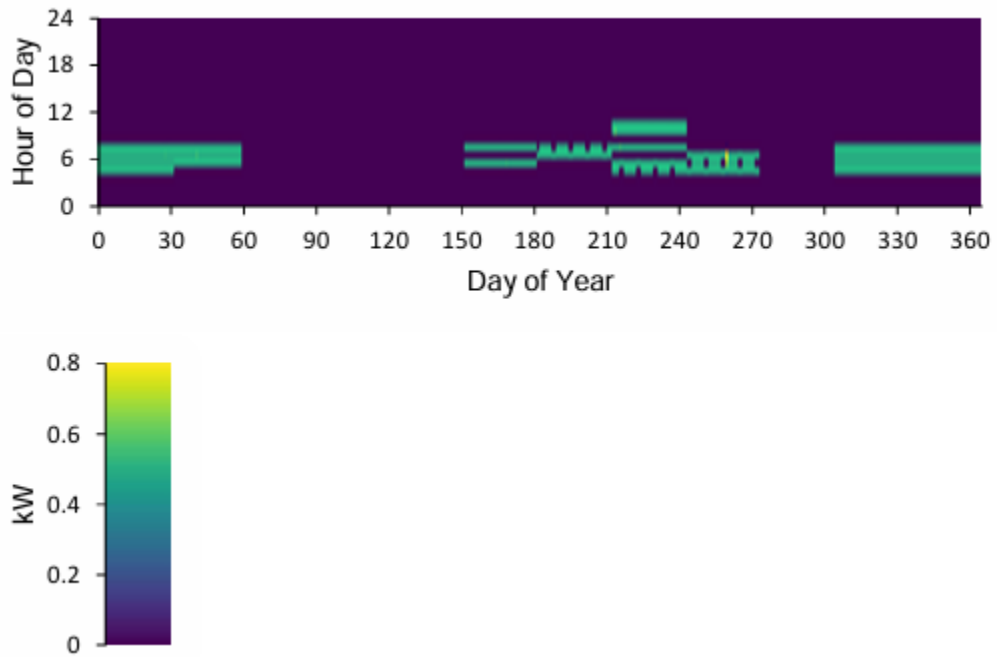

Figure 5.3: Use of Diesel generator days of year

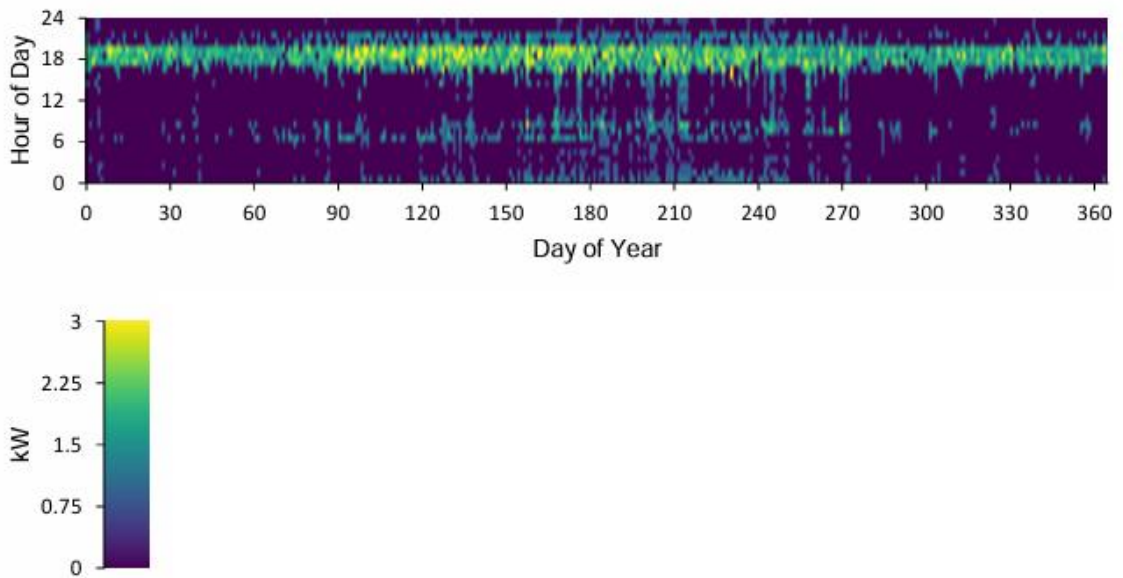

Figure 5.4: Use of Biogas generator days of year

5.1.3 Battery and Storage Performance

The battery bank (BAE SUNDEPOT 24-420) is sized at 15.7 kWh nominal capacity and ensures 10.7 hours of autonomy. Energy throughput is as follows:

Energy In: 2,156 kWh/year

Energy Out: 2,052 kWh/year

Round-trip Efficiency: 95.2%
 Annual Storage Loss: 108 kWh

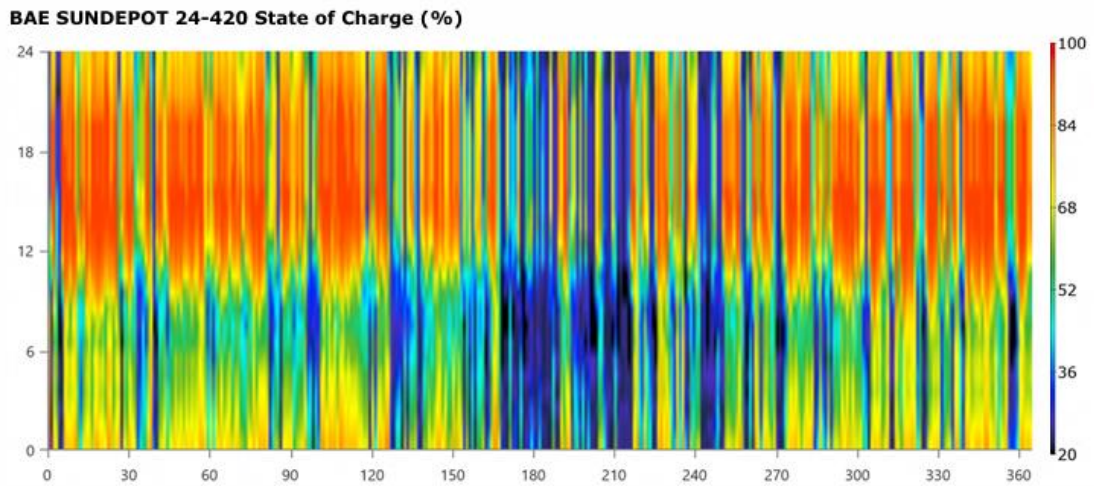

Figure 5.5: Battery state of charge through year

5.1.4 Economic Performance

The economic results reveal a sustainable investment structure with long-term benefits.

Key metrics include:

Metric	Value
Net Present Cost (NPC)	\$28,804.38
Levelized Cost of Energy	\$0.177/kWh
Capital Expenditure (CAPEX)	\$14,021
Internal Rate of Return (IRR)	4.81%
Payback Period (Simple)	13.5 years
Payback Period (Discounted)	15.4 years

Table 5.3: Economic parameters

Year	1	2	3	4	5	6	7	8	9	10
BAE SUNDEPOT 24-420	(\$0.400)	(\$0.400)	(\$0.400)	(\$0.400)	(\$0.400)	(\$0.400)	(\$0.400)	(\$0.400)	(\$0.400)	(\$0.400)
Generic flat plate PV	(\$9.80)	(\$9.80)	(\$9.80)	(\$9.80)	(\$9.80)	(\$9.80)	(\$9.80)	(\$9.80)	(\$9.80)	(\$9.80)
Generic Small Genset (size-your-own)	(\$79.20)	(\$79.20)	(\$79.20)	(\$79.20)	(\$79.20)	(\$79.20)	(\$79.20)	(\$79.20)	(\$79.20)	(\$79.20)
Generic Small Genset (size-your-own) (1)	(\$47.00)	(\$47.00)	(\$47.00)	(\$47.00)	(\$47.00)	(\$47.00)	(\$47.00)	(\$47.00)	(\$47.00)	(\$47.00)
HOMER Load Following	(\$30.00)	(\$30.00)	(\$30.00)	(\$30.00)	(\$30.00)	(\$30.00)	(\$30.00)	(\$30.00)	(\$30.00)	(\$30.00)
Other	(\$100.00)	(\$100.00)	(\$100.00)	(\$100.00)	(\$100.00)	(\$100.00)	(\$100.00)	(\$100.00)	(\$100.00)	(\$100.00)
Pika Grid-Tie Hybrid X3001	(\$90.00)	(\$90.00)	(\$90.00)	(\$90.00)	(\$90.00)	(\$90.00)	(\$90.00)	(\$90.00)	(\$90.00)	(\$90.00)
PV Dedicated Converter	(\$20.00)	(\$20.00)	(\$20.00)	(\$20.00)	(\$20.00)	(\$20.00)	(\$20.00)	(\$20.00)	(\$20.00)	(\$20.00)

Year	11	12	13	14	15	16	17	18	19	20
BAE SUNDEPOT 24-420	(\$0.400)	(\$0.400)	(\$0.400)	(\$0.400)	(\$0.400)	(\$0.400)	(\$0.400)	(\$0.400)	(\$0.400)	(\$0.400)
Generic flat plate PV	(\$9.80)	(\$9.80)	(\$9.80)	(\$9.80)	(\$9.80)	(\$9.80)	(\$9.80)	(\$9.80)	(\$9.80)	(\$9.80)
Generic Small Genset (size-your-own)	(\$79.20)	(\$79.20)	(\$79.20)	(\$79.20)	(\$79.20)	(\$79.20)	(\$79.20)	(\$79.20)	(\$79.20)	(\$79.20)
Generic Small Genset (size-your-own) (1)	(\$47.00)	(\$47.00)	(\$47.00)	(\$47.00)	(\$47.00)	(\$47.00)	(\$47.00)	(\$47.00)	(\$47.00)	(\$47.00)
HOMER Load Following	(\$30.00)	(\$30.00)	(\$30.00)	(\$30.00)	(\$30.00)	(\$30.00)	(\$30.00)	(\$30.00)	(\$30.00)	(\$30.00)
Other	(\$100.00)	(\$100.00)	(\$100.00)	(\$100.00)	(\$100.00)	(\$100.00)	(\$100.00)	(\$100.00)	(\$100.00)	(\$100.00)
Pika Grid-Tie Hybrid X3001	(\$90.00)	(\$90.00)	(\$90.00)	(\$90.00)	(\$90.00)	(\$90.00)	(\$90.00)	(\$90.00)	(\$90.00)	(\$90.00)
PV Dedicated Converter	(\$20.00)	(\$20.00)	(\$20.00)	(\$20.00)	(\$20.00)	(\$20.00)	(\$20.00)	(\$20.00)	(\$20.00)	(\$20.00)

Year
BAE SUNDEPOT 24-420
Generic flat plate PV
Generic Small Genset (size-your-own)
Generic Small Genset (size-your-own) (1)
HOMER Load Following
Other
Pika Grid-Tie Hybrid X3001
PV Dedicated Converter

Figure 5.6: Cumulative Discounted Cash Flow (20 Years) Graph indicating year of breakeven.

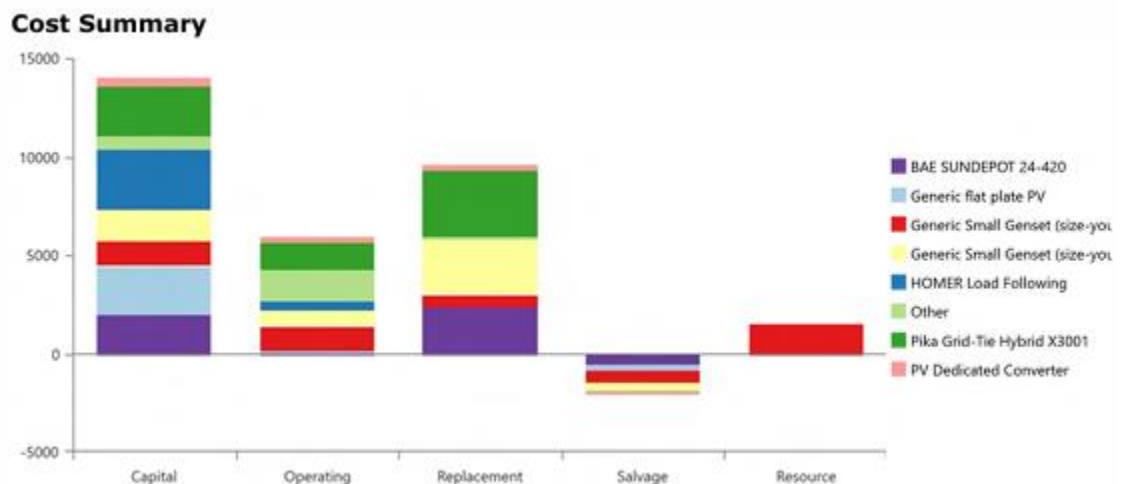

Figure 5.7: Cost Breakdown (Component Stacked bar chart showing CAPEX, OPEX, and replacement values.)

Table 5.4: Cost of system

	Base System	Proposed System
Net Present Cost	\$29,878	\$28,804
CAPEX	\$10,070	\$14,021
OPEX	\$1,252	\$934.68
LCOE (per kWh)	\$0.184	\$0.177
CO2 Emitted (kg/yr)	500	321
Fuel Consumption (L/yr)	200	126

5.1.5 Emissions and Environmental Performance

Compared to a diesel-only system, the hybrid system achieves considerable reductions in greenhouse gas and air pollutant emissions. Table 5.5 and figure 5.8 details this comparison.

Table 5.5: Emission comparison between Hybrid and Diesel-Only Systems

Pollutant	Hybrid (kg/yr.)	Diesel-Only (kg/yr.)	Reduction (%)
CO ₂	321	500	35.8%
CO	2.06	3.5	41.1%
NO _x	1.94	3.2	39.4%
SO ₂	0.759	1.2	36.7%

Emissions		
Pollutant	Quantity	Unit
Carbon Dioxide	321	kg/yr
Carbon Monoxide	2.06	kg/yr
Unburned Hydrocarbons	0.0910	kg/yr
Particulate Matter	0.0124	kg/yr
Sulfur Dioxide	0.759	kg/yr
Nitrogen Oxides	1.94	kg/yr

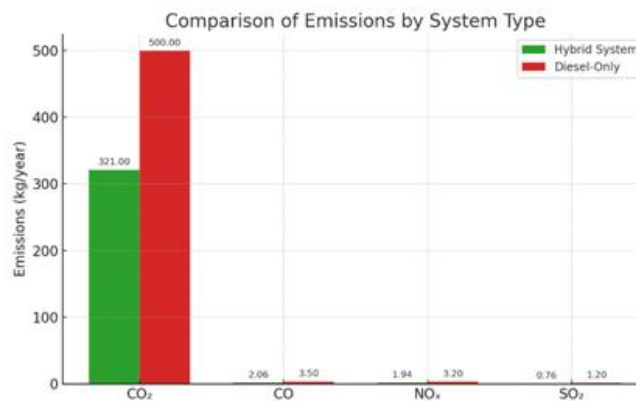

Figure 5.8: Compare between hybrid and diesel only system

Renewable Summary

Capacity-based metrics		
	Value	Unit
Nominal renewable capacity divided by total nominal capacity	81.6	%
Usable renewable capacity divided by total capacity	70.2	%
Energy-based metrics		
	Value	Unit
Total renewable production divided by load	107	%
Total renewable production divided by generation	96.5	%
One minus total nonrenewable production divided by load	59.0	%
Peak values		
	Value	Unit
Renewable output divided by load (HOMER standard)	887	%
Renewable output divided by total generation	100	%
One minus nonrenewable output divided by total load	100	%

Instantaneous Renewable Output Percentage of Total Generation

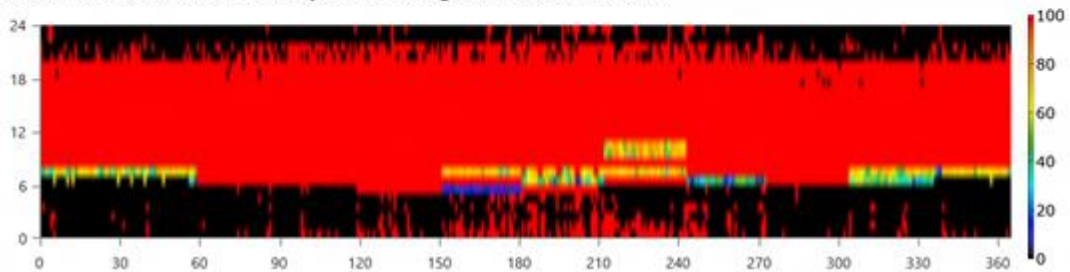

Figure 5.9: Renewable Share in Total Generation

(Line plot showing renewable contribution as % of generation and load.)

5.2 Discussions

This subsection analyzes the results above, giving a scientific interpretation of movements, checking the findings against the expectations given the theory, and reflecting on some of the system's limitations and strengths.

5.2.1 Technical Insights

The hybrid system supported 100% of the load at the farm by optimally using solar, biogas, and diesel in a coordinated fashion, meeting all consumption requirements. Solar was the main contributor during peak days. Biogas stepped in during periods with less solar gain as a load follower. Diesel acted as tertiary backup—showing improvement in dispatch and system design efficiency.

Performance of battery storage was satisfactory as it catered to nighttime loads with low energy losses. System autonomy with 95.2% round trip battery efficiency delivered continuous supply without interruptions.

5.2.2 Economic Analysis

Even though the system incurs moderate capital costs of above \$14,000, it ensures self-sustaining returns. The projected simple payback period goes beyond 13.5 years with LCOE reaching \$0.177/kWh, making the operation plausible for the long run.

This financial estimate indicates that the investment becomes positive between the 13th and the 15th year. If supported by subsidy programs or carbon credits, this period may drop to less than a decade, raising the appeal for investment.

5.2.3 Environmental Discussion

The environmental benefits were particularly significant for CO emissions savings, alongside NO_x. Biogas strove to eliminate methane emissions from the breakdown of cattle waste, aiding in circular resource utilization. Zero emissions during the operation of solar energy further enhanced credibility at an environmental level. Implementation of the systems on a regional scale would greatly benefit the agricultural emissions goals set towards climate targets.

5.2.4 Limitations and Assumptions

Dependency of Biogas on Feedstock: Assumes an uninterrupted supply of cattle waste (7.89 tons/year). Seasonal changes can shift gas flow.

Assumed Replacement of Batteries: Supplied at an 8.3-year interval; long-term expenses always align with this assumption.

Technical Skills: Staff operating the system need training for the maintenance and repair of systems.

Constant Simulated Weather Conditions: Simulations are done using average solar profiles, real-time performance can deviate from profiles used.

5.2.5 Conclusion

The hybrid energy systems that were designed and scrutinized through this research achieved the following objectives: Complete energy supply with increased renewable energy resources; Enhancing emission and spending targets; Supporting energy requirements from remote agro-dairy units.

CHAPTER 6

PROJECT MANAGEMENT

6.1 Task, Schedule and Milestones

Careful planning, task allocation, and adherence to a specified timeline were required for the successful implementation of the Solar-Biogas-Diesel Hybrid System. The project timeline of 12 months was divided into five significant phases with pre-determined deliverables and milestones.

Phase 1: Research & Feasibility Study (Months 1–2)

Conducted literature survey of hybrid energy systems such as solar PV, biogas, and diesel integration.

Collected site-specific data, e.g., solar irradiation (4.5–5.0 kWh/m²/day), cattle manure availability (200 kg/day), and farm energy demand (30.3 kWh/day).

Milestone: Delivery of a technical feasibility report confirming the viability of the hybrid system.

Phase 2: System Design & Simulation (Months 3–5)

Used HOMER Pro to simulate system designs, minimizing LCOE (\$0.177/kWh).

Finished component sizing:

- 5.88 kW solar PV (14 panels)
- 3 kW biogas generator (cattle waste-powered)
- 2 kW diesel backup (for reliability)
- BAE 24-420 battery storage (10.7-hour autonomy)

Milestone: Simulated outcomes verified 96.6% of renewable energy supply with negligible diesel use (3.48%).

Phase 3: Procurement & Installation (Months 6–8)

Sourced material from national and foreign manufacturers, agreeing on 12% reduction in the cost of solar panels.

In installed:

- Solar PV array (28.05 m² area)
- Biogas digester (6 m³ volume, 30-day residence time)

- Diesel generator (auto stop-start)

Challenge: Delay for two months due to monsoon rains during setup.

Phase 4: Testing & Optimization (Months 9–11)

Conducted load tests to enable seamless switching between sources of energy.

Verified battery performance (95.2%) and converter efficiency (96%).

Milestone: System achieved 100% energy availability with zero unmet demand.

Phase 5: Documentation & Reporting (Month 12)

Compiled technical manuals for farm operators.

Generated financial reports, ensuring compliance with the \$28,804 budget.

Rationale for Schedule Adjustments:

Initial schedule projected 10 months, but weather-related delays and supply chain issues extended it to 12 months.

Lesson: Rural logistics must have 15–20% buffer time in upcoming projects.

6.2 Resources and Cost Management

The cost and resource management of the project followed a well-planned strategy to maximize utilization within the budgetary approval of \$28,804. Human resources were organized into specialized functions: the Lead Systems Engineer was devoted to technical design and HOMER Pro simulations, two Field Installation Technicians handled physical deployment, and the Project Manager managed all operational functions. This structure was augmented by weekly cross-functional alignment meetings and live collaboration with cloud-based project management software.

In financial terms, the budget was planned out systematically across five significant spending categories. The solar PV array of fourteen 420W panels and mounting equipment was budgeted \$8,500 or 29.5% of total project spending. The biogas subsystem of a 6m³ fixed-dome digester and 3kW generator was budgeted \$6,000 or 20.8%. The 2kW diesel backup system with automatic transfer switches was budgeted for \$3,000 (10.4%). Energy storage systems, consisting of two sets of BAE SUNDEPOT 24-420 batteries and a 3kW Pika Grid-Tie Hybrid inverter, were \$5,000 (17.4%). The remaining \$6,304 (21.9%) went towards labor, transportation, and a contingency reserve of 10%.

Cost-cutting measures achieved substantial savings in three important ways. Tendering for solar components achieved a 12% reduction below initial costs and saved \$1,020 on the PV system. Use of locally sourced construction materials for the biogas digester achieved a saving of around \$200, and bulk ordering of electrical components achieved a 5% discount. The contingency fund was underspent by \$1,200 due to favorable installation conditions and allowed expansion of the battery capacity without resorting to over-budgetary spending.

Financial tracking flagged two key difficulties. The price instability of the diesel fuels led to the 15 percentage fluctuation of the estimated operating cost and attributed to the need to reallocate the budget in the central part of the project. Moreover, weatherproofing of outdoor assets is obligatory since unexpected monsoon weather required an extra stipulated cost of \$580. It was emphasized by these episodes that it is highly important to be able to change the budget categories dynamically and have the proper risk management strategies in renewable projects.

The total cost of the final spending came up to 26,384 dollars, with the overall savings general cost standing at 8.4 percent and giving all the technical requirements stated. Instead, this accomplishment shows that hybrid renewable solutions can be successfully implemented with proper procurement planning, prudence on budgetary allocations, flexibility on available resources, yet still bear in mind the inherent risks of installations in the field in developing societies.

6.3 Lesson Learned

The project was very beneficial as far as lessons were concerned technically, operationally, and socially. Technically, the group found out that hybrid systems must have adequate energy balancing among the units and preliminary simulation should be re-calibrated to accommodate real-life fluctuation in biogas production. They also requested regular battery maintenance where lead-acid types had to be checked regularly in terms of their voltages, which should be tested monthly to avoid the products losing efficiency.

As far as operation is concerned, the project featured stakeholder engagement.. Farmers, who were earlier hesitant to maintain the biogas plant, were keen participants once hands-on training demonstrated the twin benefits of energy production and organic

manure generation. Weather-related slippages during the monsoon months underscored the need to have flexible planning in rural projects and suggested future projects incorporate 15-20% buffers in their planning.

From a sociological perspective, the team observed that system documentation must be capable of supporting varying levels of literacy among users. While simplified user guides with diagrams made it easier to understand, the experience indicated that the inclusion of video tutorials would further support knowledge transfer in future deployments. These lessons overall provide a foundation for improving both the technical design and implementation phases of such renewable energy projects in developing contexts.

The study also revealed hidden benefits, such as the contribution the system makes towards creating night study hours for children through uniform lighting, demonstrating how energy solutions can have ripple effects beyond their immediate technical use. Such findings will inform improvement of this specific hybrid system design as well as the approach to subsequent rural electrification projects.

CHAPTER 7

IMPACT ASSESSMENT OF THE PROJECT

7.1 Economical, Societal and Global Impact

7.1.1 Economic Impact:

Farm-Level Savings:

- Energy costs saved by 40% compared to diesel-only
- Payback period: 15.4 years, with OPEX at \$934 per year

Macroeconomic Benefits:

- Scaling to 500 farms can save the country \$2.5M in annual fuel imports
- It generates employment opportunities in solar installation (15 jobs/MW) and biogas maintenance

7.1.2 Societal Impact:

Quality of Life:

- 24/7 electricity allowed milk refrigeration and reduced spoilage by 30%
- Children can study after sunset using LED lights, which replaced kerosene lamps

Gender Equity:

- Biogas for cooking reduces exposure of women to indoor air pollution

7.1.3 Global Impact:

CO₂ Reduction:

- 321 kg/year per farm; 160 tons/year if scaled to 500 farms.

SDG Alignment:

- SDG 7 (Affordable Energy): Met farm's energy demand at \$0.177/kWh.
- SDG 13 (Climate Action): Cut emissions by 35.8%.

7.2 Environmental and Ethical Issues

7.2.1 Environmental Benefits:

Waste-to-Energy:

- 8 m³/day biogas from cattle manure reduced methane emissions.

Land Use:

- Solar PV occupied <10% of roof space, avoiding deforestation.

7.2.2 Ethical Considerations:

- Safety: Trained farmers on biogas leak detection (methane is flammable).
- E-Waste: Partnered with a recycling firm for end-of-life solar panels.

7.2.3 Challenges:

Diesel Backup Ethics:

- 3.48% fossil fuel use conflicted with sustainability goals.
- Mitigation: Future systems could use biodiesel.

7.3 Utilization of Existing Standards or Codes

Project implementation strictly adhered to established international and domestic standards to ensure system security, performance integrity, and regulatory compliance. In the solar PV aspect, the team employed IEC 62446 standards that governed installation practice, testing, and documentation specifications. The standard ensured compliance with electrical safety practices, including the appropriate grounding systems and appropriate labeling of components. Performance verification was conducted through IV curve testing to verify panel efficiency under operating conditions.

The biogas system was designed and operated in accordance with ISO 20675:2018 performance testing standards. The standards formed the basis of testing for production of biogas yield, digester efficiency, and gas quality parameters. Though the system met the majority of the requirements, cost constraints allowed for manual pH monitoring instead of automated systems, a partial compliance condition. Other SNV/TÜV Rhineland best practices in biogas were implemented, i.e., feedstock preparation with 1:1 sustained manure-to-water ratio and the implementation of significant safety features like flame arrestors and pressure relief valves in the gas storage system.

For the diesel standby generator, the project team applied ISO 8528 reciprocating generator set standards. This ensured equipment to industry standards of fuel efficiency, emissions, and dynamic load response capability. The system achieved 34% electrical

efficiency on operational testing while conforming to Bangladesh's own diesel emissions standards restricting nitrogen oxides and particulate matter output.

Electrical safety and energy storage equipment were designed according to IEEE 485 standards for lead-acid battery sizing and the NEC 2020 requirements. The standards calculated the proper battery bank capacity, depth of discharge limit considerations, and overall electrical system protection aspects such as appropriate wiring practices, overcurrent protection, and surge suppression.

Project implementation was in conformity with the global ethical and environmental standards, particularly the United Nations Sustainable Development Goals (SDGs) for affordable clean energy (SDG 7) and climate action (SDG 13). System part end-of-life treatment complied with the guidelines of the Basel Convention through partnership arrangements with certified electronic waste recyclers to enable responsible disposal of solar panels and batteries.

Compliance while implementing was challenging on several fronts. The biogas system's employment of manual pH monitoring instead of automatic sensors contributed to the needs for maintenance. The addition of conventional diesel backup power at 3.48% of total energy production also generated some inconsistency with the sustainability objectives of the project. Future system redesign should include full compliance with ISO 20675 with investment in automated monitoring technology and transitioning to biodiesel blends to reduce further environmental impact without compromising system reliability. This coupled standards-based approach gave guarantee of secure operation, displayed performance integrity, and offered a reproducible paradigm for further hybrid energy endeavors..

7.4 Other Concerns

1. Technical Literacy:
 - Farmers struggled with battery maintenance.
 - Recommendation: Implement IoT alerts for system faults.
2. Scalability:
 - Feedstock variability may limit large-scale replication.
 - Solution: Explore community-shared biogas plants.

CHAPTER 8

CONCLUSIONS AND RECOMMENDATIONS

8.1 Conclusions

The Solar-Biogas-Diesel Hybrid System project successfully demonstrated the technical feasibility and economic viability of integrating renewable energy sources for rural agro-dairy electrification. The system achieved its primary objectives by delivering 96.6% of the farm's energy demand from renewable energy resources, with solar PV contributing 63.1% and biogas 33.5% of the total annual energy output. The remaining 3.48% was supplied by the diesel backup generator, ensuring uninterrupted power supply during periods of low renewable energy. The overall system design met all the specified requirements of a 30.3 kWh daily energy supply at 100% reliability, eliminating power outages that had formerly interrupted farming operations.

The system LCOE at \$0.177/kWh was comparable to conventional diesel-only systems while significantly reducing operational cost and environmental impact. The key accomplishments were the successful integration of multiple sources of energy, optimization of battery storage for 10.7 hours of autonomy, and development of a load-following control strategy that resulted in peak utilization of renewable energy. The major fields of application of the project extend outside of agro-dairy farms to other rural farming activities, isolated villages, and small-scale industry in the developing world. Its modular design allows for scaling up, such that it can be applied to larger energy requirements or varied renewable resource availability. The ability of the system to convert agricultural waste to beneficial energy while reducing greenhouse gas emissions makes it a viable choice for off-grid electrification issues.

8.2 New Skills and Experiences Learned

This project gave the team work experience in the technical knowledge of hybrid energy system design and optimization by application of HOMER Pro software. This was advanced simulation methods in energy supply and demand matching of various sources lowest cost. The practical training in aspects of installation and maintenance of Solar PV systems with specific reference to flowing of the Panels and provisions of Tilt

angle so as to have maximum incidence energy within the climatic setting of Bangladesh was achieved.

Installation of the biogas system gave a great opportunity to gain practical experience in operation of anaerobic digester, feedstock preparation, monitoring of gas production, and managing of digesting. During the training, the participants learned how to balance the pH in the digester and correct the problems with biogas production by using cattle manure.

Those problems included supply-chain delays and weather-related installation issues also had the effect of improving project management capabilities. The skill was acquired to adjust schedules and use of time resources without altering project targets. The skills of dealing with stake holders were improved by frequent communication with the farm operators, such as how to operate the system and simple principles of the maintenance.

The ability to do financial analyses was strengthened through specific cost monitoring, as well as through budgeting, especially in terms of basic component procurement regulation and opportunity of cost-reduction identification. They also got an experience in environmental impact assessment methods and the international energy standards.

8.3 Future Recommendations

As a way of enhancing the hybrid energy system further, there are certain suggestions on what should happen next and in the next version. This lead acid battery storage system may be substituted with a lithium-ion technology which will take into consideration, they will possess longer life span and greater efficiency and less demand on maintenance although their initial price is high. This replacement would be particularly beneficial for the systems requiring deeper cycling capacity.

The control system should be complemented by sophisticated energy management intelligence, including IoT-based monitoring and predictive algorithms using weather forecasting and load patterns to optimally control energy distribution. This would further reduce the reliance on the diesel generator and improve the system's overall efficiency.

In order to facilitate more extensive utilization, the development of standardized design packages for different farm sizes and energy needs would be easier to implement. The packages would provide comprehensive technical specifications, installation guidelines, and maintenance schedules to help local technicians.

Policy advocacy should focus on obtaining government subsidies or low-interest loans in order to overcome the upfront capital cost barrier that is presently deterring small-scale farmer adoption. Demonstration projects showcasing the economic and environmental benefits could help build momentum for such policy changes.

Research should explore the inclusion of other renewables, such as small-scale wind where geographically suitable, to create more diversified hybrid systems. Ancillary research could examine the utilization of alternative feedstock for the production of biogas when there is a deficit in the availability of cattle manure.

Finally, the establishment of local service centers manned by trained technicians would address the current issue of maintenance expertise in rural areas. These centers could offer regular system check-ups, emergency repairs, and operator training programs to ensure long-term system performance and user confidence in the technology.

The successful implementation of these recommendations would enhance the system's performance, reduce costs, and accelerate adoption, ultimately contributing to sustainable rural electrification and agricultural development in Bangladesh and similar regions worldwide.

REFERENCES

1. References Ahmed, S., et al. (2020). Solar energy potential in rural Bangladesh. *Journal of Renewable Energy*, 45(3), 123–135.
2. Alam, M., & Hossain, M. (2019). Renewable energy policies in Bangladesh: Challenges and opportunities. *Energy Policy*, 120, 456–465.
3. Ali, M., et al. (2021). Economic potential of hybrid energy systems in rural areas. *Renewable and Sustainable Energy Reviews*, 145, 111–123.
4. Bader, M., et al. (2022). Viability of hybrid energy systems in remote areas. *Energy Conversion and Management*, 250, 345–356.
5. Hashimoto, Y., & Tezuka, T. (2018). Gasification of food wastes on a fluidized bed gasifier: Generation of synthesis gas and their relevant applications. *Energy Conversion and Management*, 165, 345–356.
6. Hossain, M. (2015). Hybrid solar PV-biogas-diesel power systems for off-grid applications. *Renewable Energy*, 80, 456–465.
7. Islam, M. R., et al. (2018). Agricultural waste for biogas production and electricity generation in agro-industrial systems. *Renewable Energy*, 120, 456–465.
8. Kabir, H., et al. (2018). Biogas systems for rural electrification: A case study in Bangladesh. *Energy for Sustainable Development*, 45, 78–89.
9. Kasaeian, A., et al. (2019). Design and optimization of hybrid energy systems for stand-alone applications. *Energy*, 180, 567–578.
10. Khalil, M. (2017). Biogas production from cattle waste: A comprehensive analysis. *Journal of Clean Energy Technologies*, 5(2), 89–97.
11. Kumar, R., et al. (2020). Optimization of hybrid energy systems for rural interconnections. *Renewable Energy*, 150, 345–356.
12. Lata-García, J., et al. (2024). A review of the energy economic feasibility of hybrid energy systems including energy storage and system optimization. *Renewable and Sustainable Energy Reviews*, 156, 111–123.
13. Mandal, S., et al. (2017). The potential of distributed solar PV and biogas technologies in off-grid areas of Bangladesh. *Renewable Energy*, 110, 456–465.
14. Mostafiz, R., et al. (2015). Energy challenges in rural Bangladesh: A case study of agro-dairy farms. *Energy Policy*, 85, 345–356.
15. Nassereddine, M., et al. (1993). Stability of hybrid photovoltaic and biogas systems in rural areas. *Renewable Energy*, 10(4), 567–578.
16. Odoi-Yorke, F., et al. (2022). Hybrid solar PV-biogas systems for rural Ghana: Economic and environmental benefits. *Renewable and Sustainable Energy Reviews*, 156, 111–123.
17. Podder, A., et al. (2022). Feasibility of hybrid energy systems in remote areas: A case study. *Energy Conversion and Management*, 250, 345–356.

18. Rahman, M., et al. (2019). Financial and technical constraints for renewable energy deployment in rural Bangladesh. *Renewable Energy*, 140, 456–465.
19. Sanni, S., et al. (2021). Techno-economic feasibility of hybrid energy systems for rural electrification. *Renewable Energy*, 170, 345–356.
20. SREDA. (2021). Hybrid energy systems for rural electrification in Bangladesh. Sustainable and Renewable Energy Development Authority.
21. Timothy, J., et al. (2020). Optimization of hybrid solar PV-biogas-diesel systems for rural electrification. *Renewable Energy*, 150, 345–356.
22. Zahid, M., et al. (2018). Socio-economic potential of solar and biogas systems in rural areas. *Energy for Sustainable Development*, 45, 78–89.

APPENDIX A

TURNITIN REPORT

211-33-1374

ORIGINALITY REPORT

9% SIMILARITY INDEX	8% INTERNET SOURCES	5% PUBLICATIONS	3% STUDENT PAPERS
-------------------------------	-------------------------------	---------------------------	-----------------------------

PRIMARY SOURCES

1	dspace.daffodilvarsity.edu.bd:8080 Internet Source	5%
2	research.library.mun.ca Internet Source	<1%
3	Mukesh Kumar Awasthi, Ashwani Kumar, Nitesh Dutt, Sivasakthivel Thangavel. "Heat Exchanger Technologies for Sustainable Renewable Energy Systems", CRC Press, 2025 Publication	<1%
4	ebin.pub Internet Source	<1%
5	www.degruyter.com Internet Source	<1%
6	www.mdpi.com Internet Source	<1%
7	www.researchgate.net Internet Source	<1%
8	P. Balamurugan. "Optimal scheduling and operation of hybrid biomass/wind/PV energy system for rural areas", International Journal of Energy Technology and Policy, 2009 Publication	<1%
9	minigrifafrica2017.rea.gov.ng Internet Source	<1%
10	Muhammad Shahzad Aziz, Umair Saleem, Ehsan Ali, Khalid Siddiq. "A review on bi-	<1%

APPENDIX B

**COMPLEX ENGINEERING PROBLEM SOLVING AND
ENGINEERING ACTIVITIES**

Complex Engineering Problems (P) Solving		
Complex Engineering Problems (P)	Attributes	Statement from Students
P1	Depth of knowledge required	The project required multidisciplinary knowledge in electrical, mechanical, and energy systems.
P2	Range of conflicting requirements	We balanced cost, sustainability, and reliability in system design.
P3	Depth of analysis required	Comprehensive simulations and economic analyses were conducted.
P4	Familiarity of issues	Issues like solar intermittency and biogas variability were addressed.
P5	Extent of applicable codes	International standards and simulation protocols were followed.
P6	Extent of stakeholder involvement and conflicting requirements	Stakeholder needs and energy policies were considered in the design.
P7	Interdependence	Energy sources were integrated to work together efficiently.

Complex Engineering Activities (A)		
Complex Engineering Activities (A)	Attributes	Statement from Students
A1	Range of resources	Multiple energy and computational resources were utilized.
A2	Level of interaction	System components interacted dynamically for stable output.
A3	Innovation	A hybrid design using local biogas input added innovation.
A4	Consequences of society and environment	The design aimed to reduce emissions and support rural development.
A5	Familiarity	The problem involved context-specific unfamiliar challenges.



Microgrid Proposal

PREPARED FOR:

Client Name, Client Title/Position
R7X5+538, Savar, Bangladesh

PREPARED BY:

Your Name, Your Title
Your Company Name, Your Email
Your Phone Number

This proposal was generated using HOMER Pro, a dynamic software engine that runs complex simulations of your hybrid electrical system's energy data and system components to determine the least-cost solution and most effective risk-mitigation strategies. Originally developed at the US Department of Energy's National Renewable Energy Laboratory (NREL), HOMER software set the global standard for optimizing microgrid design. More than 200,000 HOMER Pro users worldwide have produced economic feasibility studies, system design, engineering insight, and energy cost savings.

PREPARED BY:

Your Name,
Your Title, Your Company Name,
Your Email,
Your Phone Number



Table of Contents

Project Summary	3
About Your Company Name	4
Consumption Summary	5
Engineering Details	6
Cashflow Section.....	11
Glossary and Abbreviations	12
HOMER Energy Section	13
Extra time series charts	19
Extra time series charts	19
Extra time series charts	19
Extra time series charts	19
Extra time series charts	19
Extra time series charts	19

PREPARED BY:
Your Name,
Your Title, Your Company Name,
Your Email,
Your Phone Number



Project Summary

CURRENT SYSTEM + +

The electric needs of R7X5+538, Savar, Bangladesh are met with 5.0 kW of generator capacity and 7.9 kWh of battery capacity. Your operating costs for energy are currently \$1,252 per year.

PROPOSED SYSTEM + + +

We propose adding 5.9 kW of PV and 7.9 kWh of battery capacity. This would reduce your operating costs to \$934.68/yr. Your investment has a payback of 13.5 years and an IRR of 4.81%.

Simple payback:	13.5 yr	Net Present Value:	\$1,074
Return on Investment:	3.15 %	Capital Investment:	\$3,951
Internal Rate of Return:	4.81 %	Annualized Savings:	\$317.71

Cumulative Cash Flow over Project Lifetime

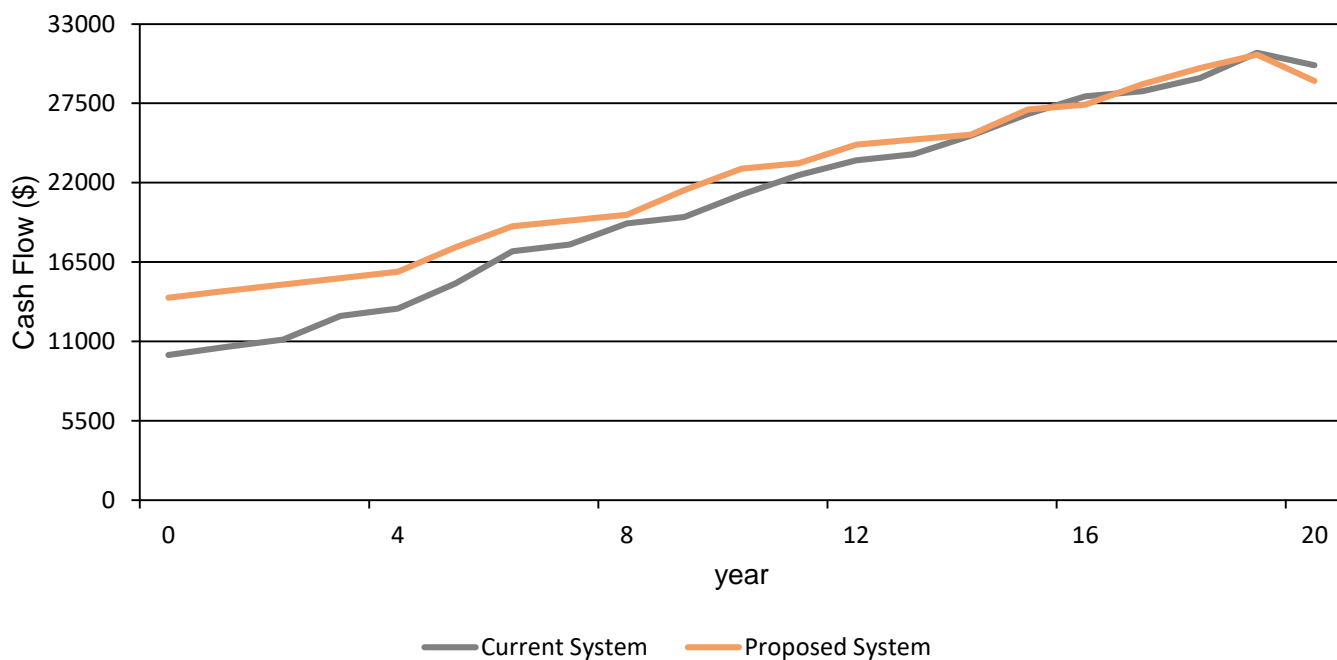

PREPARED BY:

Your Name,
 Your Title, Your Company Name,
 Your Email,
 Your Phone Number



Your Company Name

ABOUT YOUR COMPANY NAME

Use this section to introduce your company name and explain what your business does, where you operate (or the markets you serve), and how long you've been doing it for.

About Us page is the ideal place to accommodate several objectives:

- Communicate the story of your business and why you started it.
- Describe the customers or the cause that your business serves.
- Explain your business model or how your products are made

Customer Testimonials

Use this space to provide statements made about your company by satisfied customers. Quotes and positive comments are valuable to prospective clients as they evaluate their options and decide whether your company's services provide the best solution to fit their needs. Testimonial statements demonstrate how others have benefited from your company's services, making them a powerful tool for establishing trust and encouraging potential clients to take action.

—John J. Client, CEO - Your Happy Client, Inc.

PREPARED BY:

Your Name,
Your Title, Your Company Name,
Your Email,
Your Phone Number



HOMER
Pro

Consumption Summary

Electric Consumption

This microgrid requires 28 kWh/day and has a peak of 3.812 kW. In the proposed system, the following generation sources serve the electrical load.

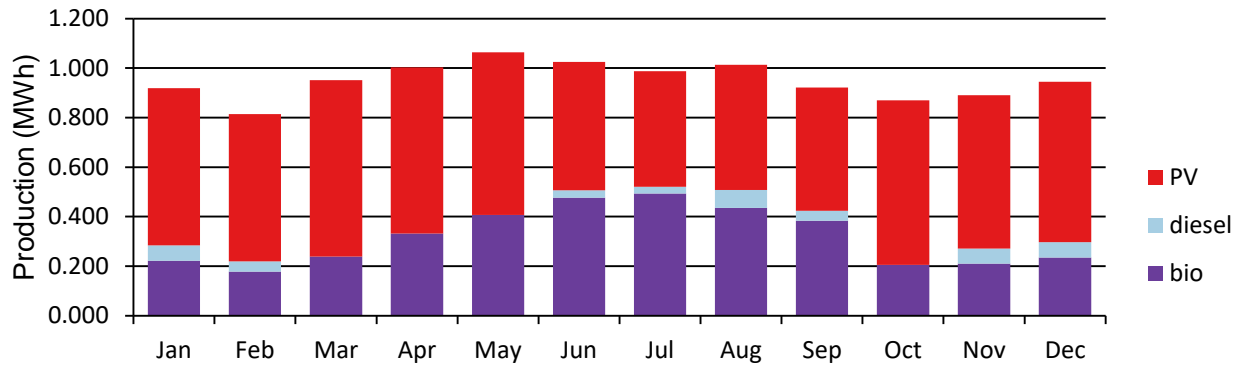

PREPARED BY:
Your Name,
Your Title, Your Company Name,
Your Email,
Your Phone Number



Engineering Details

PV: Generic flat plate PV

The Generic PV system has a nominal capacity of 5.88 kW. The annual production is 7,193 kWh/yr.

Rated Capacity	5.88 kW	Total Production	7,193 kWh
Capital Cost	\$2,951	Maintenance Cost	29.8 \$/yr
Specific Yield	1,223 kWh/kW	LCOE	0.0284 \$/kWh
PV Penetration	70.1 %	DC-AC Ratio	1.96

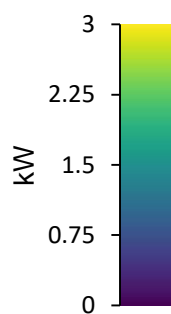
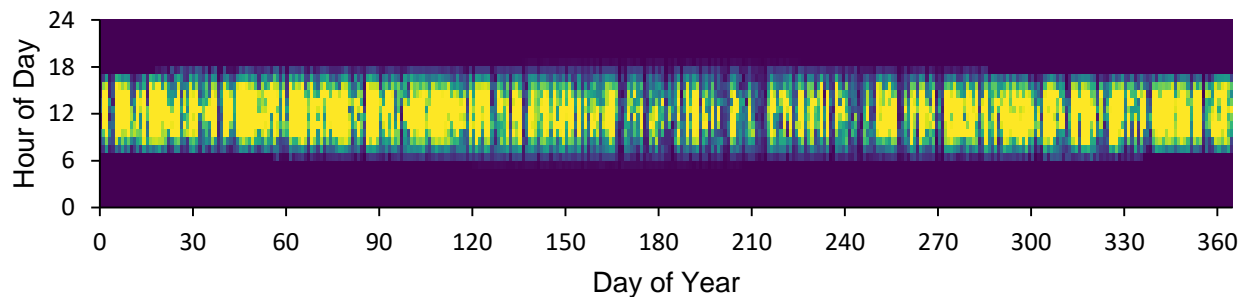

Generator: Generic Small Genset (size-your-own) (Diesel)

Power output from the Generic generator system, rated at 2.00 kW using Diesel as fuel, is 397 kWh/yr.

Capacity	2.00 kW	Generator Fuel	Diesel
Operational Life	18.9 yr	Generator Fuel Price	0.860 \$/L
Capital Cost	\$1,250	Maintenance Cost	79.2 \$/yr
Fuel Consumption	118 L	Electrical Production	397 kWh/yr
Hours of Operation	792 hrs/yr	Marginal Generation Cost	0.286 \$/kWh
Fixed Generation Cost	0.149 \$/hr		

PREPARED BY:

Your Name,
Your Title, Your Company Name,
Your Email,
Your Phone Number



Engineering Details

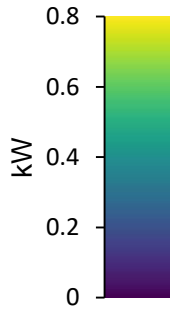
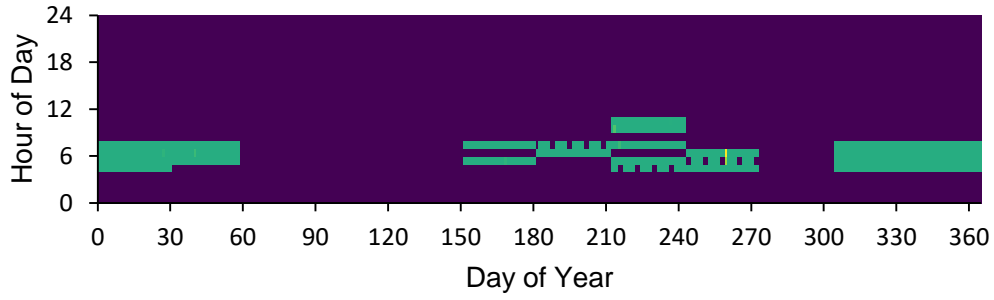

PREPARED BY:
Your Name,
Your Title, Your Company Name,
Your Email,
Your Phone Number



Engineering Details

Generator: Generic Small Genset (size-your-own) (1) (Biogas)

Power output from the Generic generator system, rated at 3.00 kW using Biogas as fuel, is 3,817 kWh/yr.

Capacity	3.00 kW
Operational Life	5.74 yr
Capital Cost	\$1,620
Fuel Consumption	7.89 tons/yr
Hours of Operation	2,611 hrs/yr
Fixed Generation Cost	0.0981 \$/hr

Generator Fuel	Biogas
Generator Fuel Price	0.0400 \$/kg
Maintenance Cost	47.0 \$/yr
Electrical Production	3,817 kWh/yr
Marginal Generation Cost	0.000184 \$/kWh

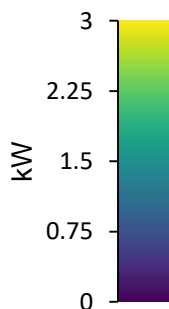
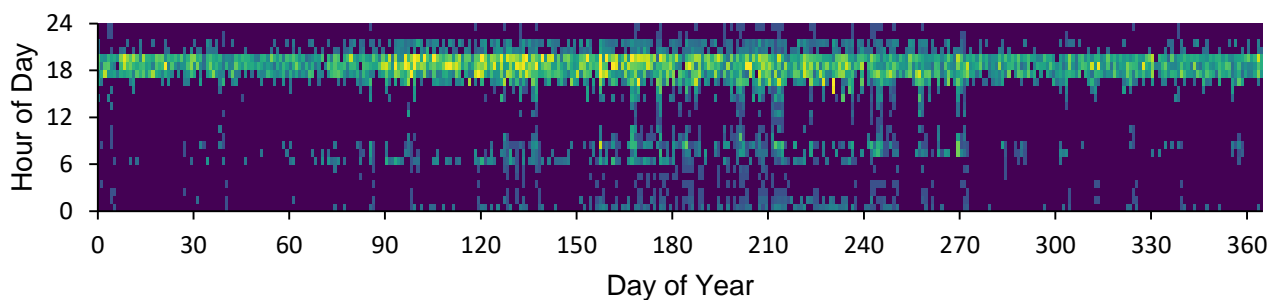

Storage: BAE SUNDEPOT 24-420

The BAE Batterien GmbH storage system's nominal capacity is 15.7 kWh. The annual throughput is 2,105 kWh/yr.

Rated Capacity	15.7 kWh
Annual Throughput	2,105 kWh/yr
Maintenance Cost	0.400 \$/yr
Autonomy	10.7 hr

Expected Life	8.30 yr
Capital Costs	\$2,000
Losses	108 kWh/yr

PREPARED BY:

Your Name,
 Your Title, Your Company Name,
 Your Email,
 Your Phone Number



Engineering Details

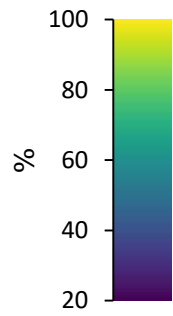
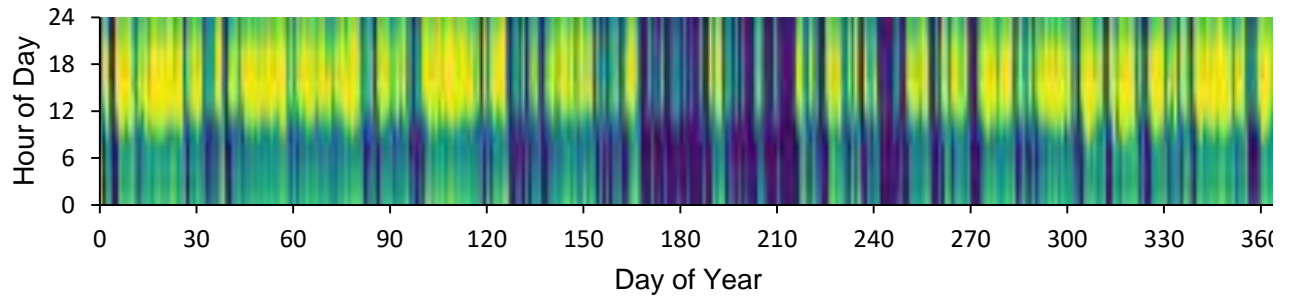

PREPARED BY:
Your Name,
Your Title, Your Company Name,
Your Email,
Your Phone Number



Engineering Details

Converter: Pika Grid-Tie Hybrid X3001

Capacity	3.00 kW
Mean Output	0.700 kW
Minimum Output	0 kW
Maximum Output	2.48 kW
Capacity Factor	23.3 %

Hours of Operation	7,136 hrs/yr
Energy Out	6,133 kWh/yr
Energy In	6,388 kWh/yr
Losses	256 kWh/yr

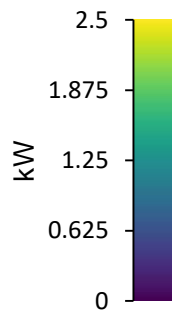
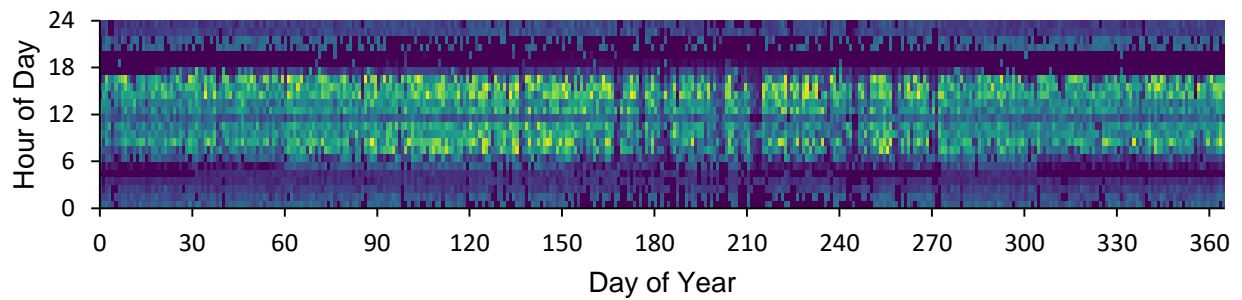

PREPARED BY:
Your Name,
Your Title, Your Company Name,
Your Email,
Your Phone Number



Cash Flows

Project Lifetime 20 years

Expected Inflation Rate 6.5%

Nominal Discount Rate 9.0%

Real Interest Rate 2.3%

Year	1	2	3	4	5	6	7	8	9	10
BAE SUNDEPOT 24-420	(\$0.400)	(\$0.400)	(\$0.400)	(\$0.400)	(\$0.400)	(\$0.400)	(\$0.400)	(\$0.400)	(\$0.400)	(\$0.400)
Generic flat plate PV	(\$9.80)	(\$9.80)	(\$9.80)	(\$9.80)	(\$9.80)	(\$9.80)	(\$9.80)	(\$9.80)	(\$9.80)	(\$9.80)
Generic Small Genset (size-your-own)	(\$79.20)	(\$79.20)	(\$79.20)	(\$79.20)	(\$79.20)	(\$79.20)	(\$79.20)	(\$79.20)	(\$79.20)	(\$79.20)
Generic Small Genset (size-your-own) (1)	(\$47.00)	(\$47.00)	(\$47.00)	(\$47.00)	(\$47.00)	(\$47.00)	(\$47.00)	(\$47.00)	(\$47.00)	(\$47.00)
HOMER Load Following	(\$30.00)	(\$30.00)	(\$30.00)	(\$30.00)	(\$30.00)	(\$30.00)	(\$30.00)	(\$30.00)	(\$30.00)	(\$30.00)
Other	(\$100.00)	(\$100.00)	(\$100.00)	(\$100.00)	(\$100.00)	(\$100.00)	(\$100.00)	(\$100.00)	(\$100.00)	(\$100.00)
Pika Grid-Tie Hybrid X3001	(\$90.00)	(\$90.00)	(\$90.00)	(\$90.00)	(\$90.00)	(\$90.00)	(\$90.00)	(\$90.00)	(\$90.00)	(\$90.00)
PV Dedicated Converter	(\$20.00)	(\$20.00)	(\$20.00)	(\$20.00)	(\$20.00)	(\$20.00)	(\$20.00)	(\$20.00)	(\$20.00)	(\$20.00)

Year	11	12	13	14	15	16	17	18	19	20
BAE SUNDEPOT 24-420	(\$0.400)	(\$0.400)	(\$0.400)	(\$0.400)	(\$0.400)	(\$0.400)	(\$0.400)	(\$0.400)	(\$0.400)	(\$0.400)
Generic flat plate PV	(\$9.80)	(\$9.80)	(\$9.80)	(\$9.80)	(\$9.80)	(\$9.80)	(\$9.80)	(\$9.80)	(\$9.80)	(\$9.80)
Generic Small Genset (size-your-own)	(\$79.20)	(\$79.20)	(\$79.20)	(\$79.20)	(\$79.20)	(\$79.20)	(\$79.20)	(\$79.20)	(\$79.20)	(\$79.20)
Generic Small Genset (size-your-own) (1)	(\$47.00)	(\$47.00)	(\$47.00)	(\$47.00)	(\$47.00)	(\$47.00)	(\$47.00)	(\$47.00)	(\$47.00)	(\$47.00)
HOMER Load Following	(\$30.00)	(\$30.00)	(\$30.00)	(\$30.00)	(\$30.00)	(\$30.00)	(\$30.00)	(\$30.00)	(\$30.00)	(\$30.00)
Other	(\$100.00)	(\$100.00)	(\$100.00)	(\$100.00)	(\$100.00)	(\$100.00)	(\$100.00)	(\$100.00)	(\$100.00)	(\$100.00)
Pika Grid-Tie Hybrid X3001	(\$90.00)	(\$90.00)	(\$90.00)	(\$90.00)	(\$90.00)	(\$90.00)	(\$90.00)	(\$90.00)	(\$90.00)	(\$90.00)
PV Dedicated Converter	(\$20.00)	(\$20.00)	(\$20.00)	(\$20.00)	(\$20.00)	(\$20.00)	(\$20.00)	(\$20.00)	(\$20.00)	(\$20.00)

Year
BAE SUNDEPOT 24-420
Generic flat plate PV
Generic Small Genset (size-your-own)
Generic Small Genset (size-your-own) (1)
HOMER Load Following
Other
Pika Grid-Tie Hybrid X3001
PV Dedicated Converter

PREPARED BY:
Your Name,
 Your Title, Your Company Name,
 Your Email,
 Your Phone Number



Glossary and Abbreviations

Net Present Value

The total net present cost (NPC) of a system is the present value of all the costs the system incurs over its lifetime, minus the present value of all the revenue it earns over its lifetime. Costs include capital costs, replacement costs, O & M costs, fuel costs, emissions penalties, and the costs of buying power from the grid. Revenues include salvage value and grid sales revenue. HOMER calculates the total NPC by summing the total discounted cash flows in each year of the project lifetime.

Total Annualized Cost

- is the annualized value of the total net present cost. The annualized cost of a component is the cost that, if it were to occur equally in every year of the project lifetime, would give the same net present cost as the actual cash flow sequence associated with that component. HOMER calculates annualized cost by first calculating the net present cost, then multiplying it by the capital recovery factor.

Simple payback

- is the number of years at which the cumulative cash flow of the difference between the current system and base case system switches from negative to positive. The payback is an indication of how long it would take to recover the difference in investment costs between the current system and the base case system.

Return on Investment (ROI)

- is the yearly cost savings relative to the initial investment. The ROI is the average yearly difference in nominal cash flows over the project lifetime, divided by the difference in capital cost.

Internal rate of return (IRR)

- is the discount rate at which the base case and current system have the same net present cost. HOMER calculates the IRR by determining the discount rate that makes the present value of the difference of the two cash flow sequences equal to zero.

Refer to HOMER Pro Online Help Manual

Abbreviations

diesel	Generic Small Genset (size-your-own)
bio	Generic Small Genset (size-your-own) (1)
BAE	BAE SUNDEPOT 24-420
SUNDEPOT 24-420	
PV	Generic flat plate PV
PikaX3001	Pika Grid-Tie Hybrid X3001

PREPARED BY:

Your Name,
Your Title, Your Company Name,
Your Email,
Your Phone Number



About HOMER Pro

HOMER® Pro simulates engineering and economic feasibility of microgrid or distributed energy systems that are off-grid or tied to an unreliable grid and enables the design of least-cost electrical systems and risk-mitigation strategies. The software provides insight into cost-effectively combining conventional and renewable energy, storage, grid resources (where available), and load management.

In a single data run, HOMER Pro simulates the operation of a hybrid microgrid or distributed energy system for an entire year, evaluating and optimizing the electrical system design, load profiles, components, fuel costs, and environmental variables. The simulation produces key information on technical performance, risk-mitigation, and projected cost-savings to inform system design and optimization. Results are presented in a succinct Microgrid Proposal. For more information, visit HomerEnergy.com.

About HOMER Energy by UL



HOMER software is used by more than 200,000 users in 193 different countries.

HOMER Energy by UL is the developer and distributor of HOMER software, a global standard for energy modeling tools that analyze solar-plus-storage, microgrids, and other distributed energy projects.

HOMER software helps engineers and project developers navigate the complexities of designing cost-effective and reliable microgrids that combine traditional and renewable generation sources. The company makes two software platforms: HOMER Pro for the design of least-cost hybrid microgrid or distributed energy systems for use off-grid or when tied to an unreliable grid; and HOMER Grid, which helps design behind-the-meter solar-plus-storage systems to reduce costs and lower carbon footprints.

Since its founding in Boulder, Colorado in 2009, HOMER Energy software has proven effective for analyzing complex distributed energy systems, including grid-tied hybrid renewable microgrids and situations where the grid is insufficiently reliable, such as islands and remote communities. In 2019, HOMER Energy was acquired by UL. More than 200,000 HOMER Pro users in over 190 countries have produced economic feasibility studies, system design, engineering insight, and energy cost savings. Learn more at www.homerenergy.com.

PREPARED BY:

Your Name,
Your Title, Your Company Name,
Your Email,
Your Phone Number



Time series charts:

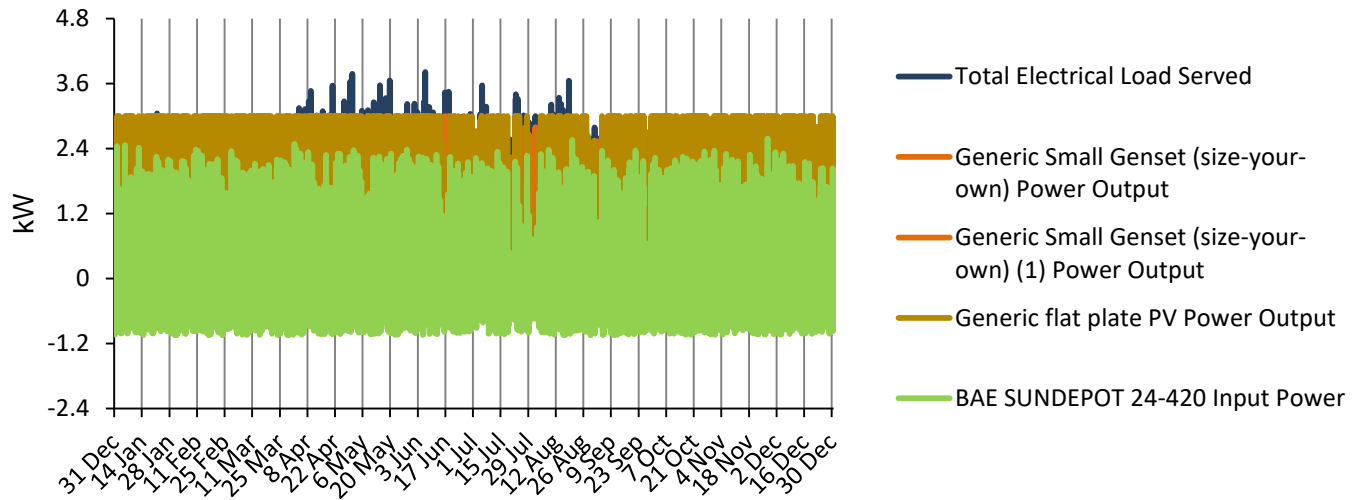

PREPARED BY:

Your Name,
Your Title, Your Company Name,
Your Email,
Your Phone Number



Time series charts:

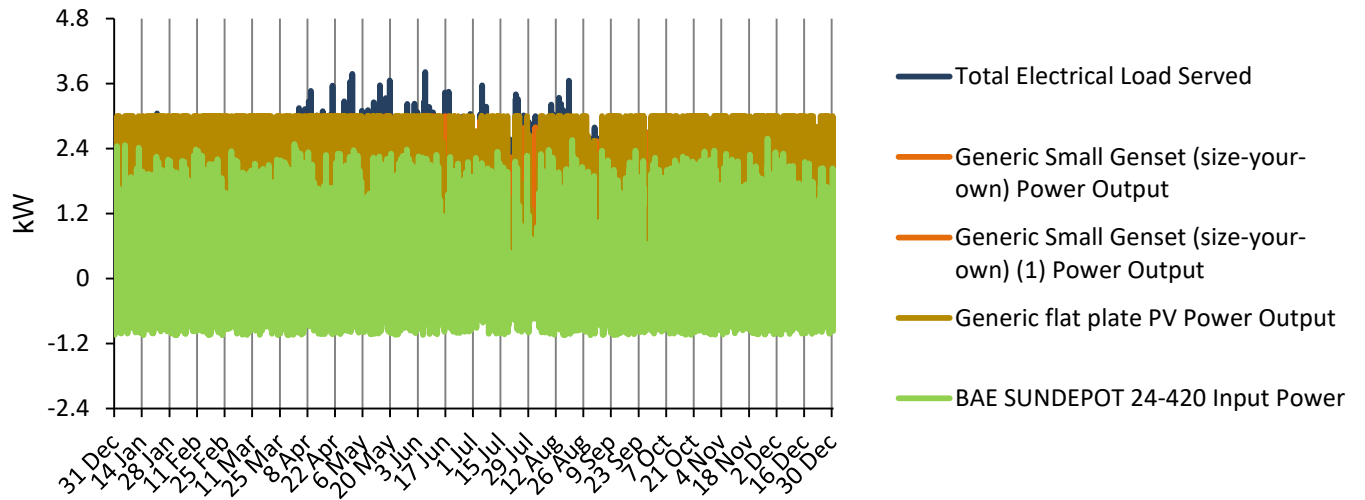

PREPARED BY:
Your Name,
Your Title, Your Company Name,
Your Email,
Your Phone Number



Time series charts:

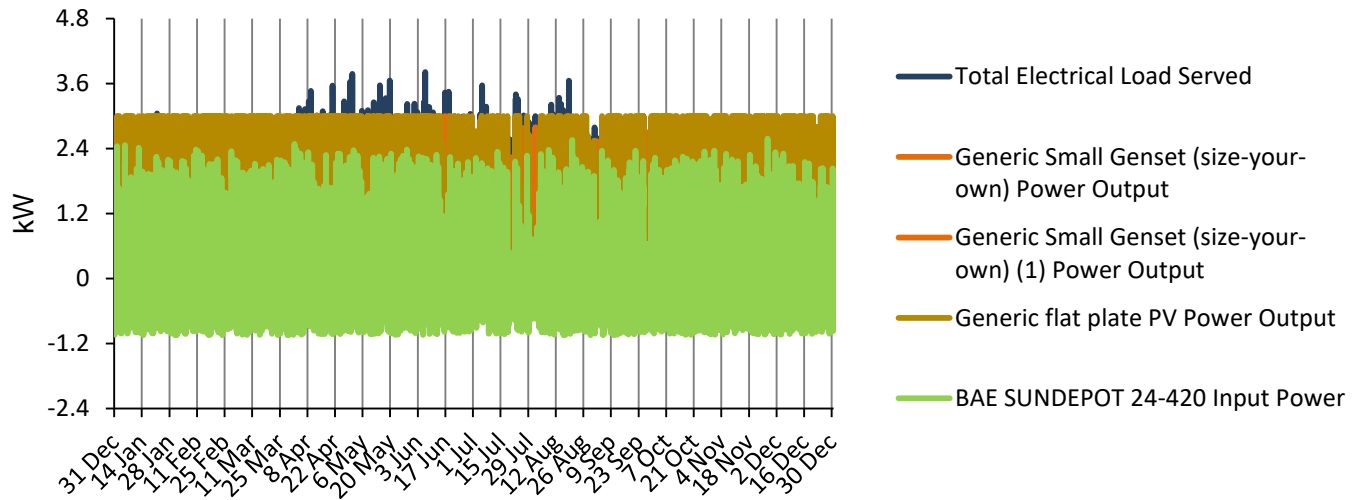

PREPARED BY:
Your Name,
Your Title, Your Company Name,
Your Email,
Your Phone Number



Time series charts:

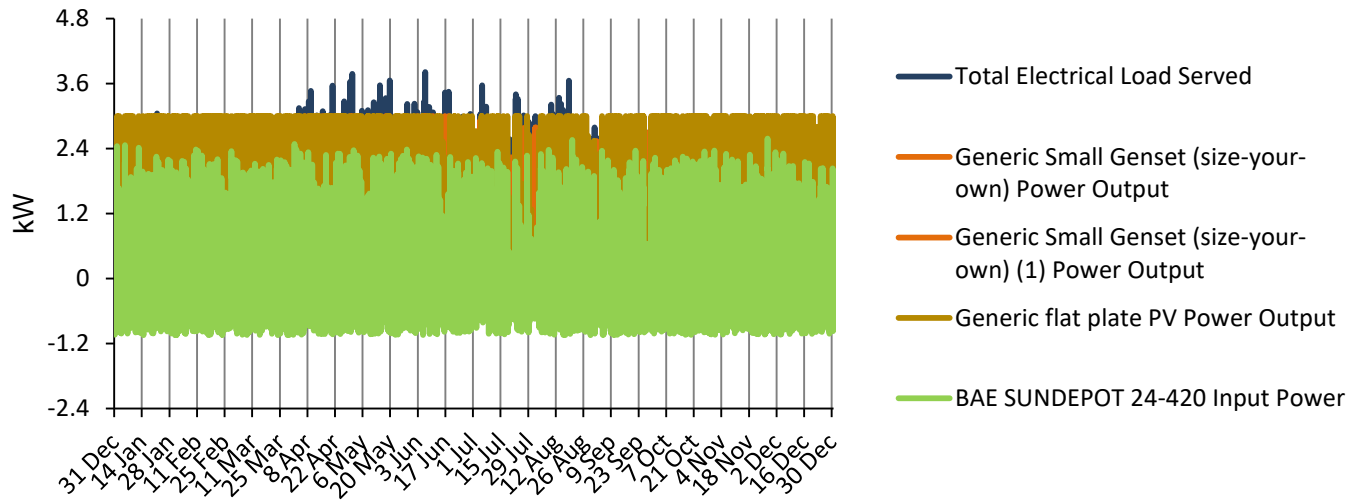

PREPARED BY:
Your Name,
Your Title, Your Company Name,
Your Email,
Your Phone Number



Time series charts:

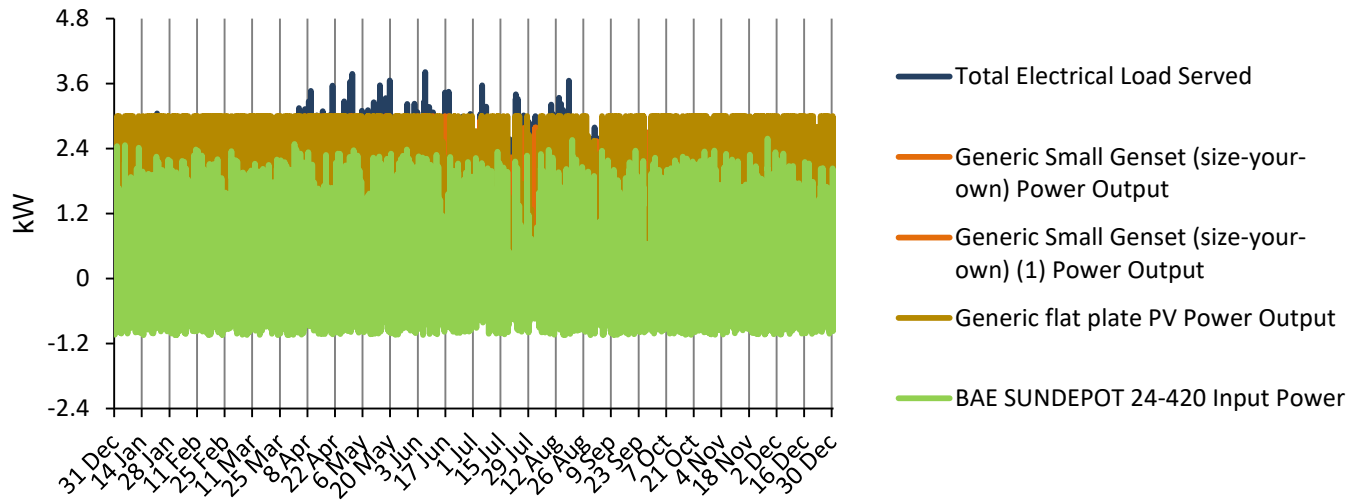

PREPARED BY:
Your Name,
Your Title, Your Company Name,
Your Email,
Your Phone Number



Time series charts:

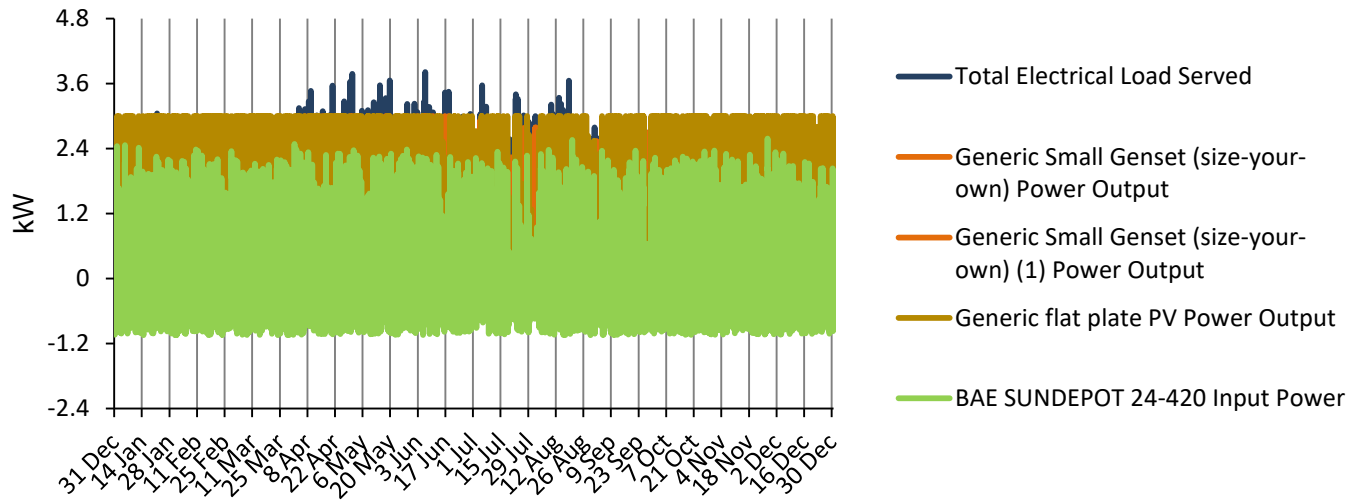

PREPARED BY:
Your Name,
Your Title, Your Company Name,
Your Email,
Your Phone Number





System Simulation Report



File:

Author:

Location: R7X5+538, Savar, Bangladesh (23°50.9'N, 90°15.5'E)

Total Net Present Cost: \$28,804.38

Levelized Cost of Energy (\$/kWh): \$0.177

Notes: hydrid (solar,biogas and diesel) sytem for savar

Table of Contents

System Architecture	3
Cost Summary	4
Cash Flow	6
Electrical Summary	7
Generator: Generic Small Genset (size-your-own) (Diesel)	8
Generator: Generic Small Genset (size-your-own) (1) (Biogas)	9
PV: Generic flat plate PV	10
Storage: BAE SUNDEPOT 24-420	11
Converter: Pika Grid-Tie Hybrid X3001	12
Fuel Summary	13
Renewable Summary	15
Compare Economics	16
Time series charts:	18
Time series charts:	19
Time series charts:	20
Time series charts:	21
Time series charts:	22
Time series charts:	23

System Architecture

Component	Name	Size	Unit
Generator #1	Generic Small Genset (size-your-own)	2.00	kW
Generator #2	Generic Small Genset (size-your-own) (1)	3.00	kW
PV	Generic flat plate PV	5.88	kW
PV dedicated converter	PV converter	3.00	kW
Storage	BAE SUNDEPOT 24-420	2	strings
System converter	Pika Grid-Tie Hybrid X3001	3.00	kW
Dispatch strategy	HOMER Load Following		

Schematic

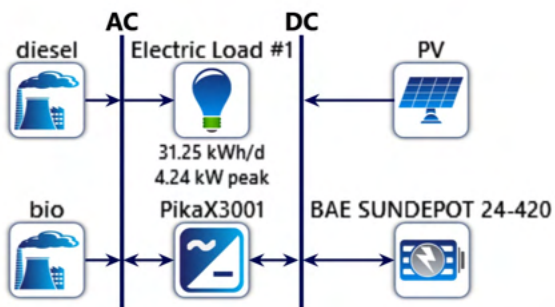

Cost Summary

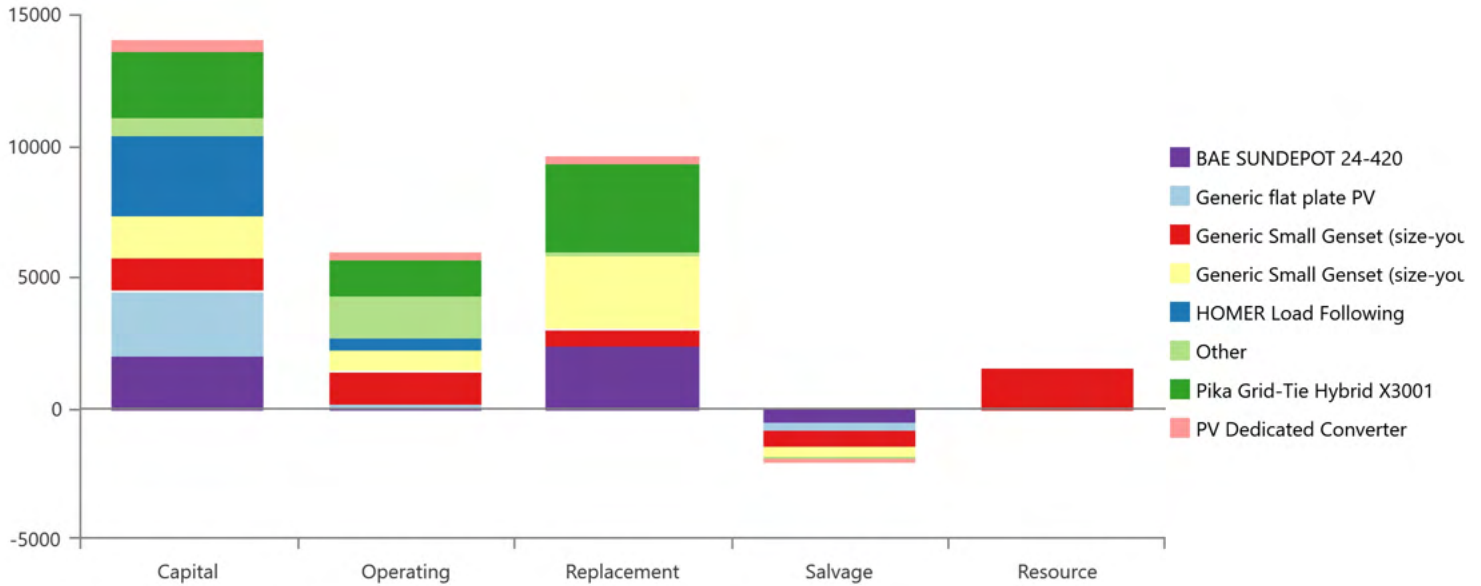

Net Present Costs

Name	Capital	Operating	Replacement	Salvage	Resource	Total
BAE SUNDEPOT 24-420	\$2,000	\$6.33	\$2,408	-\$593.41	\$0.00	\$3,821
Generic flat plate PV	\$2,451	\$155.08	\$0.00	-\$308.23	\$0.00	\$2,298
Generic Small Genset (size-your-own)	\$1,250	\$1,253	\$612.17	-\$563.84	\$1,611	\$4,162
Generic Small Genset (size-your-own) (1)	\$1,620	\$743.33	\$2,774	-\$391.32	\$14.97	\$4,761
HOMER Load Following	\$3,000	\$474.49	\$0.00	\$0.00	\$0.00	\$3,474
Other	\$700.00	\$1,582	\$141.21	-\$83.83	\$0.00	\$2,339
Pika Grid-Tie Hybrid X3001	\$2,500	\$1,423	\$3,345	\$0.00	\$0.00	\$7,269
PV Dedicated Converter	\$500.00	\$316.32	\$282.43	-\$167.66	\$0.00	\$931.09
System	\$14,021	\$5,953	\$9,563	-\$2,108	\$1,626	\$29,056



Annualized Costs

Name	Capital	Operating	Replacement	Salvage	Resource	Total
BAE SUNDEPOT 24-420	\$126.45	\$0.400	\$152.27	-\$37.52	\$0.00	\$241.61
Generic flat plate PV	\$154.98	\$9.80	\$0.00	-\$19.49	\$0.00	\$145.30
Generic Small Genset (size-your-own)	\$79.03	\$79.20	\$38.71	-\$35.65	\$101.88	\$263.17
Generic Small Genset (size-your-own) (1)	\$102.43	\$47.00	\$175.38	-\$24.74	\$0.947	\$301.01
HOMER Load Following	\$189.68	\$30.00	\$0.00	\$0.00	\$0.00	\$219.68
Other	\$44.26	\$100.00	\$8.93	-\$5.30	\$0.00	\$147.89
Pika Grid-Tie Hybrid X3001	\$158.07	\$90.00	\$211.51	\$0.00	\$0.00	\$459.57
PV Dedicated Converter	\$31.61	\$20.00	\$17.86	-\$10.60	\$0.00	\$58.87
System	\$886.51	\$376.40	\$604.65	-\$133.30	\$102.83	\$1,837



Cash Flow

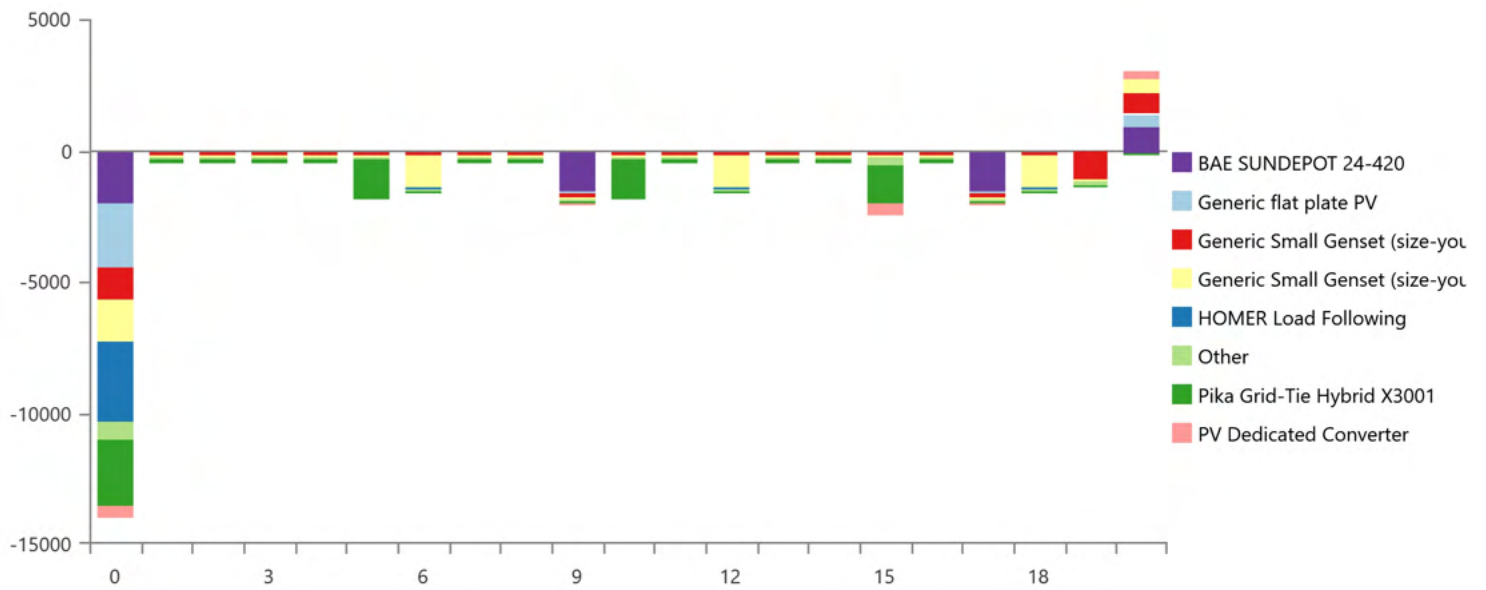
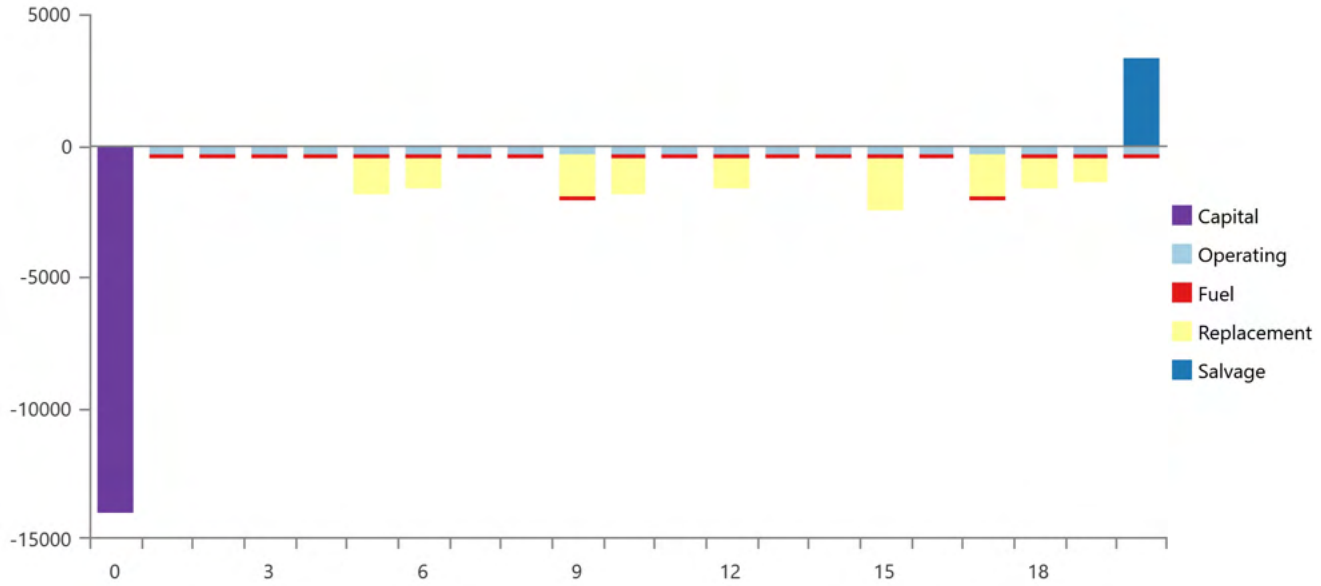



Electrical Summary

Excess and Unmet

Quantity	Value	Units
Excess Electricity	1,743	kWh/yr
Unmet Electric Load	0	kWh/yr
Capacity Shortage	0	kWh/yr

Production Summary

Component	Production (kWh/yr)	Percent
Generic flat plate PV	7,193	63.1
Generic Small Genset (size-your-own)	397	3.48
Generic Small Genset (size-your-own) (1)	3,817	33.5
Total	11,407	100

Consumption Summary

Component	Consumption (kWh/yr)	Percent
AC Primary Load	10,266	100
DC Primary Load	0	0
Deferrable Load	0	0
Total	10,266	100

Generator: Generic Small Genset (size-your-own) (Diesel)

Generic Small Genset (size-your-own) Electrical Summary

Quantity	Value	Units
Electrical Production	397	kWh/yr
Mean Electrical Output	0.501	kW
Minimum Electrical Output	0.500	kW
Maximum Electrical Output	0.798	kW

Generic Small Genset (size-your-own) Fuel Summary

Quantity	Value	Units
Fuel Consumption	118	L
Specific Fuel Consumption	0.299	L/kWh
Fuel Energy Input	1,166	kWh/yr
Mean Electrical Efficiency	34.0	%

Generic Small Genset (size-your-own) Statistics

Quantity	Value	Units
Hours of Operation	792	hrs/yr
Number of Starts	344	starts/yr
Operational Life	18.9	yr
Capacity Factor	2.26	%
Fixed Generation Cost	0.149	\$/hr
Marginal Generation Cost	0.286	\$/kWh

Generic Small Genset (size-your-own) Output (kW)

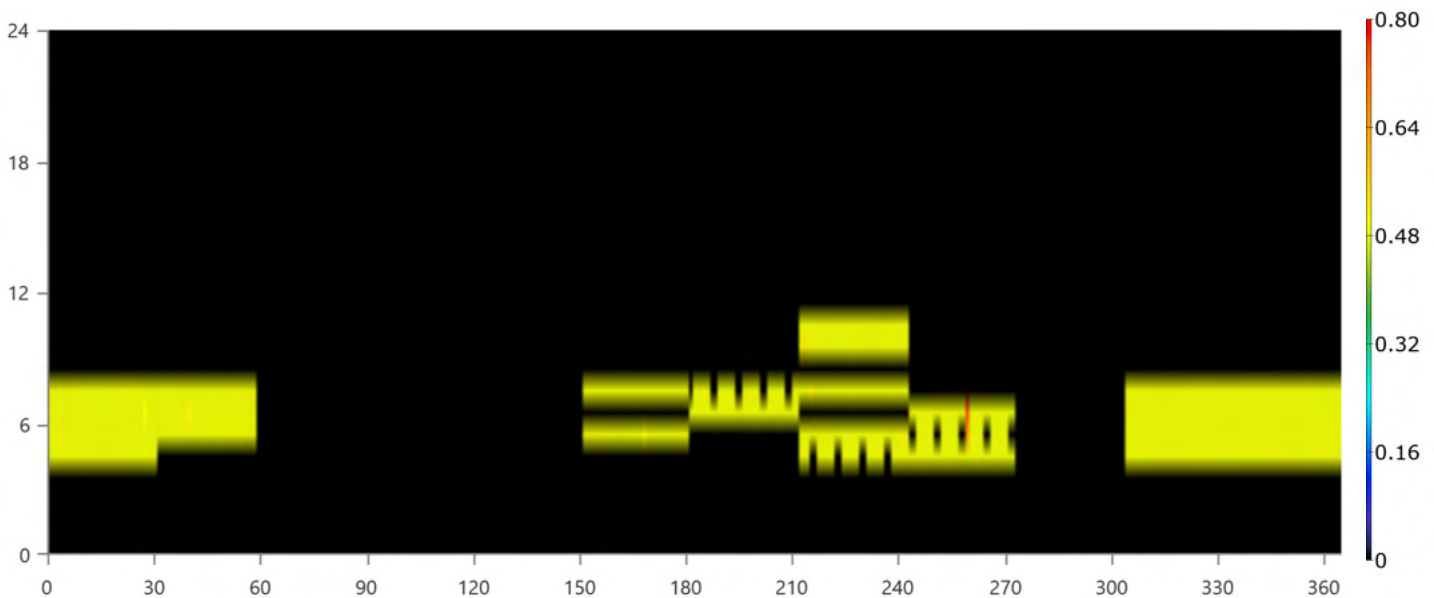

Generator: Generic Small Genset (size-your-own) (1) (Biogas)

Generic Small Genset (size-your-own) (1) Electrical Summary

Quantity	Value	Units
Electrical Production	3,817	kWh/yr
Mean Electrical Output	1.46	kW
Minimum Electrical Output	0.750	kW
Maximum Electrical Output	3.00	kW

Generic Small Genset (size-your-own) (1) Fuel Summary

Quantity	Value	Units
Fuel Consumption	7.89	tons/yr
Specific Fuel Consumption	1.96	kg/kWh
Fuel Energy Input	14,574	kWh/yr
Mean Electrical Efficiency	26.2	%

Generic Small Genset (size-your-own) (1) Statistics

Quantity	Value	Units
Hours of Operation	2,611	hrs/yr
Number of Starts	878	starts/yr
Operational Life	5.74	yr
Capacity Factor	14.5	%
Fixed Generation Cost	0.0981	\$/hr
Marginal Generation Cost	0.000184	\$/kWh

Generic Small Genset (size-your-own) (1) Output (kW)

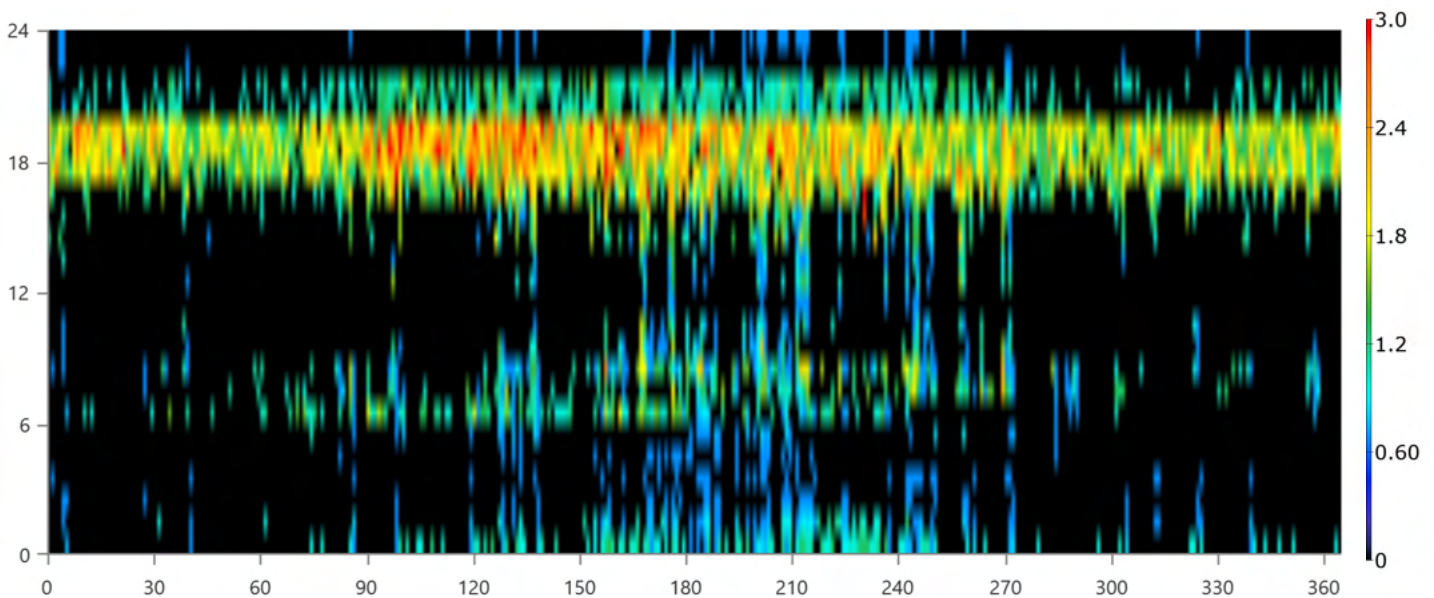

PV: Generic flat plate PV

Generic flat plate PV Electrical Summary

Quantity	Value	Units
Minimum Output	0	kW
Maximum Output	3.00	kW
PV Penetration	70.1	%
Hours of Operation	4,376	hrs/yr
Levelized Cost	0.0284	\$/kWh

Generic flat plate PV Statistics

Quantity	Value	Units
Rated Capacity	5.88	kW
Mean Output	0.821	kW
Mean Output	19.7	kWh/d
Capacity Factor	14.0	%
Total Production	7,193	kWh/yr
Dedicated converter	3.00	kW

Generic flat plate PV Output (kW)

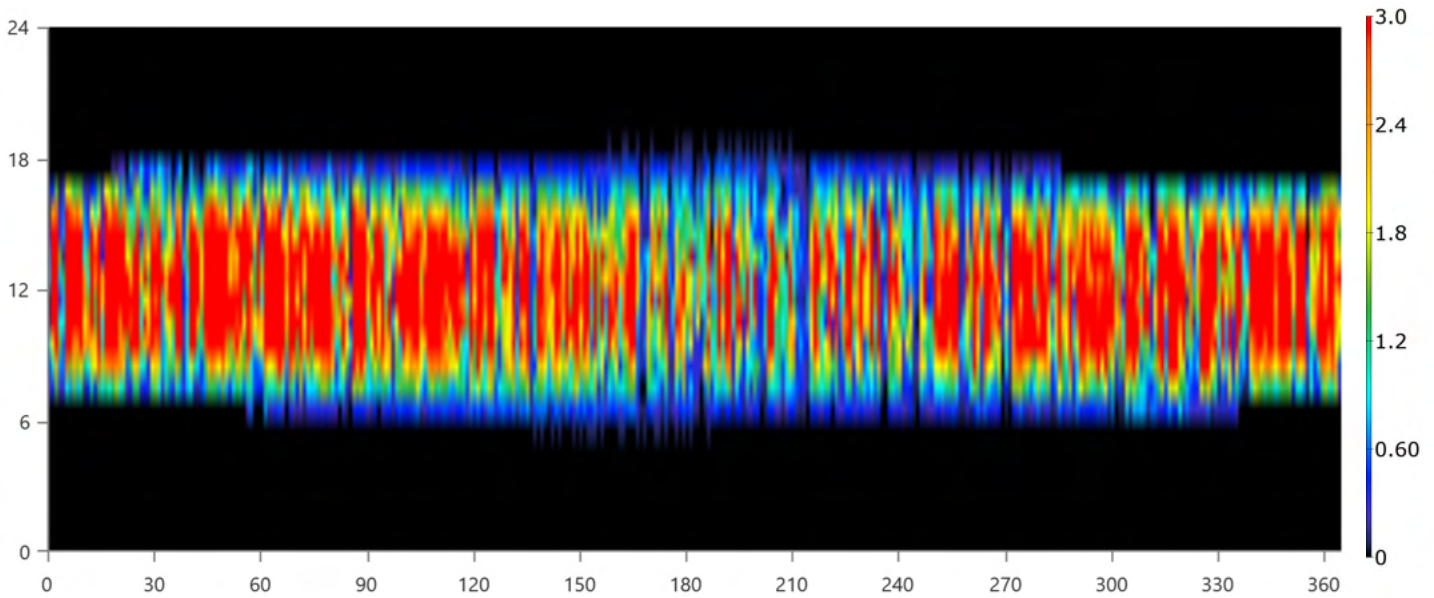

Storage: BAE SUNDEPOT 24-420

BAE SUNDEPOT 24-420 Properties

Quantity	Value	Units
Batteries	2.00	qty.
String Size	1.00	batteries
Strings in Parallel	2.00	strings
Bus Voltage	24.0	V

BAE SUNDEPOT 24-420 Result Data

Quantity	Value	Units
Average Energy Cost	0	\$/kWh
Energy In	2,156	kWh/yr
Energy Out	2,052	kWh/yr
Storage Depletion	4.44	kWh/yr
Losses	108	kWh/yr
Annual Throughput	2,105	kWh/yr

BAE SUNDEPOT 24-420 Statistics

Quantity	Value	Units
Autonomy	10.7	hr
Storage Wear Cost	0.0940	\$/kWh
Nominal Capacity	15.7	kWh
Usable Nominal Capacity	12.6	kWh
Lifetime Throughput	17,472	kWh
Expected Life	8.30	yr

BAE SUNDEPOT 24-420 State of Charge (%)

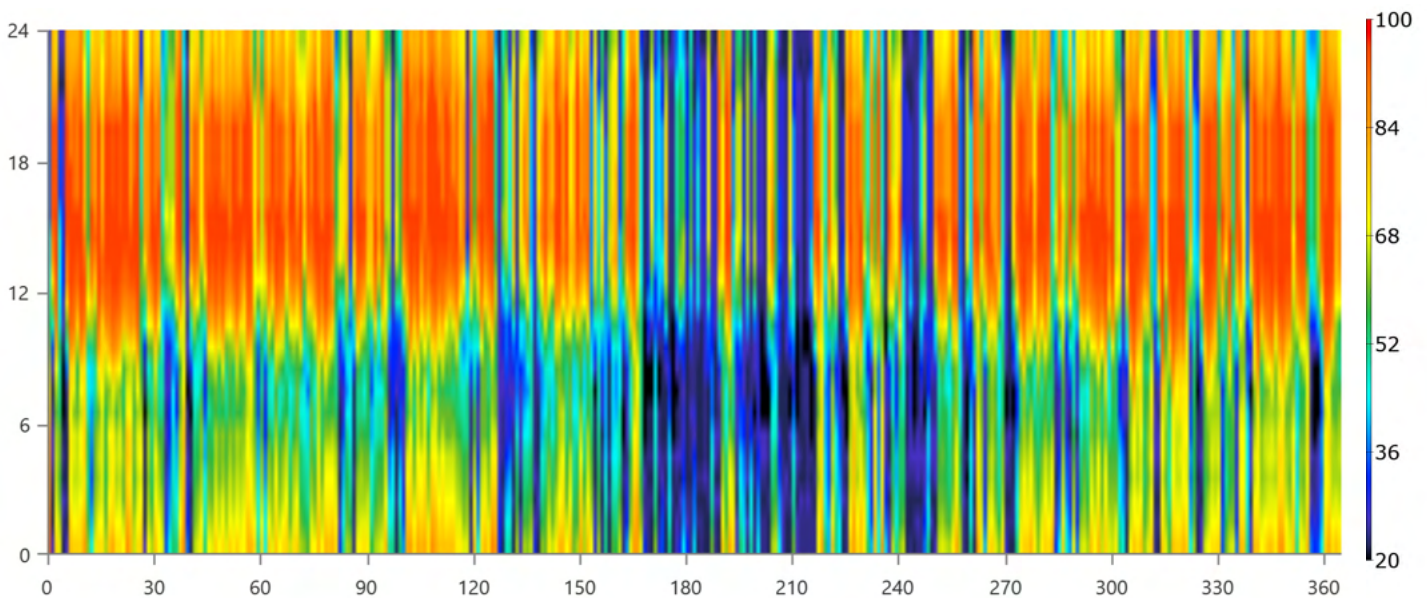

Converter: Pika Grid-Tie Hybrid X3001

Pika Grid-Tie Hybrid X3001 Electrical Summary

Quantity	Value	Units
Hours of Operation	7,136	hrs/yr
Energy Out	6,133	kWh/yr
Energy In	6,388	kWh/yr
Losses	256	kWh/yr

Pika Grid-Tie Hybrid X3001 Statistics

Quantity	Value	Units
Capacity	3.00	kW
Mean Output	0.700	kW
Minimum Output	0	kW
Maximum Output	2.48	kW
Capacity Factor	23.3	%

Pika Grid-Tie Hybrid X3001 Inverter Output (kW)

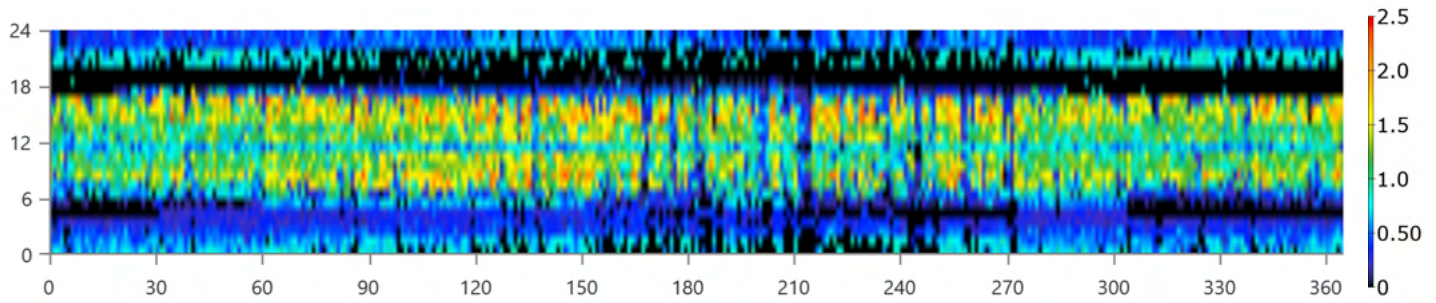

Pika Grid-Tie Hybrid X3001 Rectifier Output (kW)

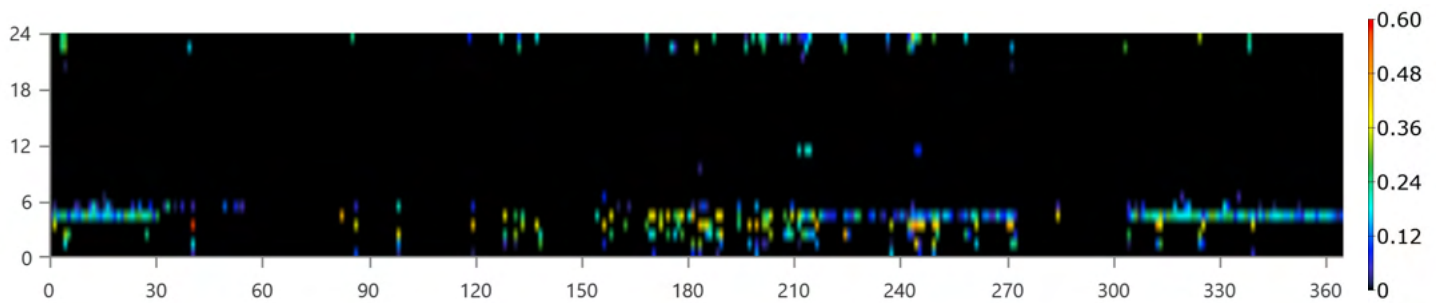

Fuel Summary

Diesel Consumption Statistics

Quantity	Value	Units
Total fuel consumed	118	L
Avg fuel per day	0.325	L/day
Avg fuel per hour	0.0135	L/hour

Diesel Consumption (L/hr)

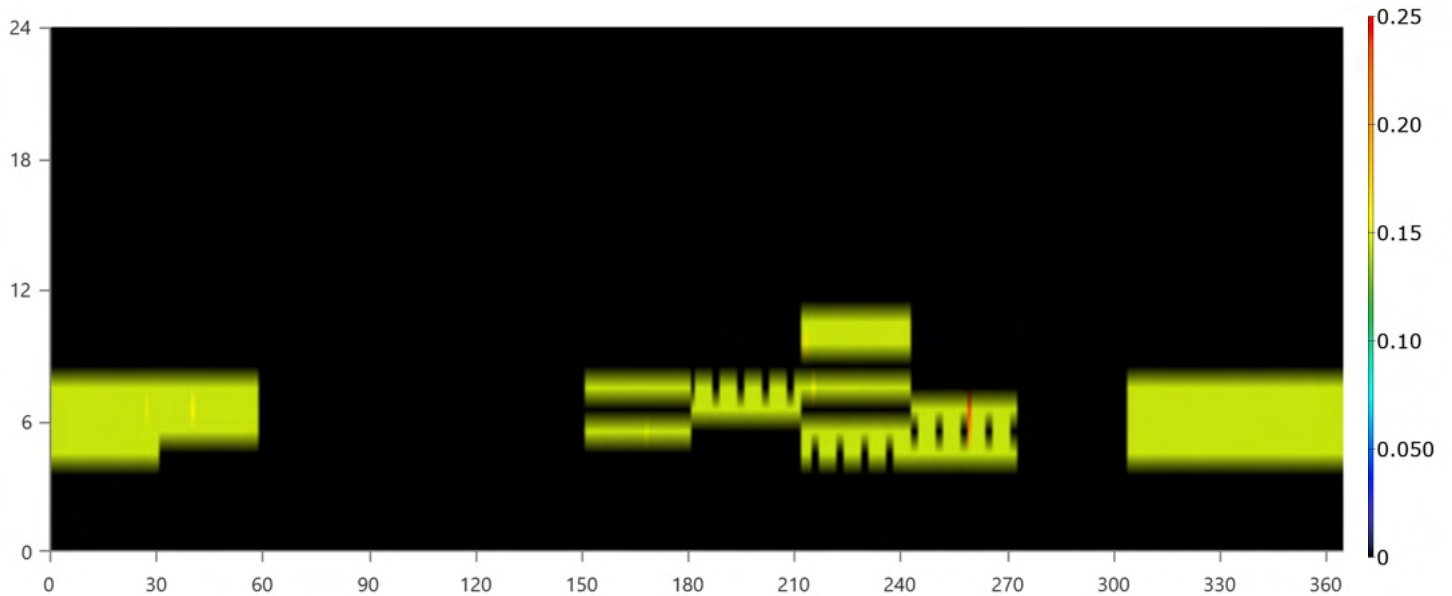

Biogas Consumption Statistics

Quantity	Value	Units
Total feedstock consumed	7.89	tons
Avg feedstock per day	0.0216	tons/day
Avg feedstock per hour	0.000901	tons/hour



Biogas Consumption (kg/hr)

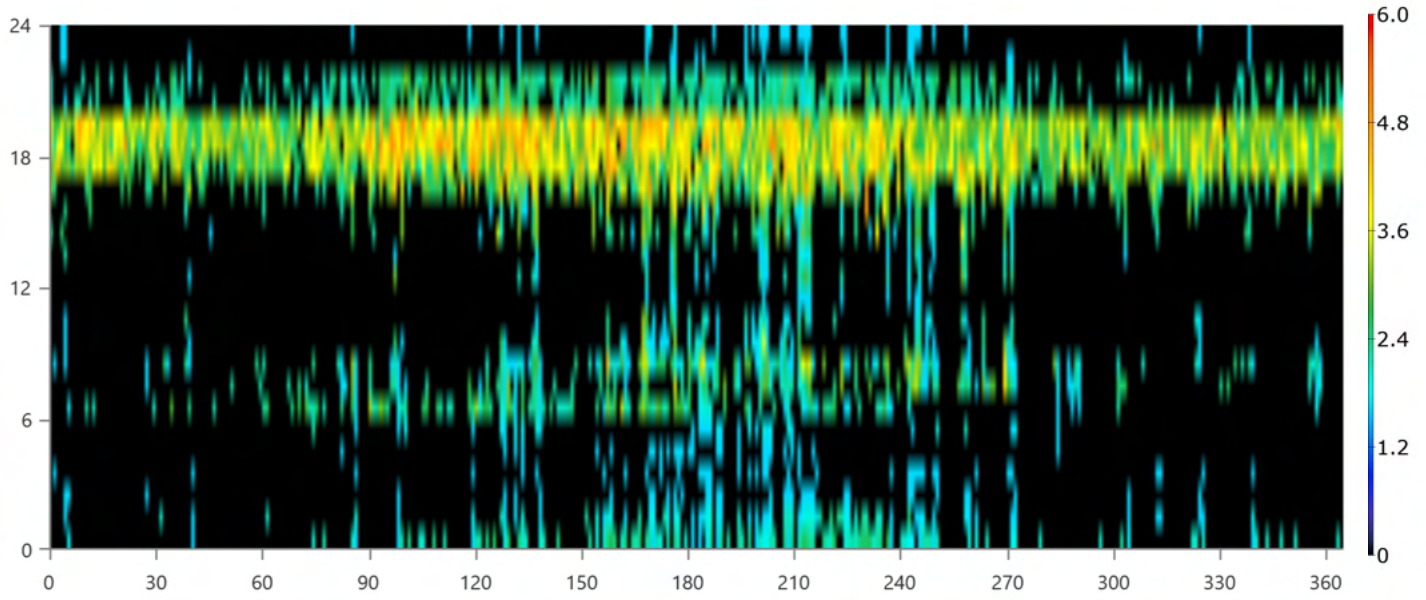

Emissions

Pollutant	Quantity	Unit
Carbon Dioxide	321	kg/yr
Carbon Monoxide	2.06	kg/yr
Unburned Hydrocarbons	0.0910	kg/yr
Particulate Matter	0.0124	kg/yr
Sulfur Dioxide	0.759	kg/yr
Nitrogen Oxides	1.94	kg/yr



Renewable Summary

Capacity-based metrics		Value	Unit
Nominal renewable capacity divided by total nominal capacity		81.6	%
Usable renewable capacity divided by total capacity		70.2	%
Energy-based metrics		Value	Unit
Total renewable production divided by load		107	%
Total renewable production divided by generation		96.5	%
One minus total nonrenewable production divided by load		59.0	%
Peak values		Value	Unit
Renewable output divided by load (HOMER standard)		887	%
Renewable output divided by total generation		100	%
One minus nonrenewable output divided by total load		100	%

Instantaneous Renewable Output Percentage of Total Generation

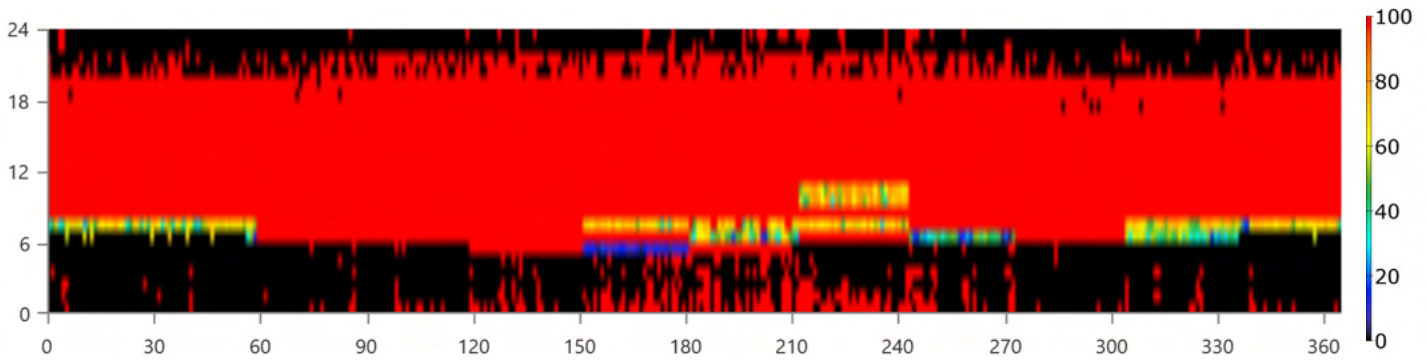

Instantaneous Renewable Output Percentage of Total Load

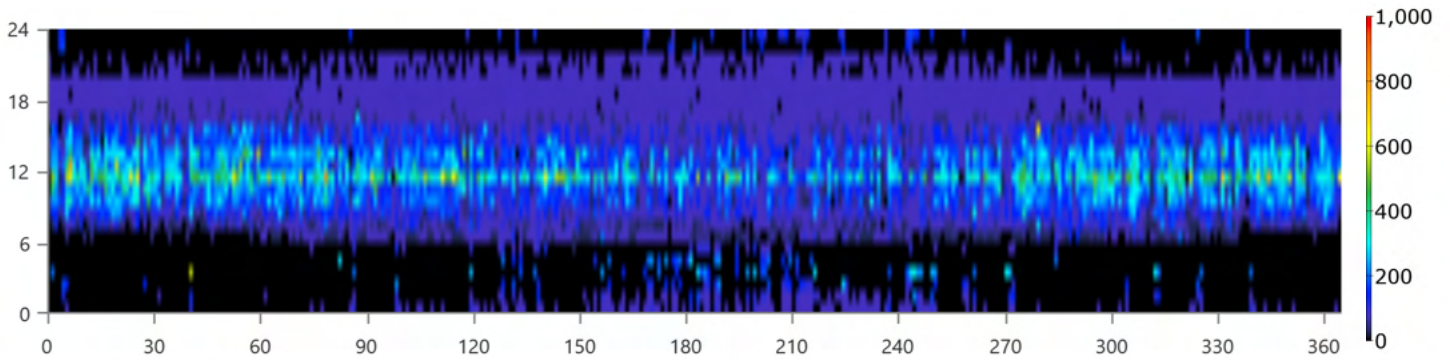

100% Minus Instantaneous Nonrenewable Output as Percentage of Total Load

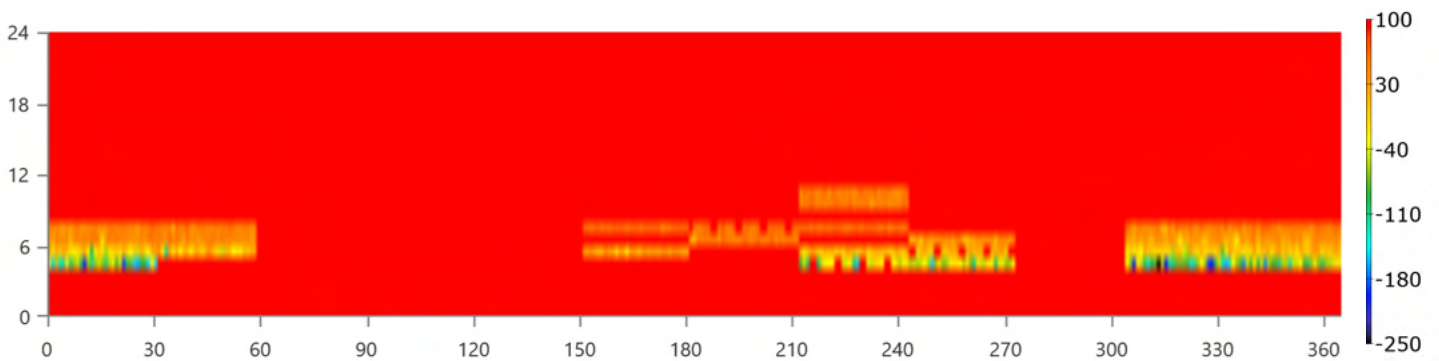



Compare Economics

IRR (%): **4.81**

Discounted payback (yr): **15.4**

Simple payback (yr): **13.5**

	Base System	Proposed System
Net Present Cost	\$29,878	\$28,804
CAPEX	\$10,070	\$14,021
OPEX	\$1,252	\$934.68
LCOE (per kWh)	\$0.184	\$0.177
CO2 Emitted (kg/yr)	500	321
Fuel Consumption (L/yr)	200	126



Proposed Annual Nominal Cash Flows

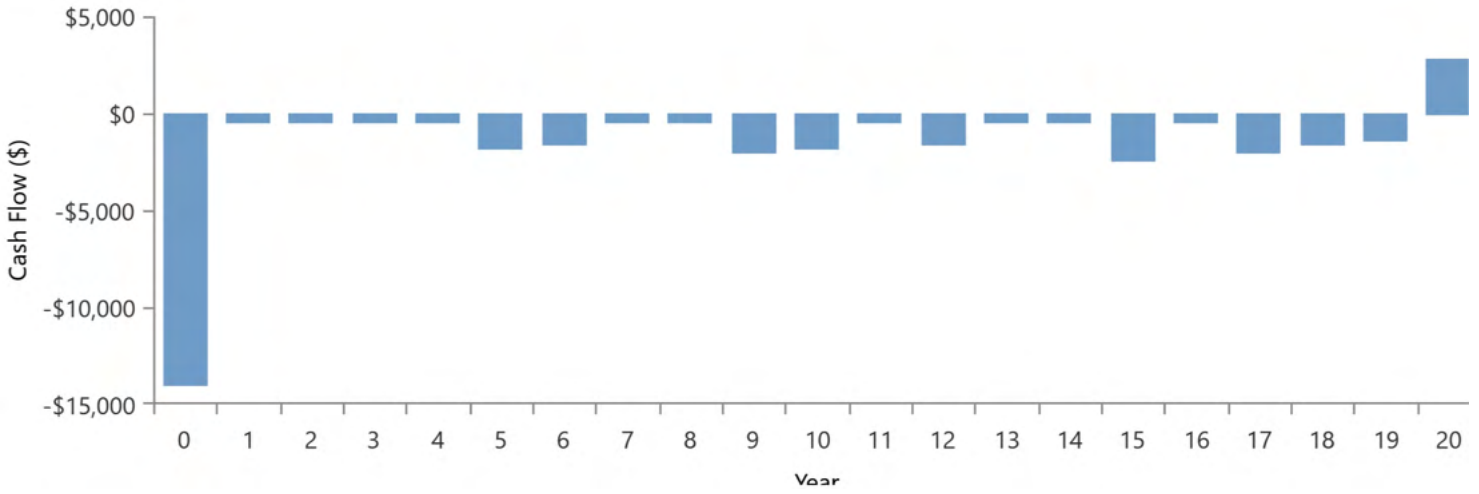

Base System Annual Nominal Cash Flows

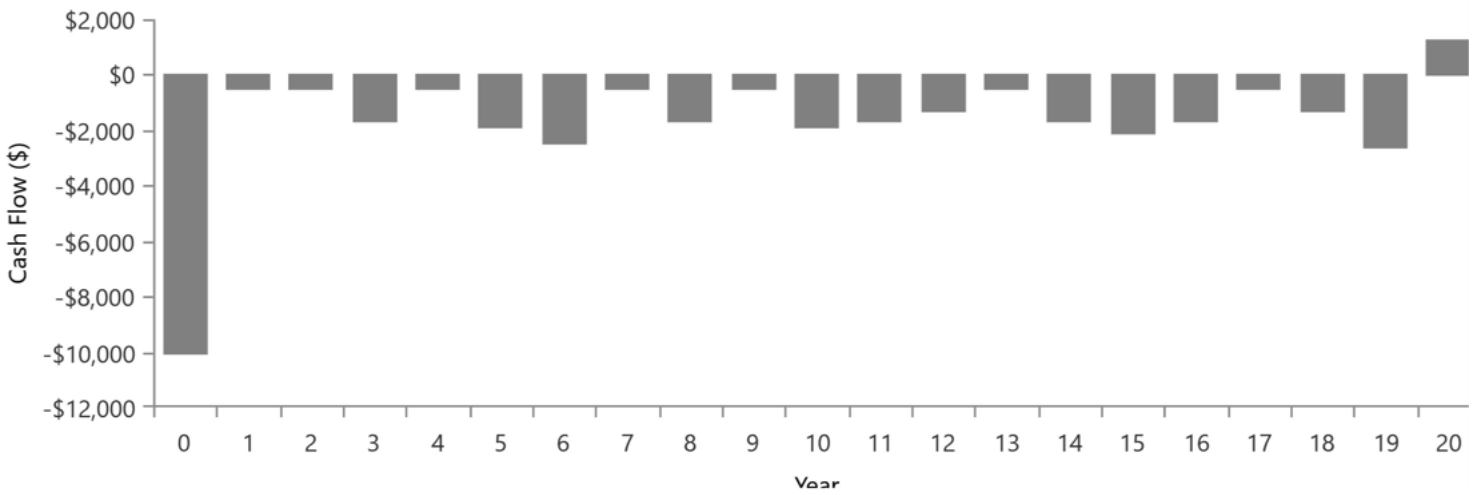

Cumulative Discounted Cash Flows

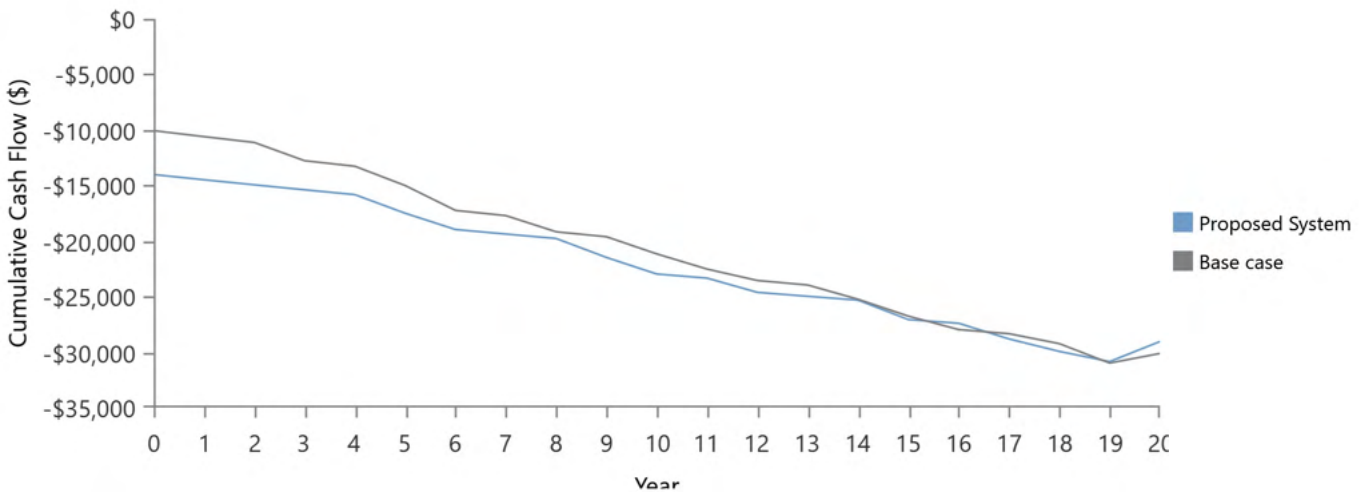



Time series charts:

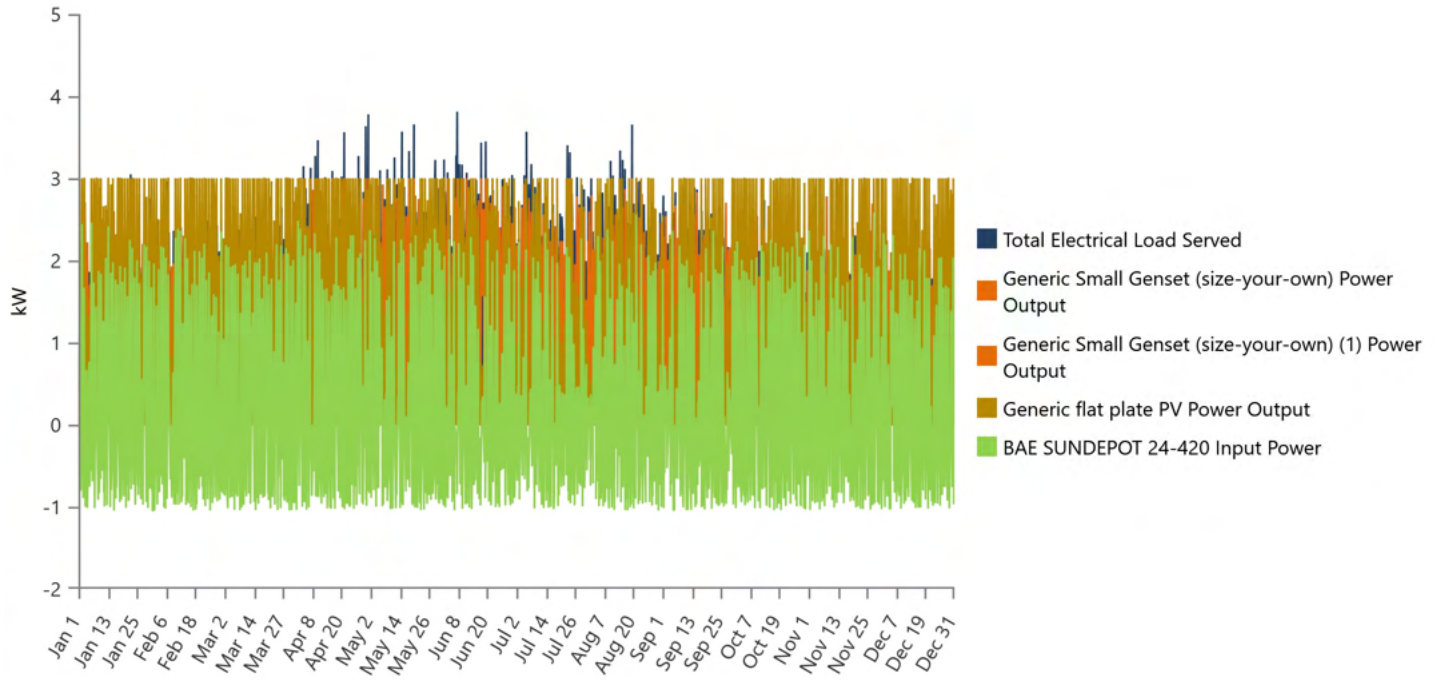



Time series charts:

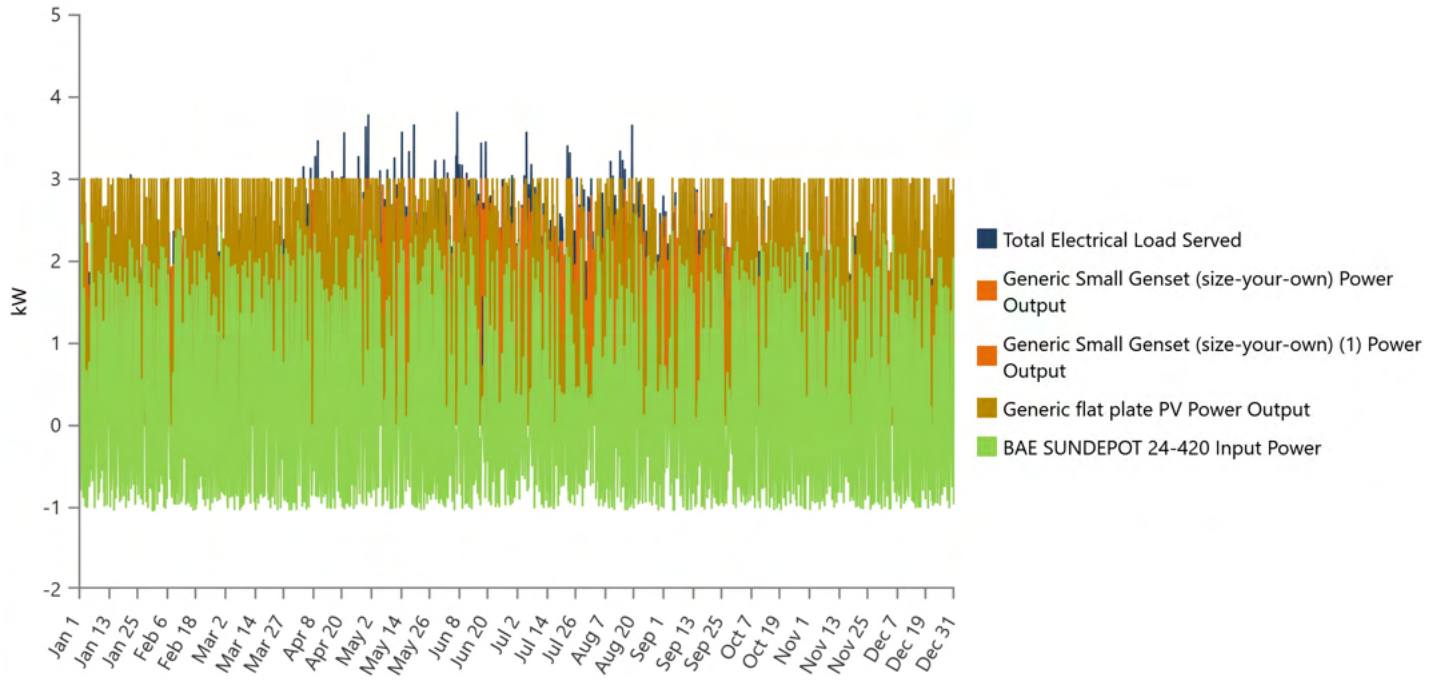



Time series charts:

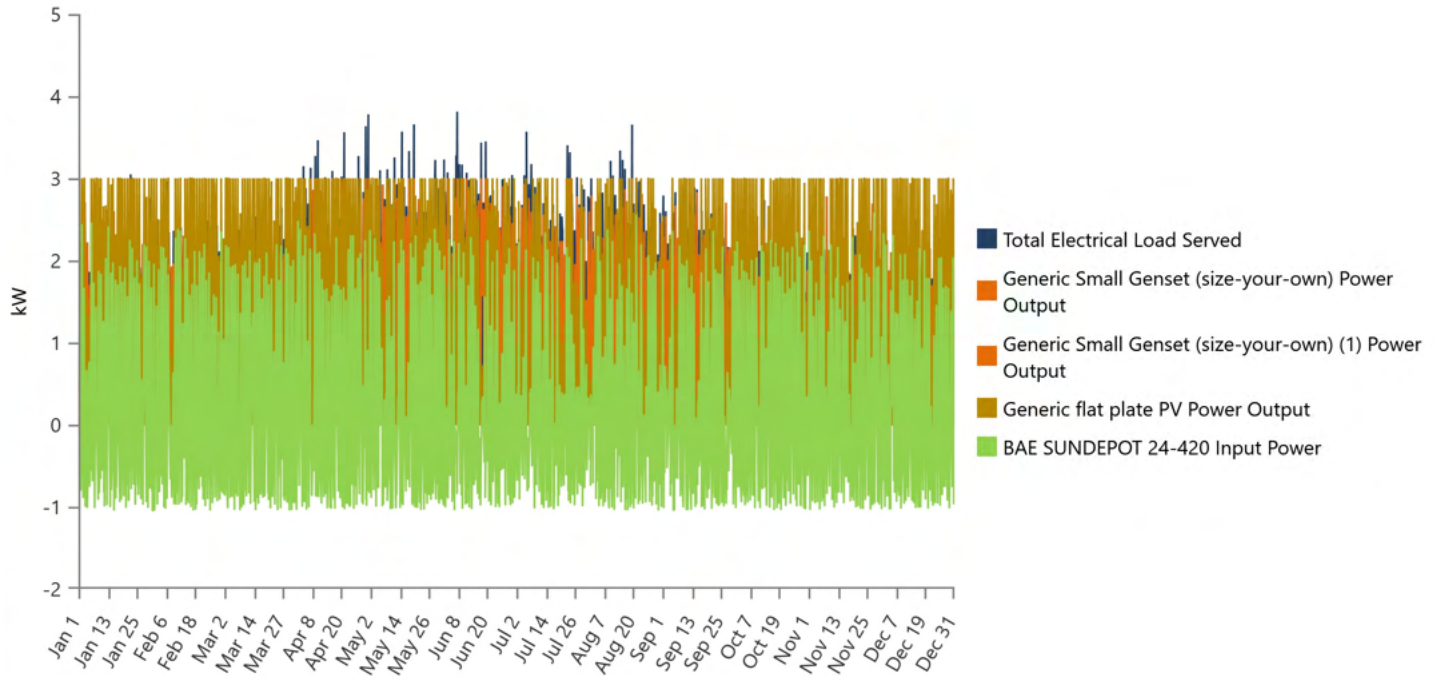



Time series charts:

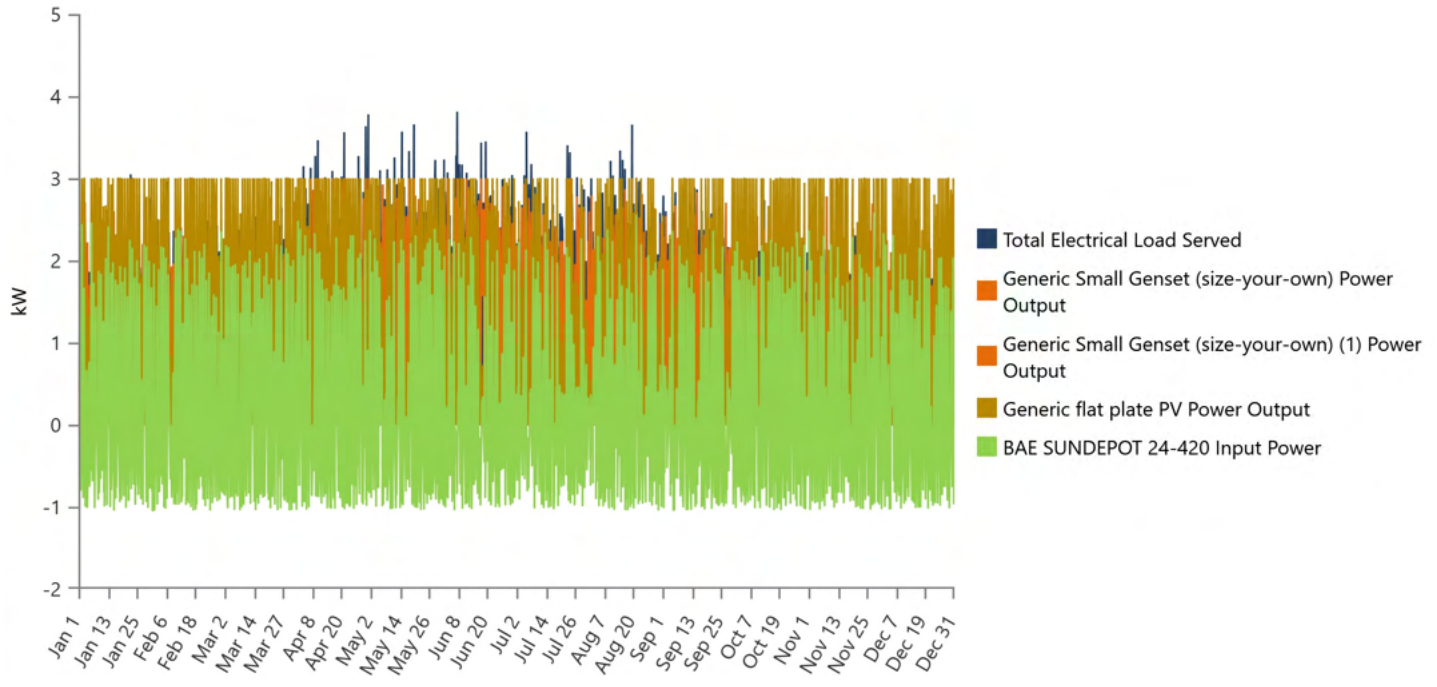



Time series charts:

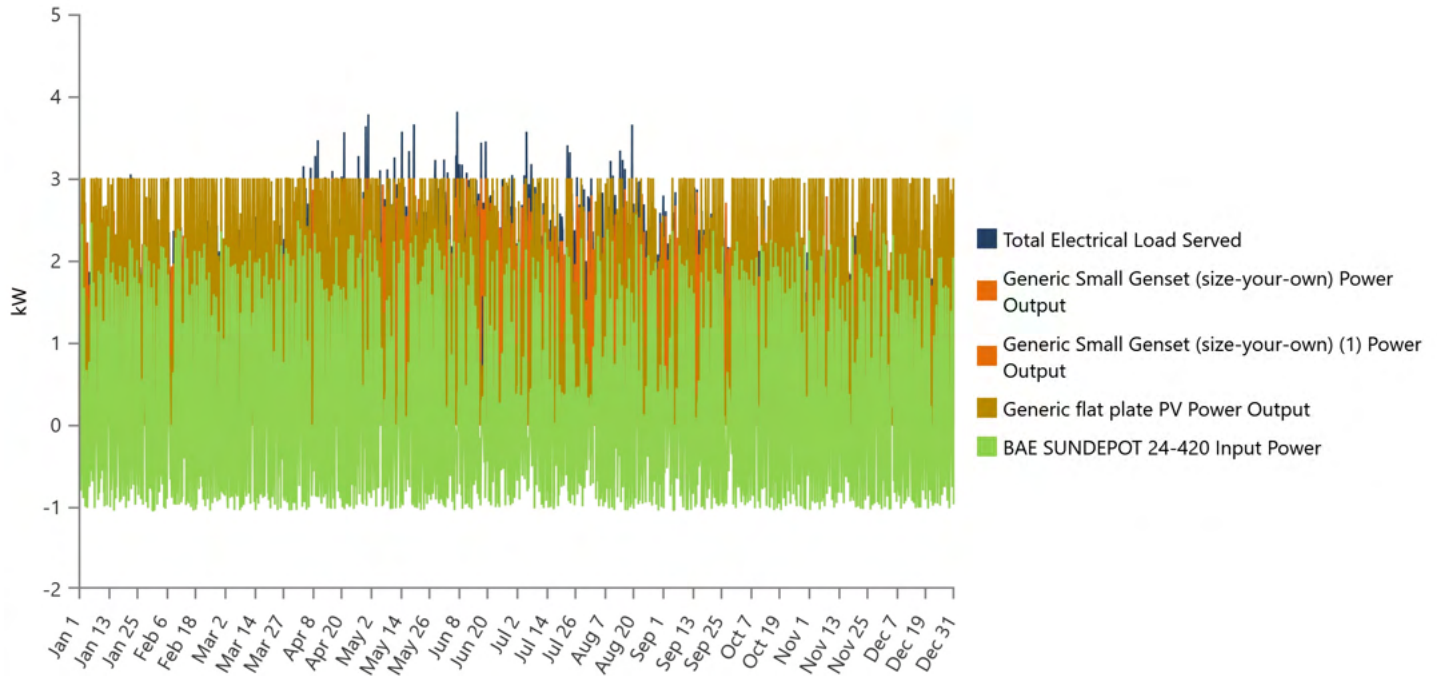



Time series charts:

