



**Daffodil**  
*International*  
**University**

**Faculty of Engineering**  
**Department of Textile Engineering**

---

*Title of FYDP: Men's Long Pant (Woven)*

---

**Submitted By**

**Name: Md. Mahmud All-Anwar**

**ID: 083-23-1079**

**Advised By**

**Md. Tanvir Ahmed Chowdhury**  
**Assistant Professor (Head of Department)**  
**Department of Textile Engineering**  
**Daffodil International University**

This Report Presented in Partial Fulfillment of the Requirements for the Degree of Bachelor of Science in  
Textile Engineering

Advances in Apparel Manufacturing Technology

8<sup>th</sup> Semester - 4th Year

## Author's Declaration

I hereby declare that I am the sole author of this project. This is the final version of the project report as approved by my advisor, Md. Tanvir Ahmed Chowdhury, including any required revisions. Furthermore, I grant Daffodil International University permission to reproduce this material in hard copy or electronic format and to distribute it for academic purposes.

---

Md. Mahmud All-Anwar

ID: 083-23-1079

E-mail: mahmud79@diu.edu.bd  
Department of Textile Engineering  
Daffodil International University

## Statement of Contributions

In this Final Year Design Project, I worked independently. I completed all tasks, including taking the measurements of the dummy, creating garment sketches, pattern making, fabric selection and collection, cutting, sewing, and finishing the garment. The washing process was carried out at a factory under the supervision of one of my teammates who is currently employed there. Additionally, I sought advice from a sewing expert to improve stitching quality. Throughout the project, I consulted with my advisor, Md. Tanvir Ahmed Chowdhury, who supervised each stage of the work until its completion.

## Executive Summary

In this Final Year Design Project, my objective was to produce a men's long pant, specifically a chino, based on the measurements of a male dummy available in our apparel laboratory. I selected this item to expand my experience beyond the typical garments—such as T-shirts, shirts, or leggings—usually taught during our coursework. Developing a men's long pant introduced me to additional measurement points and unique challenges, enriching my understanding of garment construction.

Throughout the project, I encountered several difficulties. For instance, the waist and bottom measurements of the pant differed, and there were design elements at the waist that required careful adjustment. Moreover, the front and back widths of men's pants must be different, with the front width generally being smaller than the back. To resolve these issues, I took multiple measurements, discussed corrections with the pattern master, and made necessary adjustments to achieve a proper fit.

With guidance from my advisor and assistance from a few industry experts, I aimed to create a distinctive and high-quality product for this final year project. This experience allowed me to apply my theoretical knowledge to a practical setting, covering measurement, pattern design, fabric selection, cutting, sewing, and finishing, and to successfully deliver a garment that meets academic and professional standards.

## Acknowledgments

First and foremost, I express my heartfelt gratitude to Almighty Allah for His divine blessings, which made it possible to complete this project successfully.

I would also like to convey my deepest appreciation to Mr. Md. Tanvir Ahmed Chowdhury, Associate Professor and Head of the Department of Textile Engineering at Daffodil International University, for his invaluable guidance and advice. His scholarly supervision, continuous encouragement, constructive criticism, and tireless support throughout every stage of this project made its successful completion possible.

# Table of Contents

## Contents

Author's Declaration.....	ii
Statement of Contributions.....	iii
Executive Summary.....	iv
Acknowledgments.....	v
List of Figures.....	viii
List of Table.....	ix
List of Abbreviations.....	x
List of Equations.....	xi
United Nations Sustainable Development Goals.....	xii
Chapter 1: Introduction.....	1
1.1 Background Information:.....	1
1.2 Significance and Motivation:.....	1
1.2.1 Significance:.....	1
1.2.2 Importance and benefits:.....	2
1.2.3 Aims and Objectives:.....	2
1.3 Methodology:.....	2
1.4 Report Outline:.....	2
Chapter 2: Literature Review.....	3
2.1 Introduction:.....	3
2.2 Limitations:.....	3
2.3 Summary:.....	3
Chapter 3: Manufacturing steps of Pant.....	4
3.1 Introduction:.....	4
3.2 Measurement:.....	5
3.2 Sketch creation:.....	6
3.3 Adjust the measurements:.....	11
3.4 Fabric collection and details:.....	13
3.5 Pattern Making:.....	14
3.6 Fabric Cutting:.....	15

3.7 Sewing: .....	15
3.8 Finishing: .....	18
3.9 Lab Test: .....	19
3.9.1 GSM Test:.....	19
3.9.2 Fabric inspection: .....	19
3.10 Garment inspection: .....	20
3.10.1 Shrinkage test:.....	20
3.10.2 Color Fastness test: .....	20
3.11 Summary: .....	21
Chapter 4: Project Submission.....	22
4.1 Introduction:.....	22
4.1 Lab Test Report: .....	22
4.1.1 GSM test Report:.....	22
4.2 Fabric Inspection Report: .....	22
4.3 Shrinkage test Report: .....	24
4.4 Garment Inspection Report: .....	24
4.5 Garment Inspection Report.....	25
4.6 Project Demo:.....	26
4.7 PO Sheet: .....	27
4.8 Result and Discussion: .....	28
4.9 Summary: .....	28
Chapter 5: Social Ethics .....	29
5.1 Introduction.....	29
5.2 Ethical principles and professional commitment involvement.....	29
5.3 Impact of the project on the environment and sustainability.....	29
5.4 Summary .....	29
Chapter 6: Conclusions .....	30
6.1 References.....	30

## List of Figures

<b>Figure No</b>	<b>Description</b>	<b>Page No</b>
<b>Figure 1:</b>	Marking of measurement points	17
<b>Figure 2:</b>	Front sketch of the frock	18
<b>Figure 3:</b>	The back-sketch of the frock	19
<b>Figure 4:</b>	Digital Drawing of the Frock and marking of measurement points	20
<b>Figure 5:</b>	Marking points according to the new modified measurement chart.	24
<b>Figure 6:</b>	98% cotton 2% elastane twill fabric. and construction.	25
<b>Figure 7:</b>	CAD file of the Front, Back and others all part	26
<b>Figure 8:</b>	Stitching location.	27
<b>Figure 10:</b>	Garment on the dummy.	37

## List of Table

<b>Table No</b>	<b>Description</b>	<b>Page No</b>
<b>Table 1:</b>	Adjusted and modified measurements	23
<b>Table 4:</b>	GSM test report chart.	34
<b>Table 5:</b>	Fabric inspection report.	35
<b>Table 4:</b>	Garment Inspection Report.	36
<b>Table 5:</b>	PO sheet	38

## List of Abbreviations

**SDGS** Sustainable Development Goals.

**GSM** Grams Per Square Meter

**CM** Centimeter

**CAD** Computer-Aided Design

**POM** Point of measurement

## List of Equations

Serial	Equation
01	$\text{Fabric length} = \frac{\text{fabric weight} \times 1000}{\text{fabric GSM} \times \text{Fabric width} \times 0.0254}$
02	$\frac{\text{Points}}{100 \text{ sq. yds}} = \frac{\text{Total point in roll} \times 100 \times 36}{\text{Total inspected fabric length (yards)} \times \text{fabric width}}$
03	$\text{GSM} = \text{Sample weight} \times 100$

## United Nations Sustainable Development Goals

The roadmap to a brighter and more sustainable future for all is found in the Sustainable Development Goals (SDGs). They tackle the world's problems, such as injustice, poverty, inequality, and environmental degradation as well as peace and justice. The list of SDGs is 17 in total, as follows. Verify the relevant SDGs for the project.

In this project, we use recycled yarn (7% cotton) to make the rib knit fabric. Again, we use dyed yarn which we know, consumes less water and chemicals than garment dyeing. So, if we want to categorize it in the SDGs, then we work on Sustainable Cities and Communities. At present, waste management is a huge problem. Even if for used cotton fabric. So, manufacturers collect the cotton used product then bring back it to yarn form then mix it with fresh cotton yarn only a small percentage. Because large percentages can lower the strength of the fabric. Also, dyed yarn uses less energy, dye, and chemicals to dyeing than garment dyeing. This way we try to contribute for the better future.

# Chapter 1: Introduction

## 1.1 Background Information:

In the final year design project, my challenged to create a real garment which is all done by me. Like, choose a design, adjust it with my dummy, take the measurements of the dummy to make the chosen garments, sewing, dyeing, finish, and finally present the final product which is fits with my dummy. To complete this project, I need to grow up the knowledge that how garments are made in the factory, how the factory minimizes process faults, how the garments' fault is adjusted, and how to make a proper decision in the moment of time and pressure. In this project design, I am worked with a different type of men's long pant product called Chino. The reason behind choosing this type of garment is i am all learning to take measurements, make patterns, and identify the point of measurement of basic Shirts (woven), T-shirts (knit), and jeans (Woven). But there are also a few different points of measurement, types of measurement, and different designs which provide me a different learning scope. Also, i am wanted to do some work by leaving our comfort zone. I am also identified that in the process of making flock for my dummy measurement, we need to acknowledge for creation of additional decoration and its placement, continuously modify the design according to the work process, and learn about woven fabric and construction.

## 1.2 Significance and Motivation:

### 1.2.1 Significance:

As a student of the Textile Engineering department, I should be measuring almost any type of garment or clothing. Should be named the point of nearly all points of measurement. But in our academic book, we only learn about basic garments and their measurement. Again, as Textile Engineering, we should be aware of how to make a garment from sketch and fabric. Not just academic knowledge but also real-world experience. During making garments from a design and fabric, there were many technical issues, I faced. And try to solve it. I believe this knowledge will help me in the industry and understand the manufacturing process very easily and can work efficiently.

### 1.2.2 Importance and benefits:

Through this project, i have learned to

1. Make Garments from the measurements of the dummy.
2. Draw the sketch of a piece of clothing according to the measurement.
3. Adjust the measurement of clothing for better fitness.
4. Collecting and attaching decoration items.
5. And overall manufacturing process.

### 1.2.3 Aims and Objectives:

1. To make garments beyond basic garments.
2. Gather knowledge of a few unknown points of measurement.
3. Gather knowledge of the garment manufacturing process practically.
4. Know more about woven fabric and woven garment manufacturing
5. Gather practical knowledge and solve the issues that occur during manufacturing.

### 1.3 Methodology:

In the beginning, when i decided to make a project, I am started to search an idea of how can i make different clothing but not too complex which seemed impossible to make. Then i generate an idea like that, in the cold weather when it is not the time for heavy sweeter, or normal clothing but feel cold in the outside. That time carrying a sweater is like a burden. And if we wear a sweater, we feel very dazed. Again, clothing should be comfortable in that weather and, at the same time fashionable. Based on this thought, i am designed clothing which is made by cotton elastane twill fabric that is comfortable to wear. Because cotton elastane twill fabric is heavier than normal clothing that provides comfort in all-weather as an alternative to sweaters. So, i designed a men's long pant item, called Chino. Because of high GSM (245) and for cotton fiber it provides feel which is so much more comfortable in all weather. Again, we used few decoration items to make the pant more fashionable.

### 1.4 Report Outline:

Through this project report, I am briefly discussed how I make this clothing, called Chino. In the 1st chapter, I mentioned my motivation, importance, and methodology of the item. In the rest of the chapter, I will discuss the manufacturing process, fabric (Woven) construction details, and testing report as well.

## Chapter 2: Literature Review

### 2.1 Introduction:

For this project work, I made a men's long pant item, called Chino. It is not actually a new product but, in our lab, it is new to create. No one has done it before in here. Again here, i used a little percentage of recycle yarn to woven fabric. That makes my project different from others. I am making a difference by creating an item for adult males. For that measurement, fitting and decoration is more important because the test of an adult male. So, I am trying to include their will in that item. So that it can match adult's acceptance along with comfort.

### 2.2 Limitations:

I need to remove excess decoration to meet the adult acceptance. Moreover, I cannot make a free-size style that can be worn by most adult males. Furthermore, the design and fabric construction cannot provide much warmth in extremely all weather. Lastly, i could not add any more recycled yarn to maintain the fabric's optimum strength and durability. Also, perfect fitting may not happen because of a lack experience of in sewing and other factors.

### 2.3 Summary:

This project is all about the manufacturing process of long pant. Instead of having some limitations, I am trying hard to make it as perfect as possible. In the time being, if anyone showed their interest it this process, these limitations are scope for them to improve as much as they can.

## Chapter 3: Manufacturing steps of Pant

### 3.1 Introduction:

Here I create a long pant for an adult male person. To complete this project and to describe the manufacturing process effectively, I am divided it in such ways.

- a. Measurement.
- b. Sketch creation.
- c. Adjust the measurements.
- d. Fabric and Accessories collection and details.
- e. Pattern Making.
- f. Cutting the fabric.
- g. Sewing.
- h. Finishing.

### 3.2 Measurement:

For this project, I have taken the initial measurement of our lab dummy(male). I am identifying the point of measurement as we learn academically. I have taken all the measurements on a CM (centimeter) scale. I am also do not take any extra allowance at the initial stage. Because of making sketches, I needed actual body measurements. After that, I have added the allowance (sewing) throughout the period of making the pattern and CAD file.

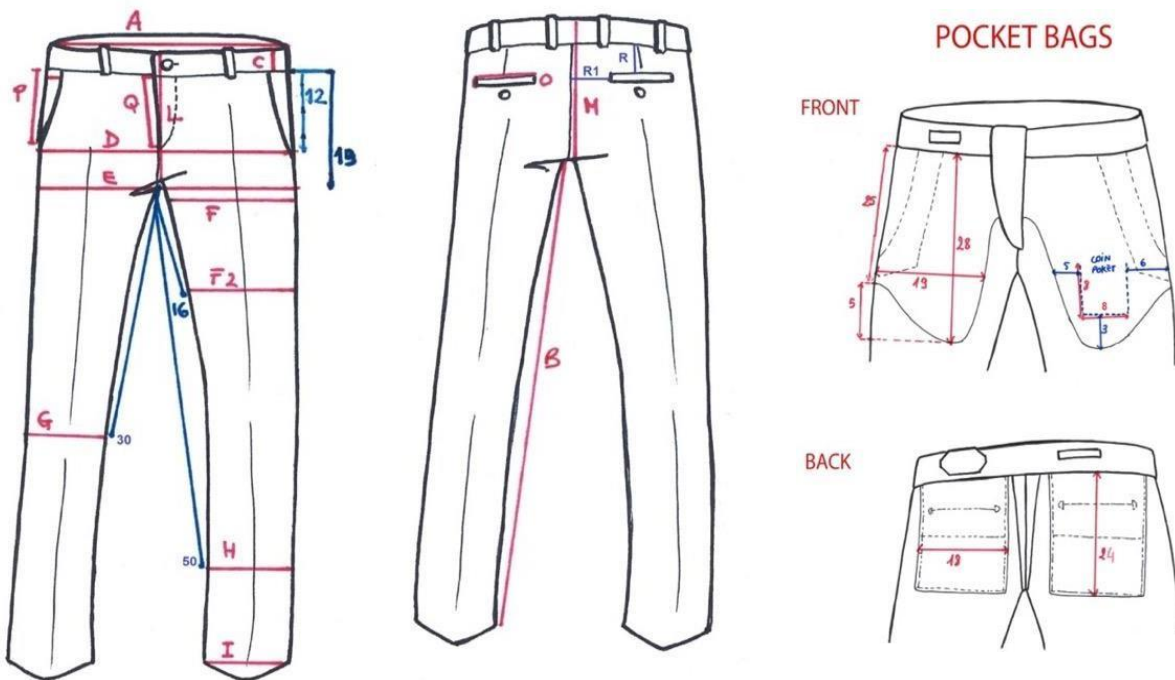

Figure 1: Marking of measurement points

Before the garment's selection, I am initially taking the measurement of the dummy so that it could help us understand and select the garments.

### 3.2 Sketch creation:

I chose to make a men's long pant item, called a Chino. So first, i need to make a sketch of the product. I will identify the different POM and adjust the measurement. So that i can make a garment which can fit with the dummy.

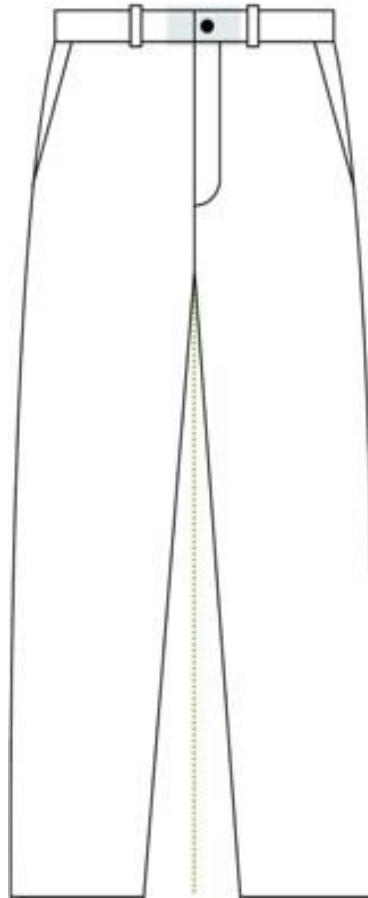

Figure 2: Front sketch of the Pant

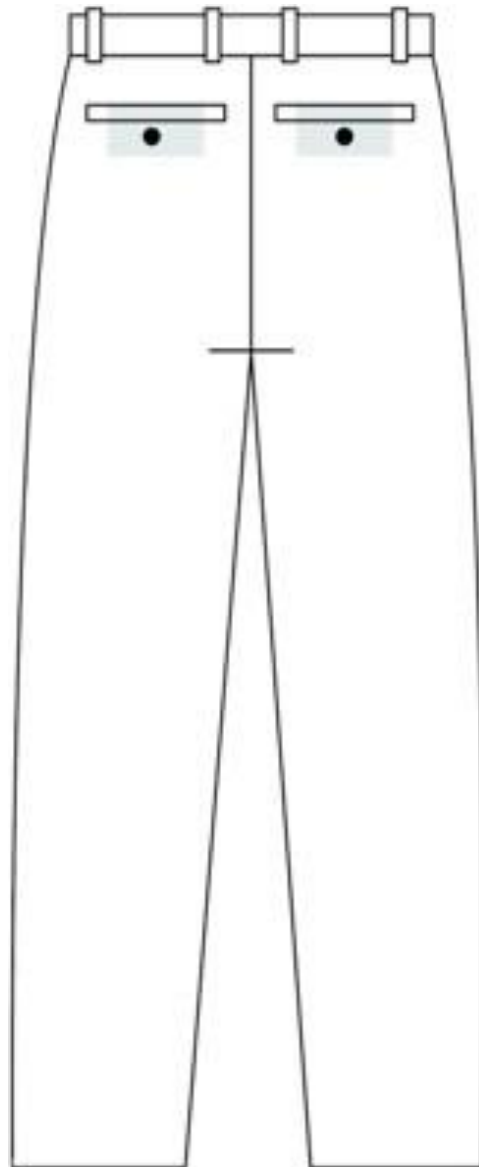

Figure 3: The back sketch of the Pant

After finalizing the design and a few modifications, I make a digital drawing of the chino and identified the POM and by marking the number.

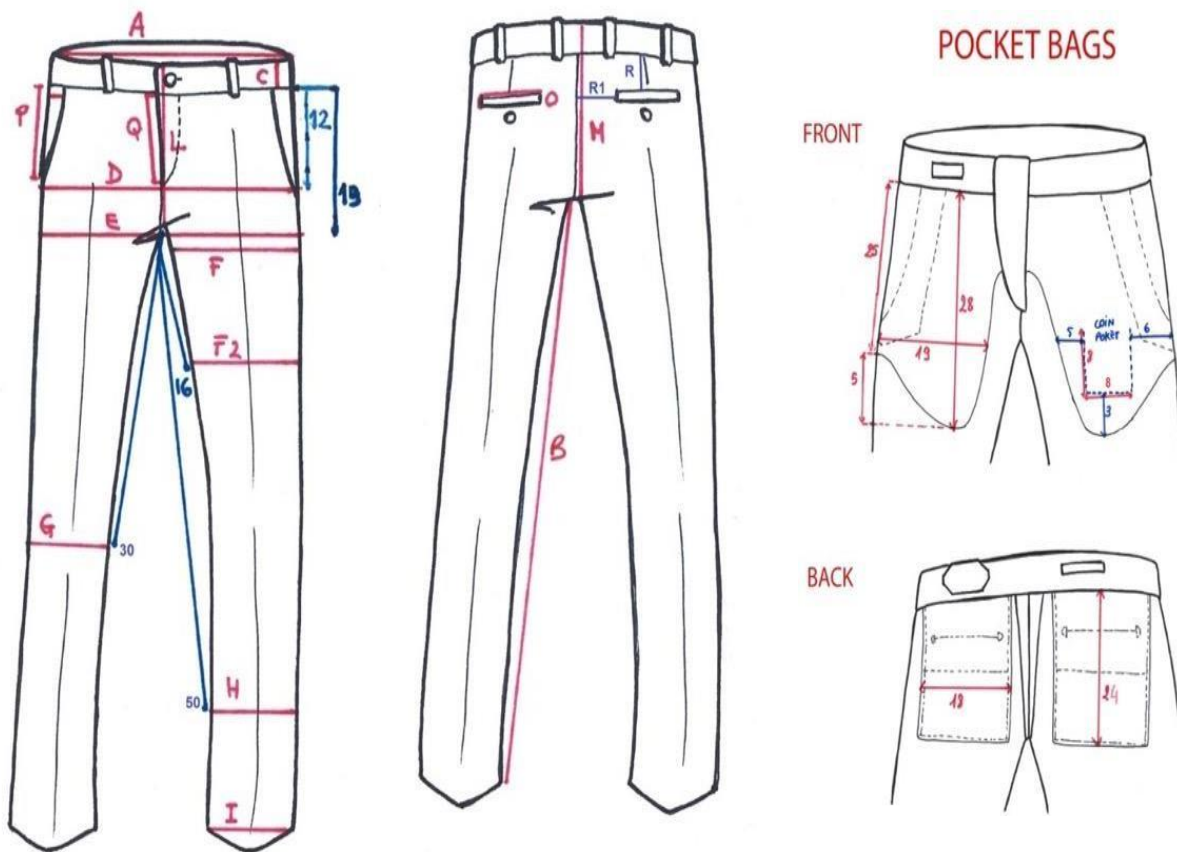
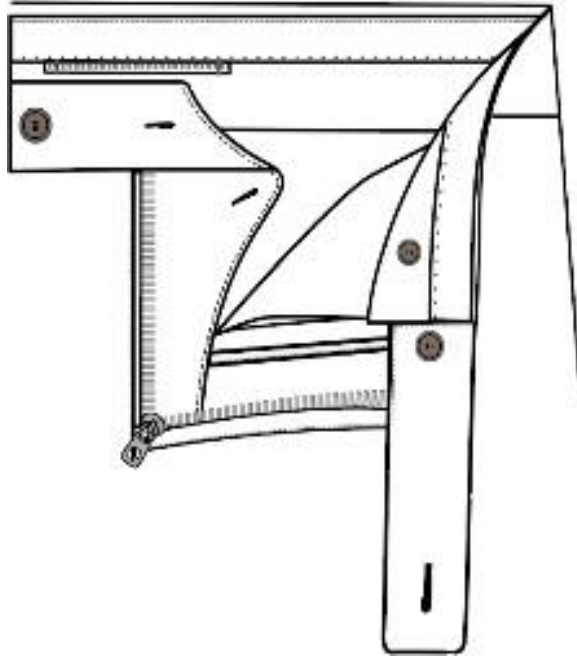

Figure 4: Digital Drawing of the long pant and marking of measurement points

**FRONT SIDE OUTER VIEW**



**FRONT SIDE INNER VIEW**

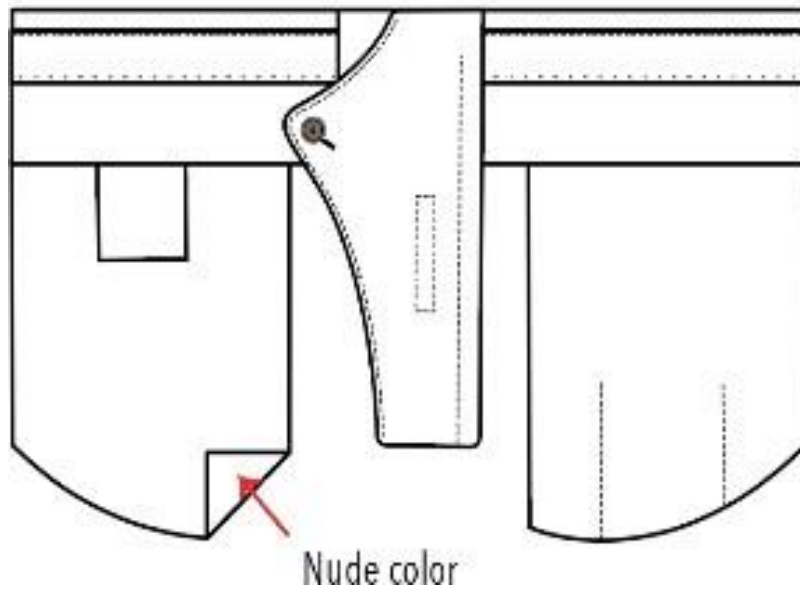

Figure 4: Digital Drawing of the long pant and marking of measurement points

**BACK SIDE INNER VIEW**

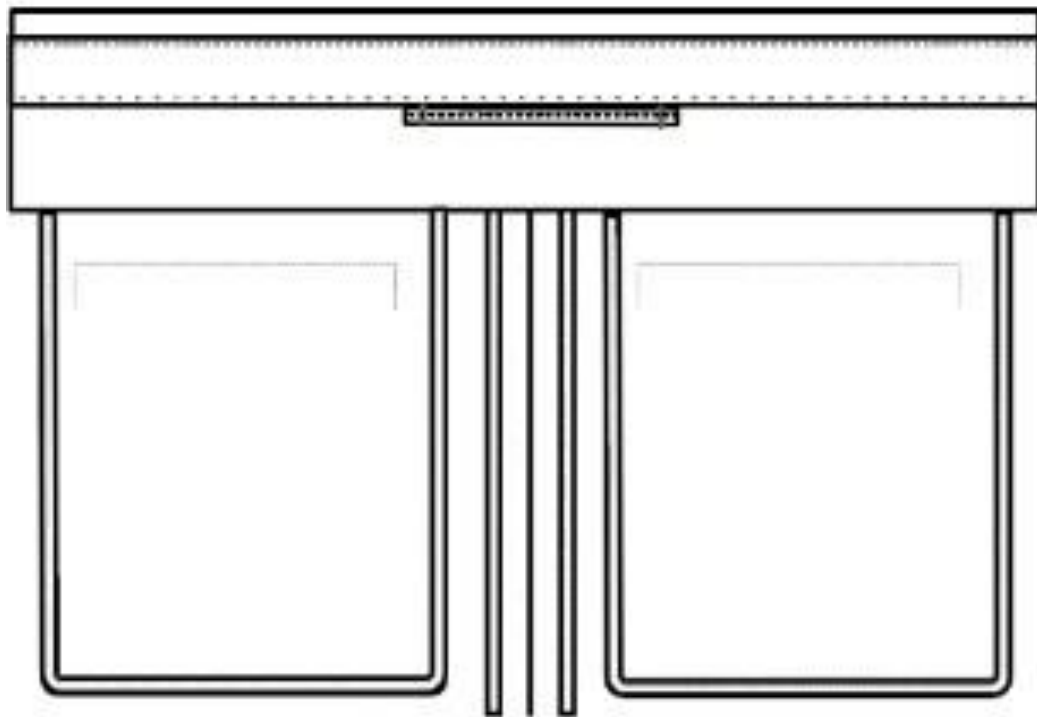

Figure 4: Digital Drawing of the long pant and marking of measurement points

### 3.3 Adjust the measurements:

According to the design i have chosen, it seems that there need to be of some measurement. So, we need to adjust and reconsider the measurement and modify it as per design and mark the point of measurement so that it can help to create the pattern.

**Table 1:** Adjusted and modified measurements

Serial	POM mark	POM	Measurement (inch)
1	A	1/2 Waist straight <b>UPPER POINT</b>	43
2	C	Waist band height	3.5
3	D	1/2 Hip <b>(12cm below w/b)</b>	52
4	E	1/2 Hip <b>(19cm below w/b)</b>	54
5	L	Front rise incl.w/b	27
6	M	Back rise incl.w/b	41
7	Q	Zip lenght	15
8	Q1	Fly width	3.5
9	B	Inseam	78
10	F	1/2 Thigh (1cm from crotch)	33
11	F2	1/2 Thigh (16cm from crotch)	27
12	G	1/2 Knee (30cm from crotch)	23.5
13	H	1/2 Calf (50cm from crotch)	21
14	I	1/2 Bottom leg opening	19
15	I2	Bottom hem stitching height	3.5
16	P	Hand pocket opening length	17
17	P1	Hand pocket opening width	2
18	O	Back pocket opening length	14
19	O1	Back pocket height	0.5
20	R	Back pocket position from waistband	7
21	R1	Back pocket position from center rise	6

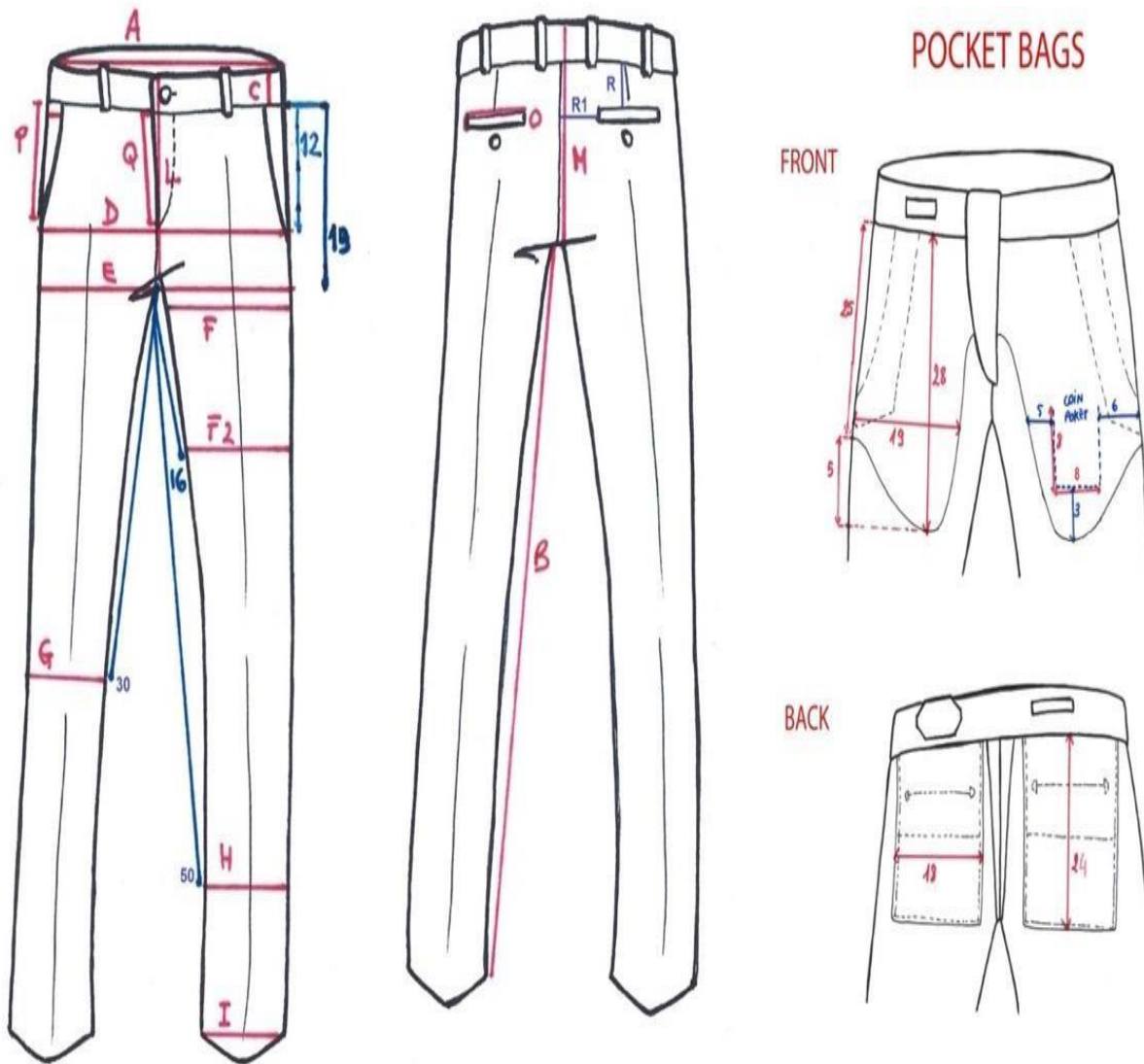
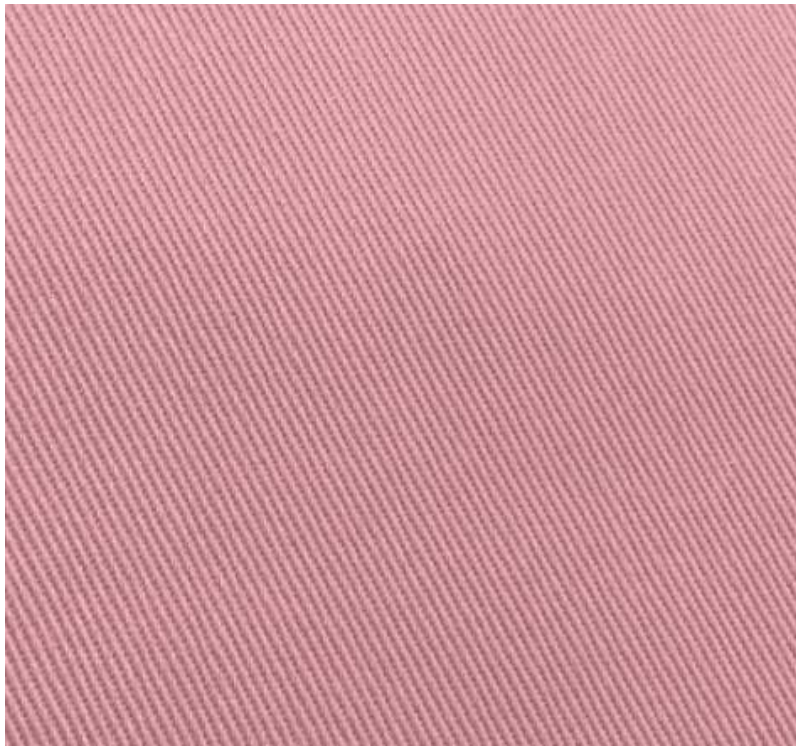

**Figure 5:** Marking points according to the new modified measurement chart.

### 3.4 Fabric collection and details:

To make this garment, we used knit rib fabric.

98% cotton 2% elastane twill fabric. As picture,



**Figure 6:** 98% cotton 2% elastane twill fabric.

### 3.5 Pattern Making:

In this step, I am first made the pattern design according to the final modified measurement.

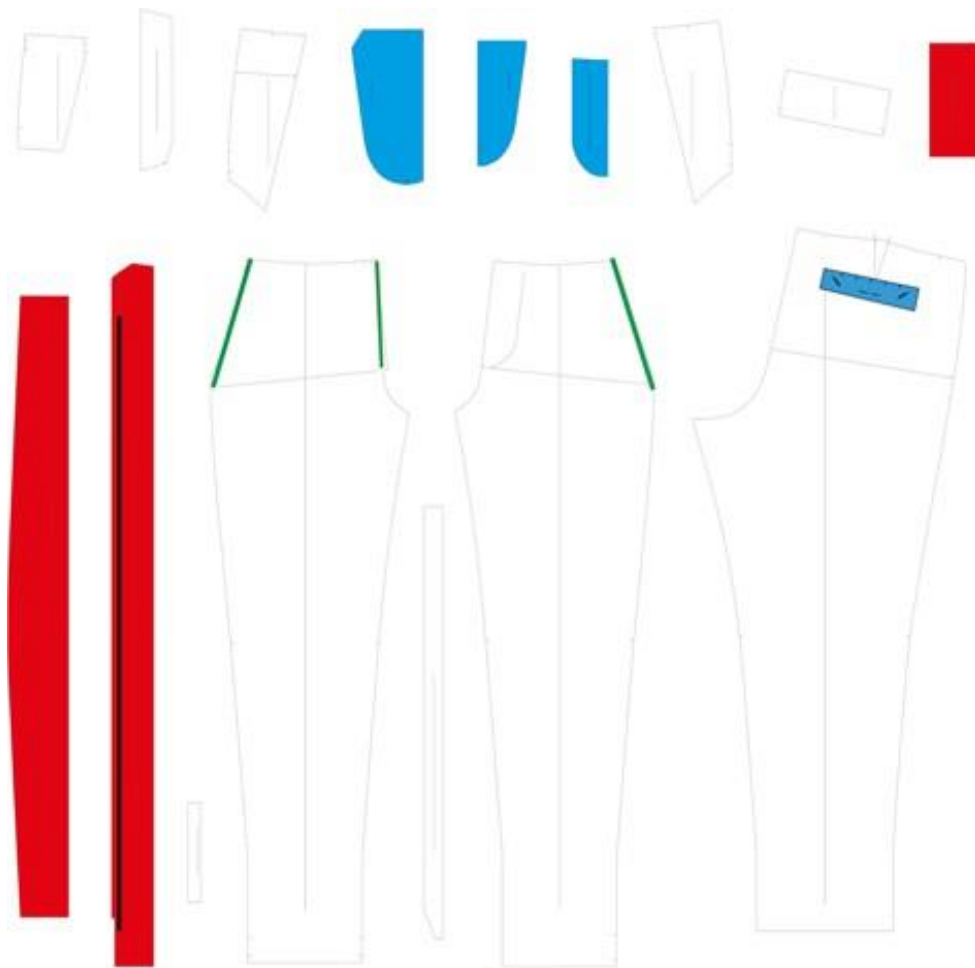

**Figure 7:** CAD file of Front, Back and others all part.

### 3.6 Fabric Cutting:

After making the CAD file, I carefully draw the pattern on a pattern paper. And on a masking paper. After drawing the pattern, I am cut all the pieces from the pattern paper. Then I spread the fabric and placed the pattern cut pieces on it according to the grain line. Then draw the pattern on the fabric by draw the outline of paper pattern pieces.

### 3.7 Sewing:

In the garment, i did two types of seams, one is superimposed seam and the other is a lapped seam. The superimposed seam is done by overlock stitch and almost all place seam lines in the garments. And the other one is a lapped seam done by a single lock stitch. Almost all over the garment, i used to overlock stitch for stitching because,

- Security of stitches is very good.
- Abrasion resistance of lock stitch better.



**Figure 8:** Stitching location



**Figure 8:** Stitching location

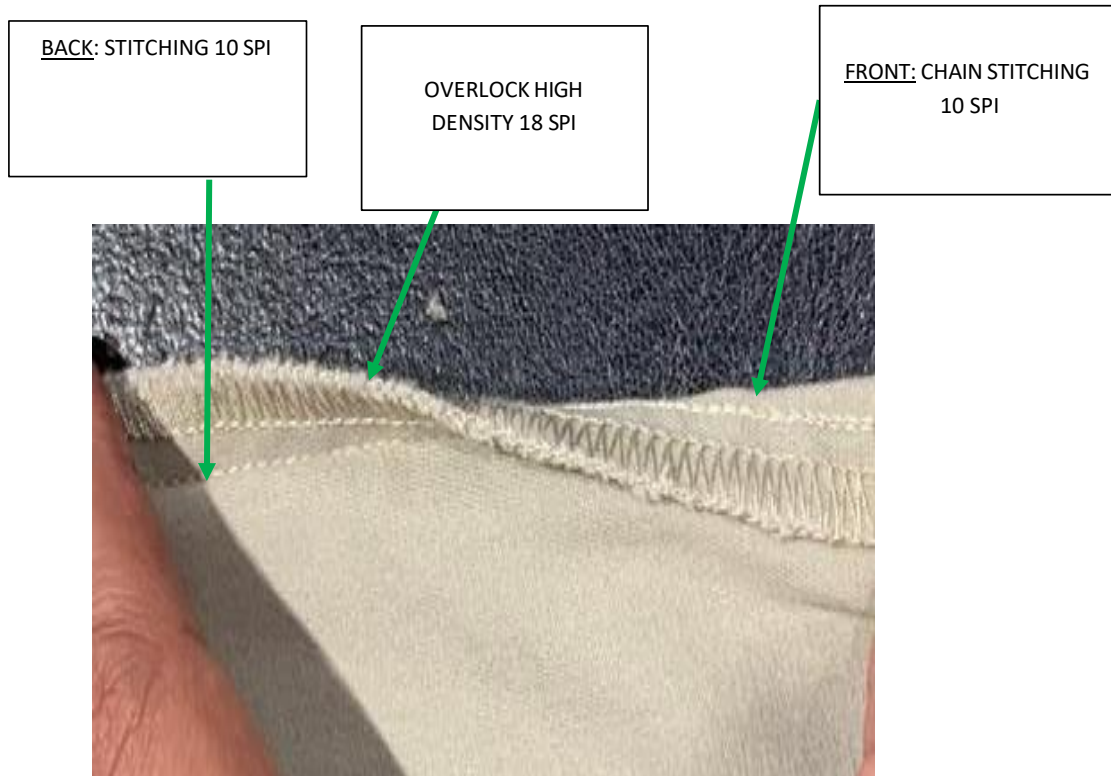

**Figure 8:** Stitching location

### 3.8 Finishing:

To complete this project i am, collected the twill fabric and the fabric was made of 98% cotton yarn containing 2% elastane. So, this fabric was already passed through the surface finishing process. But after sewing, i wash the fabric with detergent to clean the sewing dust and then iron the garment and make ready to wear the dummy.



**Figure 9:** Finishing

### 3.9 Lab Test:

#### 3.9.1 GSM Test:

At first, after collecting the fabric, I am testing GSM of the fabric so that we can conduct another test on it. And knowing the GSM is very important to describe the fabric properties and testing. For that I used out lab GSM Cutter to cut the fabric and used the following equation to find out the GSM of the fabric, here we use a GSM cutter whose area is 1/100 square meter.

So,  $GSM = \text{weight of the fabric which is cut by GSM cutter} \times 100$

#### 3.9.2 Fabric inspection:

Fabric is the main part of garments. So, to maintain proper quality fabric is first to inspect. After collecting the fabric, i am check the fabric by 4 4-point system inspection method. The reason to call it 4-point system is, that it does not matter how big the fault is, its maximum point will be 4. But to conduct 4-point system, i need to find out a few values to.

$$\text{Fabric length} = \frac{\text{fabric weight} \times 1000}{\text{fabric GSM} \times \text{Fabric width} \times 0.0254}$$

Here,

our Fabric GSM = 270.

Fabric weight = 1.12 kg.

Fabric width = 46 inches.

After that, i needed to convert the length to yards. So that we can input the value into the 4-point system equation.

$$\frac{\text{Points}}{100 \text{ sq. yds}} = \frac{\text{Total point in roll} \times 100 \times}{36 \text{ Total inspected fabric length (yards) fabric width}}$$

By this formula, we inspect our fabric in the lab.

### 3.10 Garment inspection:

To inspect the garments, i am finally measure the garment to ensure that my garment made according to the measurement i meant to or not. Though i measure on a centimeter scale my final garments inspection will find the measurement is the same as given or it changes if it changes then how much changes on ( $\pm$ )1/10 cm scale.

#### 3.10.1 Shrinkage test:

The British Standard provides broad instructions for preparing and labeling samples. A sample size of at least 300 x 300 mm is deemed enough for normal work, whereas 500 x 500 mm is advised for crucial work. As seen in Figure, the samples are marked with three sets of markings in each direction, spaced at least 350 mm apart and at least 50 mm from each edge. The markers are placed 250 mm apart and 25 mm from the edge in the case of the smaller sample.

#### 3.10.2 Color Fastness test:

The fastness of the color shade is a dyed material's most significant characteristic.

Color fastness is the ability of dyed or printed textile materials to retain their color when subjected to a variety of environmental factors, such as water, light, rubbing, washing, sweat, etc., both during the production process and during regular usage.

color fading of the item under test, or variations in its color.

bleeding of color staining from undyed material that comes into touch with the specimen during the test'

### 3.11 Summary:

In this Final Year Design Project, I chose to develop a men's long pant, specifically a chino, using a woven cotton-elastane twill fabric. Throughout the project, I carefully followed each step of the garment manufacturing process, starting with taking measurements from a male dummy, drafting the pattern, adjusting measurements as needed, and preparing the final design. I collected and inspected the fabric, performed all necessary cutting and sewing processes, and completed finishing steps such as washing and ironing.

The completed garment was subjected to a series of tests, including GSM testing, fabric inspection, shrinkage testing, and color fastness tests, to ensure quality and proper performance. The results confirmed that the garment met the desired measurements and quality standards.

This project gave me the opportunity to apply my academic knowledge to a real-world manufacturing context. It enhanced my understanding of pattern making, garment fitting, fabric testing, and quality control. By overcoming various technical and design challenges, I successfully produced a high-quality men's chino pant that demonstrates both practical skills and theoretical knowledge gained throughout my studies.

## Chapter 4: Project Submission

### 4.1 Introduction:

For any project, lab testing and presenting the final product provides the actual properties, quality, and outlook view. Here i submit the garment and also the test report for our work final evaluation.

### 4.1 Lab Test Report:

#### 4.1.1 GSM test Report:

I am used my lab GSM Cutter to cut the fabric and used the following equation to find out the GSM of the fabric, here i use a GSM cutter whose area is 1/100 square meter.

**Table 2:** GSM test report chart

Observation No.	Sample Type	Sample Weight (gms)	<i>GSM = Sample weight x 100</i>	Average GSM
1	Twill Fabric (woven)	2.42	242	243~245
2		2.40	240	
3		2.45	245	
4		2.48	248	
5		2.40	240	

The required GSM of the fabric is 245.

### 4.2 Fabric Inspection Report:

Here,

our Fabric GSM = 245.

Fabric weight = 1.12 kg.

Fabric width = 46 inches.

$$\text{Fabric length} = \frac{\text{fabric weight} \times 1000}{\text{fabric GSM} \times \text{Fabric width} \times 0.0254}$$

$$\mathbf{Fabric\ length} = \frac{\mathbf{1.12 \times 1000 \times 1.09361}}{\mathbf{245 \times 46 \times 0.0254}}$$

Fabric length = 4.278 yds

We can detect the faults and points,

**Table 3:** Fabric inspection report

Fabric	Length	width	3>	3<6	6<9	9<	<1(hole)	1<(hole)	Total Points	$\frac{Points}{100^2m}$	Grade
Twill	4.278	46	0	0	0	0	1	0	1	20.1568	A

$$\frac{Points}{100 \text{ sq. yds}} = \frac{Total \text{ point in roll} \times 100 \times 36}{Total \text{ inspected fabric length (yards) fabric width}}$$

This fabric is A-grade fabric.

### 4.3 Shrinkage test Report:

Fabric Sample no	Original Dimension		Dimension after wash		Change in dimension		Dimension change %	
	length	Width	length	Width	length	Width	length	Width
01	300mm	300mm	323.4	323.9	23.9	23.9	7.8	7.967
02	300mm	300mm	324.1	325	24.1	25	8.03	8.33
03	300	300	323.9	324.3	23.9	24.3	7.967	8.1

The Shrinkage percentage is avg 8.03%.

### 4.4 Garment Inspection Report:

Sample Number	1	2	3
Dry	3-4	4-5	3-4
Wet	4	4	3-4

The Color fastness report is,

In Dry sample color Fastness is Good to Excellent.

In Wet sample color Fastness Good.

## 4.5 Garment Inspection Report:

**Table: 4 Garment Inspection Report:**

Serial	POM mark	POM	Measurement (inch)	On Garment(inch)
1	A	1/2 Waist straight <b>UPPER POINT</b>	<b>43</b>	+1/2
2	C	Waist band height	<b>3.5</b>	√
3	D	1/2 Hip ( <b>12cm below w/b</b> )	<b>52</b>	√
4	E	1/2 Hip ( <b>19cm below w/b</b> )	<b>54</b>	-1/2
5	L	Front rise incl.w/b	<b>27</b>	+1/2
6	M	Back rise incl.w/b	<b>41</b>	+1/4
7	Q	Zip lenght	<b>15</b>	+1/4
8	Q1	Fly width	<b>3.5</b>	√
9	B	Inseam	<b>78</b>	√
10	F	1/2 Thigh (1 cm from crotch)	<b>33</b>	√
11	F2	1/2 Thigh (16cm from crotch)	<b>27</b>	√
12	G	1/2 Knee (30cm from crotch)	<b>23.5</b>	√
13	H	1/2 Calf (50cm from crotch)	<b>21</b>	√
14	I	1/2 Bottom leg opening	<b>19</b>	√
15	I2	Bottom hem stitching height	<b>3.5</b>	√
16	P	Hand pocket opening length	<b>17</b>	√
17	P1	Hand pocket opening width	<b>2</b>	√
18	O	Back pocket opening length	<b>14</b>	-1/2
19	O1	Back pocket height	<b>0.5</b>	-1/2
20	R	Back pocket position from waistband	<b>7</b>	-1/2
21	R1	Back pocket position from center rise	<b>6</b>	√

In the report, few are in the allowance and others are as per the measurement.

#### 4.6 Project Demo:



**Figure 10:** Garment on the dummy.

### 4.7 PO Sheet:

*Chef Works, Inc. 12325 Kerran St Poway CA 92064 Ph: (800) 372-6621 Fax: (858) 643-5614		<b>PURCHASE ORDER: 217332</b>		Date Apr 18, 2025		Page 1 of 1															
<b>Vendor Address:</b> EXCEL WINNER TRADING LTD. (BANG) ATTN: ARIFUL ISLAM HOUSE #366/1 (2ND FL) ROAD #6 BARIDHARA, DHAKA BANGLADESH		<b>Ship To:</b> Chef Works 12325 Kerran St Poway, CA, 92064 USA																			
<b>Reference</b> 6/26 SEP (BCSZ009 NAV) **incl. 5x		<b>Sales Order Number</b>		<b>SHIPPING METHOD:</b> ONGRND																	
<b>Vendor Item Number</b> BCSZ009-NAV COAT-ESS-MDN-SP RINGFIELD-S/S /		<b>SIZE GRID</b> <table border="1"> <tr> <td><b>XS</b> 190</td> <td><b>S</b> 500</td> <td><b>M</b> 1,340</td> <td><b>L</b> 1,520</td> <td><b>XL</b> 700</td> <td><b>2XL</b> 250</td> </tr> <tr> <td><b>3XL</b> 200</td> <td><b>4XL</b> 100</td> <td><b>5XL</b> 200</td> <td></td> <td></td> <td></td> </tr> </table>				<b>XS</b> 190	<b>S</b> 500	<b>M</b> 1,340	<b>L</b> 1,520	<b>XL</b> 700	<b>2XL</b> 250	<b>3XL</b> 200	<b>4XL</b> 100	<b>5XL</b> 200				<b>QTY</b> 5,000	<b>UOM</b> Ea.	<b>Unit Cost</b> 5.17	<b>Extended Amt</b> 25,850.00
<b>XS</b> 190	<b>S</b> 500	<b>M</b> 1,340	<b>L</b> 1,520	<b>XL</b> 700	<b>2XL</b> 250																
<b>3XL</b> 200	<b>4XL</b> 100	<b>5XL</b> 200																			
		<b>TOTAL QTY:</b>				5,000															
<b>Special Instructions</b>		<table border="1"> <tr> <td> <b>Subtotal:</b> </td> <td>25,850.00</td> </tr> <tr> <td> <b>Total tax:</b> </td> <td>0.00</td> </tr> <tr> <td> <b>TOTAL Purchase Order</b> </td> <td>25,850.00</td> </tr> </table>						<b>Subtotal:</b>	25,850.00	<b>Total tax:</b>	0.00	<b>TOTAL Purchase Order</b>	25,850.00								
<b>Subtotal:</b>	25,850.00																				
<b>Total tax:</b>	0.00																				
<b>TOTAL Purchase Order</b>	25,850.00																				
<small>                     Chef Works, Inc. is a federal contractor which complies fully with Executive Order 11246, as amended, Section 503 of the Rehabilitation Act of 1973, as amended, and the Vietnam Era Veterans Readjustment Assistance Act of 1974, as amended. Chef Works' suppliers and contractors (including subcontractors), unless exempted, agree to adhere to the above stated regulations.                 </small>																					

Table 5: PO sheet

## 4.8 Result and Discussion:

Finally, I have submitted the final year design project along with the testing report. The measured GSM of the fabric is 245, which meets the project requirements. Based on the fabric inspection, the material was graded as A-grade. Additionally, the measurements of the final product closely match those specified in the measurement sheet, ensuring that the garment fits the dummy properly

## 4.9 Summary:

In this chapter, I have presented the testing report data to demonstrate that I maintained the required quality standards throughout the project. I made every effort to produce a complete and high-quality garment in our laboratory, with all tests performed in-house.

# Chapter 5: Social Ethics

## 5.1 Introduction

In this chapter, I carefully discuss Professional Responsibilities, Health and Safety, as well as Socio-cultural and Environmental Considerations. My goal is to ensure that my product aligns with societal expectations while upholding ethical principles and promoting environmental sustainability.

## 5.2 Ethical principles and professional commitment involvement

In this product development and choosing the design, I am trying to remember my social ethics and principles. There is a huge impact of it on my product design. In my country, I do not widely use Western style. Because all our people are religious. So, in my product. Again, the cost of the product is not so high that most of the people cannot effort it. Furthermore, the product i am developed for men's. And they can feel confident and comfortable at the same time.

## 5.3 Impact of the project on the environment and sustainability

For this project, the twill fabric is made using 100% cotton yarn, which contains 2% elastane. Thus, we focus on Sustainable Cities and Communities if we wish to include it in the SDGs. Waste management is a major issue right now. even for discarded cotton clothing. Thus, producers gather their spent cotton products, recycle them into yarn, and then blend them in small amounts with newly manufactured cotton yarn. thus, high percentages have the potential to reduce the fabric's strength. Furthermore, dying yarn requires less energy, chemicals, and dye than dying clothing. In this way, we want to make a positive impact on the future.

## 5.4 Summary

My product, the design of it will match our social concerns and an environment-sustainable product

## Chapter 6: Conclusions

### 6.1 References

- <https://www.onlineclothingstudy.com>, how to use 4-point system for knits.html.
- <https://www.onlineclothingstudy.com>, how-to-calculate-gsm-of-fabric.html.