

STUDY OF POWER FACTOR IMPROVEMENT

**A Project and Thesis submitted in partial fulfillment of the requirements for
the Award of Degree of
Bachelor of Science in Electrical and Electronic Engineering**

Submitted By

Md. Mehedi Hasan ID: 151-33-2483

Md. Aurangajeb ID: 151-33-2460

Md. Nishat Jaman ID: 151-33-2336

Supervised by

Dr. A K M Alamgir

Associate Professor

Department of EEE



**DEPARTMENT OF ELECTRICAL AND ELECTRONIC ENGINEERING
FACULTY OF ENGINEERING
DAFFODIL INTERNATIONAL UNIVERSITY**

September 2018

Certification

This is to certify that this project and thesis entitled “**Power Factor Improvement**” is done by the following students under my direct supervision and this work has been carried out by them in the laboratories of the Department of Electrical and Electronic Engineering under the Faculty of Engineering of Daffodil International University in partial fulfillment of the requirements for the degree of Bachelor of Science in Electrical and Electronic Engineering. The presentation of the work was held on 20 September 2018.

Signature of Supervisor

Signature of Candidates

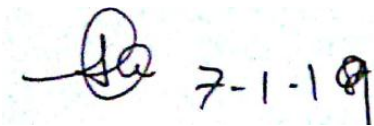

Dr. A K M Alamgir

Associate Professor

Department of EEE

Faculty of Engineering

Daffodil International University

Name: Md. Mehedi Hasan
ID: 151-33-2483

Name: Md. Aurangajeb
ID: 151-33-2460

Name: Md. Nishat Jaman
ID: 151-33-2336

The project and thesis entitled “Power Factor Improvement” submitted by **Md. Mehedi Hasan, ID: 151-33-2483; Md. Aurangajeb, ID: 151-33-2460; Md. Nishat Jaman, ID: 151-33-2336** Session: **Spring 2015** has been accepted as satisfactory in partial fulfillment of the requirements for the degree of Bachelor of Science in Electrical and Electronic Engineering on 25 October 2018.

BOARD OF EXAMINERS

Dr.
Professor
Department of EEE, DIU

Chairman

Dr.
Professor
Department of EEE, DIU

External Member

Dr.
Professor
Department of EEE, DIU

Internal Member

Dedicated to
Our Parents
&
Teachers

CONTENTS

List of Tables	Viii
List of Figures	Viii
List of Abbreviations	X
List of Symbols	Xi
Acknowledgment	Xiii
Abstract	Xiv

Chapter 1: INTRODUCTION	1-23
--------------------------------	-------------

1	Introduction	1
1.1	Power System Definition, Structure, Function	2
1.2	Structure and Function	3
1.3	Generating Stations	3
1.4	Equipment's of Generation Stations	7
1.5	Power Scenario of Bangladesh	9
1.6	Transmission System	11
	1.6.1 Comparison of DC and AC Transmission	12
	1.6.2 Typical AC Power Transmission System	14
	1.6.3 Different Types of Transmission System	14
	1.6.4 Overview of Different Types of Transmission System	16
1.7	Distribution System	20
1.8	Performance of Power System	21
	1.8.1 Voltage Regulation	21
	1.8.2 Efficiency	22

Chapter 2: POWE FACTOR	24-30
2.1	Definition Of Power Factor 24
2.2	Function Of Power Factor on Efficiency 26
2.3	Disadvantage Of Low Power Factor 28
2.4	Caused Of Low Power Factor 30
Chapter 3: POWER FACTOR IMPROVEMENT	31-37
3.1	Introduction 31
3.2	Power Factor Improvement Process 31
3.2.1	Fixed Capacitor 31
3.2.2	Synchronous Condenser 33
3.2.3	Phase Advancer 34
3.2.4	Automatic Capacitor Bank 34
3.3	Power Factor Graph In Various Circuit 35
3.4	Relationship Of Capacitor With Power Factor 36
Chapter 4: Power Factor Data Analysis	38-51
4.1	Introduction 38
4.2	Importance of HIGH power Factor 38
4.3	Economical View of Power Factor 39
4.4	Most Economical Power Factor When KW Demand is Constant 40
4.5	Data Analysis 40

Chapter 5: Power Factor Improvement Equipment	52-55
5.1 Introduction	52
5.2 Primary Equipment	52
5.3 Power and Higher Efficiency	52
5.4 Secondary Equipment	53
Chapter 6: Conclusion	56
6.1 Introduction	56
6.2 Future Scope	56
References	57

LIST OF TABLES

Table #	Table Caption	Page #
1	Present installed generation capacity (MW) as on 11 Sepetember'18	10
2	Power factor and voltage regulation	41
3	Power factor and efficiency	42
4	Power factor and capacitance	44
5	Power factor and kVAR	46
6	Power factor and cost	47
7	Power factor and KVAR	49
8	Power factor and combined capacitance	50

LIST OF FIGURES

Figure #	Figure Caption	Page #
1.1	Basic Structure of AC power system	2
1.2	A typical power system	3
1.3	A basic figure of steam power plant	4
1.4	A basic figure of hydroelectric power plant	5
1.5	A basic figure of diesel power plant	6
1.6	A basic figure of nuclear power plant	6
1.7	Alternator	7
1.8	Generator	7
1.9	A gas turbine	8
1.10	Transformer	9
1.11	Power generation capacity of Bangladesh in the month of September'18	11
1.12	Basic structure of DC power system	12
1.13	Basic structure of AC power system	13
1.14	Single phase two wires AC	16
1.15	Single phase three wires AC	16
1.16	Single phase two wire with midpoint earthed AC	17
1.17	Two phase three wires AC	17

1.18	Two phase four wires AC	17
1.19	Three phase three wires AC	18
1.20	Three phase four wires AC	18
1.21	Two wires DC	18
1.22	Two wire with midpoint earthed DC	19
1.23	Three wires DC	19
1.24	Distribution system	20
2.1	Power triangle	24
2.2	Angle of power factor	25
3.1	Capacitor connected with 3 phase load	32
3.2	Fixed capacitor	32
3.3	Synchronous condenser connected with 3 phase load	33
3.4	Synchronous condenser	33
3.5	Phase advancer	34
3.6	Automatic Capacitor Bank	35
3.7	Power factor graph in various circuit	35
4.1	Diagram of poor and good power factor	39
4.2	Power factor vs Voltage Regulation Curve	42
4.3	Power factor vs Efficiency Curve	43
4.4	Untitled	43
4.5	Power factor vs Capacitor Curve	45
4.6	Power factor vs Reactive Power (kVAR) Curve	46
4.7	Power factor vs Cost Curve	47
4.8	Untitled	48
4.9	Power factor vs kVAR Curve	50
4.10	Power Factor vs Combined Capacitance Curve	51
5.1	SynQor's power factor correction module	53
5.2	Secondary equipment	54
5.3	Automatic capacitor bank	55

LIST OF ABBREVIATIONS

AC	Alternating Current
DC	Direct Current
EMF	Electromotive Force
KW	Kilo Watt
MW	Mega Watt
kVA	Kilo Volt Ampere
kVAR	Kilo Volt Ampere Reactive
VA	Volt Ampere
W	Watt
PF	Power Factor
PFC	Power Factor Correction
SMPS	Switched Mode Power Supply
BPDB	Bangladesh Power Development Board
APSCL	Ashuganj Power Station Company Limited
EGCB	Electricity Generation Company of Bangladesh
NWPGCL	Northwest Power Generation Company Limited
RPCL	Rural Power Company Limited
IPPs	Independent Power Producers
SIPPs	Small Independent Power Producers
HVDC	High Voltage Direct Current

FPGA	Field-Programmable Gate Array
KV	Kilo Volt
SS	Sub Station
DS	Distribution Sub-station

LIST OF SYMBOLS

P	Power
ρ	Resistivity of conductor material
l	Length of the conductor
J	Current density of the conductor
V	Volt
ϕ	Angle of power factor
I	Current
V_m	Maximum voltage
E	E.M.F
Z	Impedance
S	Apparent Power
f	Frequency

This page is intentionally left blank

ACKNOWLEDGEMENT

All praises go to Allah, the Almighty, for the successful completion of this Thesis and fulfillment of our dream into reality. However, thanks and gratitude are also due to the following persons for their continuous support in completing this thesis and in preparing this report.

First of all, we would like to express our sincere appreciation, heartfelt gratitude and cordial thanks to our thesis supervisor, **Dr. Engr. A K M Alamgir, Associate Professor, Department of EEE Faculty of Engineering (FE)**, Daffodil International University, Bangladesh for his invaluable instructions, continuous guidance, constructive criticisms and thoughtful advice during pursuing this thesis and preparation of this report.

Special thanks are extended to our fellow classmates of the Department of Electrical and Electronics Engineering, Daffodil International University, Bangladesh for their helping hand, continuous support and cooperation during this thesis.

Finally, we proudly acknowledges the great sacrifices, good wishes, moral support, fruitful advice, inspirations and encouragements from our family members, relatives and friends which help us to finish the thesis successfully.

ABSTRACT

Demanding electricity is gradually increasing day by day and we are facing boundaries to meet up the demands although. Now we want electricity in each and every sectors. As been being a development country our electricity demand has been raised at a higher rate for developing purposes. In this circumstances, we have to learn the proper use of this scare resource of electricity. Electricity and efficiency related to each other. Everyone wants to use energy in an efficient way. So the term power factor plays an important role in this case. We hardly realize that we are wasting a part of energy every day due to lagging power factor of the inductive load we use. Now-a-days it is a great concern of power Engineers to compensate this loss by the improvement of power factor. There are many methods of power factor correction have been proposed. In this thesis paper, power factor improvement process is described and provided some data analysis of power factor. Power factor is the ratio of real power and apparent power. This definition is mathematically represented as kW/kVA where kW is active power and kVA is apparent power (active + reactive). Reactive power is the non-working power generated by the magnetic and inductive load to generate magnetic flux. The increase in reactive power increase the apparent power so the power factor will decrease. Low PF will cause the industry to meet high demand thus making it less efficient. The main aim of this study is how to increasing the current power factor and what are the way or process. Power factor compensation contribute to reduction in current-dependent losses and increase energy efficiency while expanding the reliability of planning for future energy network. As technology develops, the gradual cost and efficiency penalty should reduce.

CHAPTER 1

INTRODUCTION

1. INTRODUCTION

Most of the electrical energy which used in our daily life is the form of alternative current. This is the approximate consumptions of our daily uses. Thus alternative current is the most usable forms of electricity which is generated, transmitted and distributed. The way of our consumption dimension is basically called as 'load' which is plugged by various kinds of electrical appliances. This load could be varied as resistive load, capacitive load and inductive load. So the fact of power factor comes into our mind in this purpose. Power factor is an energy perception that is linked to power flow in electrical system.

In particular, electrical systems consist of resistors, inductors and capacitors. The inductive devices are driven by the electromagnetic field. Because these inductive loads need true power and reactive power to do work. Most of the loads are which we used such as electric generators, motor, transformers, arc welders, ceiling fan and wireless cellphone charger are inductive in nature. The inductive loads which are provided the power factor is called lagging power factor, or less than 100 percent is based upon the ratio of power factor. Low power factor highly wasting of active power which results in additional losses throughout the entire process of power utilization. So the thought cross our mind is that how this inductive load could be economically beneficial. In most commercial and industrial facilities, most electrical equipment acts as a resistance or inductor.

As the low power factor is both non-profitable in power sector and financial sector. To sustain the economic friendly utilization and make sure the best use of scare resource of power, we must make sure we have the power factor as close as possible to the unit.

1.1 Power System Definition, Structure, Function

The power system is a network which consists of generation stations, electric power transmission system and distribution system. So power system has three separate parts- generation, transmission and distribution.

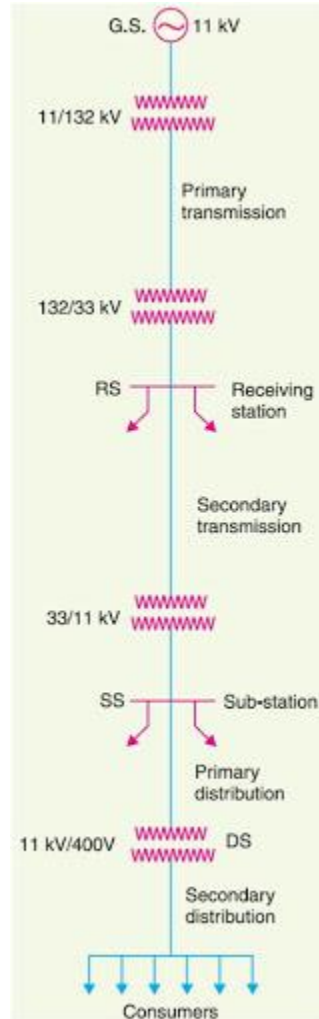

Fig 1.1 Basic Structure of AC power system

The place where electricity generated is known as generating stations or power plants. Power plants are basically located in the remote area. So that peoples are stay out of danger or any harm. Generating station consists of some equipment's such as synchronous generator, motor, transformer, circuit breaker, conductor, etc. After that the generated electricity is transmitted through transmission line. The transformer is used for the purpose of step up and step down

power. And finally we got the electricity in our every step. In sum, this whole system is power system.

1.2 Structure and Function

The basic structure of power system is shown in figure (1.2) below.

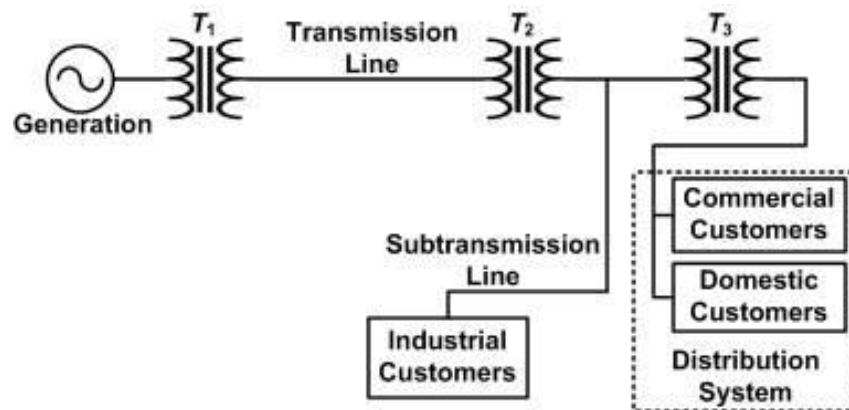

Fig. 1.2 A typical power system.

This complicated system subdivided into the following sub-systems. The subsystems of the power system are explained below in details.

1.3 Generating station

In generating station different form of energy converted into electrical energy. This form of energy is known as fuel. Depends on this fuel the generating stations are classified into four power plants.

- i. Steam power plant
- ii. Hydroelectric power plant
- iii. Diesel power plant
- iv. Nuclear power plant

Steam Power Plant: In steam power plant heat is converted into electrical energy. Electricity is generated through some arrangement like boiler, steam turbine, condenser and alternator. This is the most common type of power plant because the fuel is quite cheap and has a lower initial cost

compared to other power plants. It has very few limitations like polluting the atmosphere due to the large amount of smoke and gases. By the combustion of fuel steam is produced in the boiler. Then the steam goes through a steam turbine and condenser. The condenser condenses the boiler and feeds it to the boiler again.

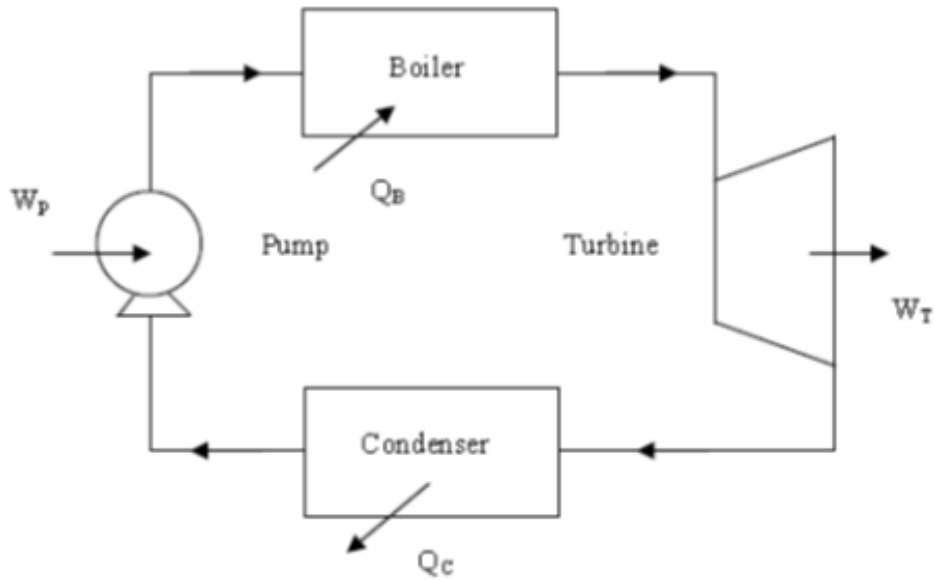

Fig. 1.3 A basic figure of steam power plant.

The alternator is driven by a steam turbine and produces electricity. The alternator converts mechanical energy into electrical energy, and that is the basic process of electricity generation in a steam power plant.

Hydroelectric Power Plant: A hydroelectric power plant is the most economical power plant because of the availability of water. This power plant utilizes the potential energy of water and generates electricity. Hydroelectric power plants are basically located in hilly areas so that the kinetic energy of water and hydro turbines work properly. It has some basic structures needed to generate electricity like a reservoir, dam, water turbine, and alternator.

The technology behind hydro power is quite simple, but the major challenge is to bring the water under control. Hydro power plants need high capital costs, but they require small running charges.

The basic figure of the hydroelectric power plant is shown in Figure 1.4. Basically the dam is built through a river or a lake and is placed after the reservoir. Then the water go to the power house through surge tank, valve house and penstock. From the reservoir, Pressure tunnel brought water to valve house. Valve house located at the start of penstock which is huge pipe. Penstock could be steel or concrete, totally depends on water head.

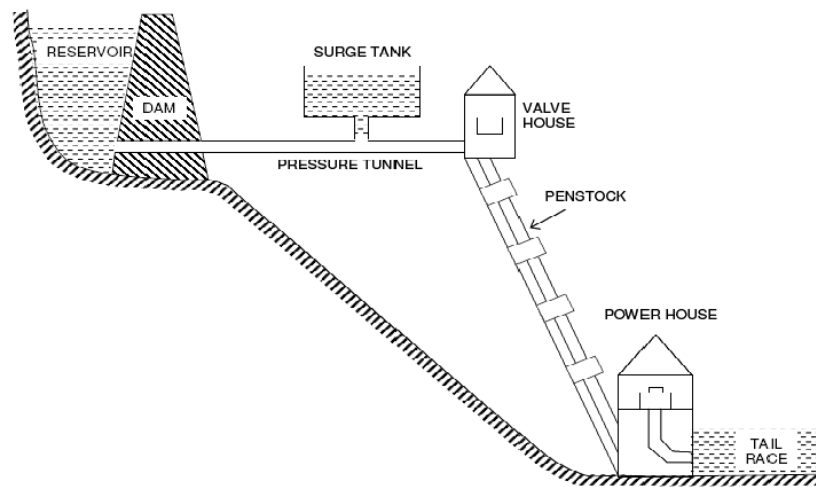

Fig. 1.4 A basic figure of hydroelectric power plant.

Water is taken to the power house through this penstock. In the power house water force let the turbine be rotated and turbine actuates the alternator. Alternator thus converts mechanical energy into electrical energy.

Diesel Power Plant: In the diesel plant, diesel engine is used as a main engine and generates electricity. This power plant requires less space and water for cooling. The working function is very simple in this power plant. Inside the engine diesel burns and produce mechanical energy. Combustion inside the engine act as the working fluid. Then the alternator converts this energy to electrical energy. The disadvantage of this plant is generates small power and maintenance charge is high.

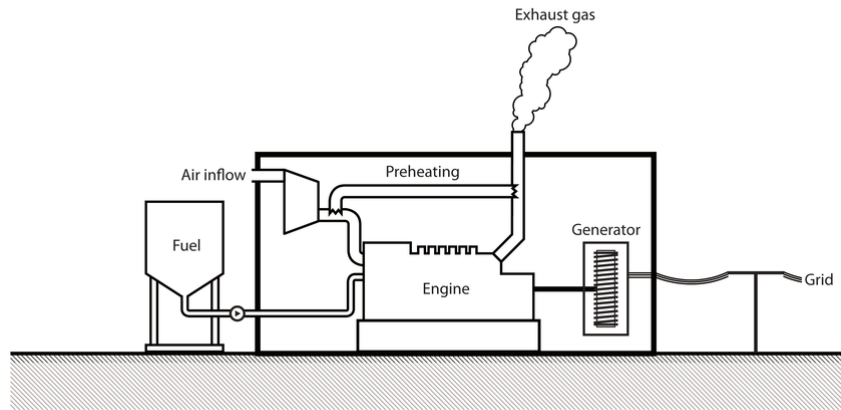

Fig. 1.5 A basic figure of diesel power plant.

Nuclear Power Plant: Nuclear power plant, electricity generated from the nuclear energy. It is the most expensive power plant over all of them. But the efficiency is excellent compared with fuel of other power plant.

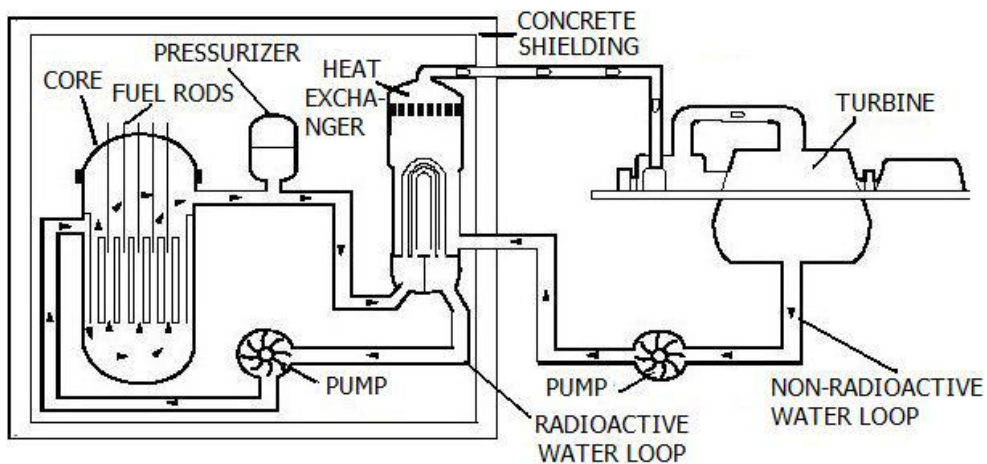

Fig. 1.6 A basic figure of nuclear power plant.

In this power plant, heavy components like Uranium (U^{235}) or Thorium (Th^{232}) is used as the fuel. This fuel occurs fission reaction and release huge amount of heat energy. This whole reaction happens in the reactor. Inside the reactor control rods control the reaction. The control rods are basically made of cadmium because cadmium is a strong neutron absorber. The heat passes to the heat exchanger through the refrigerant and, after the release of heat, the refrigerant is returned to the reactor. Produced steam in the heat exchanger rotates steam turbine. Turbine helps the alternator to rotate and alternator produce electricity.

1.4 Equipment's of Generation Station

Alternator: Alternator is kind of generator which produce alternating current by converting mechanical energy to electrical energy. Any AC electrical generator known as alternator. Alternator works on the basis of Faraday law, a conductor is generated electromotive force (EMF) by moving in magnetic field. This EMF reverses its polarity when it moves under magnetic poles of opposite polarity.

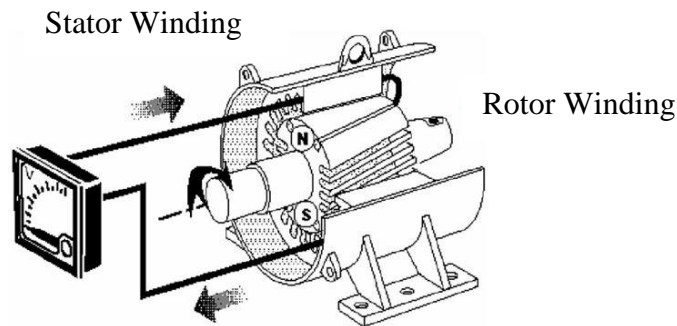

Fig. 1.7 Alternator.

It has two main parts one is rotor and another one is stator. Rotor is the rotating magnet and stator is the set of conductor which is wounded is coil on an iron core. Rotor winding used by the alternators which permits the control of the alternator's induced voltage by varying the current in the rotor field winding.

Generator: The generator consists of two main parts: the rotary parts and the stationary parts. As their name indicates, the moving section is called rotary parts or rotor and the stator is stationary parts.



Fig. 1.8 Generator.

The outer surface of the rotor is shielded by electromagnets made of wire wound around an iron core. The internal surface of the stator consists of copper coils. The electrons in the copper windings vibrate during the rotation of rotor inside the stator. The movement of rotor helps to produce electricity.

Turbine: The prime portion of a turbine is the displacement box that starts spinning when the water hits the turbine blades. The energy of falling water used in hydraulic turbine and in under pressure, mechanical energy is produced. By a metal shaft, the turbine is directly attached to the generator. The shaft transmits its rotational movement.

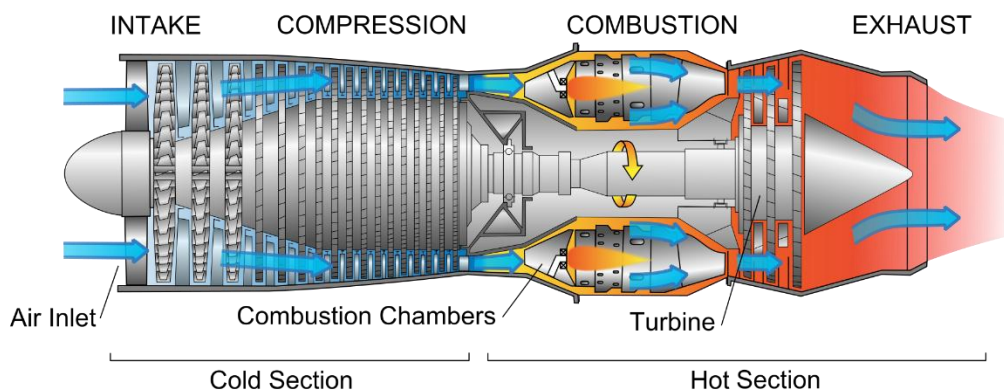

Fig. 1.9 A gas turbine.

The types of turbine depends on the flow of water and the head which define that will be installed in the generating station. In Quebec, the Francis turbine is the most used turbine, which is more suitable for medium and high head changes and large capacities of water. The propeller turbines are preferable for the low heads, as well as the variations of these turbines (Kaplan) with blades that can be adjusted according to the available flow rate.

- 1 to 15 meters: Propeller turbine
- 1 to 30 meters: Kaplan turbine
- 10 to 300 meters: Francis turbine

Transformer: This is an electrical device which increases the voltage level of the alternating current generated by the generator. There are two coils present in the transformer. In the primary

coil, the low voltage electric current enters and the secondary coil, where high voltage electricity is generated and moves towards the transmission or distribution lines.

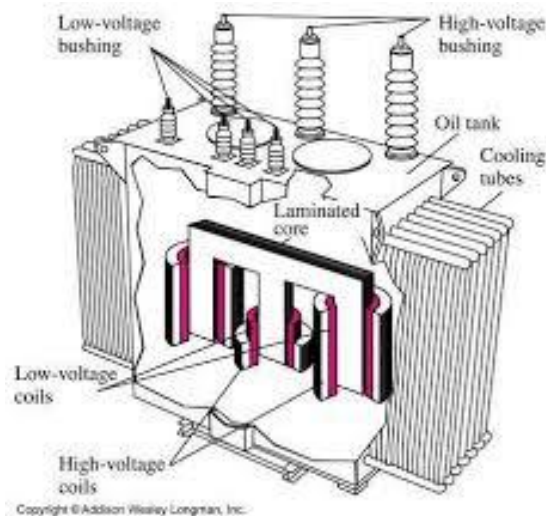

Fig. 1.10 Transformer.

Transmission of high voltage electricity is very easy and suffers less losses for long distance transmission. There is also a transformer which reduces the voltage level of the transmission and distribution systems. In this type of transformer, high voltage electricity provide in the primary coil and the secondary coil reduces the voltage level. [4]

1.5 Bangladesh Power Scenario

The History of Bangladesh's Power Sector is one of persistence hard work and success. We have been growing up technologically and also producing Power. The achievements have been driven by a single minded dedication, Public-privet sector collaboration in power sector. In Bangladesh, Natural gas is the leading and the economical source of energy. It is an important source of energy that accounts for 75 percentage of the commercial energy of the country which is likely to be depleted by the year 2020. In 1990-1991 the installed capacity stood at 2350MW. In 2016-2017 the installed capacity has increased to over 13500MW. Today the installed capacity has increased to over 16193MW.

In working to achieve its electrification goals, Bangladesh is adopting flexible power solutions alongside traditional grid connectivity with 10% of off-grid power. For this reason the electrification rate have increased –In 1990-The rate was 8.5% , In 2009-The rate was 47%, Today-The rate is around 90%-Privet-Public Partnership (Government contribution 56% &

Privet contribution 46% of financial support) actually helped to raise the electrification rate. In our country the present Generation is around 10000MW though our capacity is still 13500MW. But day by day power demand is rapidly expanding for increasing urbanization and the massive amount of industrialization.

Table: 1 Present Installed Generation Capacity (MW) as on 11 September, 2018 [10]	
Public Sector	Installed Generation Capacity (MW)
BPDB	5266
APSCL	1444
EGCB	839
NWPGCL	1211
RPCL	77
BPDB-RPCL JV	149
Subtotal	8986 (53%)
Private Sector	
IPPs	4802
SIPPs (BPDB)	99
SIPPs (REB)	251
15 YR. Rental	169
3/5 YR. Rental	1576
Power Import	1160
Subtotal	8057 (47%)
TOTAL	17,043 *

Including Captive Power & Renewable Energy Total Installed Capacity (17,043 + 2,800+290) = 20,133 MW. Total Renewable capacity is 290MW and the hydro can only can produced 230MW. Present Government have already taken some future project to increase the electrical capacity . They have made a plan to make the capacity 24000MW within the year of 2021, to make the capacity 30000MW in the year of 2030 and the 60000MW in the year of 2041.

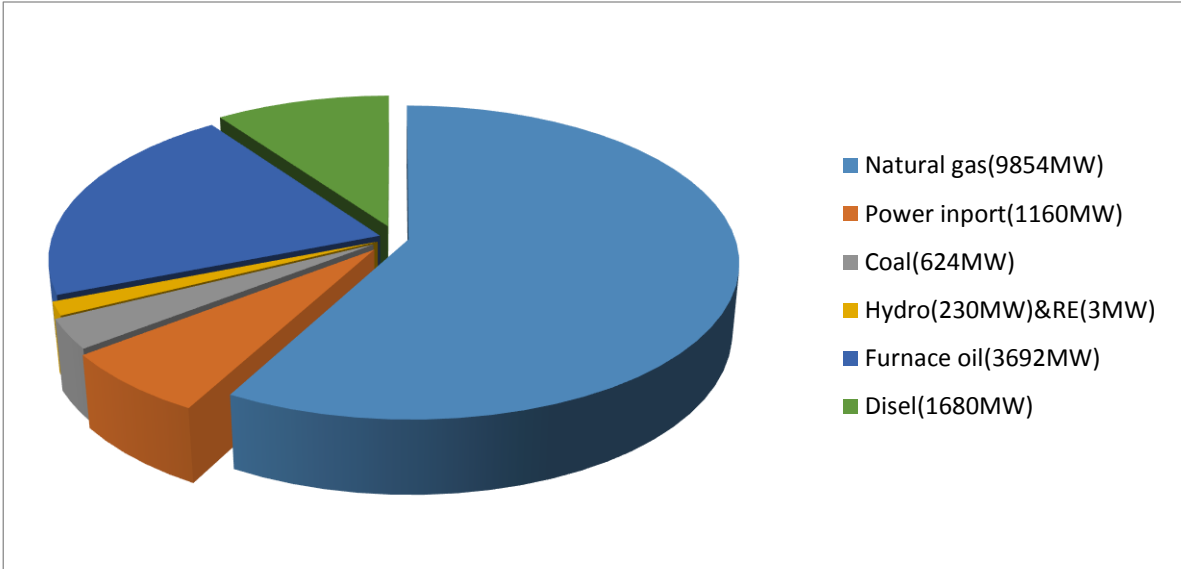

Figure 1.11: Power generation capacity of Bangladesh in the month of September 2018

1.6 Transmission System

It is the second division of power system. From generating station to distribution the whole system is known as transmission system. The generating station is normally situated far away from the locality. Transmission system helps to transmit this energy to the consumers. This system can be AC or DC form. Alternating current (AC) form is using now for its popularity and conveniences, especially HVDC (High voltage direct current) gaining its possibility day by day. An important part of this system is transformers, which are helping to increase voltage level to make long distance transmission easier. Now-a-days, 3-phase, 3-wire AC system is universally accepted and economically beneficial for generation and transmission.

Advantages of high transmission voltage

- Reduces volume of conductor material:
Volume of the conductor material = $\frac{3P\rho l^2}{VV^2\cos^2\phi}$
- Increases transmission efficiency:
Transmission efficiency = $\left[1 - \frac{\sqrt{3}J\rho l}{V\cos\phi}\right]$ approx.
- Decreases percentage line drop:
%age line drop = $\frac{J\rho l}{V} \times 100$

1.6.1 Comparison of DC and AC Transmission

DC transmission

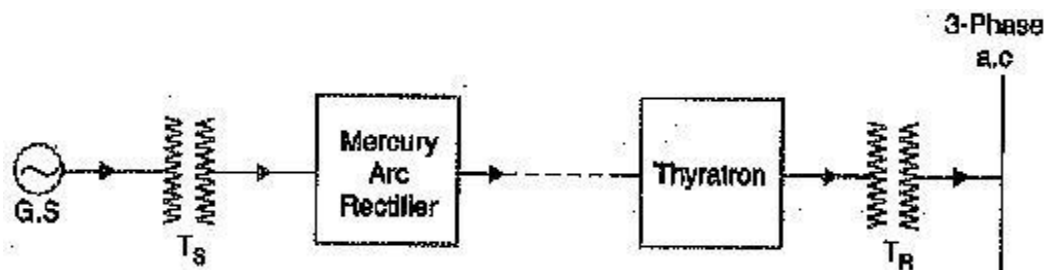

Fig 1.12 Basic Structure of DC power system.

Advantages

- Requires only two conductors.
- There is no inductance, capacitance, phase difference and surge problem.
- Better voltage regulation.
- No skin effect.
- DC line requires less insulation.
- Less corona loss and reduced interference with communication circuit.
- The high voltage DC transmission is free from dielectric losses.
- No stability problem and synchronizing difficulties.

Disadvantages

- Electric power cannot be generated at high DC voltage due to communication problems.
- DC voltage cannot be stepped up.
- The switches and circuit breakers have their own limitations.

AC Transmission

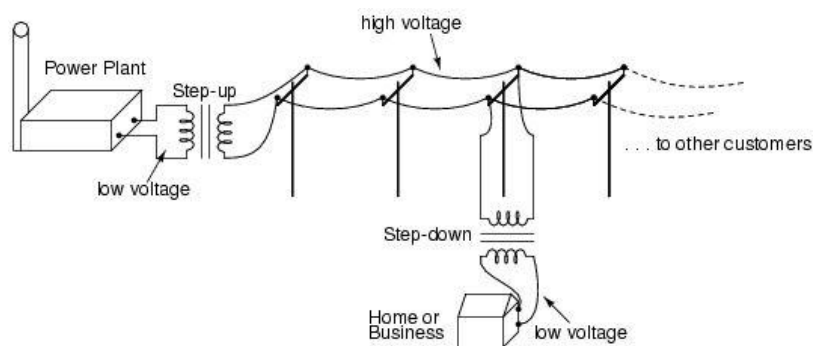

Fig 1.13 Basic Structure of AC power system.

Advantages

- The power can be generated at high voltages.
- The maintenance of AC substation is easy and cheaper.
- The AC voltage can be stepped up or stepped down by transformers.

Disadvantages

- Requires more copper than DC.
- Due to skin effect in the AC system the effective resistance of line is increased.
- AC line has capacitance therefore there is continuous loss of power due to charging current even when the line is open.

1.6.2 Typical AC Power Transmission System

Electricity is normally generated at 11 kV in a power plant. While in some cases, the power can be generated at 33 kV. This generation voltage increases to 132kV, 220kV or 400kV. The increase in the voltage level depends on the distance at which the power is transmitted. The longer the distance, the greater the level of voltage. Increasing the voltage reduces the loss of I^2R in the transmission of power. When the voltage is increased, the current is reduced by a relative amount, so that the power remains constant and therefore the loss of I^2R is also reduced. This stage is called primary transmission.

The voltage is reduced to a 33kV or 66kV receiving station. Secondary transmission lines emerge from this receiving station to connect the substations located near the loading centers. [2]

1.6.3 Different Types of Transmission Systems

We have already learned that, for the transmission of electricity, a 3-wire 3-phase system is universally accepted. The different possible system of transmission are: [1]

1. Single phase AC system
 - i. single phase, two wires
 - ii. single phase, three wires
 - iii. single phase, two wires with midpoint earthed
2. Two phase AC system
 - i. two-phase, three wires
 - ii. two-phase, four wires
3. Three phase AC system
 - i. three-phase, three wires
 - ii. three-phase, four wires
4. DC system
 - i. DC two wires
 - ii. DC three wires
 - iii. DC two wires with midpoint earthed

From the possible previous energy transmission system, it is difficult to say which the best system is, unless a comparison method is adopted until it is adopted. Now, the cost of driver material is one of the most important costs in a system. Obviously, the best system for energy transmission is that for which the volume of conductive material required is minimal.

As we already know, transmission lines are used to transmit electricity from one place to another. This transmitting starts at step up transformer in the form of alternating current. We can divided transmission lines on the basis of conductor material, safety and efficient for our system into three types. [6]

1. Overhead lines
2. Underground lines
3. Sub transmission lines

Overhead Lines: This lines are dealing with very high voltage, like above 100 KV. Most of the long distance lines are overhead line. In this system, the insulation between the conductors, in the supports or in the intermediate points, is always provided by a correct spacing of the conductors. Therefore, electric shocks cannot occur between drivers. However, the insulation must be provided between the conductor and the support structure. Therefore, the maximum voltage is between the conductor and the ground.

Underground Lines: The overpopulated areas where overhead lines seems not to be fit in, underground line could easily be used there. Underground lines are costly but safe. Also some disadvantages, if there any causes any problem it seems hard to deal with, though the chances are rare of being problematic. In this system, the main voltage in the insulation is between the conductors. Therefore, the comparison of the system in this case must be made on the basis of the maximum potential difference between the conductors.

Sub transmission Lines: Carry lower voltages (26 kV - 69 kV) to distribution stations, and can be overhead or underground.

1.6.4 Overview of difference type of transmission system

Single phase two wire AC: In the single-phase 2-wire AC system, one conductor is grounded. The maximum voltage between the conductors is V_m , so the value r.m.s of the voltage between them is $V_m/\sqrt{2}$.

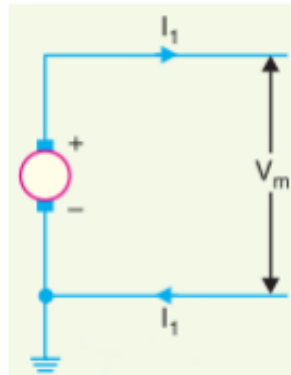

Fig 1.14 Single phase two wire.

Single phase three wire AC: The system consists of two external and neutral cables taken from the midpoint of the phase winding. The maximum voltage between the cables is $2V_m$. The value r.m.s of the voltage between the conductors is $= \sqrt{2} V_m$

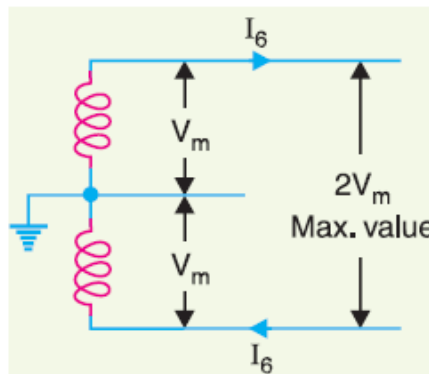

Fig 1.15 Single phase three wire.

When the load is balanced then the neutral wire current is zero.

Single phase, two wires with midpoint earthed AC: The two cables have equal and opposite voltages with respect to earth (V_m). The maximum voltage between the cables is $2V_m$. The value r.m.s of the voltage between the conductor is $=\sqrt{2}V_m$.

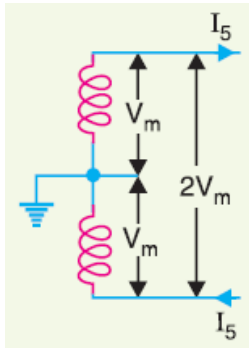

Fig 1.16 Single phase, two wires with midpoint earthed.

Two phase, three wires AC: The third or neutral wire is taken from the junction of two-phase windings whose voltages are in quadrature with each other. The r.m.s voltage between outgoing conductor and neutral is $V_m/\sqrt{2}$.

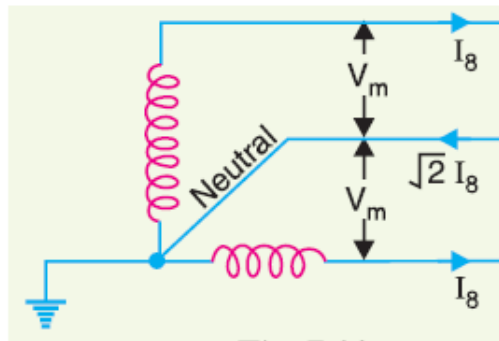

Fig 1.17 Two phase, three wires.

Two-phase, four wires AC: The four wires are taken from the ends of the two phase windings and the midpoints of the two windings are connected together. This system can be considered as two independent single phase systems.

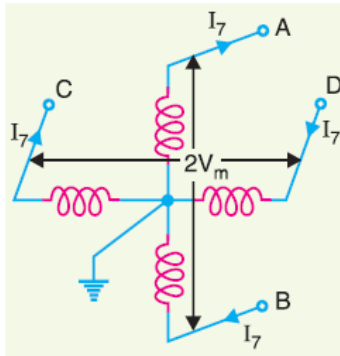

Fig 1.18 Two-phase, four wires.

Three-phase, three wires AC: The 3-phase, 3-wire system may be star or delta connected. The neutral point is earthed. The r.m.s voltage per phase = $\frac{V_m}{\sqrt{2}}$ and power transmitted per phase = $\frac{P}{3}$.

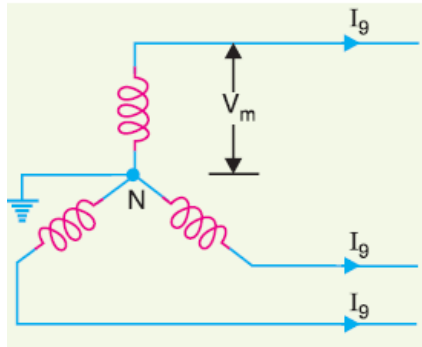

Fig 1.19 Three-phase, three wires.

Three-phase, four wires AC: In this system, neutral wire is taken from the neutral point. If the loads are balanced, then current through the neutral wire is zero.

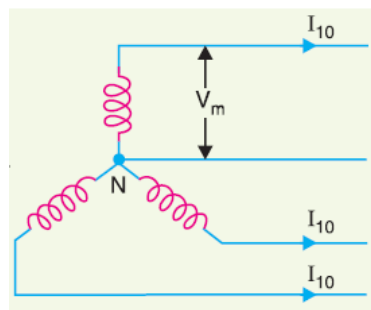

Fig 1.20 Three-phase, four wires.

DC two wire: In the 2-wire DC system, one is the output or positive cable and the other is the return or negative cable. The load is connected between the two cables.

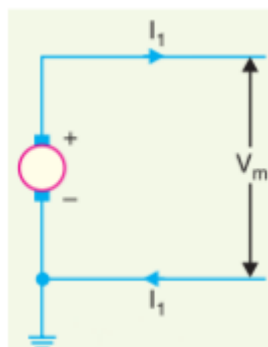

Fig 1.21 DC two wire.

DC two-wire with mid-point earthed: In the 2-wire DC system with midpoint connected to earth; The maximum voltage between any conductor and ground is V_m , so that the maximum voltage between the conductors is $2V_m$.

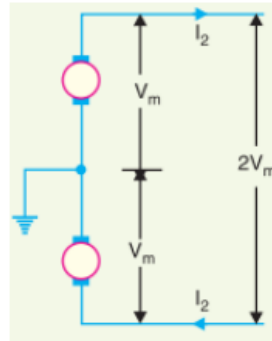

Fig 1.22 DC two-wire with mid-point earthed.

DC three-wires: In a 3-wire DC system, there are two external cables and an intermediate or neutral cable that is grounded at the upper end. If the load is stable; the current in the neutral wire is zero.

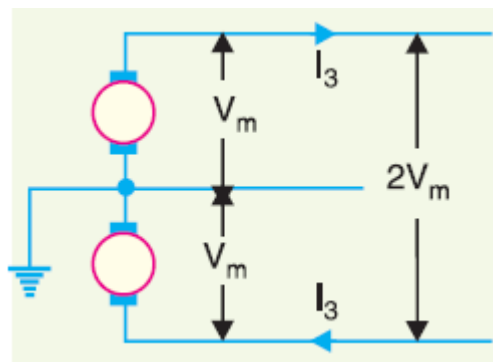

Fig 1.23 DC three-wires.

Elements of a Transmission Line

The principle elements of a high-voltage transmission line are:

Conductors: Usually, three for a single circuit line and six for a dual circuit line. The usual material is made of aluminum covered with steel.

Step-up and Step-down transformers: Respectively at the end of sending and receiving. The use of transformers allows the transmission of high efficiency power.

Line insulators: They mechanically support the line conductors and isolate them electrically from the ground.

Support: Which are usually steel towers and provide support to the conductors.

Protecting devices: Such as ground wires, lightning rods, circuit breakers, relays, etc. They guarantee a satisfactory service of the transmission line.

Voltage regulating device: This keeps the voltage at the receiving end within the allowed limits.

1.7 Distribution System

The part of power system which uses to distribute power for the local usages is usually known as distribution system. In general, it moves electric power from generation station to load.

Usually it consist of three parts, which are feeders, distributors and service mains.

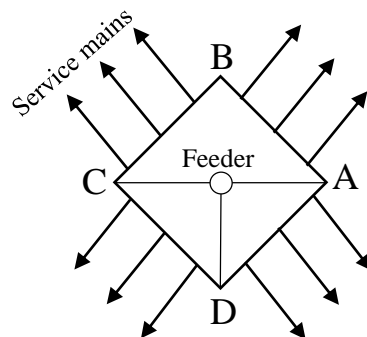

Fig 1.24 Distribution system.

Feeders: A power supply is a conductor that has a large current-carrying capacity. Connect the substation to the area where the energy will be delivered.

Distributor: A distributor is a conductor from which tapping is used to supply consumers. In Figure 1.24, AB, BC, CD and DA are the distributors.

Service Mains: It is a short wire which connects the distributors to the user's terminals.

Now-a-days AC is one of the convenient form of electrical energy. AC is more efficient than DC as it has more flexibility to get require voltage by stepping up and down with the help of transformer. The AC distribution system is classified into two division.

- i. Primary Distribution System
- ii. Secondary Distribution System

Primary Distribution System: In the substation (SS), the voltage is reduced to 33 KV at 11 KV. The 11 KV line runs along the sides of the important highway to the city. Because of economic thinking, this system is implemented through a 3- phase 3- wire system. The most used primary distribution voltages are 11KV, 6.6KV and 3.3KV.

Secondary Distribution System: In this distribution system, voltage operate at the consumer's level. The electric power from primary distribution line (11 KV) is delivered to Distribution Sub-stations (DS), located near the users, and step down to 400 V. On account of economical thought, this system is carried out by 3-phase 4-wire system.

1.8 Performance of Power System

In old days, small power stations were built to supply electricity for lighting and heating purpose because of there was a little demand of electricity. By dint of modern civilization, use of electrical energy is increased comprehensively. Performance of power system is achieved by increasing the power generation and uninterrupted power supply while minimizing the losses and economically beneficial. So, while studying the performance of power system, it is desirable to determine its voltage regulation and efficiency.

1.8.1 Voltage Regulation

In electrical engineering, particularly in electrical engineering, voltage regulation describes the ability of a system to provide near-constant voltage over a wide range of load conditions. The voltage regulation is the difference between the secondary no load voltage of the transformer and the full load voltage with respect to its full load voltage. Basically, every transformer has a voltage drop due to its impedance (resistive, inductive properties). Therefore, at different voltages and load conditions, this internal voltage drop across the transformer windings will vary and affect the final secondary output voltage.

Suppose, an electrical power transformer is open circuited, means load is not connected with secondary terminals. In this situation, the secondary terminal voltage of the transformer will be

its secondary induced e.m.f E_2 . When the full load is connected to the secondary terminals of the transformer, the rated current I_2 flows through the secondary circuit and a voltage drop occurs. In this situation, the primary winding will also draw the equivalent full load current from the source. The voltage drop in the secondary is $I_2 Z_2$ where, Z_2 is the secondary impedance of the transformer.

Now if at this loading condition, any one measures the voltage between secondary terminals, he or she will get voltage V_2 across load terminals which is obviously less than no load secondary voltage E_2 and this is because of $I_2 Z_2$ voltage drop in the transformer.

Expression of Voltage Regulation of Transformer, represented in percentage, is

$$\text{Voltage regulation}(\%) = \frac{E_2 - V_2}{V_2} \times 100\%$$

1.8.2 Efficiency

In general term, efficiency means the ration between output energy and input energy and expressed as percentage. It is very important term of any system because we can get the overall overview of any system by calculating its efficiency. In power system various types of losses counts from generating station to the consumers. Our main focus is to decrease the losses and increasing the efficiency. The power obtained at the receiving end of a transmission system is generally lower than the final sending power due to losses. That's why saving energy is more efficient than generating energy.

The relationship between the final reception power and the final sending power of a transmission system is known as the energy efficiency of the system.

$$\begin{aligned} \text{\%age efficiency, } \eta &= \frac{\text{sending end power}}{\text{recieving end power}} \times 100 \\ &= \frac{V_R I_R \cos\theta_R}{V_S I_S \cos\theta_S} \times 100 \end{aligned}$$

Where,

$V_R =$ Receiving end voltage

$V_S =$ Sending end voltage

$I_R =$ Receiving end current

$I_S =$ Sending end current

$\cos\theta_R =$ Receiving end power factor

$\cos\theta_S =$ Sending end power factor

CHAPTER 2

POWER FACTOR

2.1 Definition of Power Factor

The cosine of angle between voltage and current in an AC circuit is known as power factor. How incoming power is being used in a system is power factor.

$$\text{Power factor} = \cos\phi = \text{cosine of angle between } V \text{ and } I$$

In AC circuit, the ratio between real power and apparent power is called power factor. Real power is used to do work and apparent power is supplied to the circuit. Real power (KW) is a kind of power which stimulates the equipment and results in useful and productive work. It is also called Actual Power, Active Power or Working Power. Reactive Power (kVAR) is a power required for some special equipment's (e.g. transformers, motors and relays) to create a magnetic field and enable real work to be done. Apparent Power (kVA) is both the vector sum of Real Power (kW) and Reactive Power (kVAR) and also the total power which supplied through the power mains what is required to produce the relevant amount of real power for the load.

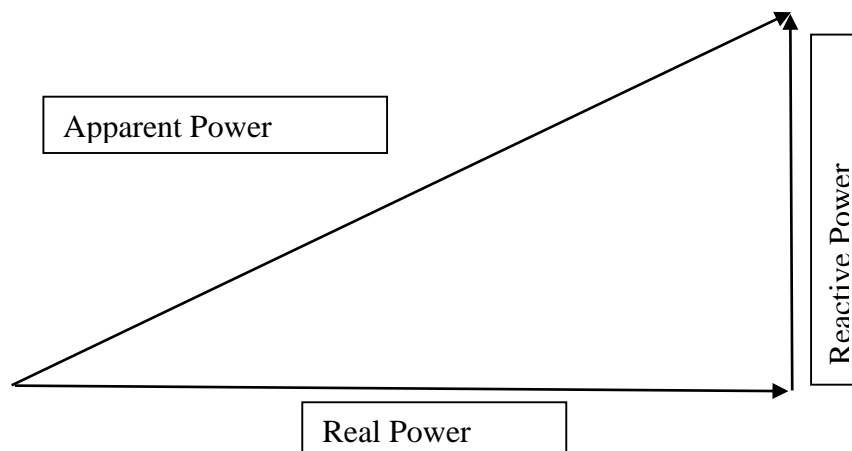

Fig. 2.1 Power Triangle.

$$\text{Power Factor} = \frac{\text{Active Power}}{\text{Apparant Power}} = \frac{kW}{kVA}$$

In an AC circuit, there is a phase difference ϕ between voltage and current. The term $\cos\phi$ is named the power factor of the circuit. In an inductive loop, the current is left behind and the power factor is known as lagging. However, in a capacitive circuit, current leads to voltage and it is said that the power factor is leading.

$$\cos\phi = \frac{kW}{kVA}$$

Consider a capacitive circuit taking a leading current I from supply voltage V ; the angle of lead being ϕ . The phasor diagram of the circuit is shown in figure 2.2.

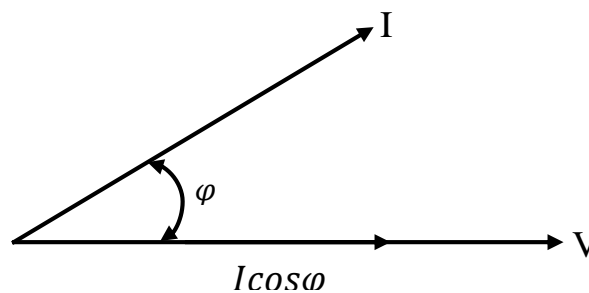

Fig. 2.2 Angle of Power Factor

It should be noted that the value of the power factor can never be higher than 1.

If the circuit has a power factor of 0.5 and the current leads the voltage, we usually write PF as 0.5 leading. Sometimes the power factor is expressed as a percentage. Therefore, the main power factor of 0.5 can be expressed as a 50% leading. The main power factor means that the current drives the voltage and the delayed power factor means that the current has delayed the voltage. The lagging reactive power is responsible for the low power factor. If the circuit current falls behind the voltage, the extracted reactive power is known as a lagging reactive power. However, if the circuit current leads to voltage, the reactive power is known as the main reactive power. If a device that takes the main reactive power is connected in parallel with the load, then the delayed reactive power of the load will be partially neutralized, thus improving the load power factor. [1]

2.2 Function of Power Factor on Efficiency

Efficiency is the ratio of the energy output of an appliance to the energy input, expressed as a percentage.

$$\eta = \frac{P_{out}}{P_{in}}$$

Output power, $P_{dc} = V_{dc} \times I_{dc}$ (W)

Apparent Power, $S = V_{rms} \times I_{rms}$ (VA)

By definition, the power factor is the ratio between real power and apparent power, in which apparent power is the product of effective voltage and effective current. Only when the power factor is equal to 1, the product volt-ampere is equal to the real power.

$$PF = \frac{P}{S}$$

The power factor is a measure of reducing energy costs, which is not a true measure of energy savings. Improving the power factor can reduce energy costs if the end user is subject to power factor costs from the service company. Users with electricity service rates based solely on energy use, with a free application (such as residential users and small commercial users), do not normally benefit from power factor correction measures. The end-user power factor correction is applied to avoid public service rates due to the low power factor and also to reduce the demand for end-user transformers and generators to release capacity. Electric companies, to reduce the losses of their system, encourage energy users to consume energy efficiently by defining their charges based on certain parameters. A common electrical load is for a low power factor. Better described and understood when examining the components of an electrical system, the power factor is the ratio between kilowatt (kW) and kilovolt-ampere (kVA). The total electric power kVA has two components: real power kW and reactive power kilovolt-ampere reactive (kVAR)

— Mathematically described as:

$$kVA_2 = kW_2 + kVAR_2$$

And

$$\text{Power factor} = \frac{kW}{kVA}$$

Many loads of commercial and industrial installations are motors, inductive loads that require inductive reactive power. The capacitors provide electrically reactive power in the opposite direction to the inductive reactive power. The inductive KVAR can be reduced or canceled by adding capacitive kVAR. Unity PF, or 100% PF, is when kVA = kW. A delayed PF is any PF less than 100%, inductive kVAR and is typical in commercial and industrial plants. The initial PF, capacitive kVAR, is any PF that is greater than 100%. The initial PF is typically an undesirable electrical condition for a number of reasons. The change in the reactive power component has no effect on the actual power required by the load. The reactive power has an effect on the kVA that feeds the load and can cause the load on the generator to be greater than necessary. The fixed capacitors in the main electrical service are a common method for correcting the delayed PF. Installations with large motors can also locate the capacitors in the motors, which helps to reduce the current load of the driver and the transformer to the motor. [3]

Changes to engine design to increase efficiency, reducing losses, may or may not change the power factor. For example, reducing the air gap between the stator and the rotor reduces the "magnetizing current" that the motor draws to maintain the magnetic field through that space. This means less "copper loss" in the winding of the motor through which the current flows and, therefore, greater efficiency. But the power factor will also increase, due to the lower magnetization current. However, a smaller air gap increases the loss of load lost in the engine, which tends to decrease efficiency. To maintain a high efficiency, it is necessary to increase the air space, reducing the power factor. [5]

Taking into account the type of device, energy can "escape" at different points. Electrical losses (I^2R) represent a considerable part of total losses, producing heat in the appliance. Devices with an iron core have losses due to hysteresis, which cause magnetic losses in the iron and losses from parasitic currents, which are electrical losses in the iron core. Induction motors and transformers show significant leakage reactance, which are losses due to inductance. As the current increases, skin effect losses increase greatly in the conductors. Rotating machines also

have rotational losses due to the extreme bearing friction and rotor wind age. Although many appliances are designed for maximum efficiency, so losses can never be eliminated completely.

Since the reactive power does not do any work, PF indicates the percentage of useful energy of the total energy, and is better when it is as close as possible to the unit. A low PF can contribute to low efficiency, higher losses and unnecessary expenses for electrical services. Induction motors require both real and reactive power to operate. Real power (kW) produces work and heat. The reactive power (kVAR) establishes the magnetic field in the motor that allows it to operate. The PF of an engine is lower when the engine is under load and is significantly reduced when the engine load is less than 70%. The best way to keep the PF close to the engine design classification, which is usually 80% to 85% of the PF, is a close motor adjustment to the load.

2.3 Disadvantage of Low Power Factor

The power factor has significant role in AC circuit and power dissipation upon this factor.

$$P = V_L I_L \cos\phi$$

$$I_L = \frac{P}{V_L \cos\phi}$$

For single phase supply

$$P = \sqrt{3} V_L I_L \cos\phi$$

$$I_L = \frac{P}{\sqrt{3} V_L \cos\phi}$$

For three phase supply

From the above equation, the load current is inversely proportional to the power factor. Thus lower the power factor, higher is the load current and vice-versa. In case of Low Power Factor, Current will be increased, and this high current will cause to the following disadvantages.

Large kVA rating of equipment: As we know that almost all electrical machinery (Transformer, Alternator, Switchgears etc.) rated in kVA. The electrical machinery is rated in kVA because the power factor of the load is not known when the machinery is manufactured in the factory.

$$kVA = \frac{kW}{\cos\phi}$$

The smaller the PF, the larger is the *kVA* rating. Therefore, at low PF, *kVA* rating has to be made more, will result in larger size equipment, hence higher cost is required.

Copper Losses: We know that, line losses is directly proportional to the square of Current (I^2). The large current at low PF causes more I^2R losses in all elements of power system and therefore the efficiency of the system is reduced.

Greater Conductor Size and Cost: In case of low power factor, current will be increased, thus, to transmit this high current, we need the larger size of conductor. Also, the cost of large size of conductor will be increased.

Example, an AC motor having input of $15kW$ on full load and the terminal voltage is $250V$. At unity power factor,

$$I_{Full\ Load} = \frac{15000}{250} = 60A$$

If the *power factor* = 0.75 then the *kVA* input is

$$I = \frac{15000}{250 \times 0.75} = 80A$$

If the motor is worked at a low power factor of 0.75, the cross sectional area of the supply cables and motor conductors would have to be based upon a current of 80A.

Poor Voltage Regulation and Large Voltage Drop: A higher current produced a voltage drop in the device. This results in poor voltage regulation.

$$Voltage\ Drop = V = IZ$$

Now in the event of a low power factor, the current increases. Therefore, the greater the current, the greater the voltage drop.

$$Voltage\ Regulation = V.R = \frac{V_{No\ Load} - V_{Full\ Load}}{V_{Full\ Load}}$$

In the case of a low power factor (lagging power factor), a large voltage drop will occur which will cause low voltage regulation. Therefore, maintaining the voltage drop in the specific limit, it is necessary to install additional regulation equipment, ie voltage regulators.

Low Efficiency: In the event of a low power factor, there would be a large voltage drop and large line losses, which would cause the efficiency of the system or equipment to be too low. For a moment, due to the low power factor, there would be large line losses; therefore, the alternator needs a high excitation, so the generation efficiency would be low.

Penalty from Electric Power Supply Company on Low Power factor: Electrical Power Supply Company imposes a penalty of power factor below 0.95 lagging in electric power bill. So you must improve PF above 0.95. [7]

Higher Voltage: In power generation, higher excitation with lower power factor give higher voltages than normally required.

2.4 Caused of Low Power Factor

Low power factor is unwanted from economic standpoint. The normal power factor of a supply system is basically lower than 0.8. The usual reason for the low power factor is because of the inductive load. Most of the AC motors are induction type. The current in the inductive load lag behind the voltage. These motors work at a very small power factor on light load it 0.2 to 0.3 and rises to 0.8 to 0.9 at full load. The power factor is therefore lagging.

The important inductive loads responsible for the low power factor are the three-phase induction motors (which operate at a 0.8 lagging power factor), transformer, arc lamps, electric discharge lamp, industrial heating furnace and welding equipment operate at low lagging power factors.

The load on the power system is changing depends on time. In the morning and evening it rises and low at other times. During low load period, supply voltage is increased which increases the magnetization current. This results in the decreased power factor. [1]

CHAPTER 3

POWER FACTOR IMPROVEMENT

3.1 INTRODUCTION

Power factor is the most important parameter for power system. It has to be under control or it has to be in specific range. High power factor is always preferable for any power system where power factor is needed.

3.2 POWER FACTOR IMPROVEMENT PROCESS

Generally in most of the generating station having power factor between 0.8 and 0.9. But, sometimes it decreases such way that then we have to take certain step to increase this power factor. Power factor is possible to be improved by some of equipment's. The equipment's are:

1. Fixed Capacitor
2. Synchronous Condenser
3. Phase Advancer
4. Automatic Capacitor Bank

3.2.1 Fixed capacitors: The power factor can be improved by connecting the capacitors in parallel with the equipment working with a lagging power factor. This capacitor is generally known as fixed or static capacitor. This equipment induces a leading current and partly or completely neutralizes the lagging reactive element of load current. This increases the load power factor. For three-phase loads, the capacitors can be connected in delta or star parallel with load.

Benefits

- i. They have low losses.
- ii. Require little maintenance because there are no rotating parts.
- iii. They can be installed easily because they are light and do not require a foundation.
- iv. They can work in normal weather conditions.

Disadvantages

- (i) They have a short life of 8-10 years.
- (ii) They are easily damaged if the voltage exceeds the nominal value.
- (iii) Once the capacitors are damaged, their repair is not economic.

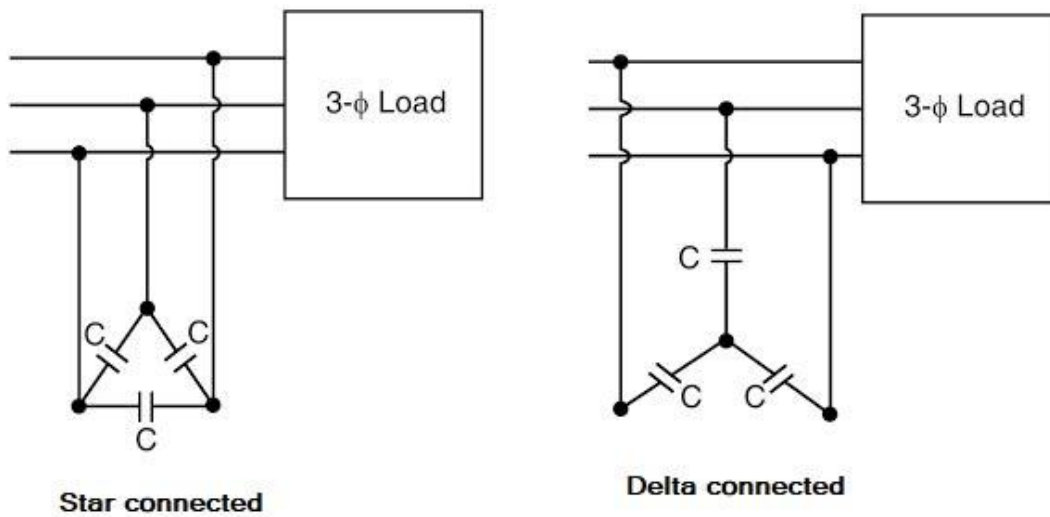

Fig 3.1: Capacitor connected with 3-φ Load



Fig 3.2: Fixed Capacitor

3.2.2 Synchronous Condenser: A synchronous motor takes a main current when it is overexcited and, therefore, behaves like a capacitor. An over-excited synchronous motor that operates without load is known as a synchronous capacitor. When a machine of this type is connected in parallel to the power supply, it takes a leading current which partially neutralizes the reactive component of the charge being delayed. This improves the power factor. They are three-phase synchronous motors without load coupled to their axis. The synchronous motor has the characteristics of operating with any power factor, lagging or unit depending on the excitation. For inductive loads, the synchronous capacitor is connected to the load side and is overexcited. This makes him behave like a condenser. It extracts the delay current from the source or provides the reactive power.

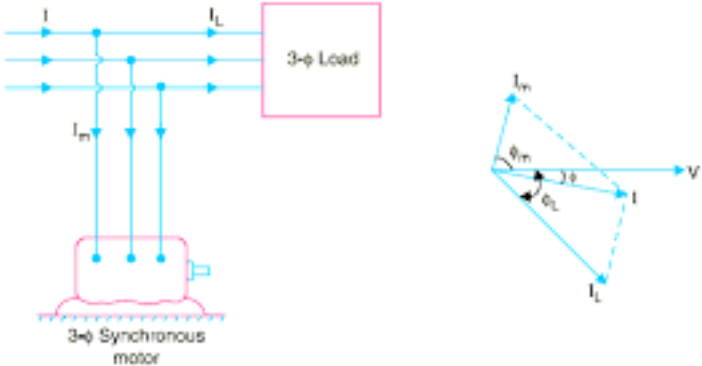

Fig 3.3: Synchronous Condenser connected with 3-φ Load

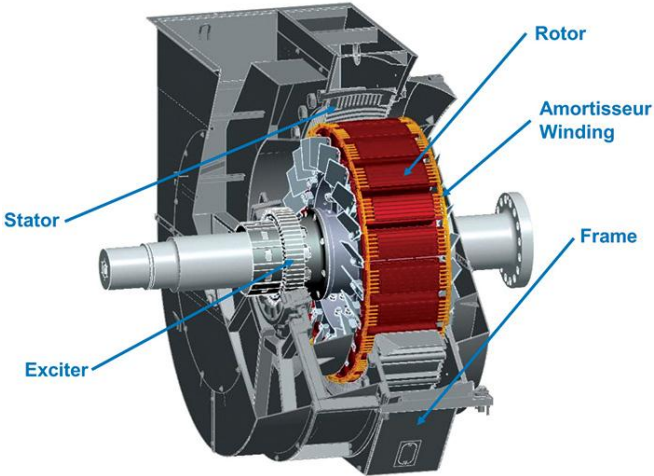

Fig 3.4: Synchronous Condenser

3.2.3 Phase Advancer: This is an AC exciter mainly used to improve pf of induction motor. They are mounted on shaft of the motor and is connected in the rotor circuit of the motor. It improves the power factor by providing the exciting ampere turns to produce required flux at slip frequency. Further if ampere turns are increased, it can be made to operate at leading power factor. Phase feeds are used to improve the power factor of induction motors. The low power factor of an induction motor is due to the fact that the winding of its stator attracts an exciting current which is delayed by 90° above the supply voltage. If it is possible to provide the exciting revolutions of the amplifiers from someone else AC source, then the stator winding will be released from the excitation current and the motor power factor can be improved. This work is done through the phase advance, which is simply AC exciting. The phase advance is mounted on the same axis as the main motor and is connected in the motor rotor circuit. Provides exciting exchangers for the rotor circuit at a slip rate. By providing more amps than necessary, the induction motor can operate with a main power factor such as an over-excited synchronous motor.



Fig 3.5: Phase Advancer

3.2.4 Automatic capacitor banks: Compensation is more-commonly effected by means of an automatically-controlled stepped bank of capacitors. This kind of equipment provides automatic control of compensation, maintaining the power factor within close limits around a selected level. Such equipment is applied at points in an installation where the active-power and/or reactive-power variations are relatively large.



Fig 3.6: Automatic Capacitor Bank

3.3 POWER FACTOR GRAPH IN VARIOUS CIRCUIT

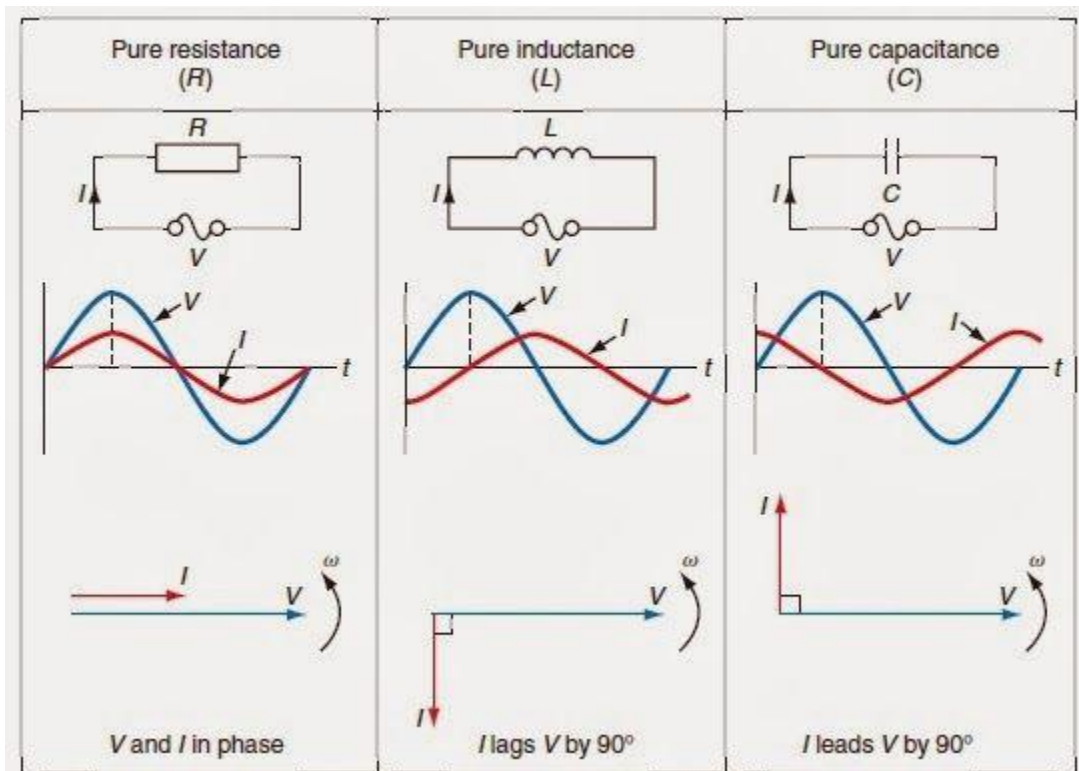

Fig 3.7: Power factor graph in various circuit

3.4 RELATIONSHIP OF CAPACITOR WITH POWER FACTOR

The capacitor is the main component that provides capacitive reactance, which is a negative reactive power. Since, the power factor is the ratio between the real power and the apparent power, in which the apparent power is related to the reactive power and the real power, as shown in the power triangle. As a system most of the power supply has inductive loads, usually only a lagging power factor is produced, so the capacitors are used to compensate by producing a supply current to the load to reduce the lagging current, thus reducing the distance of the phase angle between the power real and apparent power. In general, the power capacitors must be connected to Y in the three-phase power supply. Neutral grounding is essential for the fuses to function in the event of a condenser failure. For a small bank of Y-connected capacitors without a ground connection, a faulty capacitor would not burn the fuse to isolate a faulty capacitor. Any event of this could cause an explosion in the condenser battery. However, isolating the neutral from the Y connection of a capacitor bank has the advantage of reducing harmonics. The method can only be an alternative when the neutral ground connection would cause operational difficulties for a particular installation. In case of insulation failure inside the unit, the phase-to-ground fault can still occur in a capacitor bank connected to Y without a ground connection, even with its own cabinet properly connected to ground. The most effective solution is to insert reactors in series with each group of capacitors connected between the phase cable and the neutral of a three-phase bank. The frequency is standardized at a constant of 50 Hz or 60 Hz; the correction of the power factor is valid as a solution to this fixed network frequency, the only key solution is the addition of a capacitor in derivation to the load. Capacitors are commonly used in many power systems, especially in electronically constructed circuits. Although it is common, therefore, it is less understood by the majority as a more advantageous component for the energy system.

- Release of system capacity.
- Reduction of KVAR generation requirements.
- Reduction of system loss.
- Voltage regulation or improvement connect the capacitor in parallel (shunt) instead of connecting it in series.

The function of shunt power capacitor is to run leading (capacitive) KVARs to an electrical system when and where needed. Lagging (inductive) KVARs perform when there are inductors (coils) exist within electrical (e.g. motor) or electronic (personal computer) equipment, as the amount grows, the increment of inductive KVARs will increase as well, thus the demand of capacitive KVARs to compensate is pretty much required in order to reduce unnecessary lost. The actual capacitor in farads of a capacitor bank can be calculated using the following equation,

$$kVAR = 2\pi fC \times V^2$$

And capacitor current,

$$I_C = \frac{V}{X_C} = 2\pi fC \times V$$

What is the correct energy factor correction for you? You are experiencing...

1. Engine failure
2. Failure of electrical or electronic equipment.
3. Overheating of transformers, switchboards and wiring.
4. Annoying operation of circuit breakers or fuses.
5. Unstable operation of the equipment.
6. Consumption and high costs.

In power sector particularly AC circuit, power factor is very important and plays a vital role in power generation station, sub-station, consumer (industrial consumer) because of its capability of maintaining inductive load. As the value of PF varies from 0 to 1.

CHAPTER 4

POWER FACTOR DATA ANALYSIS

4.1 INTRODUCTION

Poor power factor can be corrected, paradoxically, by adding another load to the circuit drawing an equal and opposite amount of reactive power, to cancel out the effects of the load's inductive reactance. Inductive reactance can only be canceled by capacitive reactance, so we have to add a capacitor in parallel to our example circuit as the additional load. This chapter consist the analysis of power factor, efficiency, kVAR, cost, voltage regulation and capacitance value.

4.2 Importance of HIGH power Factor:

1. To insure the better utilization of electrical machineries. When you use any electrical machinery, you have to insure the maximum utilization of that devices using as possible as low power an
2. High power factor. When you use an electrical device with low PF, it will be consumed more power which is very unnecessary and economically threat for any consumer. So it is very important to use devices with high PF.
3. To minimize the electrical devices size. Basically electrical device such as generator, transformer, inductive motor etc size depend on kVA rating. The greater kVA, the larger size of device. But this kVA is depend on PF. So to minimize the device size, you need to higher PF of that device.
4. To reduce the cost of electricity.
5. To insure the better utilization of conductors.
6. To reduce the loss. With low PF of conductor, I^2R loss will be increased with the extra heat of conductor. High PF fix the current carrying capacity of conductors and minimize the losses and heat of conductors.45% losses can be reduced by using high PF.

Reactive energy, which supplies the magnetic circuits of electrical machines, must be equalized by means of suitable systems, such as batteries or capacitors. Reactive energy compensation equipment can be automatic, fixed or static.

SOCOMEK has developed a range of reliable, secure and high-performance reactive energy compensation equipment that can meet your needs. In particular, they will enable you to:

- Reduce energy bills;
- Eliminate penalty tariffs;
- Maximize efficiency of installations and equipment

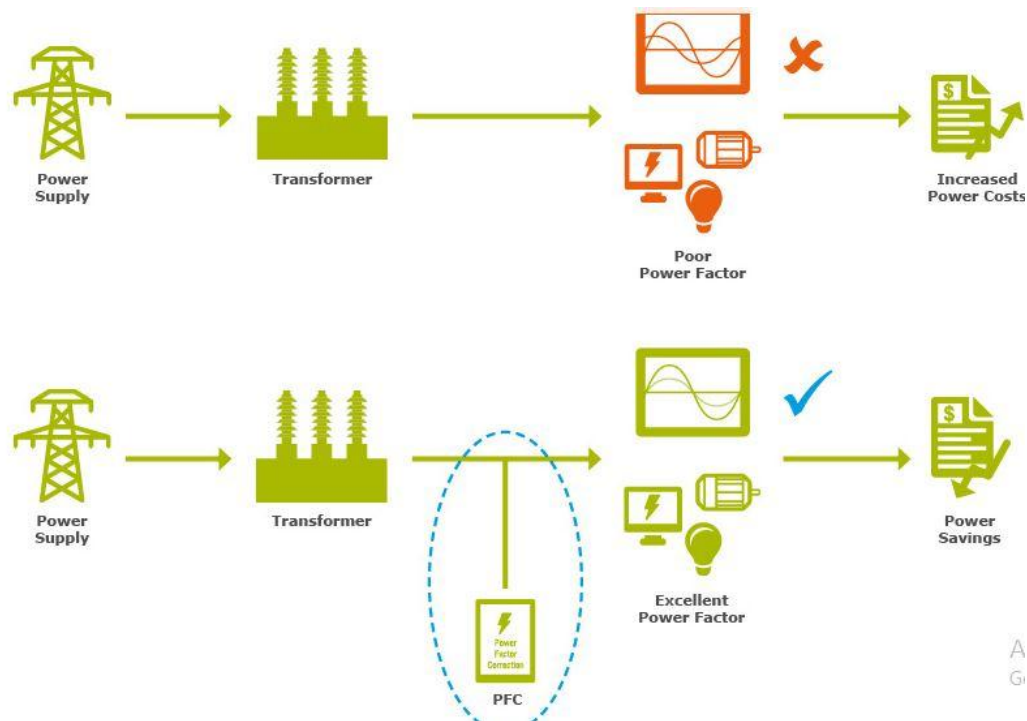

Fig 4.1: Diagram of poor and good power factor

4.3 ECONOMICAL VIEW OF POWER FACTOR

0.96 lagging pf means most of your consumed power is been active power and very less amount of reactive power .This will give the apparent power nearly equal to your active power. Which simply means most of your power is utilized in useful work.

I would say practically 0.96 is also too much as it is too much nearer to 1 .Though unity pf is best in theoretical aspect but in practical unity pf will create a resonance in your power system and this will damage your power system . That is the reason we keep our power factor around 0.8 to 0.95 lag.

4.4 MOST ECONOMICAL POWER FACTOR WHEN KW DEMAND IS CONSTANT:

There is a reduction in maximum KVA demand and then there will be an annual savings over the maximum demand charge if a consumer improves the power factor. However when power factor is improved, it involves capital investment on the power factor correction equipment.

The consumer will incur expenditure every year in the shape of annual interest and depreciation on the investment made over the pf correction equipment. Therefore the net annual savings will be equal to the annual saving in the maximum demand charges minus expenditure incurred on pf correction equipment.

4.5 DATA ANALYSIS

Data analysis has been acquired based on 3- ϕ and single phase load. And various data have been assimilated to clarify the outcome. Here the obtained data is presenting now.

Sample 01: A 3- ϕ line provide 5000 kW and varying power factor from 0.70 to 0.95 lagging. Sending end voltage 22 kV and the resistance and reactance values are respectively 4 Ω and 6 Ω .

From the above information we will find out voltage regulation, efficiency and power factor relation.

Sample Calculation:

Given that,

$$\cos\phi_R = 0.8$$

$$\sin\phi_R = 0.6$$

$$\text{Receiving end voltage per phase, } V_R = \frac{22000}{\sqrt{3}} = 12701.7 \text{ V}$$

$$\text{Impedance per phase, } \vec{Z} = 4 + j6$$

$$\text{Line current, } I = \frac{5000 \times 10^3}{3 \times 12701.7 \times 0.7} = 187.45 \text{ A}$$

$$\vec{I} = 187.45(0.7 - j0.714) = 131.215 - j133.84$$

$$\vec{I} = \vec{V}_R + \vec{I}\vec{Z} = 12701.7 + (131.22 - j133.84) \times (4 + j6) = 14031.88(\text{Real value})$$

$$\text{Voltage regulation} = \frac{V_S - V_R}{V_R} \times 100\% = \frac{14031.88 - 12701.7}{12701.7} \times 100\% = 10.47\%$$

$$\text{Line Loss} = 3I^2R = 3 \times 187.45^2 \times 4 = 421.65 \text{ kW}$$

$$\text{Efficiency, } \eta = \frac{5000}{5000 + 421.65} \times 100\% = 92.22\%$$

By Calculating same way, we got some values. These are given in a table.

Power Factor	Voltage Regulation (%)
0.1	69.44168794
0.2	35.22918482
0.3	24.03609627
0.4	18.37959508
0.5	14.87208572
0.6	12.3988042
0.7	10.47360246
0.8	8.825130552
0.9	7.216406098
1	4.316542908

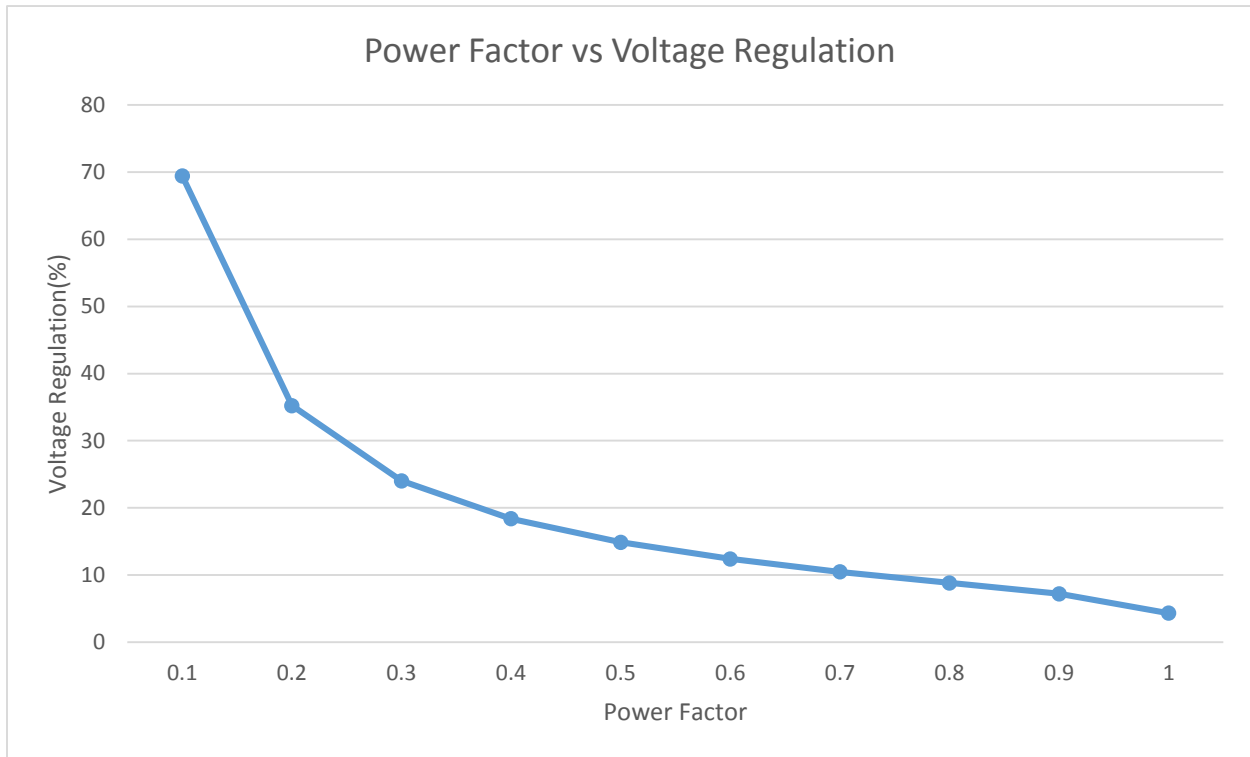

Fig 4.2: Power Factor vs Voltage Regulation Curve

Case Study: From the above graph and table, it easily can be understood that if power factor increases then voltage regulation reduce gradually.

Power Factor	Efficiency (%)
0.1	19.48470209
0.2	49.18699187
0.3	68.53366897
0.4	79.47454844
0.5	85.81560284
0.6	89.70345964
0.7	92.22274071
0.8	93.93498302
0.9	95.14610232
1	96.03174603

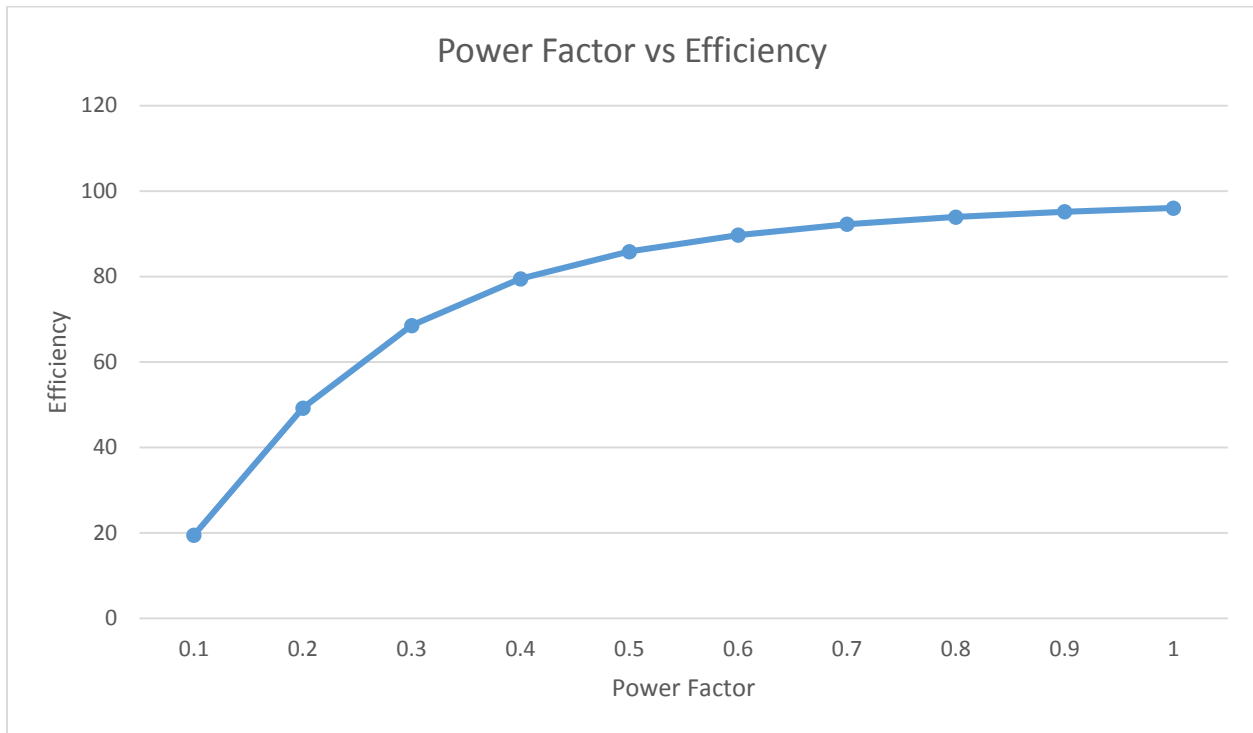

Fig 4.3: Power Factor vs Efficiency Curve

Case Study: From the above graph and table, it easily can be understood that power factor accelerates efficiency.

Sample 02: A single phase motor has connected to 400 V, frequency 50 Hz and current 31.7A having a power factor of 0.7 lagging. Let's find out the capacitance value by varying the power factor with economic standpoint.

Sample Calculation:

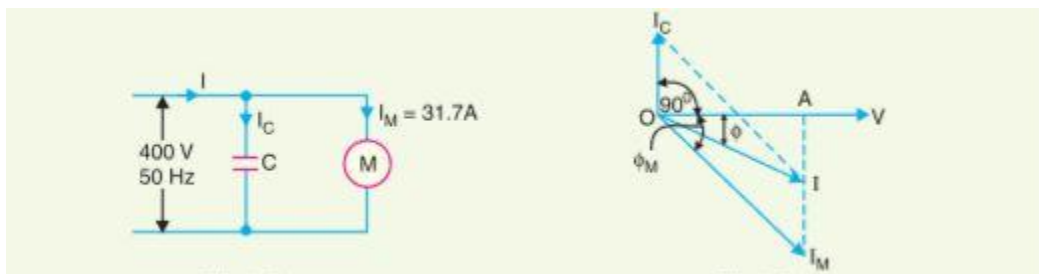

Fig 4.4

Motor Current, $I_M = I_M \cos \varphi_M = 31.7 \times 0.7 = 22.19 \text{ A}$

Active Component of I = $I \cos \varphi = I \times 0.8$

So, Supplied current, $I = \frac{22.19}{0.8} = 27.738$

Reactive Component of $I_M = I_M \sin \varphi_M = 31.7 \times 0.714 = 22.634 \text{ A}$

Reactive Component of I = $I \sin \varphi = 27.738 \times 0.6 = 16.643 \text{ A}$

Capacitor Current, $I_C = \text{Reactive Component of } I_M - \text{Reactive Component of } I$
 $= 22.634 - 16.643 = 5.991 \text{ A}$

But $I_C = \frac{V}{X_C} = 2\pi f C \times V$

So, Capacitor, $C = \frac{5.991}{400 \times 2\pi \times 50} = 47.67 \mu\text{F}$

By Calculating same way, we got some values. These are given in a table.

Power Factor	Capacitance (μF)
0.1	-1576.82
0.2	-684.922
0.3	-381.345
0.4	-224.451
0.5	-125.699
0.6	-55.293
0.7	0
0.8	47.71317
0.9	94.62711
1	180.1497

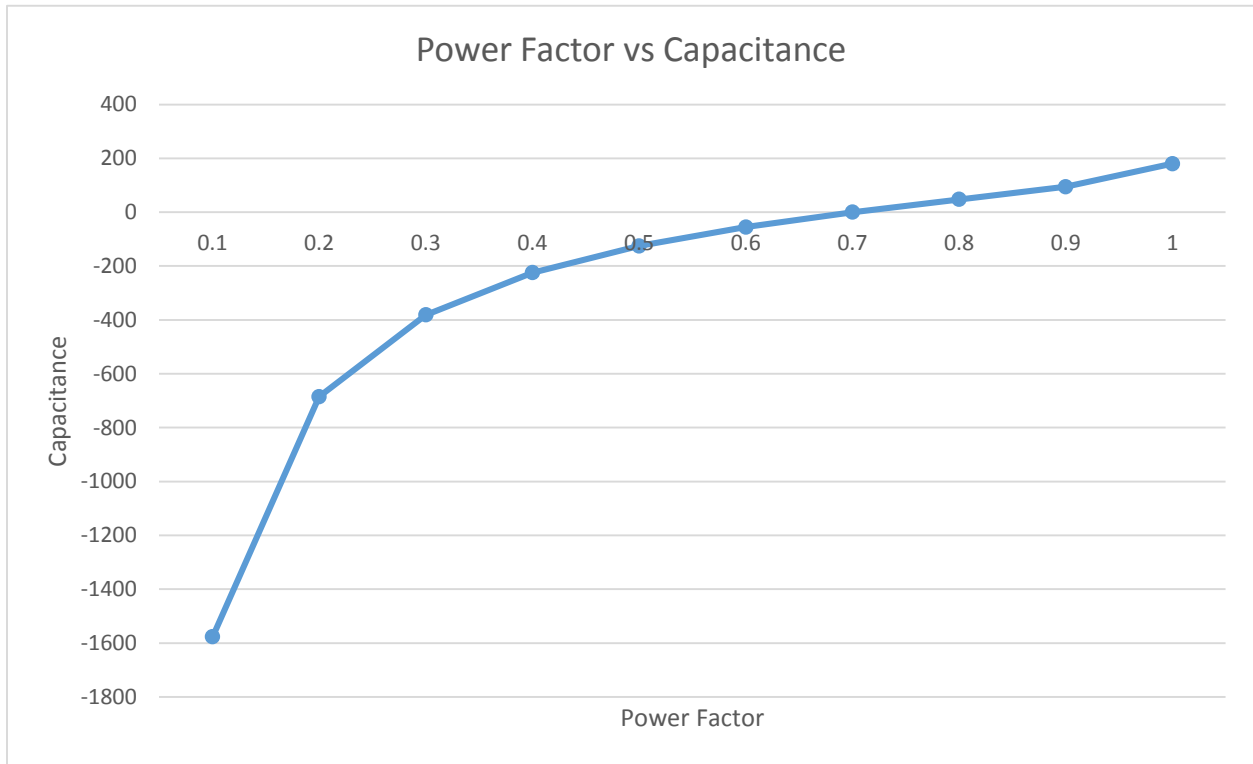

Fig. 4.5: Power Factor Curve vs Capacitance Curve.

Case Study: From the above graph and table, it easily can be understood that power factor increases the value of capacitance.

Now, let's find out relation between power factor and kVAR

We know,

$$kVAR = 2\pi fC \times V^2$$

So, from the above calculation. We can write,

Power Factor	kVAR
0.1	-79.2598
0.2	-34.428
0.3	-19.1685
0.4	-11.2821
0.5	-6.31835
0.6	-2.77934
0.7	0
0.8	2.398331
0.9	4.756488
1	9.055331

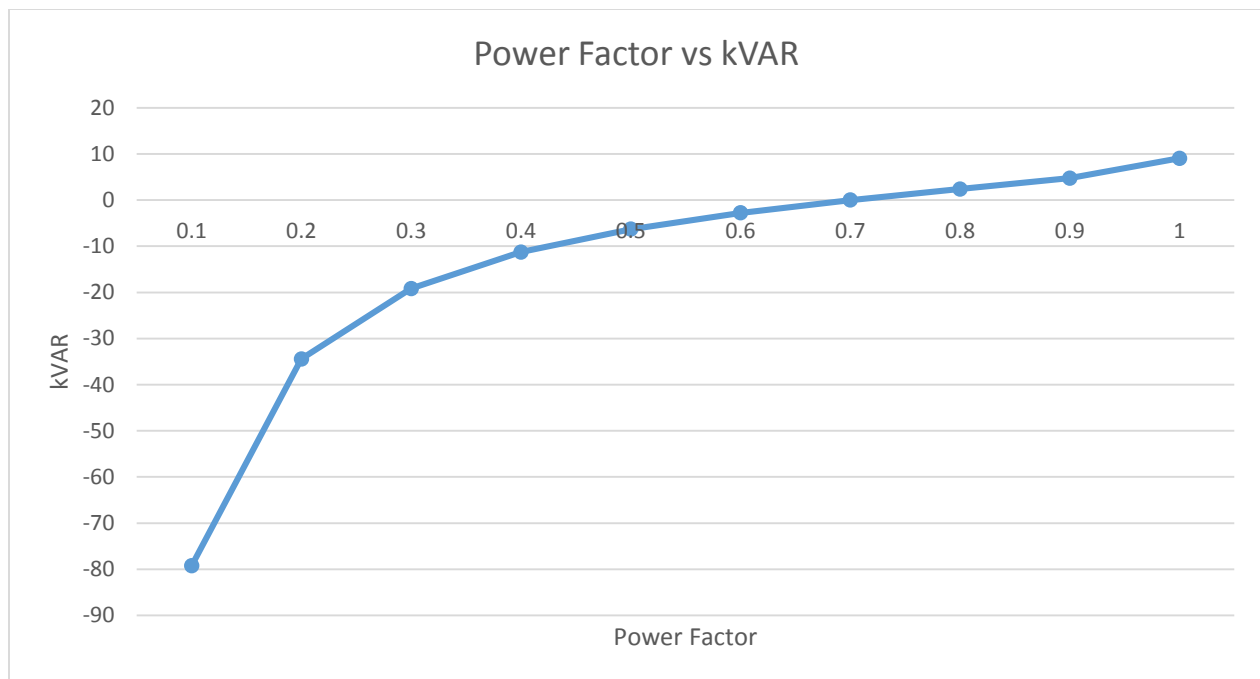

Fig 4.6: Power Factor vs Reactive Power (kVAR) curve

Case Study: From the above graph and table, it easily can be understood that power factor increases the kVAR.

Sample 03: A factory running with a maximum demand of 175 kW charged at 70 Tk per kVA per year. Let's find out the equipment cost with varying the range of power factor under economic standpoint.

Sample Calculation:

Maximum demand charges, $a = 70 \text{ Tk/kVA/year}$

Expense, $b = a\sqrt{1 - (\cos\phi)^2} = 70 \sqrt{1 - (0.1)^2} = 69.649 \text{ Tk/kVAR/year}$

By Calculating same way, we got some values. These are given in a table.

Power Factor	Cost of Capacitance
0.1	69.64912
0.2	68.58571
0.3	66.77574
0.4	64.15606
0.5	60.62178
0.6	56
0.7	49.99
0.8	42
0.9	30.51229
1	0

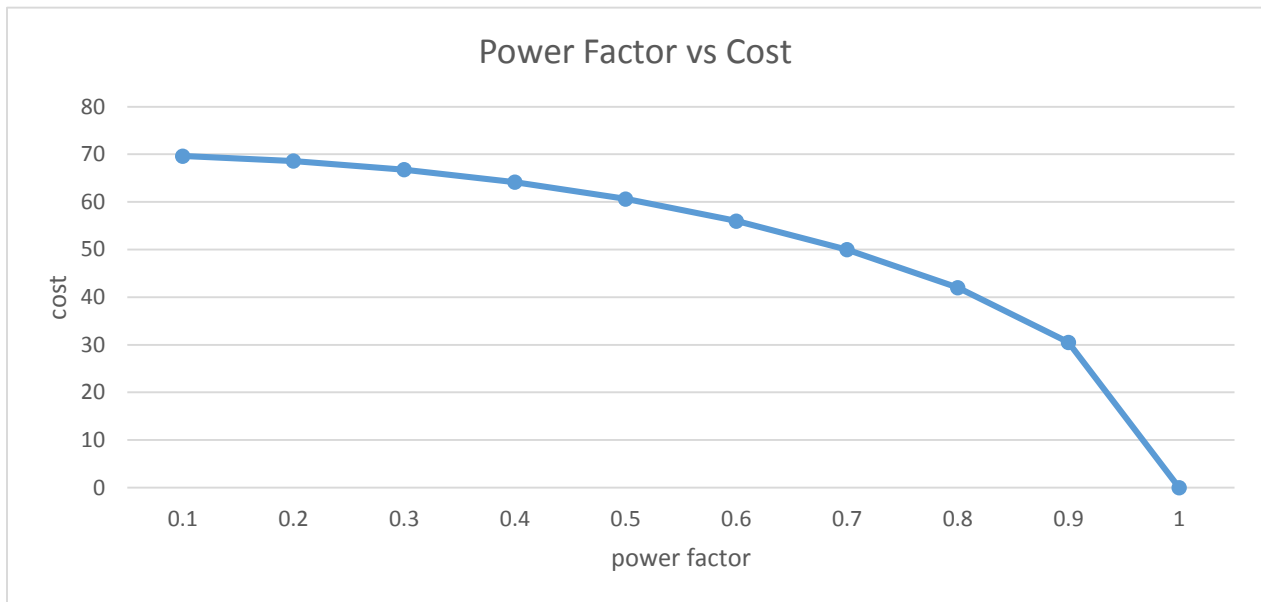

Fig 4.7: Power Factor vs Cost Curve

Case Study: It is evident from the upper graph and table that, as the less we are reducing the cost of capacitance the more power factor is getting improved. But the matter of fact that it is shifting towards unity which is not possible practically. This fact is showing here.

Sample 04: A 3- ϕ , 400 V motor develops 100 H.P. with frequency 50 Hz having the power factor being 0.75 lagging and efficiency 93%. A capacitors bank is connected in delta across the supply terminals thus power factor improve and varying from 0.85 to 0.95 lagging. Each of the capacitance units is built of 4 similar 100 V capacitors. Let's find out kVAR and capacitance.

Sample Calculation:

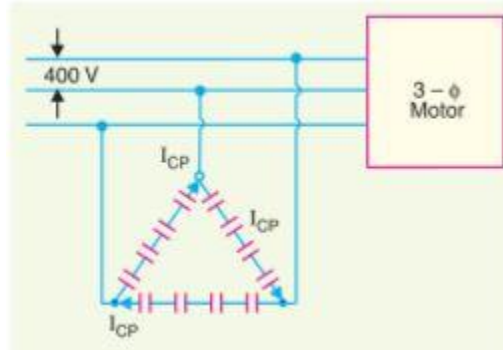

Fig: 4.8

Given that,

Motor power factor. $\cos\phi_1 = 0.75$

Assume, Capacitor bank has having power factor $\cos\phi_2 = 0.85$

Motor input power, $P = \frac{\text{output}}{\text{efficiency}} = \frac{74.6}{0.93} = 80kW$

$\phi_1 = \cos^{-1}(0.75) = 41.41^\circ$

$\tan\phi_1 = 0.8819$

$\phi_2 = \cos^{-1}(0.85) = 31.788^\circ$

$\tan\phi_2 = 0.6197$

Capacitor bank is being taken by leading kVAR = $P(\tan\phi_1 - \tan\phi_2) = 80(0.8819 - 0.6197)$
 $= 20.976 \text{ kVAR}$

Each of 3 sets is being taken by leading kVAR = $\frac{20.976}{3} = 6.992 \text{ kVAR} \dots \dots \dots (i)$

Delta connected condenser shown in fig 4.7. Let's find out the value of each 4 capacitor.

Capacitor phase current, $I_{CP} = \frac{V_{ph}}{X_C} = 2\pi f C V_{ph}$
 $= 2\pi \times 50 \times 400 \times C = 125663.71C \text{ Ampere}$

kVAR per phase = $\frac{V_{ph} \times I_{CP}}{1000} = \frac{400 \times 125663.71C}{1000} = 50265.484C \dots \dots \dots (ii)$

From equation (i) and (ii), we get,

$$50265.484C = 6.992$$

$$C = 139.1 \mu F$$

Since it is the combined capacitance of four equal capacitors joined in series,

$$\text{Capacitance of each capacitor} = 4 \times 139.1 = 556.4 \mu F$$

Power Factor	kVAR
0.1	-242.462
0.2	-107.41
0.3	-61.4415
0.4	-37.6842
0.5	-22.7312
0.6	-12.0701
0.7	-3.69757
0.8	3.527246
0.9	10.63103
1	23.58101

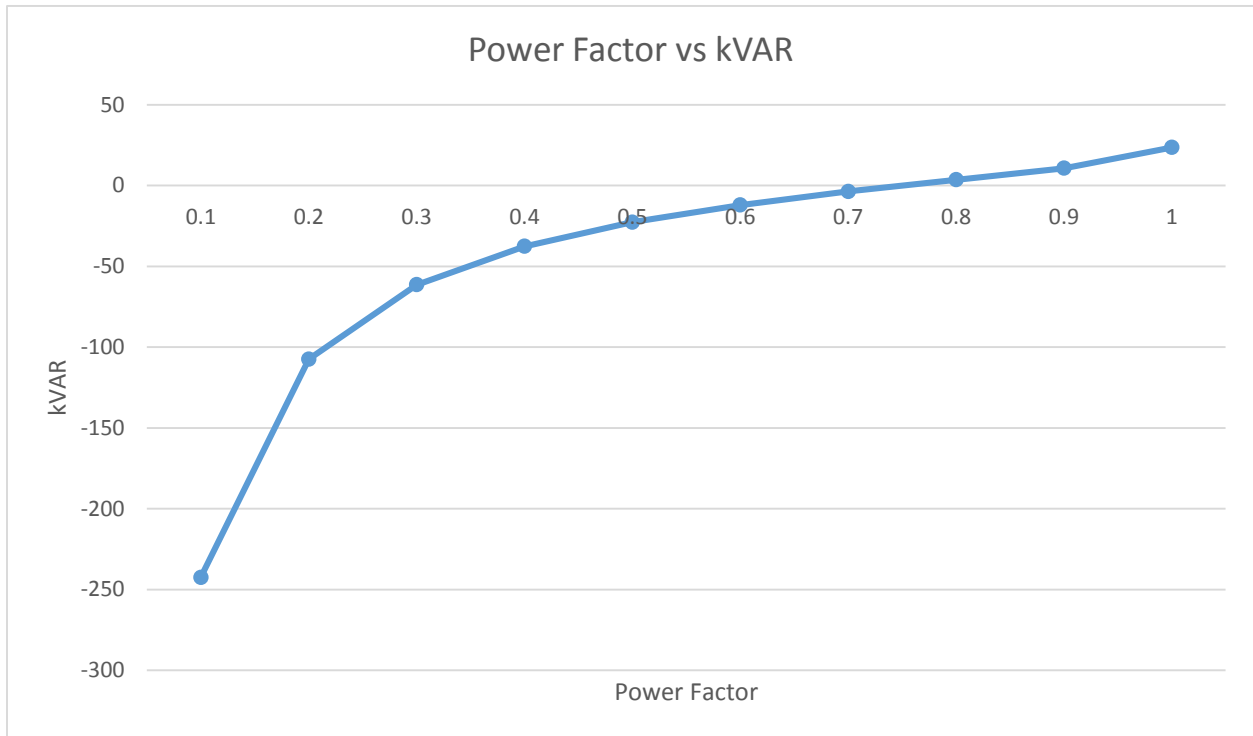

Fig 4.9: Power factor vs kVAR curve

Case Study: From the above graph and table, it easily can be understood that power factor increases the kVAR.

Power Factor	Combined Capacitance (F)
0.1	-19.2945
0.2	-8.54737
0.3	-4.88935
0.4	-2.99881
0.5	-1.80889
0.6	-0.96051
0.7	-0.29424
0.8	0.280689
0.9	0.845989
1	1.876513

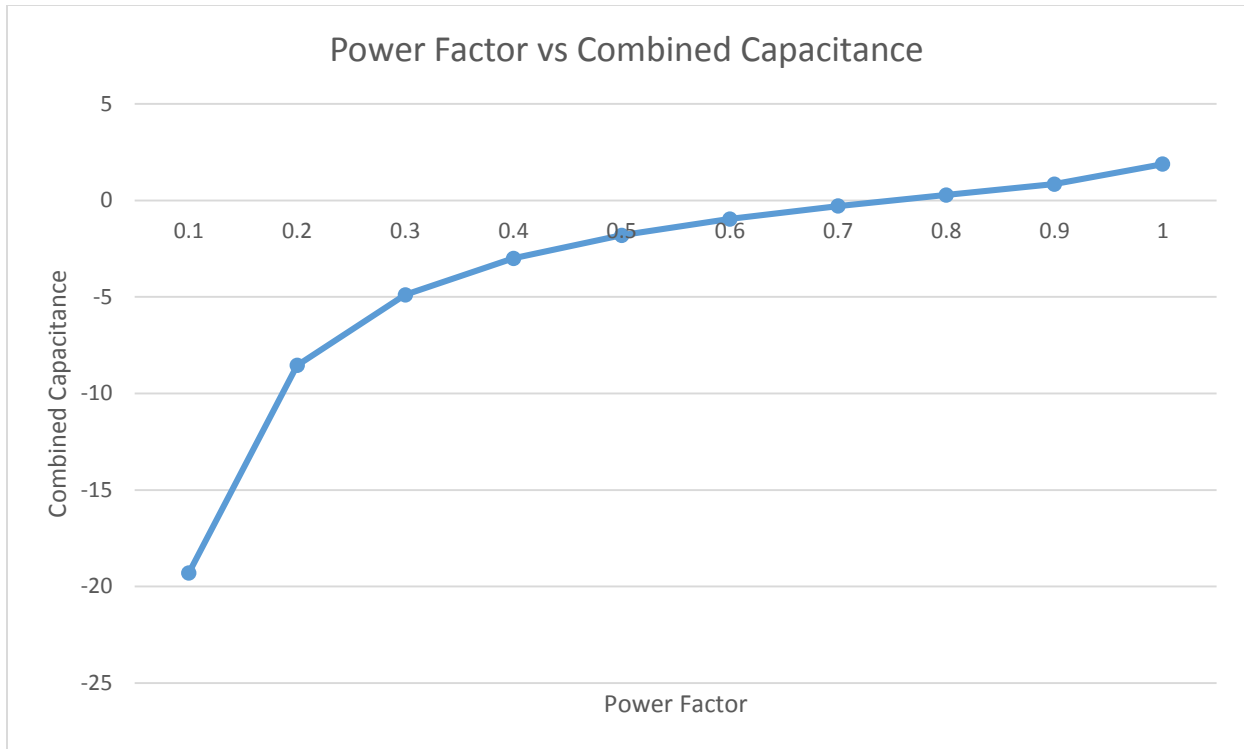

Fig 4.10: Power Factor vs Combined Capacitance Curve

Case Study: From the above graph and table, it easily can be understood that power factor increases the value of capacitance.

CHAPTER 5

POWER FACTOR IMPROVEMENT EQUIPMENT

5.1 INTRODUCTION

Power factor is the most important part for power system. Power factor directly depends on the power loss for power system. Power factor needs to be under control with some specific value. Power factor high means how much the value close to the value of 1. Power factor low means less than 1 .But ideally power factor value is one. Then the system is more reliable and effective and also low losses. So Power factor should be identified with equipment so that it can be minimized.

5.2 PRIMARY EQUIPMENT

Primary Equipment is basically which detects the power factor or measure the value of power factor. It is basically consists of sensor or sensing device.

5.3 More Power, Higher Efficiency, Smaller Size!

SynQor's line of Power Factor Correction modules are essential building blocks of any AC-DC power supply. These compact PFC modules are designed to provide engineers with solutions that offer best in class power density and efficiency. Both single phase input and 3-phase input PFC modules are available with either military-grade screenings, or industrial-grade screenings. Draw a nearly perfect sinusoidal current from a single phase, or 3-phase AC input. [9]



Fig 5.1: SynQor's Power Factor Correction Module

5.4 SECONDARY EQUIPMENT

Secondary equipment basically which actually perform to increase the power factor value. There are many device which performs power factor.

1. Compensation at LV
2. Fixed capacitors
3. Automatic capacitor banks

At low voltage, compensation is provided by:

1. Fixed-value capacitor
2. Equipment providing automatic regulation, or banks which allow continuous adjustment according to requirements, as loading of the installation changes

This arrangement employs one or more capacitor(s) to form a constant level of compensation. Control may be:

1. Manual: By circuit-breaker or load-break switch
2. Semi-automatic: By contactor
3. Direct connection to an appliance and switched with it

These capacitors are applied:

1. At the terminals of inductive devices (motors and transformers)
2. At bus bars supplying numerous small motors and inductive appliance for which individual compensation would be too costly
3. In cases where the level of load is reasonably constant



Fig 5.2: Secondary equipment

Automatic Capacitor Bank

This kind of equipment provides automatic control of compensation, maintaining the power factor within close limits around a selected level. Such equipment is applied at points in an installation where the active-power and/or reactive-power variations are relatively large, for example:

1. At the bus bars of a general power distribution board
2. At the terminals of a heavily-loaded feeder cable



Fig 5.3: Automatic Capacitor Bank

CHAPTER 6

CONCLUSION

6.1 INTRODUCTION

We have already seen that how much power factor is important for any system. Power factor is related to the total power efficiency. There are many importance of power factor. Economic Power factor is more important for any system. Power factor should be close to the value of 1.

An Electrical system which has power factor correction circuit could play certain roles. As example it gives reduced harmonics as well as distortion. As the circuit without PFC is prone to harmonics, distortion and current peaks. On the other hand it gives better efficiency at higher load currents unlike circuits with PFC, It also improves in power factor of the electrical system but there is a bit condition. As the efficiency increases only if with the increasing of load current.

6.2 FUTURE SCOPE

Power factor is the most important for any system. This is the most important affecting parameter for the system. The thesis presented here concern the development of the various techniques and their validation in different conditions for the enhancement of power quality using Active Filters. This research work can be extended to a multilevel inverter implemented for power conditioning. Three phase three wire system can be extended to three phase four wire system with different conditions like considering the zero sequence voltage 236 present in the system. FPGA based controller for Active Filter can be developed to reduce the hardware requirement. For sustainable growth in power system, recently Renewable and Non-Renewable Energy source are gaining lot of attention. Hence such energy sources feeding the nonlinear load can be investigated for further work in the field of power quality. Further enhancing the coordinated control of the proposed Distributed Active Filters incorporating the design of adaptive gains can also be implemented. Another attractive aspect that can be investigated is the finding the solutions of power quality issues by other emerging Evolutionary algorithm like.

REFERENCES

- [1] Mehta, V., & Mehta, R. (2017-2018). Principles of Power System. New Delhi-110 055, Ram Nagar, India: S. Chand & Company Ltd. Retrieved November 25, 2018
- [2] DAWARE, K. (2016, 03 1). BASICS OF ELECTRICAL POWER TRANSMISSION SYSTEM. RETRIEVED 2018, FROM [HTTPS://WWW.ELECTRICAL EASY.COM](https://www.electricaleasy.com): [HTTPS://WWW.ELECTRICAL EASY.COM/2016/03/BASICS-OF-ELECTRICAL-POWER-TRANSMISSION.HTML](https://www.electricaleasy.com/2016/03/basics-of-electrical-power-transmission.html)
- [3] BRANDSER, O. (2013, AUGUST 15). MOTOR EFFICIENCY, POWER FACTOR, AND LOAD. RETRIEVED NOVEMBER 25, 2018, FROM EC&M WEB: [HTTPS://WWW.ECMWEB.COM/MOTORS/MOTOR-EFFICIENCY-POWER-FACTOR-AND-LOAD?FBCLID=IWAR0ZzFxCa7hODv_hIThtA8kCEXCVv9OIQEbGwL2hTn8TccMyIR_y4Y4J-A](https://www.ecmweb.com/motors/motor-efficiency-power-factor-and-load?fbclid=IwAR0ZzFxCa7hODv_hIThtA8kCEXCVv9OIQEbGwL2hTn8TccMyIR_y4Y4J-A)
- [4] HYDROELECTRICITE. (2010, JANUARY 1). GENERATING STATION COMPONENTS AND THEIR OPERATION. RETRIEVED NOVEMBER 27, 2018, FROM HYDROELECTRICITE: [HTTP://WWW.HYDROELECTRICITE.CA/EN/THE-COMPONENTS-OF-A-FUNCTIONING-CENTRAL.PHP?HASFLASH=TRUE&](http://www.hydroelectricite.ca/en/the-components-of-a-functioning-central.php?hasFlash=true&)
- [5] NAILEN, R. L. (2017, JANUARY 1). DON'T COMPARE POWER FACTOR WITH EFFICIENCY. RETRIEVED NOVEMBER 25, 2018, FROM BRITHINEE ELECTRIC: [HTTP://WWW.BRITHINEE.COM/TECHNICAL-ARTICLES/DONT-COMPARE-POWER-FACTOR-WITH-EFFICIENCY/](http://www.brithinee.com/technical-articles/dont-compare-power-factor-with-efficiency/)
- [6] R. PAYNTER, B. B. (2011). TRANSMISSION LINES AND SUBSTATIONS (1ST ED., VOL. 25). UPPER SADDLE RIVER, NEW JERSEY: PEARSON.
- [7] TECHNOLOGY, E. (2018, NOVEMBER 3). DISADVANTAGES OF LOW POWER FACTOR. RETRIEVED NOVEMBER 3, 2018, FROM ELECTRICAL TECHNOLOGY: [HTTPS://WWW.ELECTRICALTECHNOLOGY.ORG/2013/08/DISADVANTAGES-OF-LOW-POWER-FACTOR.HTML](https://www.electricaltechnology.org/2013/08/disadvantages-of-low-power-factor.html)
- [8] [HTTPS://WWW.RESEARCHGATE.NET/PUBLICATION/308051408_POWER_FACTOR_CORRECTION](https://www.researchgate.net/publication/308051408_Power_Factor_Correction)
- [9] [HTTPS://WWW.SYNQOR.COM/POWER-FACTOR-CORRECTION-MODULES/PPC?GCLID=CJWKCAIA3VFGBRB9EiwAKFPD3DT1ABzACWRHwOSxZ7BTNYb0-5K-gNLOJTG9BqNQBZTYIFbCnCoJmBoC_PwQAvD_BwE](https://www.synqor.com/power-factor-correction-modules/ppc?gclid=CjwKCAIA3vfgBRB9EiwAKFPD3DT1ABzACWRHwOSxZ7BTNYb0-5K-gNLOJTG9BqNQBZTYIFbCnCoJmBoC_PwQAvD_BwE)
- [10] [HTTP://WWW.BPDB.GOV.BD](http://www.bpdb.gov.bd)
- [11] [HTTPS://ELECTRICALBABA.COM/POWER-FACTOR-IMPROVEMENT-CORRECTION-METHODS/](https://electricalbaba.com/power-factor-improvement-correction-methods/)