

RFID BASED DOOR LOCK WITH AUTOMATIC DOOR OPEN AND CLOSE

**A Project and Thesis submitted in partial fulfillment of the requirements
for the Award of Degree of
Bachelor of Science in Electrical and Electronic Engineering**

**Submitted By
Name: Md. Bahauddin.
ID: 153-33-3041**

**Name: Md. Abul Kalam Azad.
ID: 153-33-2941**

**Supervised by
DR.M. SHAMSUL ALAM
Professor, EEE & Dean
Faculty of Engineering
Department of Electrical and Electronics Engineering**



**DEPARTMENT OF ELECTRICAL AND ELECTRONIC ENGINEERING
FACULTY OF ENGINEERING
DAFFODIL INTERNATIONAL UNIVERSITY**

December 2018

Certification

This is to certify that this project and thesis entitled “**RFID Based Door Lock With Automatic Door Open And Close**” is done by the following students under my direct supervision and this work has been carried out by them in the laboratories of the Department of Electrical and Electronic Engineering under the Faculty of Engineering of Daffodil International University in partial fulfillment of the requirements for the degree of Bachelor of Science in Electrical and Electronic Engineering. The presentation of the work was held on December 2018.

Signature of the candidates

Name: Md. Bahauddin.
ID: 153-33-3041

Name: Md. Abul Kalam Azad.
ID: 153-33-2941

Countersigned

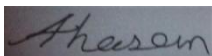

Dr.M. Shamsul Alam

Professor, EEE & Dean

Faculty of Engineering

Department of Electrical and Electronic Engineering

Daffodil International University.

The project entitled “ **RFID Based Door Lock With Automatic Door Open And Close**” submitted by **Md.Bahauddin**, ID No:153-33-3041 & **Md. Abul Kalam Azad**, ID No: 153-33-2941 Session: Fall 2015 has been accepted as satisfactory in partial fulfillment of the requirements for the degree of **Bachelor of Science in Electrical and Electronic Engineering** on December 2018.

Dedicated to

***Our Parents
And
Honorable Teachers***

CONTENTS

List of Figures	viii
List of Tables	Ix
List of Abbreviations	X
Acknowledgment	Xi
Abstract	Xii

Chapter 1: INTRODUCTION 1-5

1.1	Introduction	1
1.1.1	Problem Definition	1
1.1.2	Existing Solution	1
1.1.3	Proposed Solution	2
1.2	Problem Statement	3
1.3	Objectives	3
1.4	Scopes	4
1.5	Research Methodology	4
1.6	Project Outline	5

Chapter 2: BACKGROUND 6-7

2.1	Introduction	6
2.2	Summary of the chapter	7

Chapter 3: DESCRIPTION OF COMPONENTS 8-24

3.1	Introduction	8
3.2.1	Arduino Boards	8
3.2.2	Purpose of Arduino Boards	9
3.2.3	Features of Arduino Boards	9

3.2.4	The Arduino Uno	10
3.2.5	Arduino Uno Technical Specifications	11
3.2.6	Pin diagram of Arduino Uno R-3	12
3.2.7	Short description of the pins	13
3.2.8	RFID RC-522 Module	13
3.2.9	RFID RC-522 Module Pin Configuration	14
3.2.10	RFID RC-522 Module Features	15
3.2.11	Working Principle RFID RC-522 Module	15
3.2.12	Why use an RFID RC-522 Module r?	15
3.3.1	Buzzer	16
3.3.2	Applications for Buzzers	16
3.4.1	Led	17
3.4.2	Types of Led	17
3.5	Switch	17
3.6	Metal Oxide Field Effect Transistor	18
3.7	Transistor	19
3.8	Capacitor	20
3.9	PIC 16F877 Microcontroller	20
3.10	LCD Display	21
3.11	Resistor	22
3.12	Diode	22
3.13	Printed Circuit board	23
3.14	Summary of the chapter	24
 Chapter 4: ANALYSIS AND SIMULATION		25-30
4.1	Introduction	25
4.2	Block diagram of the project	26
4.3	Proposed circuit design	28
4.4	Hardware Design	29
4.5	Summary of the chapter	30
 Chapter 5: RESULTS AND DISCUSSIONS		31-32
5.1	Introduction	31
5.2	Discussion of Result	31

5.3	Summary of the chapter	32
Chapter 6:	CONCLUSIONS	33-34
6.1	Conclusion	33
6.2	Limitations of the Work	33
6.3	Future Scopes	34
	References	34
	Appendix	35-42

LIST OF FIGURES

Figure #	Figure Caption	Page #
3.2.4	The Arduino Uno R-3	10
3.2.6	Pin diagram of Arduino Uno R-3	12
3.2.8	RFID RC 522 module	14
3.3.1	Buzzer	16
3.4.1	Led	17
3.5	Switch	18
3.6	MOSFET	19
3.7	Transistor	19
3.8	Capacitor	20
3.9	LCD Display	21
3.11	Resistor	22
3.12	Diode	22
3.13	Printed Circuit Board	23
3.14	RFID Cared	24
4.2	Block Diagram of The Project	26
4.3	Proposed circuit Design	29
4.4	Hardware design	30

LIST OF TABLES

Table #	Table Caption	Page #
3.2.3	Features of Arduino Boards	09
3.2.5	Arduino Uno Technical Specifications	11
3.2.7	Short description of the pins	13
3.2.9	RFID RC 522 Module Pin Configuration	14-15

List of Abbreviations

RFID	Radio Frequency Identification
LED	Light Emitting Diode
UHF	Ultra-High Frequency
VCC	Voltage Common Collector
GND	Ground
IDE	Integrated Development Environment
RF	Radio Frequency
ID	Identification
PCB	Printed Circuit Board
RF	Radio Frequency
USB	Universal Serial Bus
PC	Personal Computer
SPI	Serial peripheral interface
DC	Direct Current
IC	Integrated Circuit

ACKNOWLEDGEMENT

First of all, we give thanks to Allah. Then we would like to take this opportunity to express our appreciation and gratitude to our project supervisor **Professor Dr. M. Shamsul Alam**, Dean of Faculty of Engineering for being dedicated in supporting, motivating and guiding us through this project. This project can't be done without his useful advice and helps. Also thank you very much for giving us opportunity to choose this project.

Apart from that, we would like to thank our entire friends for sharing knowledge; information and helping us in making this project a success. Also thanks for lending us some tools and equipment.

To our beloved family, we want to give them our deepest love and gratitude for being very supportive and also for their inspiration and encouragement during our studies in this University

ABSTRACT

In this paper, we introduce a RFID based door lock with automatic door open and close for Smart door lock system. Currently, our most people use a traditional door lock. Traditional door lock is manual and sometimes it cannot work properly, This traditional door lock open by simply use a replica key also it cannot store any data whose open the door for enter the home or whose come out this home. We were motivated to develop a RFID based door lock with automatic door open and close to overcome these limitations. First we design the RFID Based door lock with automatic door open into PROTEUS software then execute into hardware. The RFID Based door lock with automatic door open based on RFID RS-552 module, Arduino for Processing RFID tags data and PIC 16F877 Microcontroller for use to display who can access or who cannot access. Adding RFID RS-552 at specific to the resisted RFID tag in system that provided information about the authorized user to access into the room and activating the servomotor or when it detect un resisted RFID tag then system active buzzer and servomotor is off condition. Microcontroller (Arduino Uno R3) to receive the on RFID RS-552 signals and process them to the Arduino pins where buzzer and servomotor are connected. We seek in our project to provide a medium cost RFID based door lock with automatic door open and close and suitable for most securable, and also it is light in weight. Our device can detect signal RFID tag within the distance of about 10cm from the user.

CHAPTER 1

INTRODUCTION

1.1 Introduction

RFID based entryway bolt with programmed entryway open and close for use in home and office area. The framework joins RFID innovation to achieve the required undertaking. At the point when the RFID peruse introduced at the passage of home and office area, the framework examines the database for a match. In the event that both the card have a place with an enrolled client, get to is conceded; generally the framework turns on the alert. Along these lines, the suspicious people can be gotten.

1.1.1 Problem Definition

Everyone wants the best protection for their home, also with for vacations and come out for work away from home, security is more important than ever. Locks are designed to keep intruders away, but every once in a while, a key gets stuck or mechanism gets clogged. If the wrong key is inserted into a lock, it can get stuck. This can also happen with new keys. Stuck keys can be removed by spraying lubricant into the keyhole. If this doesn't work, contact a residential locksmith to help you so you don't damage the lock. As a lock gets older, it can become loose. In this case, your lock can be easily unlocked by using hairpins or other tools. It's extremely important to have a locksmith fix this issue right away so the security of your home isn't compromised.

1.1.2 Existing Solution

Customized unmistakable verification and access control system has ended up being essential to beat the security risks looked by many home and office. By presenting the structure at the path will simply empower the endorsed individuals to enter the home and office. The structure can moreover be presented at various demonstrates inside as far as possible their passage to delicate zones in the home

and office. In such a way, suspicious individuals can be gotten which will in all probability upgrade the security level in the home and office.

1.1.3 Proposed Solution

RFID card is utilized, which is inductively coupled to the peruser. At the point when the card is swiped against the peruser, the tweaked information from the card is send to the peruser. This information is bolstered to the microcontroller. The card utilized is the personality card for the specific individual and conveys his/her subtleties. At the point when this information matches with the information put away in the database of the microcontroller, the individual is given the expert to enter the anchored territory. Here this is shown by the drove being exchanged on. The microcontroller is customized to such an extent that when the information matches with the current information, the servomotor driver gets a high rationale contribution at one of its information stick. The relating yield stick goes low to give legitimate association with the servomotor. The status of power of the individual is likewise shown on the LCD show interfaced to the microcontroller. The system also needs Arduino Uno ,PIC microcontroller servomotor, buzzer, 9v batteries, led red, led blue, led green and push button. The proposed system consist of following sections:

- Input: RFID module RS552
- Control Unit: Arduino Uno and PIC 16F877 Microcontroller.
- Output: Buzzer, servomotor and Led Blue, Led Green and Led Red.

RFID RS-522 at specific to the resisted RFID tag in system that provided information about the authorized user to access into the room and activating the servomotor or when it detect un resisted RFID tag then system active buzzer and servomotor is off condition. Microcontroller (Arduino Uno R3) to receive the on RFID RS-522 signals and process them to the Arduino pins where buzzer and servomotor are connected also PIC 16F877 Microcontroller for use to display who can access or who cannot access. This device can detect signal RFID tag within the distance of about 10cm from the user.

1.2 Problem Statement

- I. Scanning Issues..
- II. Readers can not scan through in the metal.
- III. The fact that you cannot scan multiple objects in out of range.
- IV. RFID reader collision.
- V. RFID tag collision.
- VI. Problems of security and privacy of RFID.
- VII. Data corruption.

1.3 Objectives

➤ The main objective is to develop based door lock with automatic door open and close with RFID system. We need to build interface that will integrate with RFID system and will show the RFID tag card.

➤ **Cost**

Since the target user or customer is who want to secured his home or office and who normally has a medium income rate, the device should be cheap and affordable.

➤ **Ease of Use**

The device should be easy to use and manage for the user. Since the aim of the entire project is to simplify for use, it would be unreasonable to present to them a technologically-advanced tool. Also, there should be a user manual that interpret the functionalities of the device and provides training lessons on how to use it.

➤ **Power Consumption**

Whereas the device depends on the use of the user to supply power to the system, the overall power consumption of the device during its operation should be low.

1.4 Scopes

A variety of future scope are available that can be used of with the RFID door lock with automatic door open and close project such as usage of Global positioning System can help the smart security access control. GSM and IOT system can help to advantage for log content. Some more applications like highly secured locking system.

1.5 Research Methodology

On a fundamental dimension a RFID mark works as seeks after the scrutinizing unit makes an electro-alluring field which starts a current into the name's gathering mechanical assembly. The current is used to control the chip. In detached marks the current moreover charges a condenser which ensures ceaseless power for the chip. In unique names a battery replaces the condenser. The difference among dynamic and latent names is cleared up in merely seconds. At the point when sanctioned the tag gets headings from the scrutinizing unit and replies by sending its successive number or the requested information. With everything taken into account the tag does not have enough imperativeness to make its own one of a kind electro-appealing field, rather it uses back scattering to adjust (reflect/acclimatize) the field sent by the examining unit. Since most fluids hold electromagnetic fields and most metal mirror those fields the scrutinizing of names in closeness of those materials is obfuscated. In the midst of a scrutinizing cycle, the peruse needs to determinedly control the tag. The made field is called relentless wave, and in light of the way that the nature of the field decreases with the square of the division the peruses need to use a to some degree broad power. That field overpowers any response a tag could give, so along these lines names reply on side-channels which are found direct underneath or more the repeat of the steady wave.

1.6 Project Outline

This project report consists of six chapters which are Introduction, Background, Description of Components, Analysis and Simulation, Result and Discussions and Conclusions.

Chapter 1 is the introduction of the main idea and important of this project. In this chapter, we first explain the problem of visually impaired people then describe the existing solution of its. And After that we describe out proposed solution for visually impaired people. Also we discuss about the object of our project. And then describe the future scope and working methodology.

Chapter 2 is the background of the project. In this chapter reviews of some related works on RFID based door lock with automatic door open and close.

Chapter 3 is the Description of components where describe the all components that are used in the project.

Chapter 4 is the Analysis and simulation of the project that is illustrates the proposed solution for visually impaired people with the block diagram and flowchart. Also in this chapter focused on hardware and software design of the project.

Chapter 5 is the Result and Discussion where all the tested result is obtained. Also discuss about that result. In this chapter also discuss the cost analysis of the project.

Chapter 6 is the Conclusions. In this chapter we discuss about the conclusion, limitation of the project and future work of the project.

CHAPTER 2

LITERATURE REVIEWS

2.1 Introduction

This paper gives an examination on radio repeat unmistakable evidence (RFID) development. At first RFID names were delivered to over the long haul displace institutionalized distinguishing pieces of proof in supply chains. Their positive conditions are that they can be scrutinized remotely and without perceptible pathway, contain a larger number of information than institutionalized distinguishing pieces of proof, and are logically overwhelming. The paper delineates the present advancement, including the repeat ranges used and standards. With the extending inescapability of RFID names, nevertheless, insurance transformed into a stress. The paper charts possible strikes that can ignore one's insurance and it in like manner depicts counter measures. The RFID advancement did not stop at thing level marking. The paper moreover presents stream ask about that bases on finding and following checked article that move. Since the uses for RFID names are so sweeping, there is a colossal eagerness for cutting down the costs for making them. Eminently, printing names may transform into a sensible choice as opposed to standard creation. The paper reviews the present progression.

2.2 Summary of the chapter

This paper presented a diagram on RFID development. RFID development has a noteworthy potential to end up inescapable within the near future. Today it is currently successfully used in store organize the officials to pursue beds of things. Following grants better coordination and control in the age cycle. Directly the business is pushing towards thing level naming to construct the control altogether further. Regardless, that moreover makes concerns, most fundamental assurance concern, yet also other security related issues. The paper showed possible circumstances how security can be risked by RFID names yet likewise a couple of answers for guarantee against it. Since RFID advancement ends up being progressively typical, strikes against the structure itself start to appear. This paper recorded the most outstanding, start from standard sniffing and tuning in over renouncing of organization to new RFID contaminations. The paper in like manner showed that there is an entire other world to RFID than basically store organize the administrators. The paper covers instruments that allow finding or following a conceivably moving article. To wrap things up the paper additionally reviews

inquire about for new creation techniques for labels. At present printing labels with natural materials is by all accounts a promising methodology. By printing labels, the cost-concentrated gathering of the two fundamental segments, receiving wire and chip, can be killed. It likewise adds higher adaptability to generation. Radio Frequency Identification - AM The paper finishes up by taking a gander at some social ramifications that RFID causes. Despite the fact that not in fact pertinent, it gives a decent outside viewpoint.

CHAPTER 3

DESCRIPTION OF COMPONENTS

3.1 Introduction

This part depicts the hypothetical data of this undertaking associates with the explicit application and the air interface. Every single practical segment of this task are portrayed in extraordinary express. This archive can help us rapidly see all gadget interface determinations, electrical and mechanical subtleties. With the assistance of this archive and other application notes, client control, we can utilize Arduino, RFID Module, Buzzer, drove and servomotor to Design the RFID based entryway bolt with programmed entryway open and close.

3.2.1 Arduino Boards

Arduino board is an open-source sort out, used to make equipment adventures. It contains both a microcontroller and a bit of the item or Incorporated Improvement Condition (IDE) that continues running on your (PC), used to create and exchange PC code to the physical board the entresol of an Arduino has ended up being to a great degree celebrated, with organizers or understudies just start with contraptions, and for an amazing reason. Not in any manner like most earlier programmable circuit sheets, the Arduino does not require an alternate bit of gear in order to program another code onto the board you can just use a USB connect. As well, the Arduino IDE uses a key version of C++, making it simpler to take in the program. At last, Arduino board offers an ordinary casing issue that breaks out the components of the microcontroller into a much available package.

3.2.2 Purpose of Arduino Boards

These sheets have been utilized for making different ventures. The product on this board is simple, to use for students, yet adaptable sufficient for inventive clients. It keeps running on windows, Mac and Linux. Instructors and understudies in the schools use it to manufacture, minimal effort logical devices to affirm the standards of material science and science. There are different other microcontroller stages realistic for physical processing. The Net media's BX-24, MIT's Handy board, Parallax Basic Brand, Phi get and different others present related usefulness. Arduino board likewise makes less difficult the working methodology of microcontroller, however it gives about preferred standpoint on over different frameworks for fledglings, educators, and understudies. Sensible, Cross-

stage Modest, impeccable programming environment, Open source, extensible equipment, and programming.

3.2.3 Features of Arduino Boards

Table 3.2.3 Features of Arduino Boards

Arduino Board	Processor	Memory	Digital I/O	Analogue I/O
Arduino Uno	6Mhz ATmega328	2KB SRAM, 32KB flash	14	6 input, 0 output
Arduino Due	84MHz AT91SAM3X8E	96KB SRAM, 512KB flash	54	12 input, 2 output
Arduino Mega	16MHz ATmega2560	8KB SRAM, 256KB flash	54	16 input, 0 output
Arduino Leonardo	16MHz ATmega32u4	2.5KB SRAM, 32KB flash	20	12 input, 0 output

3.2.4 The Arduino Uno

The Uno is a microcontroller board base on the ATmega328P. It has a 16 MHz quartz significant stone, a USB connector, a power jack, an ICSP header and a reset switch. It holds everything needed to help the microcontroller; just interface it to a PC with a USB association or power it with an air conditioner to-DC connector or battery to begin. The Uno board and casing 1.0 of Arduino Programming (IDE) were the reference varieties of Arduino, eventually made discharges. The Uno board is the first in a development of USB Arduino sheets, and the reference appear for the Arduino deal with; for an aggregate, outline of current, past or outdated sheets see the Arduino inbox of sheets.

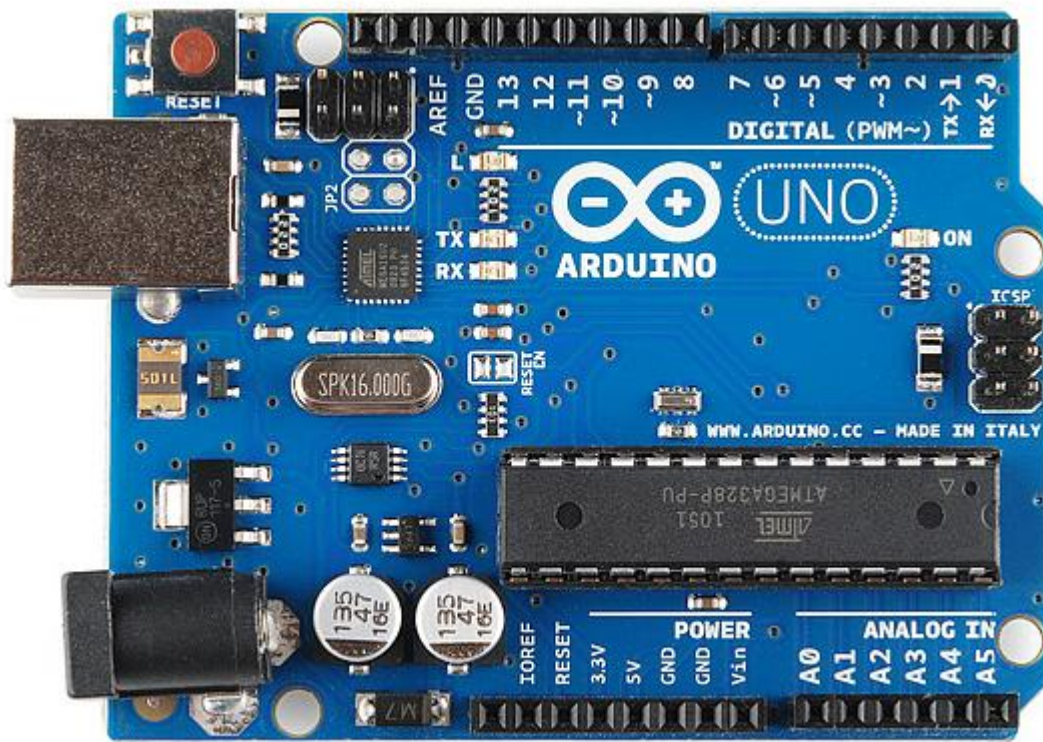

Fig. 3.2.4 Arduino Uno R-3

The Uno is a microcontroller board based on the ATmega328P. It has a 16 MHz quartz crystal, a USB connector, a power jack, an ICSP header and a reset switch. It holds everything needed to help the microcontroller; just interface it to a PC with a USB association or power it with an air conditioner to-DC connector or battery to begin. The Uno board and casing 1.0 of Arduino Programming (IDE) were the reference varieties of Arduino, eventually made discharges. The Uno board is the first in a development of USB Arduino sheets, and the reference appear for the Arduino deal with; for an aggregate, outline of current, past or outdated sheets see the Arduino inbox of sheets.

3.2.5 Arduino Uno Technical Specifications

Table 3.2.5 Arduino Uno Technical Specifications

Microcontroller	ATmega328P – 8bit AVR family microcontroller
Operating Voltage	5V
Recommended Input Voltage	7-12V
Input Voltage Limits	6-20V
Analog Input Pins	6 (A0 – A5)
Digital I/O Pins	14 (Out of which 6 provide PWM output)
DC Current on I/O Pins	40 mA
DC Current on 3.3V Pin	50 mA
Flash Memory	32 KB (0.5 KB is used for Bootloader)
SRAM	2 KB
EEPROM	1 KB
Frequency (Clock Speed)	16 MHz

3.2.6 Pin diagram of Arduino UNO R-3

Atmega168 Pin Mapping

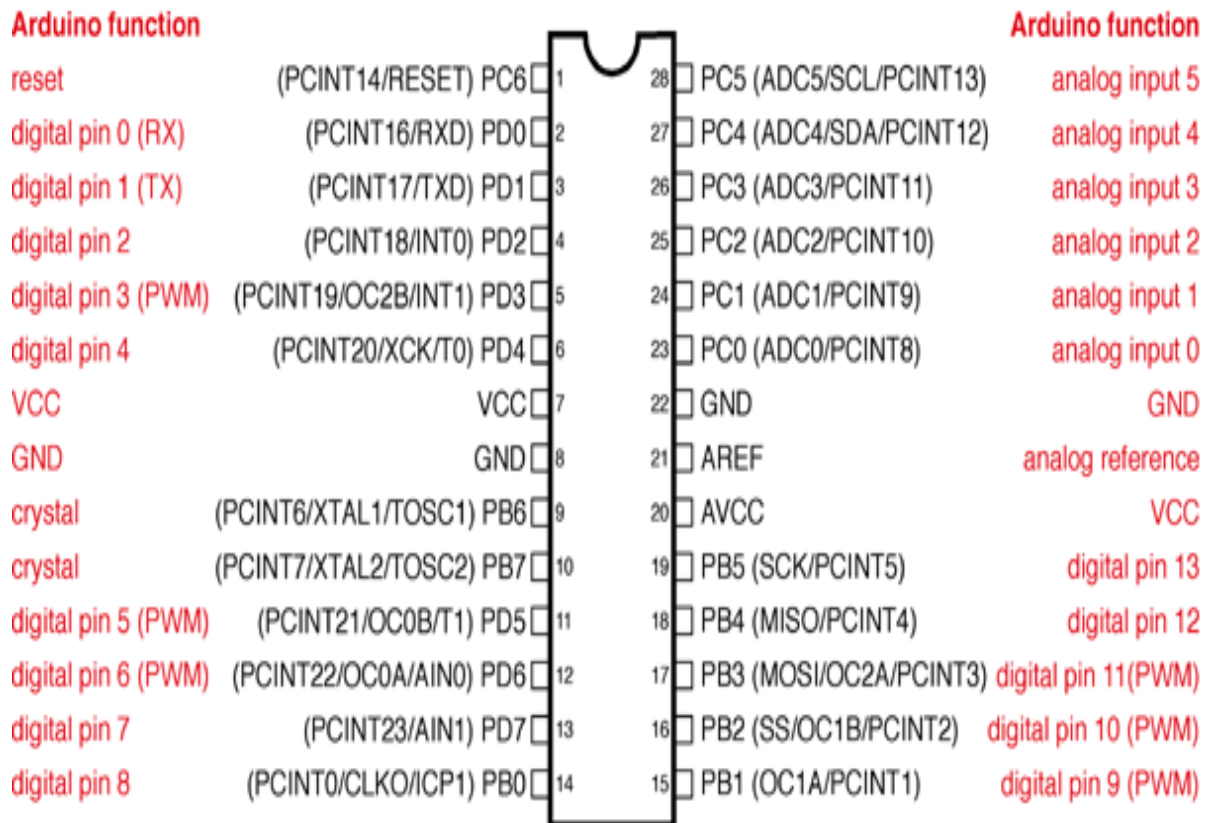

Digital Pins 11, 12 & 13 are used by the ICSP header for MOSI, MISO, SCK connections (Atmega168 pins 17, 18 & 19). Avoid low-impedance loads on these pins when using the ICSP header.

Fig: 3.2 Pin diagram of Arduino UNO R-3

3.2.7 Short description of the pins:

Table: 3.3 Short description of the pins

Pin Category	Pin Name	Details
--------------	----------	---------

Power	Vin, 3.3V, 5V, GND	Vin: Info voltage to Arduino when utilizing an outer power source. 5V: Controlled power supply used to control microcontroller and different segments on the board. 3.3V: 3.3V supply produced by on-board voltage controller. Greatest current draw is 50 Mama. GND: ground pins..
Reset	Reset	Resets the microcontroller.
Analog Pins	A0 – A5	Used to provide analog input in the range of 0-5V
Pins of Input /Output	Digital Pins 0 – 13	Can be used as output or input pins.
Serial	0(Rx), 1(TX)	Used to receive and transmit TTL serial data.
External Interrupts	2, 3	To trigger an interrupt.
PWM	3, 5, 6, 9, 11	Provides 8-bit PWM output.
SPI	10 (SS), 11 (MOSI), 12 (MISO) and 13 (SCK)	Used for SPI communication.
Inbuilt LED	13	To turn on the inbuilt LED.
TWI	A4 (SDA), A5 (SCA)	Used for TWI communication.
AREF	AREF	To provide notice, voltage for input voltage.

3.2.8 RFID RC 522 Module

RC522 - RFID Peruser/Author 13.56MHz with Cards Unit joins a 13.56MHz RF peruser cum writer module that uses a RC522 IC and two S50 RFID cards. The MF RC522 is an uncommonly organized transmission module for contact-less correspondence at 13.56 MHz. RC522 supports ISO 14443A/MIFARE mode. The module uses SPI to talk with microcontrollers. The open-gear organize starting at now has a lot of exercises mishandling the RC522 – RFID Correspondence, using Arduino.

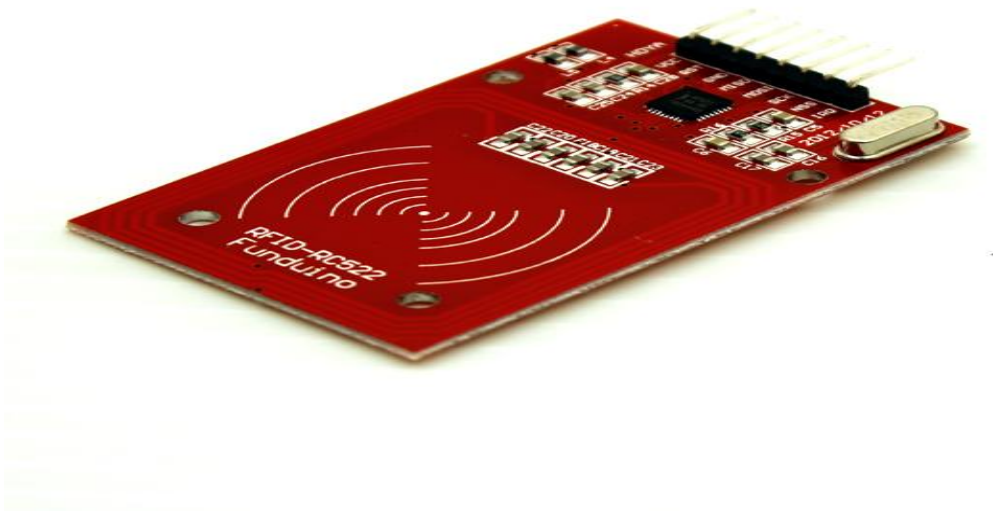

Fig: 3..2.8 RFID RC 522 Module

3.2.9 RFID RC 522 Module Pin Configuration

Table: 3.4 Ultrasonic sensor pin configuration

Pin Number	Pin Name	Description
1	SDA	Serial Data The Vcc pin powers the sensor, typically with +3.3V
2	SCK	Serial Clock.
3	MOSI	Master Out slave in.
4	MISO	Master in slave out.
5	IRQ	Interrupt request
6	GND	Ground

7	RST	Reset
8	+3.3V	The Vcc pin powers the sensor, typically with +3.3V

3.2.10 RFID RC-522 Module Features

- Module Name:MF522-ED
- Working current : 13 - 26mA / DC 3.3V
- Standby current : 10 - 13mA / DC 3.3V
- Sleep current : <80uA
- Peak current : <30mA
- Working frequency : 13.56MHz
- Card reading distance : 0~60mm (Mifare1 card)
- Protocol : SPI
- Data communication speed : 10Mbit/s Max.
- Card types supported: Mifare1 S50, Mifare1 S70, Mifare UltraLight, Mifare Pro, Mifare Desfire
- Dimension : 40mm × 60mm
- Working temperature : -20—80 degree
- Storage temperature : -40—85 degree
- Humidity : relevant humidity 5%—95%

3.2.11 Working Principal of RFID RC-522 Module

RFID RC-522Module is the high coordinated RFID card peruser which takes a shot at non-contact 13.56 mhz correspondence, is planned by NXP as a low power utilization, minimal effort and reduced size read and compose chip, is the best decision in the improvement of shrewd meters and compact hand-held gadgets.

3.2.12 Why use an RFID RC-522 Module?

A radio-recurrence recognizable proof (RFID) based access-control framework enables just approved individuals to enter a specific region of a foundation. Approved individuals are furnished with one of a kind labels, utilizing which they can get to that zone. This RFID put together security framework is based with respect to miniaturized scale controller AT89C52 and contains a RFID module, a LCD module for showing the status and a servomotor for opening the entryway.

3.3.1 Buzzer

A chime is a mechanical, electromechanical, appealing, electromagnetic, electro-acoustic or piezoelectric sound pennant ling instrument, A piezo electric ringer can be driven by a floundering electronic circuit or other sound standard source. A tick, banner or ring can show that as.



catch has been squeezed.

Figure 3.3.1 Buzzer

3.3.2 Applications for Buzzers

Typical uses of buzzers include:

- Alarm devices
- Timers
- Confirmation of user input
- Electronic metronomes
- Annunciator panels
- Game shows
- Sporting events
- Household machinery

3.4.1 Led

Driven, in full light-creating diode, in electronic a semiconductor device that releases infrared or evident light when blamed for an electric stream. Clear LEDs are used in various electronic contraptions as marker lights, in automobiles as back window and brake lights, and on sheets and signs as.

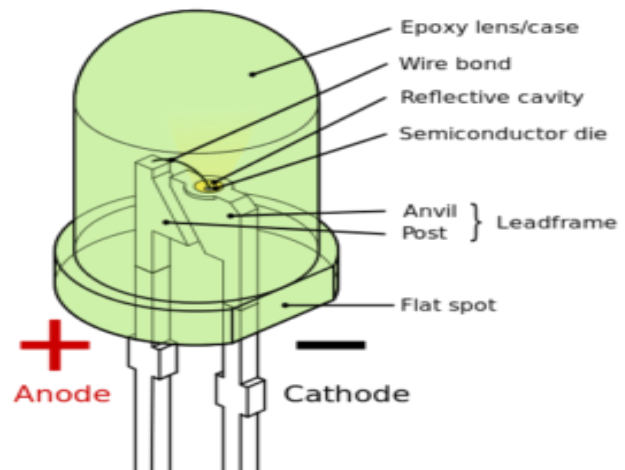

alphanumeric shows or even full-shading blurbs.

Figure 3.4.1 Led

3.4.2 Types of LED

- Through-hole LEDs
- SMD LEDs (Surface Mount Light Emitting Diodes)
- RGB LED (Red – Blue – Green Led)
- High – Power LEDs
- Bi-color LEDs

3.5 Switch

A switch is somewhat of a physical equipment portion that directs the banner stream. Having a switch or flip switch empowers a relationship with be opened or close. At whatever point opened, the switch agrees a banner or ability to travel through the affiliation. At whatever point close, the switch stops the stream and breaks the circuit affiliation.



Figure 3.5 Switch

3.6 MOSFET

A metal oxide field effect transistor a field effect transistor (FET with a secured entryway) where the voltage chooses the conductivity of the contraction. It is used for trading or strengthening signs. The ability to change conductivity with the proportion of associated voltage can be used for upgrading or trading electronic signs. MOSFETs are by and by considerably more commonplace than BJTs (bipolar convergence transistors) in cutting edge and straightforward circuits.



Figure 3.6 MOSFET

3.7 Transistor

A transistor is a semiconductor gadget used to intensify and switch electronic signs and electrical power. A voltage or current connected to one sets of the transistor's terminals changes the current through another combine of terminals. A transistor is made out of semiconductor material with something like three terminals for association with an outer circuit.

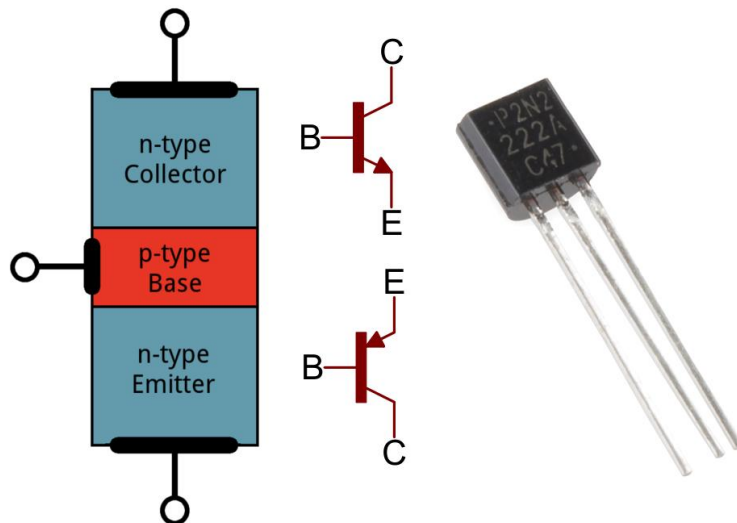

Figure 3.7 Transistor

3.8 Capacitor

A capacitor is a segregated segment planned to store essentialness in its electric field. A capacitor stores electrical essentialness. This pool of electrons is open for electronic parts to use. Capacitance is evaluated in Farads. The little capacitors commonly used in equipment are consistently assessed in microfarads and nanofarads. Capacitors supply a pool of electrons for provoke use. Capacitors can smooth out a banner – wipe out the swells or spikes in DC voltage.



Figure 3.8 Capacitor

3.9 PIC 16F877 Microcontroller

The 16F877A is a gifted microcontroller that can do different assignments since it has a satisfactorily wide programming memory (monstrous to the degree sensor and control undertakings) 8k words and 368 Bytes of RAM. The principal drawback that you could level at it is that it doesn't have an inner clock source like most by a wide margin of the other logically current PIC's. At any rate utilizing an outside check if all else fails results in quicker endeavor since you can pick a 20MHz profitable stone instead of the ordinary interior 8MHz oscillator.

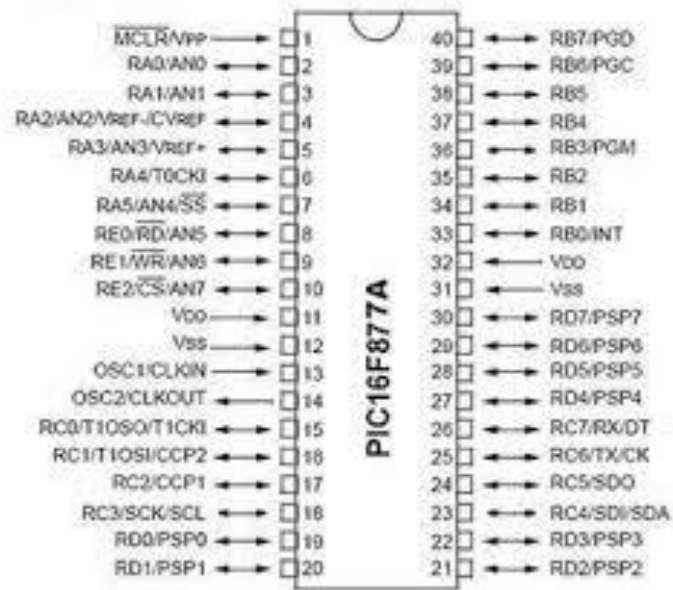

Figure 3.9 PIC16F877 Microcontroller

3.10 LCD Display

LCD (Liquid Crystal Display) screen is an electronic grandstand module and find a wide extent of employments. A 16x2 LCD indicates is amazingly central module and is normally used in various devices and circuits. These modules are supported in excess of seven parts and other multi section LED. The reasons being: LCDs are proficient; easily programmable; have no constraintment of appearing and even custom creature (not at all like in seven segments), enthusiasm in this manner on. A 16x2 LCD suggests it can indicate 16 characters for each line and there are 2 such lines. In this LCD each character is appeared 5x7 pixel grid. This LCD has two registers, explicitly, Command and Data.



Figure 3.10 LCD display

3.11. Resistor

A resistor blocks the stream of power through a circuit. Resistors have a set esteem. Since voltage, current and opposition are connected through Ohm's law, resistors are a decent method to control voltage and current in your circuit.

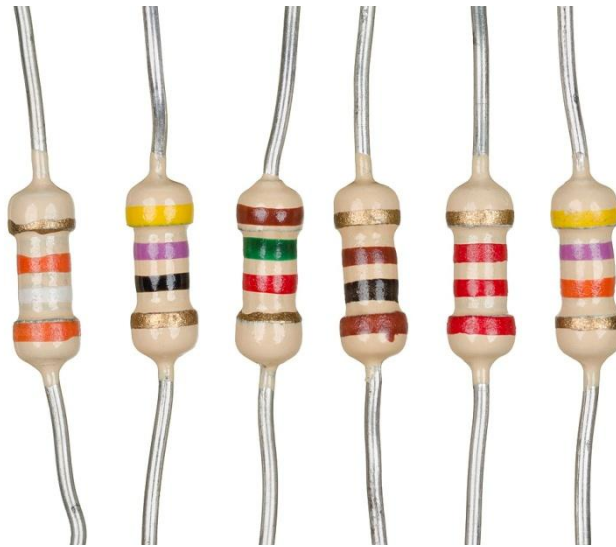

Figure 3.11 Resistor

3.12 Diode

A diode is a restricted valve (or door) for power. It is a part with a hilter kilter exchange trademark. A diode has low (in a perfect world zero) obstruction in one heading, and high (preferably unending) opposition in the other bearing.



Figure 3.11 Diode

3.13 Printed circuit board

Parts are connected to a printed circuit board. The 'front' side of the board will have printed part data, for example, resistor and opposition, diode type and extremity, and so forth. Gaps go completely through the board from one side to the next. Through gap binding is expected to interface parts to the board. The 'back' side of the board will have lines demonstrating associations between parts. The lines on the back are like wires. Thicker lines signify progressively current (electrons) traveling through. Parts interface the lines.

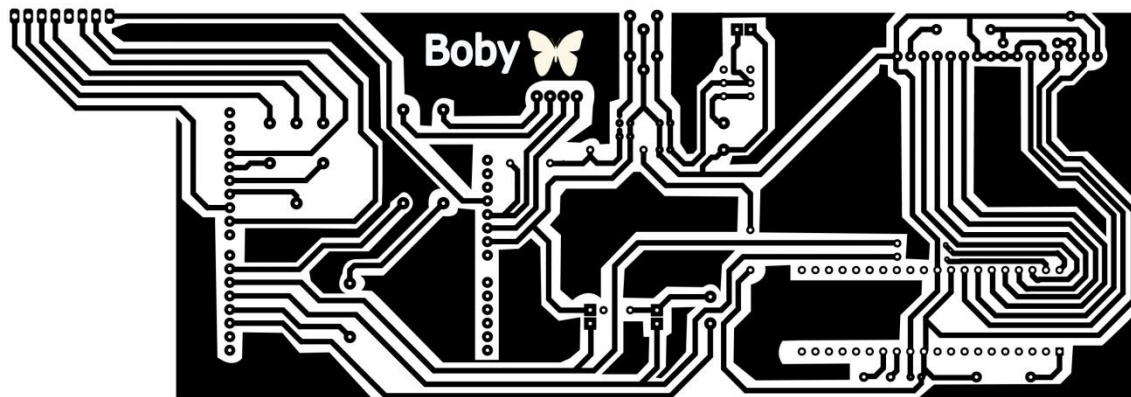

Figure 3.13 Printed Circuit Board

3.14 RFID Card

RFID card is a EEPROM memory chip, which has the capability to store data in the memory. RFID has an antenna that generates electric energy from electromagnetic force which comes from the RFID reader antenna. Then the RFID card chip is activated and sends data which is stored in the RFID card.

Types of RFID Card

- I. **Low Frequency (LF) RFID** ----- 30 KHz to 300 KHz
- II. **High-Frequency (HF) RFID**----- 3 to 30 MHz
- III. **Ultra-high frequency (UHF) RFID**-- 300 MHz to 3 GHz



Figure 3.12 RFID Card

3.13 Summary of the chapter

In this chapter, we introduction each equipment that we have used in the project. Also we discuss the feature, working principal, types and example of the equipment.

CHAPTER 4

ANALYSIS AN SIMULATION

4.1 Introduction

The RFID Door Lock will have 3 information sources and 2 yields. Power is an essential data and will supply the RFID Door Lock with the imperative voltage and streams to work. It will be worked with 5V supply and will be drawn through an AC connector. The second data is the RFID Sensor Input. This is the place the RFID name information will enter the system. As for the banner paying little heed to whether to keep the passage catapulted or opens the door. These contemplations are graphically addressed in BLOCK DIAGRAM Input Description Power Supplies voltage to the RFID Door Lock and powers it for all limits. RFID Sensor Input Scans for RFID names and opens or remains catapulted depending upon settings and RFID tag. The hidden Level 1 weakening, the RFID Door Lock can be isolated into 5 fundamental parts. The RFID Input (the RFID tag) goes into a RFID sensor that will by then be put into the MCU (or Microcontroller). In perspective of the programming and the settings. Power is a basic data and will passage Lock with the major voltage and streams to work. It will be worked with 5V supply and will be drawn through an AC connector. The second data is the RFID Sensor Input. This is the place the RFID mark information will enter the system. Concerning the yields, the Unlock/Lock is the place the RFID Door Lock sends the banner paying little mind to whether to keep the passage catapulted or open the portal.

4.2 Block diagram of the project

The Basic need of security can be achieved by structuring different entryway bolts, for example, mechanical locks or electrical locks. These sort of entryway locks are planned with at least one keys, however to bolt a vast territory different locks are required. For the most part, conventional locks are overpowering and that are not strong as they can hurt basically by using a couple mechanical assemblies. Electronic jolt are better over mechanical locks, to decide the security issues that are related with the mechanical locks. Starting late every device uses electronic advancement. For example, ID of cutting edge device using token, gateway jolt system using automated development, customized door opening and closing, modified portal jolt structures, etc. These kind of systems is used for controlling the improvement of a gateway without using a key..

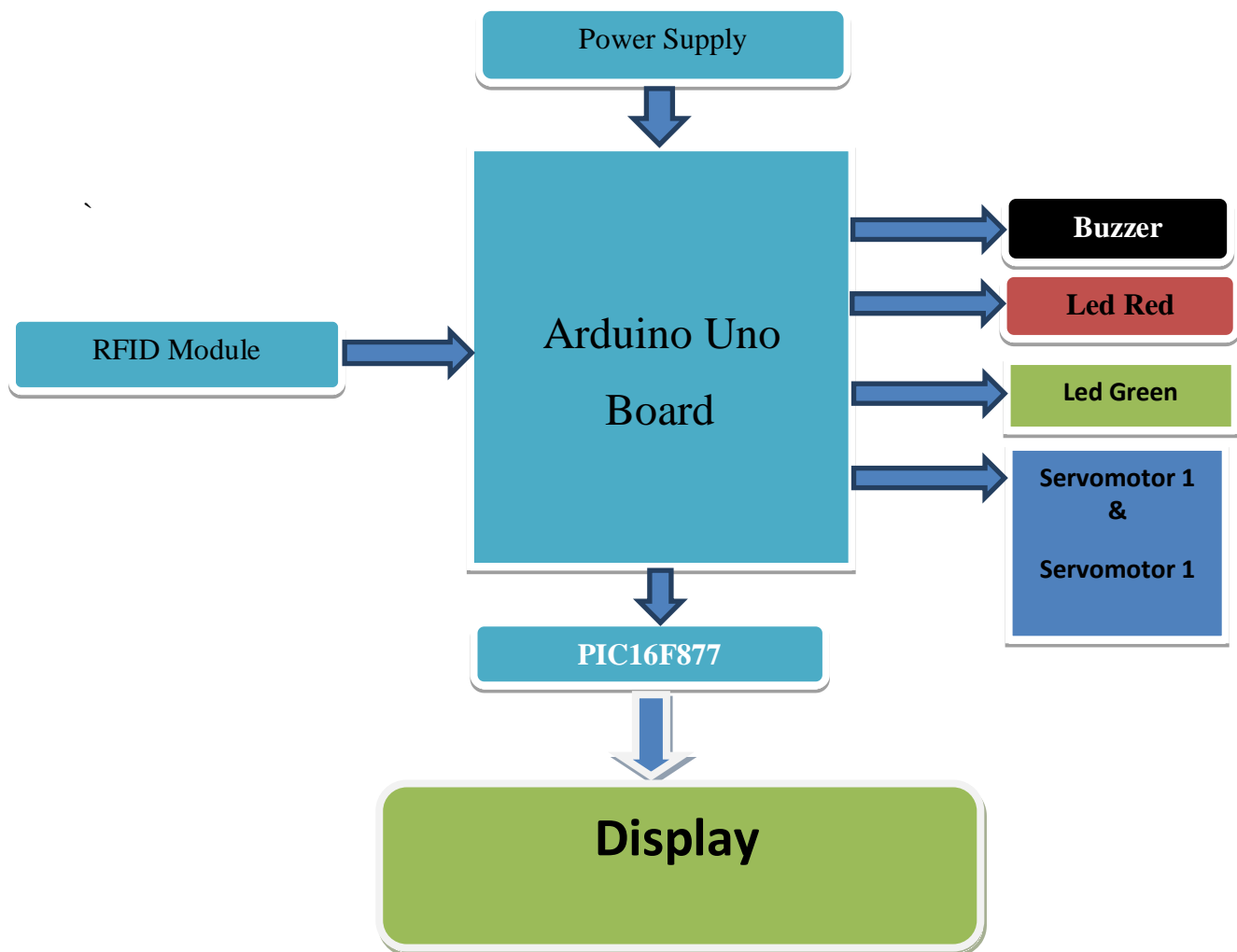

Fig: Block Diagram of RFID based door lock with automatic door open and close.

The RFID peruser is a remote gadget used to exchange information for perceiving and following labels associated with items. The tag incorporates electronically put away data. Some sort of labels is controlled by electromagnetic enlistment from attractive fields framed close to the peruses. RFID peruse incorporates a RF module and it goes about as a both TX and RX of radio recurrence signals. The transmitter of this module contains an oscillator to make the bearer recurrence. A modulator to barge in information directions upon this bearer s/L and a speaker to build the flag enough to wake the tag. The collector of this module incorporates a demodulator to separate the returned data and furthermore holds an enhancer to help the flag for preparing. A chip is utilized to shape the control unit, which utilizes an OS and memory of this module channel and stores the data. The need of intensity supply for RFID perusers changes starting with one item then onto the next. There are numerous RFID perusers are accessible in the market with 5v, 9v and 12v. In any case, here a 12v RFID peruser is utilized for an interfacing. You may affirm the RFID peruser and RFID labels are recurrence good. The programmed entryway bolt framework circuit outline utilizing an Arduino is appeared as follows. This circuit is for the most part utilized for an interfacing of RFID peruses with an Arduino. This undertaking can be improved by associating a LCD show to show the yields. The circuit of this task utilizes three separate parts, to be specific a peruses, a controller and entryway bolt. Where a peruser peruses the RFID labels, a controller is utilized to acknowledge the information from the RFID pursuer and control the o/p of the entryway bolt and RGB LED. When the entryway bolt is put on an entryway and tried with a battery to check the establishment. By and large we require a basic circuit on the entryway bolt, that implies the programmed entryway stops bolted when there is no stream of current.

4.3 Proposed circuit design

➤ The structure model of the entire undertaking was finished after the equipment implemeWe have constructed the circuit to reenact venture utilizing Proteus v7.8 which is appeared in Fig. 4.3. Proteus is a reproduction and plan programming apparatus created by Labcenter Electronics for Electrical and Electronics circuit design ntation.

➤ **About Proteus**

➤ It has ISIS which is utilized for circuit structuring with reenactment and ARES which is utilized for PCB planning [16].

➤ • ISIS is the product used to draw schematics and reenact the circuits in genuine time. The reproduction grants human access amid run time, accordingly giving constant recreation.

➤ • ARES is utilized for PCB structuring. It has the element of watching yield in 3D perspective of the structured PCB alongside parts.

➤ **Features**

• ISIS has wide extent of parts in its library. It has sources, hail generators, estimation and examination contraptions like oscilloscope, voltmeter, ammeter, etc. tests for consistent checking of the parameters of the circuit, switches, appears, loads like engines and lights, discrete parts like resistors, capacitors, inductors, transformers, modernized and straightforward Integrated circuits, semi-conductor switches, exchanges, microcontrollers, processors, sensors thus forth. ARES offers PCB arranging up to 14 inside layers, with surface mount and through whole packages. It is embedded with the impressions of various class of parts like ICs, transistors, headers, connectors and other discrete portions. It gives Auto guiding and manual directing options in contrast to the PCB Designer. The schematic pulled in the ISIS can be sincerely traded ARES.

• Proteus is the simple and most fundamental programming with most recent innovation for circuit execution and recreation. Counting essential parts with comparing data from its library it tends to be recreated after set up the circuit. Microcontroller needs to incorporate the hex document for the execution of entire task. Proteus joins circuit recreation to encourage co-reproduction of finish microcontroller based designs. We are utilizing this product since this is particularly easy to use to structure and recreate any circuits than utilizing other software's. The gear's utilized for structure and execution of the accompanying circuit are Arduino Uno R3, ultrasonic Sensor, ringer, drove red, drove blue, drove Green, pot-hg and virtual terminal.

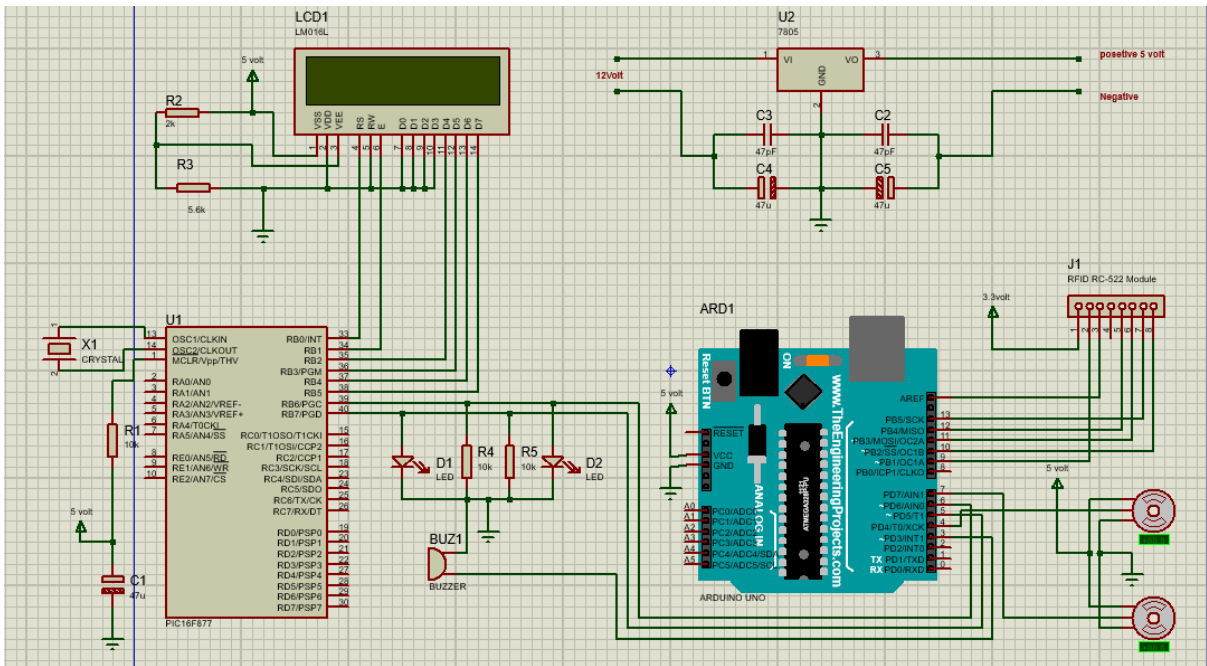

Fig 4.3: Schematic Diagram of the circuit

4.4 Hardware Design

The structure model of the entire task was finished after the equipment usage.

Figure 4.4 shows the hardware implementation of the whole project.



Fig 4.4: RFID based door lock with automatic door open and close

4.5 Summary of the chapter

In this chapter illustrates the RFID based door lock with automatic door open and close with block diagram and flowchart. Also focused on software design and hardware design of the project.

CHAPTER 5

RESULT AND DISCUSSION

5.1 Introduction

The RFID Door Lock is a bolt that is easy to introduce and enables the client to effectively bolt and open entryways. It will contain a RFID peruser/essayist and an attractive entryway bolt for straightforward use. All the client will require is a RFID tag to have the capacity to open and bolt the entryway. A LED will be utilized to tell the client when the entryway is in certainty bolted. The segments incorporated into the module are little and minimal. Furthermore, the entryway bolt is basic and simple to introduce. It doesn't require the shopper to dismantle the entryway or door jamb as the entryway bolt are simply connections. This is additionally leaves the purchaser with the choice of utilizing their unique bolt and key on the off chance that they so pick. With everything taken into account, this RFID entryway bolt ought to be a basic and financially savvy move up to the normal customer's security and accommodation.

5.2 Result

The RFID peruser is set outwardly of the entryway and it is isolates from the controller privately so nobody can stay away from the security by tearing open the RFID peruser and attempting to hamper peruser. The controller of this task gets sequential data from the RFID peruser and controls the Door bolt and the LED. Along these lines, at last we can infer that, when the individual swipes with right RFID tag, at that point the entrance control framework will be will be allowed. Similarly, when the individual swipes with an unapproved RFID card, at that point the information won't be stacked and access will be denied. Consequently, this is about RFID peruser, an Arduino board, interfacing of RFID peruser with Arduino, RFID based entryway bolt with programmed entryway open and close

System with Arduino, circuit graph of Automatic Door Lock System and working. We trust that you have a superior comprehension of this idea. Besides, any questions with respect to this idea or secret phrase based entryway locking framework, When we see modern entryway the board system(s), the sticker price hit quickly alongside the utility obviously. In nations like India, such programmed frameworks are not modest by any measuring stick. Along these lines, we chose to test a basic and modest model to check whether such a powerful framework could be produced utilizing our preferred device, Arduino Uno. That is the manner by which we began to build up this venture and are exceptionally content with the manner in which it at long last looks. Obviously, there are bunches of future augmentations that we are intending to force upon this venture,

5.3 Summary of the chapter

at long last we can infer that, when the individual swipes with right RFID tag, at that point the entrance control framework will be will be allowed. Similarly, when the individual swipes with an unapproved RFID card, at that point the information won't be stacked and access will be denied

CHAPTER 6

CONCLUSIONS

6.1 Conclusion

In this paper, a model of programmed get to control framework for use in a domain is introduced. The framework utilizes radio recurrence ID (RFID) with Arduino innovation to separate among approved and unapproved clients. The RFID peruses RFID tag issued to the client and matches it with put away UID on the Microcontroller. On an effective match, the microcontroller gifts get to or deny get to if no match was found. A programmed access control framework utilizing Arduino and RFID has been prototyped and worked as wanted. The framework can be introduced at the passage of an anchored situation to keep an unapproved singular access to nature.

6.2 Limitation of the Study

While there are numerous advantages to including a RFID entryway secure framework your home, there are some significant disadvantages to consider too. While RFID entryway bolt frameworks are commonly protected and intended to alarm police or different specialists if inaccurate codes are entered too often, it is in any case conceivable that an interloper might have the capacity to access your home through this framework by speculating or hacking the code. Similarly as you can overlook your keys and be bolted out of your home, you can likewise overlook the pass code to get to your RFID passage framework and be bolted out. While it is more secure to utilize a totally irregular code and evade evident decisions like birth dates or basic, monotonous numbers, this can represent an issue in the event that you have a troublesome time recollecting things. So clients need to set a code that simple to recall yet difficult to break. One last drawback of RFID entryway locks is that electrically-fueled frameworks may not work legitimately on account of a power disappointment. This can leave your entryway totally bolted all through the disappointment, or it might result in the entryway not bolting legitimately and staying open. Luckily, most frameworks have battery reinforcement

frameworks as a safeguard. There is a low power alert framework in RFID entryway locks. The clients need to change the batteries in time. At that point you'll never meet this issue.

6.3 Future Scopes of the Work

A variety of future scope are available that can be used of with the RFID door lock with automatic door open and close project such as usage of Global positioning System can help the smart security access control. GSM and IOT system can help to advantage for log content. Some more applications like highly secured locking system .

REFERENCES

- [1] <https://howtomechatronics.com/tutorials/arduino/rfid-works-make-arduino-based-rfid-door-lock/>
- [2] <https://circuitdigest.com/microcontroller-projects/arduino-rfid-door-lock-code>
- [3] <https://www.hackster.io/sarful/rfid-based-door-lock-system-using-arduino-05ccc2>
- [4] <https://www.hackster.io/muhammad-aqib/rfid-and-keypad-door-lock-and-alert-system-using>
- [5] <https://create.arduino.cc/projecthub/sarful/rfid-door-access-control-with-counter-f5cf45>
- [6] <http://www.circuitstoday.com/simple-rfid-based-door-lock-using-arduino>
- [7] <https://create.arduino.cc/projecthub/projects/tags/lock>
- [8] <https://create.arduino.cc/projecthub/vikkey321/coolest-door-lock-ever-ecb2e1>
- [9] <https://www.instructables.com/id/RFID-door-lock-with-Arduino/>
- [10] <https://www.instructables.com/id/RFID-door-lock-with-Arduino/>
- [11] Tarun Agarwal, (2015), "RFID based Automatic Door Lock System with Arduino", Retrieved 19 October 2017, from <https://www.elprocus.com/automatic-door-lock-system-using-rfid-and-arduino/>.

Appendix

Programming Code uses in the ATMEL 328 Microcontroller:

```
#include <SPI.h>

#include <MFRC522.h>

#include <Servo.h>

#define SS_PIN 10

#define RST_PIN 9

#define LED_G 5 //define green LED pin

#define LED_R 4 //define red LED

#define BUZZER 2 //buzzer pin

MFRC522 mfrc522(SS_PIN, RST_PIN); // Create MFRC522 instance.

Servo myServo; //define servo name

Servo myServo1;

void setup()

{

  Serial.begin(9600); // Initiate a serial communication

  SPI.begin(); // Initiate SPI bus

  mfrc522.PCD_Init(); // Initiate MFRC522

  myServo.attach(3); //servo pin
```

```

myServo.write(0); //servo start position

myServo1.attach(6); //servo pin

myServo1.write(90);

pinMode(LED_G, OUTPUT);

pinMode(LED_R, OUTPUT);

pinMode(BUZZER, OUTPUT);

noTone(BUZZER);

Serial.println("Put your card to the reader...");

Serial.println();

}

void loop()

{

// Look for new cards

if ( ! mfrc522.PICC_IsNewCardPresent() )

{

return;

}

// Select one of the cards

if ( ! mfrc522.PICC_ReadCardSerial() )

{

return;

}

//Show UID on serial monitor

Serial.print("UID tag :");

```



```

String content= "";

byte letter;

for (byte i = 0; i < mfrc522.uid.size; i++)

{

    Serial.print(mfrc522.uid.uidByte[i] < 0x10 ? " 0" : " ");

    Serial.print(mfrc522.uid.uidByte[i], HEX);

    content.concat(String(mfrc522.uid.uidByte[i] < 0x10 ? " 0" : " "));

    content.concat(String(mfrc522.uid.uidByte[i], HEX));

}

Serial.println();

Serial.print("Message : ");

content.toUpperCase();

if (content.substring(1) == "93 5F 87 2E") //change here the UID of the card/cards that you want to give access

{

    Serial.println("Authorized access");

    Serial.println();

    delay(500);

    digitalWrite(LED_G, HIGH);

    delay(900);

    digitalWrite(LED_G, LOW);

    tone(BUZZER, 900);

    delay(300);

    noTone(BUZZER);

    myServo.write(180);

    delay(500);

```

```
myServo1.write(180);

delay(8000);

myServo1.write(90);

delay(500);

myServo.write(0);

digitalWrite(LED_G, LOW);

}

else {

    Serial.println(" Access denied");

    digitalWrite(LED_R, HIGH);

    tone(BUZZER, 300);

    delay(1000);

    digitalWrite(LED_R, LOW);

    noTone(BUZZER);

}

}
```

Programming Code uses in the PIC16F877 Microcontroller:

```
/**This programe for LCD**/  
  
// Lcd module connections  
  
sbit LCD_RS at RB0_bit;  
  
sbit LCD_EN at RB1_bit;  
  
sbit LCD_D4 at RB2_bit;  
  
sbit LCD_D5 at RB3_bit;  
  
sbit LCD_D6 at RB4_bit;  
  
sbit LCD_D7 at RB5_bit;  
  
  
sbit LCD_RS_Direction at TRISB0_bit;  
  
sbit LCD_EN_Direction at TRISB1_bit;  
  
sbit LCD_D4_Direction at TRISB2_bit;  
  
sbit LCD_D5_Direction at TRISB3_bit;  
  
sbit LCD_D6_Direction at TRISB4_bit;  
  
sbit LCD_D7_Direction at TRISB5_bit;  
  
// End Lcd module connections  
  
  
//-----//  
  
char txt2[] = "Door close 8sec";  
  
char txt3[] = "Door close 7sec";
```

```
char txt4[] = "Door close 6sec";  
char txt5[] = "Door close 5sec";  
char txt6[] = "Door close 4sec";  
char txt7[] = "Door close 3sec";  
char txt8[] = "Door close 2sec";  
char txt9[] = "Door close 1sec";
```

```
//-----//
```

```
void main()
```

```
{
```

```
    // SWITCH OUTPUT
```

```
    TRISB.B7 = 1;        // switch input
```

```
    TRISB.B6 = 1;
```

```
    Lcd_Init();
```

```
    Lcd_Cmd(_LCD_CURSOR_OFF);
```

```
    Lcd_Cmd(_LCD_CLEAR);
```

```
do{
```

```

//----- //

if (PORTB.B7 == 1)          // condition match

{

    Lcd_Cmd(_LCD_CLEAR);

    Lcd_Out(1, 2, "Access Granted");

    Lcd_out(2, 3, "--Wellcome--");

    delay_ms(3000);

    Lcd_Cmd(_LCD_CLEAR);

    Lcd_out(1, 1, txt5);

    delay_ms(1000);

    Lcd_out(1, 1, txt6);

    delay_ms(1000);

    Lcd_out(1, 1, txt7);

    delay_ms(1000);

    Lcd_out(1, 1, txt8);

    delay_ms(1000);

    Lcd_out(1, 1, txt9);

    delay_ms(1000);

    Lcd_Cmd(_LCD_CLEAR);

```

```
    }  
    if (PORTB.B6 == 1)  
    {  
        Lcd_Cmd(_LCD_CLEAR);  
        Lcd_Out(1, 1, "--Access Denies--");  
        Lcd_out(2, 3, "Unauthorized!");  
        delay_ms(3000);  
    }  
  
    else { Lcd_Cmd(_LCD_CLEAR);  
        Lcd_Out(1, 2, "Swip your card");  
        lcd_out(2, 7, "please");  
        delay_ms(300);  
    }  
  
} while(1);
```

