

INTERFERENCE MITIGATION OF Wi-Fi NETWORKS

BY

MD. MAHIR HASAN CHOWDHURY
151-19-1676

MD. ISMAIL
151-19-1702

MD. HAMIMUL HASAN MARUF
151-19-1706

This Report Presented in Partial Fulfillment of the Requirements for the Degree of
Bachelor of Science in Electronics and Telecommunication Engineering.

Supervised By
Md. Taslim Arefin
Associate professor & Head
Department of ICE
Daffodil International University



DAFFODIL INTERNATIONAL UNIVERSITY
DHAKA, BANGLADESH
DECEMBER 2018

APPROVAL

This Project titled “ **Interference Mitigation Of Different Wireless Network Environment**”, submitted by **Md. Mahir Hasan Chowdhury, Md. Ismail, and Md. Hamimul Hasan Maruf** to the Department of Information and Communication Engineering, Daffodil International University, has been accepted as satisfactory for the partial fulfillment of the requirements for the degree of B.Sc. in Electronics and Telecommunication Engineering and approved as to its style and contents. The presentation was held on December 2018.

BOARD OF EXAMINERS

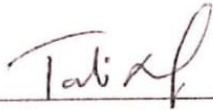

(Md. Taslim Arefin)
Associate Professor & Head
Department of ICE
Faculty of Engineering
Daffodil International University

Chairman

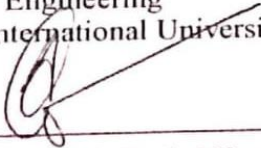

(Prof. Dr. A.K.M. Fazlul Haque)
Associate Dean
Faculty of Engineering
Daffodil International University

Internal Examiner

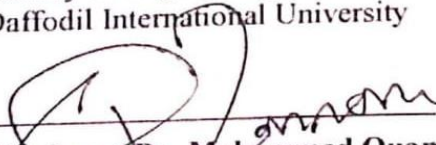

(Professor Dr. Mohammad Quamruzzaman)
Professor
Department of ICE
Faculty of Engineering
Daffodil International University

Internal Examiner

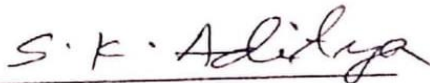

(Dr. Subrata Kumar Aditya)
Professor
Department EEE
University of Dhaka

External Examiner

DECLARATION

We hereby declare that this project has been done by us under the supervision of **Md. Taslim Arefin, Associate Professor & Head, Department of ICE** Daffodil International University. We also declare that neither this project nor any part of this project has been submitted elsewhere for the award of any degree or diploma.

Supervised by:

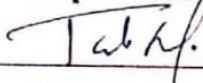

Md. Taslim Arefin
Associate Professor & Head
Department of ICE
Daffodil International University

Submitted by:



Md. Mahir Hasan Chowdhury
ID: 151-19-1676
Department of ICE
Daffodil International University

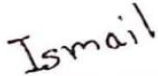

Md. Ismail
ID: 151-19-1702
Department of ICE
Daffodil International University



Md. Hamimul Hasan Maruf
ID: 151-19-1706
Department of ICE
Daffodil International University

ACKNOWLEDGEMENT

First, we express our heartiest thanks and gratefulness to almighty Allah for His divine blessing makes us possible to complete this project successfully.

This work would not have been possible without the support and guideline of **Md. Taslim Arefin, Associate Professor & Head**, Department of ICE Daffodil International University, Dhaka. Deep Knowledge & keen interest of our supervisor in the field of wireless network influenced us to carry out this project. His endless patience, scholarly guidance, continual encouragement, constant and energetic supervision, constructive criticism, valuable advice, reading many inferior drafts and correcting them at all stage have made it possible to complete this project.

We would like to express our heartiest gratitude to Prof. Dr. A.K.M. Fazlul Haque, Mrs. Shahina Haque, and Head, Department of ICE, for his kind help to finish our project and also to other faculty member and the staff of ICE department of Daffodil International University.

We would like to thank our entire course mate at Daffodil International University, who took part in this discuss while completing the course work.

Finally, we must acknowledge with due respect the constant support and patients of our parents.

ABSTRACT

Wireless network interference mitigation plays a significant role and that seriously considered as a major task when designing a wireless network topology. To design a wireless network effectively various interference mitigation techniques are applied. The use of wireless technology is increasing day by day, for that interference in wireless technology also increase. So the interference in the wireless technology needs to identify and take the necessary steps to mitigate it. In this project different interference mitigation techniques for a wireless network has been designed and presented, using Wi-Fi analyzer, Wi-Fi SNR, Network manager software. Also, this project has been conducted the interference causes and the wireless devices placement. The different wireless devices (Netist, TP-LINK, Cambium) have been used for analyzing the interference and mitigate it.

TABLE OF CONTENTS

CONTENTS	PAGES
Board of examiners	ii
Declaration	iii
Acknowledgements	iv
Abstract	v
CHAPTERS :	
CHAPTER 1: Introduction	(10-12)
1.1 Introduction	10
1.2 Problem description	11
1.3 Related work	12
1.4 Disposition	12
Chapter 2. General Concept	(13-19)
2.1 Wireless technology and wireless interference	13
2.1.1 Technology	13
2.1.2 Types of Wireless Networks	14
2.1.3 Wi-Fi (802.11) phy/mac standards	15
2.1.4 Some common causes of wireless interference	16
2.1.5 Sources of interference	17
2.1.6 Interference From Household Appliances	19
Chapter 3: INTERFERENCE & MITIGATION CONCEPTS	(20-28)
3.1 Basic concept	20
3.2 Effects of Interference Seen by Clients	20
3.3 Channel and Interference	20
3.4 Adaptive Frequency Hopping	21
3.5 Interference Mitigation Techniques	21
3.5.1 Mitigating interference with smarter antennas	22
3.6 Wanted stronger signals and less interference	23

3.6.1	Reduce effects of interference from other wireless devices	24
3.6.2	Stop Bluetooth Interference From Messing With our Other Devices	24
3.6.3	How to Stop Frequency Interference	25
3.7	Proper Attempts to reduce Wi-Fi and Bluetooth interference	26
3.8	GPS Synchronization	26
3.9	Avoid wireless interference using Beamforming	26
3.10	Synchronization in Wireless Communications	27
Chapter 4 : Wireless devices placement		(29-36)
4.1	Background	29
4.2	Existing Interference Resources	29
4.3	Interference Modeling: Open Loop	30
4.4	Non-Perseverance	31
4.5	Adjustable Duty Series	31
4.6	Valuation Test	32
4.7	Beat Wi-Fi Interference with “NetSpot”	34
4.7.1	Netspot and Its Functions	34
4.7.2	How Netspot Works	35
4.7.3	Discover Mode	35
4.7.4	Wi-Fi Surveys	36
Chapter 5: Simulation and Result		(37-48)
5.1	Interference Occurs	37
5.1.2	Avoid Interference	40
5.2	Overlapping	43
5.2.1	Channel Change to mitigate The interference	44
5.3	5GHz Frequency Band Use To Avoid Interference	46
5.4	Result	48
Chapter 6: Performance Analysis		(49-55)
Chapter: 7		(56)
Conclusion		
References		(57-59)

LIST OF FIGURES

Figure 3.1 :	SNR signal Ratio Respect With Time	22
Figure 3.2 :	Ap with integrated antenna array with SINR	23
Figure 4.1:	Simple access technique of IEEE 802.11 b	32
Figure 4.2 :	Device deployment for evaluation test	33
Figure 4.3 :	Wi-Fi analyzing with Netspot in discovery mode	35
Figure 4.4 :	Wi-Fi analyzing with Netspot in survey mode	36
Figure5.1 :	Ground Floor Wireless Topology	37
Figure 5.2(a) :	Channel graph 1	38
Figure 5.2(b) :	Time Graph 1	38
Figure 5.2(c) :	Time Graph 2	38
Figure 5.3 :	Speed Test (when interference Occurs)	38
Figure 5.4 :	Wi-Fi SNR (Signal To Noise Ratio) Graph	39
Figure 5.5 :	Ground Floor Wireless Topology (Near To AP)	40
Figure 5.6(a) :	Channel Graph	41
Figure 5.6(b) :	Time Graph (1)	41
Figure 5.6(c) :	Time Graph (2)	41
Figure 5.7 :	Speed test (Avoiding Interference)	41
Figure 5.8 :	Wi-Fi SNR (Signal To Noise Ratio)	42
Figure 5.9 :	Channel Graph	43
Figure 5.10 :	Speed Test (Overlapping)	43
Figure 5.11 :	Wi-Fi SNR (Signal To Ratio)	44
Figure 5.12 :	Speed Test (Channel-Changing)	45
Figure 5.13 :	Wi-Fi SNR (Signal To Noise Ratio)	45
Figure 5.14 :	Speed test Of 5GHz Frequency Band	46
Figure 5.15 :	5Ghz Frequency Band Wi-Fi SNR (Signal to Noise ratio)	47
Figure 6.1:	Decreased SNR for avoid interference	49
Figure 6.2:	Increased download speed for avoid interference	50
Figure 6.3:	Increased update speed for avoid interference	50
Figure 6.4:	Increased download & update speed for avoid interference	51
Figure 6.5:	Decreased SNR for SNR for Channel Changing	51

Figure 6.6:	Increased download speed for avoid interference	52
Figure 6.7:	Increased update speed for Channel Changing	52
Figure 6.8 :	Increased download & update speed for Channel Changing	53
Figure 6.9:	Decreased SNR for SNR for Frequency Changing	53
Figure 6.10:	Increased download speed for Frequency Changing	54
Figure 6.11:	Increased update speed for Frequency Changing	54
Figure 6.12:	Increased download & update speed for Frequency Changing	55

LIST OF TABLES

Table 2.1 :	Types of wireless network	14
Table 2.2 :	History of 802.11 PHY/MAC standards	16
Table 5.1 :	Values Of Before Interference Mitigation	39
Table 5.2 :	Values Of Avoiding Interference	42
Table 5.3 :	Values Of When Overlapping Occurs	44
Table 5.4 :	Values Of Channel Changing	46
Table 5.5 :	Values Of 5GHz Frequency Band	47

Chapter 1: INTRODUCTION

1.1 Introduction

The improvement of wireless networks has modulated consistently ways of life into such a situation, to the point that we can't expect of ways of life aside from contraptions like computers, cell phone phones etc. The wireless systems that interconnect these units are including additional and more hubs into it every single minute. These devices speak with each other the utilization of numerous well-known necessities created through IEEE and such extraordinary gatherings. Contrasting this with the 2.4 GHz modern, logical, and medicinal (ISM) band furthermore, 5 GHz unlicensed national data foundation (UNII) groups where Wi-Fi is utilized, the 60 GHz band has in excess of multiple times more extensive range. While exploring different avenues regarding various settings of the WLAN gadgets, we have seen that the DSSS units are lovely resistant against near to transmissions in connecting channels, while OFDM stations end up being non-practical even in adjoining channel quality dimensions a mess lower than those routinely existing in our arrangements. In spite of the fact that the nearby/substitute channel security and dismissal parameters esteems are plainly characterized in the 802.11 gauges, it is unimaginable to expect to find any WLAN item which would announce the genuine estimations of these parameters in an assortment of activity modes. Additionally, it is currently not possible to discover any WLAN item which would proclaim estimations of ALL parameters portrayed in the 802.11 gauges. The most mainstream among these correspondence principles are IEEE 802.11 or Wi-Fi and the Bluetooth. Relatively 75% of the gadgets in the portable processing world are outfitted with both of these or both. These advances utilize the radio recurrence for correspondence.

The Bluetooth works in 2.4GHz ISM band, Unfortunately, IEEE 802.11 also works in the indistinguishable 2.4GHz ISM band that reason's monstrous impedance. There are distinctive varieties of IEEE 802.11 like 802.11 a, 802.11 b, 802.11 g, and 802.11 n to recognize a couple. In this project we consider 802.11b which works in the 2.4GHz ISM band as When a hub utilizing IEEE 802.11 b as a remote standard wants to send a bundle through the system, it bodes well convention walking around the medium section to oversee (MAC) layer to choose whether or not the Medium is possessed or inactive. These days there are a significant number of projections in which both Bluetooth and Wi-Fi units are gathered and should exist together. Most continuous

ones are Wireless Body Area Networks (WBAN), Smart houses and reasons for the Internet of Things. Conjunction instrument is extremely basic in such inevitabilities to avoid loss of valuable records, for example, human inhabitation or physiological parameters.

IEEE 802.11 and 802.15.4 are two specialized principles for Wireless Local Area Networks (WLANs or the Wi-Fi coalition) and Wireless Sensor Networks. These advancements help in low power and minimal effort correspondence while working in the unlicensed Industrial Scientific and Medical (ISM) band. Unequivocally, IEEE 802.11 works in the 2.4GHz and the 5GHz groups. IEEE 802.15.4 works in 868MHz, 915MHz, and 2.4GHz. Since these innovations work in the unlicensed ISM band, there is no administrative body to organize channel get when the gadgets are gathered. This outcome in whenever channel access by gadgets and yet prompts interference issues.

1.2 Problem description

The objective for this project was to identify the interference occurs in different wireless networks and find the solution to mitigate the interference.

This evaluation should be done theoretically and through simulation. It was also desirable to compare the results with the results for before mitigation and after mitigation in a wireless network. The project also included the goal to generate a simulation environment that could be used as a platform for further studies within the area of the wireless network. This simulation environment should if possible, Wi-Fi analyzer, Wi-Fi SNR and Network manager.

The goal of this project is :

- To Increase signal strength.
- To Decrease signal to Noise ratio.
- To Increase upload and download speed.
- To find the best method for mitigation.
- To Find the best place for wireless device setup.
- To know about the limitations and advantages of interference mitigation.

1.3 Related work

A lot of interference mitigation techniques is already planned [1][3][7][12][17][18] but in them, a little comparisons between the dissimilar techniques have been made. There were many problems which remain unsolved or obscure, and those problems have been tried to be mitigated. There are several added reenactment results[17][18] that have been done on individual conventions. These reproductions have anyway not utilized alike measurements and are in this way not practically identical with one another.

1.4 Disposition

This report consists of 8 chapters. Chapters 1 and 2 explain the causes of interference and different types of wireless technology in the wireless network. Chapter 3 describes about interference and mitigation concepts. Chapters 4 describe about wireless device placement and chapter 5 describe the simulation and the result. Chapter 6 describe the performance analysis and chapter 7 concludes the whole report. Chapter 8 is the references that we have used.

Chapter 2: General Concept

2.1 Wireless technology and wireless interference

2.1.1 Technology

The first professional wireless gadget was produced under the brand ALOHAnet in 1969 at the University of Hawaii and wound up operational in June 1971. The foremost commercial enterprise faraway system used to be the WaveLAN object family, created via NCR in 1986.

- 1991 2G mobile phone organize
- June 1997 802.11 "Wi-Fi" convention first discharge
- 1999 803.11 VoIP mix

A remote framework is a PC arrange that uses faraway information relationship between machine nodes. Wireless frameworks organization is a methodology with the guide of which homes, media interchanges structures and venture organizations keep a key separation from the costly technique for bringing hyperlinks into a building, or as an association between selective equipment zones. Remote communicate interchanges frameworks are in numerous cases realized and coordinated using radio correspondence [7].

This execution happens at the physical measurement (layer) of the OSI show compose structure. Remote frameworks are at the epicenter of this example. At its broadest, a faraway gadget insinuates any gadget never again related by a method for connections, which is the issue that enables the ideal cure and flexibility for the customer. Obviously, given the load various use cases and applications, we should moreover plan to see numerous elite faraway advancements to address the issues, each with its very own execution characteristics and each redesigned for an explicit test and setting. Today, we start at now have more than twelve extensive remote developments being utilized: WiFi, Bluetooth, ZigBee, NFC, WiMAX, LTE, HSPA, EV-DO, earlier 3G benchmarks, satellite television for pc organizations [7] [8].

Occasions of faraway frameworks include phone networks, far away close-by (WLANs), remote sensor networks, satellite correspondence frameworks, and terrestrial microwave frameworks.

Further, while the mechanics of actualities movement through radio correspondence are on an exceptionally straightforward dimension no longer equivalent to the mounted world, the outcome as experienced through the customer might be, or should be, all the equal—same execution, same results. Over the long pull all reasons for existing are and will be passed on over far-flung frameworks; it essentially would conceivably be the circumstance that some will be gotten to additional regularly over remote than others. There is no such thing as a wired application, and there is zero side interest for such a refinement [8].

All capacities should work legitimately paying little plan to shrouded organize. As a customer, we should now not assume about the essential development being utilized, anyway as an option as originators we should think already and modeler our applications to imagine the complexities between the various sorts of frameworks. Additionally, the elevating news is each improvement that we pursue for far-flung structures will suggest the choicest contribution in each setting.

2.1.2 Types of Wireless Networks

A process could be a gathering of devices connected with one another. On account of wireless systems radio correspondence is usually the mode of call. even so even internal the radio-fueled set there are several distinctive enhancements meant for use at varied scales topologies and for appreciably first-rate use cases. one strategy to indicate this distinction is to parcel the employment cases based on their geographic range[10]

Type	Range	Applications	Standards
Personal area network (PAN)	Within reach of a person	Cable replacement for peripherals	Bluetooth, ZigBee, NFC
Local area network (LAN)	Within a building or campus	Wireless extension of wired network	IEEE 802.11 (WiFi)
Metropolitan area network (MAN)	Within a city	Wireless inter-network connectivity	IEEE 802.15 (WiMAX)
Wide area network (WAN)	Worldwide	Wireless network access	Cellular (UMTS, LTE, etc.)

Table 2.1 : Types of wireless network

2.1.3 Wi-Fi (802.11) phy/mac standards :

IEEE 802.11 is a touch of the IEEE 802 strategy of LAN conventions, and chooses the blueprint of media to inspire the chance to control (MAC) and physical layer (PHY) customs for finishing remote neighborhood (WLAN) PC correspondence in different frequencies, including yet not constrained to 2.4, 5, and 60 GHz rehash social affairs.



They are the world's most widely utilized remote PC dealing with benchmarks, utilized in most home and office structures to permit workstations, printers, and PDAs to chat with one another and get to the Internet without accomplice wires. They are made and kept up by the Institute of Electrical and Electronics Engineers (IEEE) LAN/MAN Standards Committee (IEEE 802). The base understanding of the standard was discharged in 1997 and has had coming to fruition remedies. The standard and changes give the acquaint with remote structure things utilizing the Wi-Fi stamp. While every alteration is formally denied when it is consolidated in the most recent variety of the standard, the corporate world will control speaking business sector to the changes since they succinctly suggest cutoff points of their things. Thusly, in the business center, every adjustment will when all is said in done change into its very own unique[11].

802.11a	802.11b	802.11g	802.11n	802.11ac
Ratified in 1999	Ratified in 1999	Ratified in 2003	Ratified in 2009	Ratified in 2013
OFDM modulation	High-Rate DSSS (HR/DSSS)	Extended Rate Physical(ERP)	Uses HT-OFDM	5GHz
5 GHz frequency bands	2.4GHz frequency band	2.4 GHz frequency band	2.4 & 5 GHz frequency bands	frequency only
6-54Mbps	Backward compatible with DSSS(1&2 Mbps	Backward compatible with 802.11b (1-11Mbps)	Backward compatible with 802.11a/b/g(1-54Mbps)	Very High Throughput PHY
	5.5 and 11 Mbps	6-54 Mbps	Up to 600 Mbps	Backward compatible with 802.11a/n
				5 GHz Data rates
				6.93Gbps

Table 2.2: History of 802.11 PHY/MAC standards

2.1.4 Some common causes of wireless interference :

- Leaving the channel number on each radio set to the default esteem can result in high obstruction among the radios on the grounds that an excessive number of radios are sharing the data transfer capacity on one channel
- Hidden hubs in a remote system alluding to hubs that are out of scope of different hubs or an accumulation of hubs. A shrouded hub can create a high number of cyclic excess check (CRC) code blunder.
- Co-channel impedance or contiguous channel obstruction can come about because of setting radios to groups that have covering channels. The channels may not all be being used by her system—neighboring organization signs can likewise cause obstruction.
- Some non-organize gadgets, for example, microwaves, vehicle cautions, cordless telephones, or remote camcorders can meddle with remote stations. Regularly, these gadgets are utilizing the 2.4-GHz recurrence.
- Bad electrical associations can cause wide RF range outflows.
- RF jamming is a deliberate attempt to disrupt the network with a powerful signal
- **Physical articles:** Trees, stone work, structures, and other physical structures are the absolute most normal wellsprings of obstruction. The thickness of the materials utilized in a building's development decides the number of dividers the RF flag can go through and

still keep up satisfactory inclusion. Cement and steel dividers are especially troublesome for a flag to go through. These structures will debilitate or now and again totally avert remote signs. [1]

- **Radio recurrence impedance:** Remote advances, for example, 802.11 b/g utilize an RF scope of 2.4GHz, thus do numerous different gadgets, for example, cordless telephones, microwaves, etc. Gadgets that share the channel can cause clamor and debilitate the signs.
- **Electrical obstruction:** Electrical impedance originates from gadgets, for example, PCs, iceboxes, fans, lighting installations, or some other mechanized gadgets. The effect that electrical obstruction has on the flag relies upon the vicinity of the electrical gadget to the remote passage. Advances in remote advances and in electrical gadgets have lessened the effect that these sorts of gadgets have on remote transmissions.
- **Natural components:** Climate conditions can hugely affect remote flag respectability. Lightning, for instance, can cause electrical impedance, and mist can debilitate motions as they go through.

2.1.5 Sources of interference :

These things can cause impedance with Wi-Fi systems and Bluetooth gadgets in the event that they are close-by. [5]

Microwave ovens

Using the microwave near a PC, Bluetooth device, or Wi-Fi base station may cause check.

Direct Satellite Service (DSS)

The cajole link and connectors utilized with a few kinds of satellite dishes can cause obstruction. Check the cabling for the harm that could cause radio recurrence impedance (RF spillage). Attempt substitution links on the off chance that we speculate impedance. [6]

Power sources

Certain external electrical sources like electrical links, electrical railroad tracks, and power stations can cause impediment. Go without finding wer airplane terminal base station, airPort Time Capsule, or Wi-Fi switch close electrical links in a divider, or just about a breaker box.

2.4 GHz or 5 GHz phones

A wireless telephone that works in the 2.4 GHz or 5 GHz range can cause obstruction with remote gadgets or systems while accepting calls.

Wireless RF video

Remote video transmitters that work in the 2.4 GHz or 5 GHz data transmission can cause impedance with remote gadgets or systems.

Wireless speakers

Remote sound that works in the 2.4 GHz or 5 GHz data transfer capacity can cause obstruction with different remote gadgets or systems.

Certain external monitors and LCD displays

Certain grandstands can exude symphonic impedance, especially in the 2.4GHz band Between channels 11 and 14. This impedance might be more grounded on the off chance that we're using a scratch cushion PC with the best close and have an external screen related. Have a go at changing wer entry to use 5 GHz or a lower 2.4 GHz channel [5][6].

Poorly shielded cabling

Outside hard drives or diverse devices with deficiently secured cabling can interfere with the wireless contraptions. In case disconnecting or murdering the device appears to help, try replacing the connection that relates the device to the PC.

Other wireless devices

Distinctive remote devices that work in the 2.4 GHz or 5 GHz transmission limit (microwave transmitters, remote cameras, newborn child screens, a neighbor's Wi-Fi contraption) can cause deterrent with Wi-Fi or Bluetooth affiliations. A couple of contraptions may not unequivocally express that they work in the 2.4 GHz or 5 GHz band. The thing's documentation should show the gatherings the contraption uses to work. These might be suggested as "Twofold Band" or "Wi-Fi" or "Remote" devices. [5]

2.1.6 Interference From Household Appliances :

An accumulation of family machines can cause remote impedance, including cordless telephones, weth screens, and microwaves. Subordinate upon the masterminding of wer remote change, wer dealt with contraption, and the machine, we may even have the remote structure cleared when the microwave or cordless telephone is being used [6]. Issues with cordless telephones can be fathomed by supplanting wer telephones with telephones that tackle a substitute rehash, for example, 900 MHz or 1.9 GHz. Cordless telephones utilizing the 2.4 GHz rehash will meddle with wireless structure issues with microwaves can consistently be handled by arranging the contraptions to such a degree, to the point that the microwave isn't between the switch and the device. it's similarly possible that another microwave will help if the new microwave has better ensuring. Distinctive devices can in like manner cause issues.

Chapter 3: INTERFERENCE & MITIGATION CONCEPTS

3.1 Basic concept:

In this thesis project, there have been identifying different techniques based on the level of coordination required among interfering WPANs. ‘Simple TDMA’ — This is the baseline case where there is no coordination within or among WPANs and no information available regarding interference. In this situation, it is very likely that no time scheduling technique is used since there is no information regarding the presence or details of interference. [10] This can be considered as the baseline case to understand performance degradation caused by interference and performance improvement. when we employ IM schemes.

3.2 Effects of Interference Seen by Clients :

Our network clients might see the results of interference before we do. They might complain of network blockage, but not of data loss. This blockage might not be instantly obvious with low volume data transmission because, if interference is irregular, packets ultimately get through[34]. Therefore, there is no packet loss, just retransmissions that take time. Another probability is that some devices, such as microwaves, reduce throughput without delaying it entirely. Complaints will growth when more users log in, growing data capacity until data loss happens, or when Voice Over IP (VOIP) calls are placed.[13] VoIP requires substantial bandwidth because resending voice is not an option—the result is released or jumpy voice transmission.

3.3 Channel and Interference

Contrasted with alternate sorts of remote correspondences high recurrence correspondence is specifically blurring a direct result of the multi-way spread and bounty of obstruction from the others. obstruction dependably exists in any remote framework. bit blunder rate is profoundly vital for the execution enhancement of the correspondence frameworks. each recurrence channel because of obstructions and blurring indicates a distinctive flag to commotion proportion. in a portion of the recurrence channels, there are more grounded SNR and these channels are progressively appropriate for the transmission. versatile recurrence jumping is an incredible

arrangement and a method that bargains with various sort of obstruction clamor and blurring. for the effortlessness of the work, the attention is just on the impedance as the principle unsettling influence in accomplishing an ideal and reasonable transmission quality and disregards the various aggravation assets for example different commotions and blurring.[15]

3.4 Adaptive Frequency Hopping

Adaptive frequency hopping is a system in which contraptions constantly change their working repeat to keep up a key separation from deterrent from various devices to upgrade substitution execution. afh orchestrates channels as extraordinary or horrendous and adaptively looks over the pool of good channels. terrible channels are the channels with hindrance. utilizing afh is to ricochet simply over great channels which expects to pick the repeat channels that have less hindrance. for using afh there must be a segment to pick incredible and horrible channels. gotten hail quality sign rssi prompts each channel quality to deliver a summary for terrible channels. the structure and guideline of a proposed afh plot are portrayed in [5] tolerating that there is a duplex handset system. the system is a customary repeat bouncing structure which uses different narrowband channels.

3.5 Interference Mitigation Techniques :

- Basic Interference Mitigation Techniques
- Advanced Interference Mitigation Techniques

❖ Basic Interference Mitigation Techniques

- Avoid the Interference
- Make the signal more robust Attempt to Filter the Interference
- Antenna selection
- Shielding

❖ Advanced Interference Mitigation Techniques

- Frequency Hopping Spread Spectrum (FHSS)
- GPS Synchronization
- Beamforming

3.5.1 Mitigating interference with smarter antennas :

The heavenly chalice for Wi-Fi is the capacity to send a Wi-Fi flag specifically to a client and screen that flag to guarantee it conveys the most ideal throughput - all while always diverting Wi-Fi transmissions over flag ways that are known to be spotless without evolving channels. New Wi-Fi innovations that connect dynamic beamforming and scaled down receiving wire exhibits to this wireless antenna. Dynamic, beamforming is another procedure created to adjust the shape and course of RF vitality as it radiates from the AP. [13] These frameworks utilize diverse radio wire designs for each customer, changing reception apparatus designs as issues happen. For example, when the impedance is encountered, a brilliant radio wire can choose a flag design with constriction toward the obstruction, along these lines expanding SINR and hindering the need to bring down the physical information rate. Receiving wire based beamforming utilizes various directional reception apparatus components to make a large number of radio wire examples, or ways, between the AP and customer. RF vitality is presently transmitted over the ideal way that yields the most elevated information rate and least parcel misfortune. Standard Wi-Fi media get to control (MAC) customer affirmations are checked to decide the flagging quality, throughput and parcel mistake rate of a chose way. [12]

Wise reception apparatus exhibits Additionally effectively dismiss obstruction. Since Wi-Fi just enables one client to talk at any given moment, receiving wires not being utilized to transmit information to a given customer can overlook or reject obstruction that would typically restrain Wi-Fi transmissions. This outcomes in huge flag gain up to 17dB now and again.

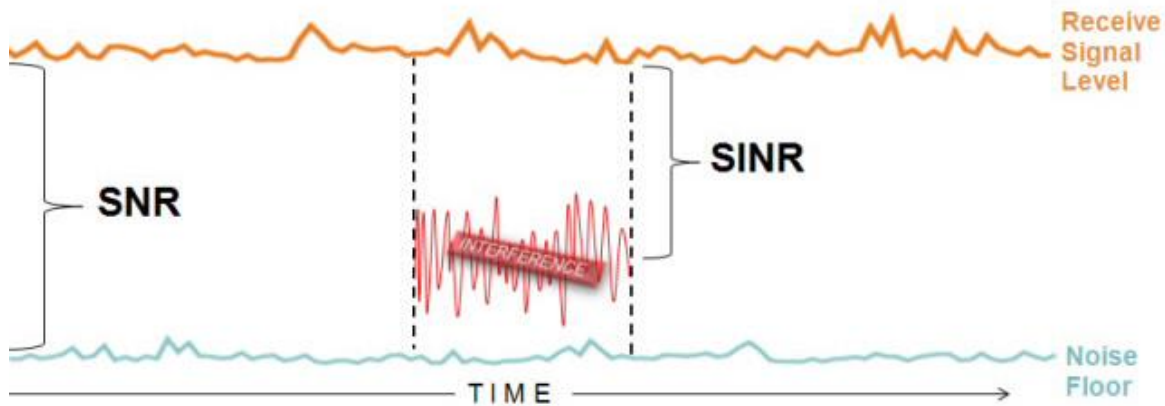

Figure 3.1: SNR signal Ratio Respect With Time

However, maybe the greatest advantage of this new innovation is that it works without manual tuning or human intercession. For system supervisors, relieving RF obstruction is just winding up progressively critical as a surge of new Wi-Fi-empowered gadgets hit venture systems. In the meantime, client desires for progressively solid Wi-Fi associations fit for supporting gushing mixed media applications are soaring.

3.6 Wanted stronger signals and less interference: A typically measurement for foreseeing how Wi-Fi frameworks will perform is the Signal-to-Noise (SNR) Ratio. SNR looks at the contrast between the quality of the get flag level and the commotion floor. Ordinarily, a higher SNR results in fewer piece blunders and higher throughput. However, when impedance tags along system directors have another thing to stress over the Signal-to-Interference in addition to Noise Ratio, Additionally alluded to as SINR.

SINR is the distinction between the flag level and the dimension of obstruction. Given the negative effect of RF obstruction on client throughput, SINR is a greatly improved pointer of what sort of execution can be normal from a Wi-Fi framework. A higher SINR converts into higher information rates and more range limit [34].

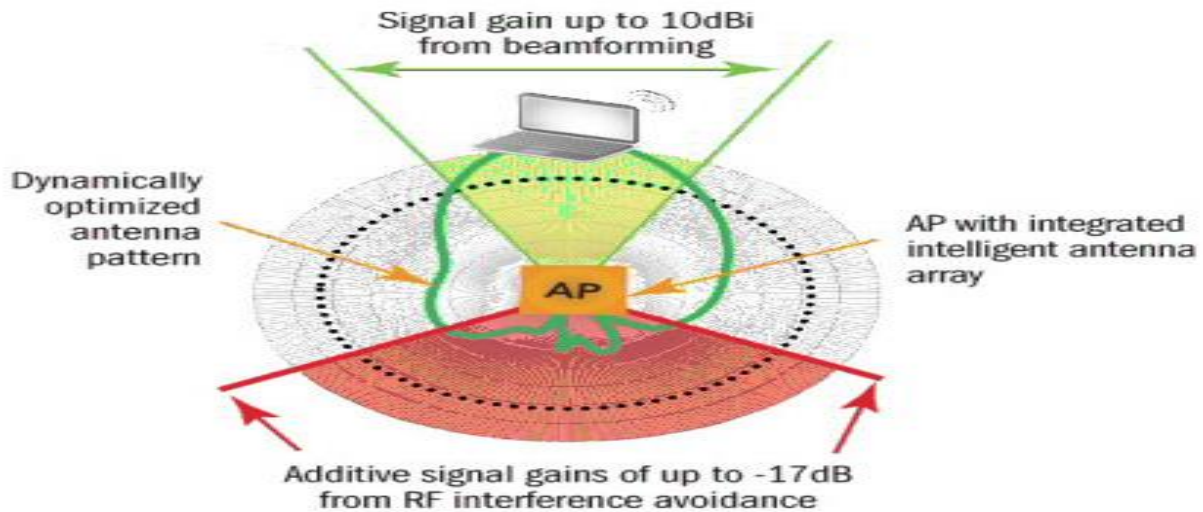

Figure 3.2: Ap with integrated antenna array with SINR (Signal-to-Interference in addition to Noise Ratio)

To accomplish a high SINR, Wi-Fi frameworks should either expand flag gain or decline impedance. The issue is that customary Wi-Fi frameworks can just build flag levels by including more power or by darting on high-increase directional radio wires to their APs which increment gain one way, however, limit inclusion to a littler territory. Late Wi-Fi advancements in the region of versatile radio wire exhibits currently empower arrange directors to get the gain and channel use focal points of a directional receiving wire while as yet covering a similar territory with less Access Point.

3.6.1 Reduce effects of interference from other wireless devices :

In case there are various remote contraptions related with PC or near to, we may need to change the channels used by Wi-Fi devices. To restrain impedance between our Wi-Fi and Bluetooth contraptions, endeavor the going with: [31]

- Change channels on the remote system. For AirPort Base Stations or airport time capsule.
- Reset the base station and it will endeavor to utilize the 2.4 and 5 GHz channels with the minimum obstruction when it begins up.
- Connect to a 5 GHz remote system (if conceivable).
- Move PC and Wi-Fi switch (like AirPort Base Station) closer to one another.

3.6.2 Stop Bluetooth Interference From Messing With Other Devices :

From wireless ergonomic consoles to sans hands headsets, Bluetooth development has in a general sense changed the way in which we work and play. Never again should we misuse significant minutes in our days unwinding wires, and — by a long shot prevalent! — the lion's share of our most adored Bluetooth advancement will coordinate in a minute with any Bluetooth-engaged contraptions. No extended strategies required. There is, just a single little issue. Now and again — and a few seconds ago and again — those Bluetooth contraptions interfere with various advances. In this article we'll examine precisely why this is and make a few suggestions for keeping the greater part of our most cherished devices on extraordinary terms.[7]

3.6.3 How to Stop Frequency Interference :

1. Remove All Barriers: Certain building materials can impede weaker signs like Bluetooth. Metal, impenetrable glass, cement and mortar are especially awful, and marble, mortar and block aren't extraordinary simples. So in case we're extremely battling with impedence, our initial step ought to be to move our Bluetooth gadgets from these materials. That implies no block dividers among us and our gadgets, and unquestionably no metal work areas. [24]

2.Change Router Channel: If we have an Apple switch and we're continually getting obstruction with Wi-Fi, have a go at rebooting it. Upon restart, the station will scan for another channel. In particular, an unexpected direct in comparison to the one Bluetooth gadgets are utilizing to convey. On the off chance that we don't have an Apple switch, we may need to rather go into switch settings and take a stab at changing the channel physically. Try different things with various channels to see which one works best. [23]

3. Move Closer to Router: If we frequently find that we're getting impedence when chatting on a remote headset while on a WiFi call (we'll know since we'll hear static), take a stab at drawing nearer to our switch. This will give us a progressively hearty WiFi association, so the Bluetooth recurrence can't overwhelm it.

4. Get Away From Microwaves and Fluorescent Lighting: Both transmit frequencies of 2.4GHz and moving far from them will separate from the source. The past course of action is neither finished nor completely right. two or three headways and checks start at between times an express use case, like Bluetooth for PAN applications and association substitution, and with time get extra points of confinement, reach, and yield. To be perfectly honest, the latest drafts of Bluetooth beginning at now offer unsurprising cutoff with 802.11 (WiFi) for high-data trade limit use cases. Moreover, advances like WiMAX have their start as settled remote approaches, at any rate with time nonheritable further quality points of confinement, making them a utilitarian various to various WAN and cell improvements [30]

3.7 Proper Attempts to reduce Wi-Fi and Bluetooth interference

Make sense of how to restrict wireless interference that can cause slower execution or separation from our Wi-Fi framework and Bluetooth devices. If we see one of the going with, check for remote impedance: Low signal quality in the Wi-Fi menu [7]

- A slower relationship with the Internet while using Wi-Fi affiliation.
- Intermittent "affiliation lost" messages while using a Bluetooth contraption
- Slower record trades between PCs over Wi-Fi
- Inability to consolidate a Bluetooth device like a Magic Mouse, Magic Trackpad or Apple Wireless Keyboard
- Erratic or "flimsy" pointer advancement while using a Magic Mouse or Magic Trackpad

3.8 GPS Synchronization

It is the procedure of synchronization to GPS that can give nuclear clock accuracy without the need for a nearby by the nuclear clock. everything considered neighborhood nuclear tickers are once in a while required all in all arrangement back-up react in a due request with respect to loss-of-gps either for the condition or an air-related power blackout GPS hindrance or particular conditions.

3.9 Avoid wireless interference using Beamforming

To assemble the upsides of 802.11n improvement it is least difficult to express that there are two huge zones of an overhaul over past 802.11 gadgets. the fundamental space of update is in the utilization of mimo progression to accomplish progressively basic pennant to-commotion degree snr on the radio affiliation. the second area of the overhaul is in the more detectable efficiencies in both radio transmissions. beamforming utilizing the different data different yield mimo approach in 802.11n headway. [11]

The exactness of the synchronization will chooses if the correspondence system can perform well. the beneficiary needs to choose at which time minutes the moving toward sign must be reviewed timing synchronization what more for bandpass trades the authority needs to alter the repeat and time of its neighborhood conveyor oscillator with those of the got banner transporter synchronization regardless a vast part of the present correspondence structures work under opposing conditions.

3.10 Synchronization in Wireless Communications

The latest decade has seen a tremendous addition of remote trades benefits in order to keep pace with the reliably extending enthusiasm for higher data rates joined with higher convenience. to satisfy this enthusiasm for higher data rates the throughput over the present transmission media must be extended. a couple of strategies were proposed to help up the data rate: multicarrier systems to fight specific obscuring ultra-wideband uwb trades structures to grant the range to various customers mimo transmissions to construct the limit of remote associations iteratively decodable codes e.g. turbo codes and ldpc codes to upgrade the idea of the association scholarly radios and so forth to work really the recipient must synchronize with the moving towards the sign. It abuses different frameworks to update the SNR at the expert. one strategy is transmit beamforming. right when there is more than one transmit radio wire it is conceivable to coordinate the flag sent from each recieving wire with the target that the pennant at the specialist is basically made strides. This method is worthy precisely when transmitting to a particular beneficiary transmit beamforming, something that should effortlessly be possible at the transmitter without data from the gatherer about the flag. This examination is accessible just from 802.11 n contraptions not from 802.11b or g gadgets, to escalate the flag at the beneficiary examination from the recipient must be sent to the transmitter so the transmitter can tune every portion it sends.

this information is speedy and genuine for a short time length. Any physical enhancement by the transmitter expert or sections in the earth will rapidly disrespect the parameters utilized for beamforming. the wavelength for a 2.4-GHz radio is just 120mm and 55mm for 5-GHz radio. [7][11]

Hence a typically strolling pace of 1 meter for each second will quickly move the beneficiary out of the spot where the transmitters beamforming attempts are perfect. transmit beamforming is imperative precisely when transmitting to a solitary gatherer. It is crazy to plan to update the season of the transmitted signs when sending confer or multicast transmissions. Along these lines as a rule dealing with applications the utility of transmit beamforming is to some degree obliged giving enhanced SNR at the specialist for just those transmissions that are sent to that beneficiary alone. transmit beamforming can expand the information rate accessible at progressively observable divisions from the ap. In any case, it doesn't mass the joining zone of a way since that is settled in expansive part by the capacity to get the reference centers from the ap. guides are a bestowed transmission that does not profit by transmitting beamforming. Another framework gotten by mimo structure is spatial organized combination which profoundly enhances the snr giving progressively vital flexibility to the WLAN framework creator. A mimo radio sends unmistakable radio standards in the mean time and undertakings multipath. These signs is known as a spatial stream. Each spatial stream is sent from its own unique social event gadget utilizing its very own transmitter. Since there is some space between these receiving wires every flag looks for after a somewhat stand-out way to the recipient. Each radio can in like way send an other information stream from trade radios. The recipient has different social occasion mechanical congregations similarly each with its very own exceptional radio. Each of the get radios freely unwinds the arriving signals. By then each radio gotten standard is joined with the signs from the other get radios. With a gigantic measure of complex math, the outcome is an interminably upgraded get development than can be developed with either a solitary radio wire or even with transmit beamforming. [11]

Chapter 4: Wireless devices placement

4.1 Background

The fundamental of peer to peer topologies and star topology are endorsed by the IEEE 802.15.4 standard. The star topology is normally used in specific areas, such as this one handling is restricted. In the star network, the system operator is responsible for all Spherion, that ensures network communications only one hop range is required. Due to the small operational statement choice of a star IEEE 802.15.4 network, together transmitter and receiver may be impacted during interference periods. So in this case, network communications can be influenced if the default CSMA-CA mechanism miscarries or if the required recognition is wasted [15]. While network infrastructures can come back to usual by allowing the PAN administrator and satellite networks to change to another channel, It's extra helpful now if infrastructures canister can be retained on the on going channel once network switching can not be used, or if interference is also affected by other IEEE 802.15.4 channels.

4.2 Existing Interference Resources

The elementary indication of wireless communication is to offer connectivity over the wireless medium. Thus, wireless schemes are essential to guarantee a sure least broadcast excellence. The metric for computing the broadcast eminence is SNR at the receiver [20]. The noise, is too called interference in this situation, can comprise of several mechanisms, as follows [12]:

1. **Thermal Noise:** The thermal noise is produced by environmental temperature. Pretentious the normal atmosphere temperature is 300 K (around 26 Celsius). The power spectral mass of thermal noise distressing the receiver bandwidth is calculate as 174dBm/Hz.

2. **Man-made Noise:** Manufactured noise could be illustrious into two types:

a) **Spurious emissions:** It is collective for many electric appliances to release noise over a large bandwidth that Includes the variety within which the looked-for wireless communication schemes operate. Car ignitions and other impulse sources are typically example causes of manufactured noise.

b) **Other intentional emission sources:** Several wireless communications schemes in close vicinity purpose in unlicensed bands, particularly ISM 2.4 GHz band. In these bands, all memberships are allowed to emit electromagnetic radiation without restrictions

likened with licensed bands. This interference singularity is serious.

3. **Receiver Noise:** The amplifier and blenders in the receiver are loud and combine parts of noise control in the whole system.

IEEE 802.15.4 WSNs constructed arranged the star topology are suitable for home-based mechanization, personal computer, toys and competitions, and personal health care. These application zones are pretty conjoint in internal use. For example, privileged the home, several homemade appliances including washing machine, radios, televisions, lighting control, reflex screen etc, be able to be systematized using a universal controller [12]. The IEEE 802.15.4 procedure can easily enable these strategies, means wireless without distressing around the alterations of physical appearances. [15]

IEEE 802.11 b constructed wireless local zone systems have become popular in homemade, innovativeness and public admittance zones due to the structures of low cost, simplicity of installation and extraordinary data rates. In areas with both IEEE 802.15.4 and IEEE 802.11 b schemes in the process, difficulties with existence might be reflected. For example, an IEEE 802.15.4 enabled light device node portion a home-based mechanization network is located close to space. A laptop furnished to an IEEE 802.11 b network connector is fixed a couple meters away from the gap and recycled for audio application over the IEEE 802.11 b network. Then the IEEE 802.11 b interference could be harmful to the IEEE 802.15.4 system [12][14][15]

However, these procedures might not be applicable in practical applications due to two motives:

1. The ability of reflex channel swapping to evading interference is not maintained by the IEEE 802.15.4 typical. If the channel shift is compulsory, it should be accepted by application software with the precise interference decision process.
2. IEEE 802.11 b scheme is probably united into portable devices. Therefore, they can work anywhere. However, most IEEE 802.15.4 WSN strategies are still after deployment meanwhile it is not originally planned for mobile applications [14] [15].

4.3 Interference Modeling: Open Loop

Though an IEEE 802.11 method can construct serious interference on an IEEE 802.15.4 receiver, it is still conceivable for the IEEE 802.15.4 to interconnect in the attendance of interference. IEEE 802.11 b wireless statement usually pleases 2 features: non-determination and flexible duty cycle. [7]

4.4 Non-Perseverance

In wireless communication schemes, the broadcasting communication is usually, not determined. Maximum communication protocols postulate the extreme facts payload length for both type of maintained edge. For example, an IEEE 802.11 b MAC edge can cover a maximum of 2304 bytes of data payload. For this case, the quantity of looked-for information is higher than the extreme statistics payload size; the broadcast might be administered packet by packet, which is called datagram destruction. After the completion of a package broadcast, the scheme may be put away about the needed period to regulate the source and course the following edge conceded from the higher layers. Consequently, there is always a convinced interval present among every couple of package broadcasts. [12] [7]

4.5 Adjustable Duty Series

Wireless communication schemes usually effort when essential. For an IEEE 802.11 network, the network could be energetic when operators jump to admittance the Internet and pledge convinced activities. For example, when the operator presses a key on a webpage, the IEEE 802.11 adaptor armed on the computer will lead an appeal to the website by the wireless router, and display to the operator the results when answers are established from the website by the wireless router. The IEEE 802.11 signals travelling among the PC and the wireless access point and generate interference to other wireless communication. Once the procedure of appeal and answer is ended, the IEEE 802.11 network will be slothful until the upcoming process is started. The length of a transmitter-working period is called the responsibility cycle. [19]

According to the level of utilization, the responsibility cycle can be numerous. When the IEEE 802.11 source is idle or in a listening state, there will be no interference. Starting the perspective of system action, this position is called a “low duty-cycle”. It is possible that the communications of the IEEE 802.15.4 scheme will be affected with by powerful IEEE 802.11 signals, but if the period interval between any 2 IEEE 802.11 packages is large enough to enable completion of the IEEE 802.15.4 package broadcast, the result of interference can effectively be mitigated. There are two features that need to be analyzed:

- 1) If the time slot prevailing among two IEEE 802.11 packages is big enough to enable the broadcast of IEEE 802.15.4 packages. [26]
- 2) As per the IEEE 802.11 and IEEE 802.15.4 scheme are unable to interrelate with each other, it is possible to guarantee the IEEE 802.15.4 package broadcasts happens when the IEEE 802.11 scheme is in an idle state. In this episode, an IEEE 802.11 b source is presumed as the interferer.

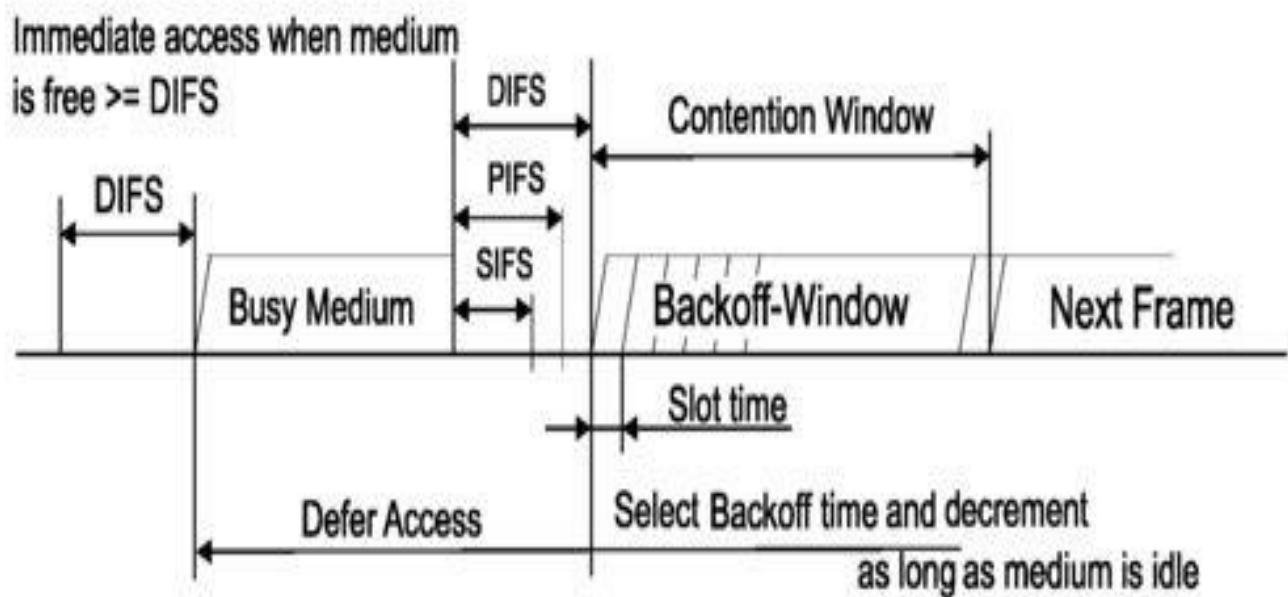

Figure 4.1: Simple access technique of IEEE 802.11 b

In the Figure 4.1 once an IEEE 802.11 b device is to transmit a package, it will monitor the channel until an idle time is equal to or better than a dispersed inter frame space (DIFS) is sensed. If the channel is full, the device will retain submitting. After identifying an idle DIFS, the device selects a casual amount of "slot time" (*aSlotTime*) and jumps to back off, which means the device waits for a indicated time before initiate the transmitting procedure. Once the back off pledge touches zero, the device initiate to transmit the package. If the channel is sensed to be full during the time of back off, the amount temporarily suspends and restarts when a time of idle DIFS is noticed. [15]

The interference analysis here stresses the result of interference temporary on the IEEE 802.15.4 standard. An exposed loop analysis is suitable to analyze the interference at the IEEE 802.15.4 receiver while avoiding the relations among the IEEE 802.15.4 scheme and interferer system. Figure 4.1 illustrates an assessment of IEEE 802.11 b and IEEE 802.15.4 broadcast events on the base of the similar period stroke. [13]

4.6 Valuation Test

The valuation test is intended to evaluate if the scheme is active for an IEEE 802.15.4 network to accomplish operational transportations through the time of interference. The hardware deployment for the evaluation test is similar to that cast-off for the base line test II. additional laptops are added to the arrangement for create more wireless traffic. Figure 4.2 shows the deployment. [28][29]

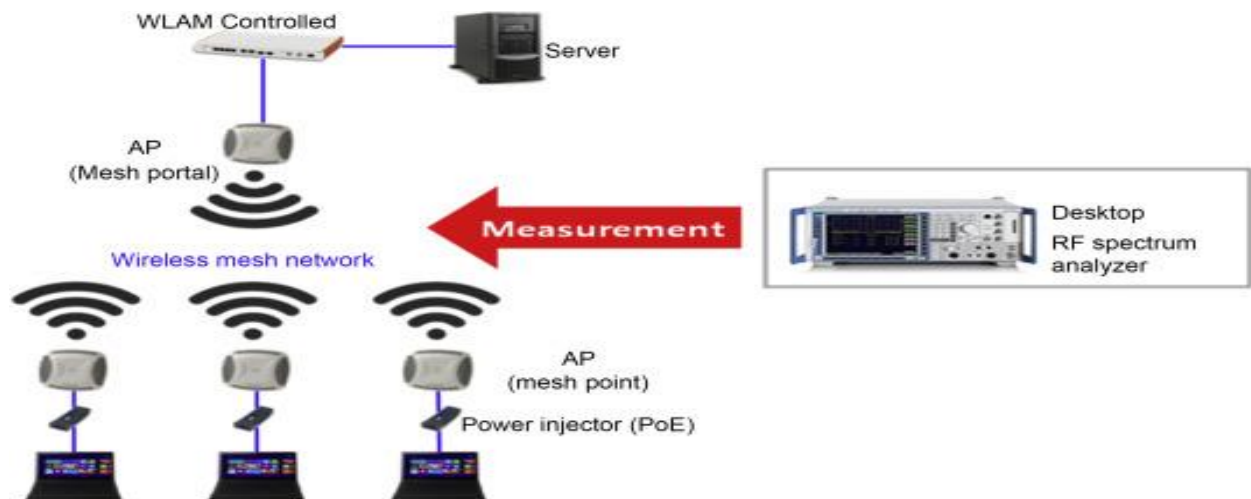

Figure 4.2 : Device deployment for valuation test

The principal variance among the outcomes found with and without 802.11 b interference mainly happens at the fact where no speed limitation is applied to the IEEE 802.11 b traffic. For facts packages sent by the PAN coordinator, if no approach is applied, the sophisticated data payload covers the lower successful rate is found. Aimed at example, when no speed limitation is applied to the IEEE 802.11 b circulation, and if data payload is two bytes, the accomplishment amount is 53.8%. If the data payload is 102 bytes, the victory rate is 23%. When IEEE 802.11 b traffic is slower, the accomplishment rate of data broadcast without approach implementation is slightly less than the victory rate with approach implementation. No data broadcast is lost when the approach was applied as the scheme utilizes successive retransmission to certify connectivity. For the additional settings of IEEE 802.11 b circulation, the successful charges for each of the two states were similar. [26][27]

Although the 3 typically non-overlapping channels detailed in the description of IEEE 802.11 b have been employed by the 3 Wi-Fi access point used in the evaluation test, the PAN coordinator is still able to switch the last 2 IEEE 802.15.4 channels (channel 25 and 26) which are isolated from the consequence of the IEEE 802.11 b communication channels. This is the reason why only one channel adjustment was desirable through the test. According to the opinion through the evaluation test, the extreme IEEE 802.11 b data rate visits at about 500-600 KBytes/s, which is assumed to be near to capacity in a practical situation, Therefore, the PAN coordinator has to retransmit several periods so that preserve communications when the

802.11 b traffic is limited. The PAN coordinator might still essential to retransmit a couple periods, but there is no necessity to shifting the channel.[27]

4.7 Beat Wi-Fi Interference with “NetSpot”

Each time we are experiencing some issues with the wireless sign NetSpot will assist us to decide whether or not wi-fi interference is taking place. NetSpot can display us what wi-fi channels the networks round are the usage of and may give us advice what channel is the fine alternative for our network. With NetSpot we will stroll the perimeter and decide the weakest spots for your WiFi and the most powerful [17].

The WiFi overall performance will always stand right down to that one in all a stressed community. However, it keeps getting higher every year and the gap will become much less and much less between the two.

A twin band 802.11ac router can supply us the satisfactory WiFi overall performance especially when placed successfully. set up multiple routers in bridge mode on unique degrees of a constructing to enhance WiFi signal even extra [17] [18].

4.7.1 Netspot And Its Functions

NetSpot is a software program tool for wireless community assessment, scanning, and surveys, analyzing the wi-fi coverage and overall performance. It runs on Mac OS X 10.6+ and Windows 7-eight-10 and helps 802.11n, 802.11a, 802.11b, and 802.11g wireless networks. NetSpot makes use of the same antique wi-fi community adapter and its Airport interface to map radio signal power and unique community parameters, and construct reviews on that. NetSpot launched in August, 2011 [18].

Functions :

NetSpot presents all efficient wi-fi website survey capabilities for wireless and maps insurance of a residing location, workplace area, buildings, etc. It gives visual information to help analyze radio signal leaks, learn noise resources, plot channel use, improve get entry to factor locations. Also, the software can carry out wi-fi community making plans: the information which might be amassed assist to choose channels and placements for new hotspots. Investigation reviews can be produced in PDF layout [17].

Usual Uses :

- Drawing Wi-Fi signal strength
- Enhancing networks
- Trouble-shooting networks
- Visualizing wireless networks
- Analyzing signal problems
- Analyzing wireless network coverage

4.7.2 How Netspot Works

- A utility that offers multiple tools to map and identify the network strengths and weaknesses.
- Netspot can scan an area and identify the quantity and strength of all access points in Range.
- Netspot provides two ways of measuring the wifi signal strength.
- NetSpot helps to determine whether wireless interference is taking place.
- Netspot provides the best wireless channels for the selected network

4.7.3 Discover Mode :

NetSpot collects every detail about surrounding Wi-Fi networks and present wireless data as an interactive table. It lets you troubleshoot and enhance network's coverage, capacity, performance, APs configurations, signal level, interference, noise, etc [17].

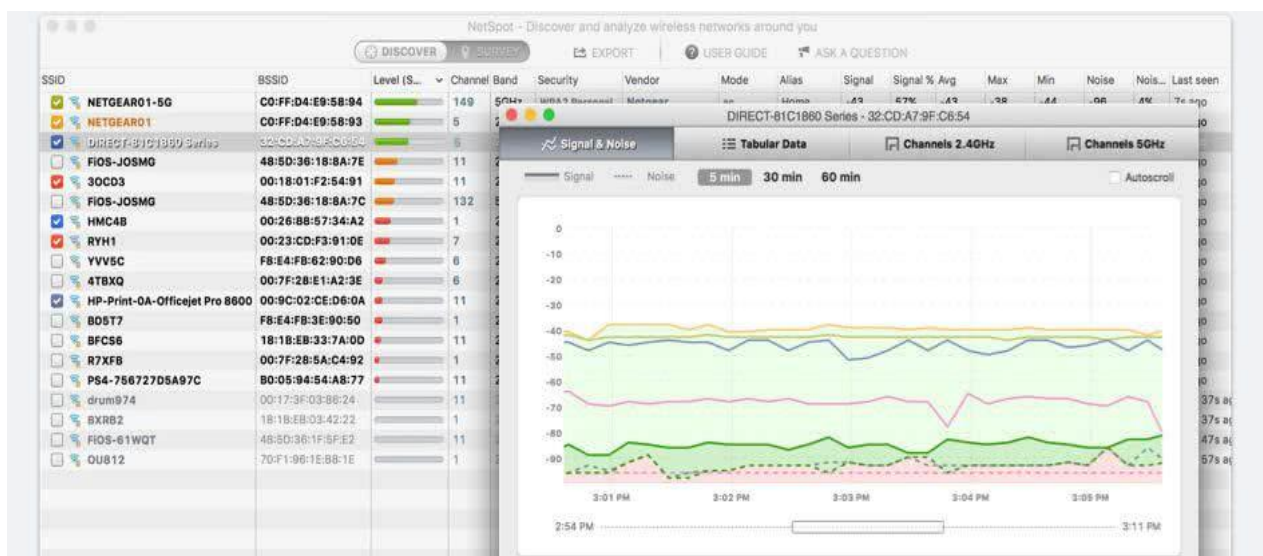

Figure 4.3: wi-fi analyzing with Netspot in discovery mode

4.7.4 Wi-Fi Surveys

By NetSpot, the in-distance network analysis is a draft, cheers to its collaborating color-coded heat maps. Outline our real-life Wi-Fi data on a chart quickly and easily. Flexible professional reports included [18].

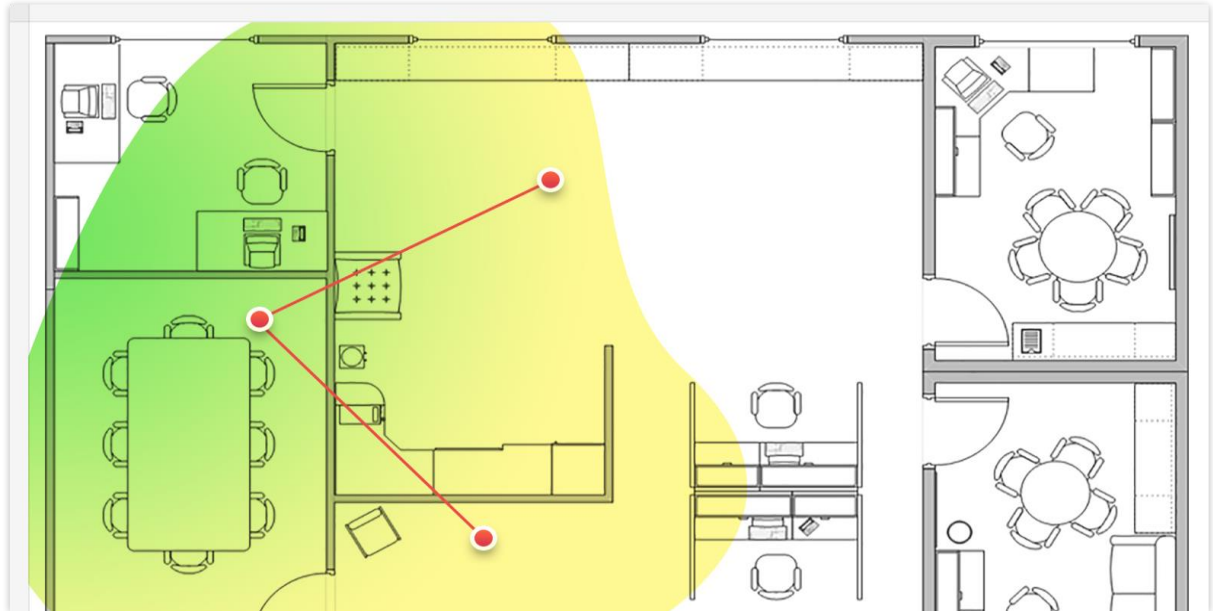

Figure 4.4: wi-fi analyzing with Netspot in survey mode

Chapter 5: Simulation and Result

5.1 Interference Occurs:

In this figure 5.1, we designed a ground floor wireless topology where the access point is in the lounge. A user is connected with this access point from a particular room. So when access point transfers a signal, there are diffraction, reflection and scattering occurs before the user receive the signals. So for these causes interference occurs. In this situation the power of the signal strength is going to be low, which we can see from the figure:5.2(a),5.2(b),5.2(c) for both channel strength and time strength graph. By using speed meter we found that the download speed is 2.46Mbps, upload speed is 3.68Mbps the ping value is 2.17 ms, which we can see from figure 5.3.

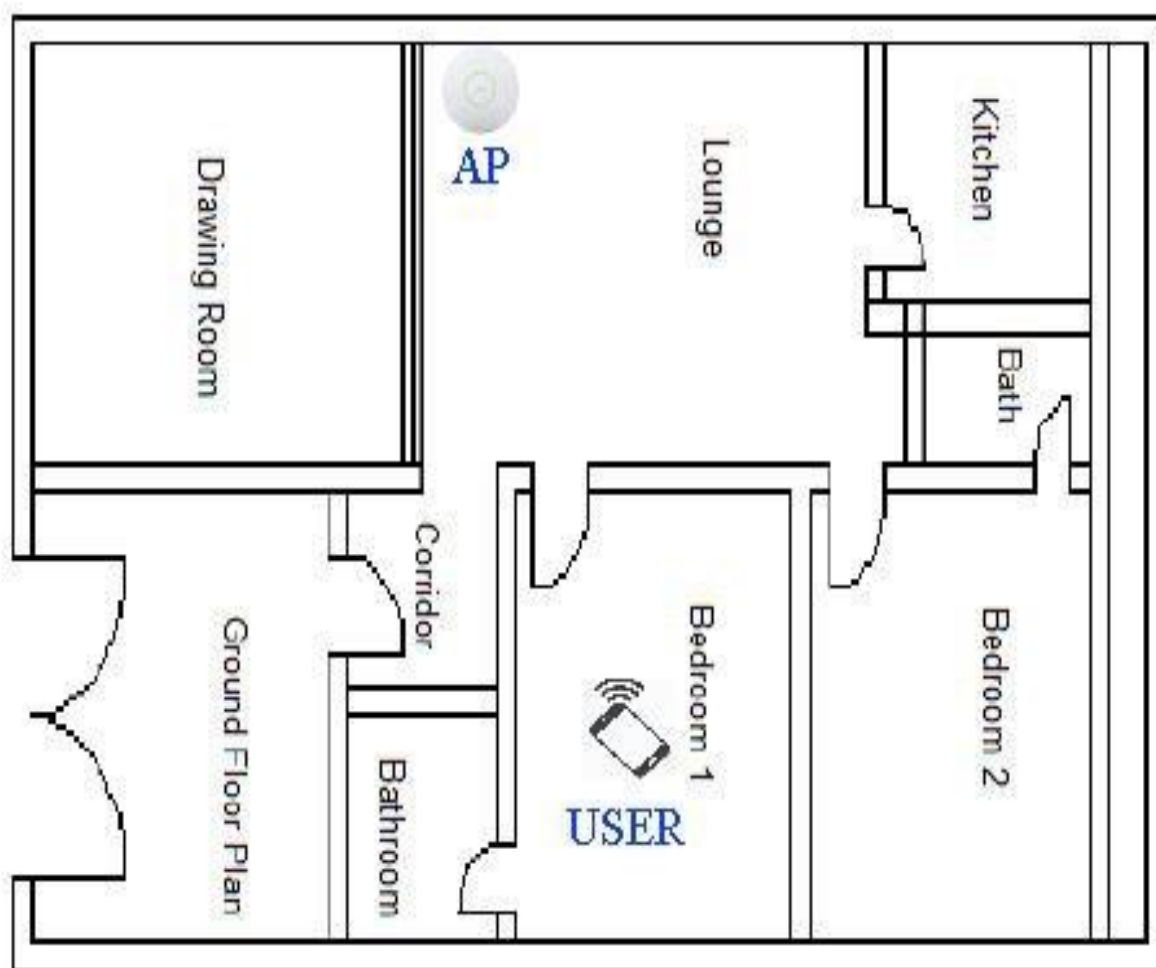
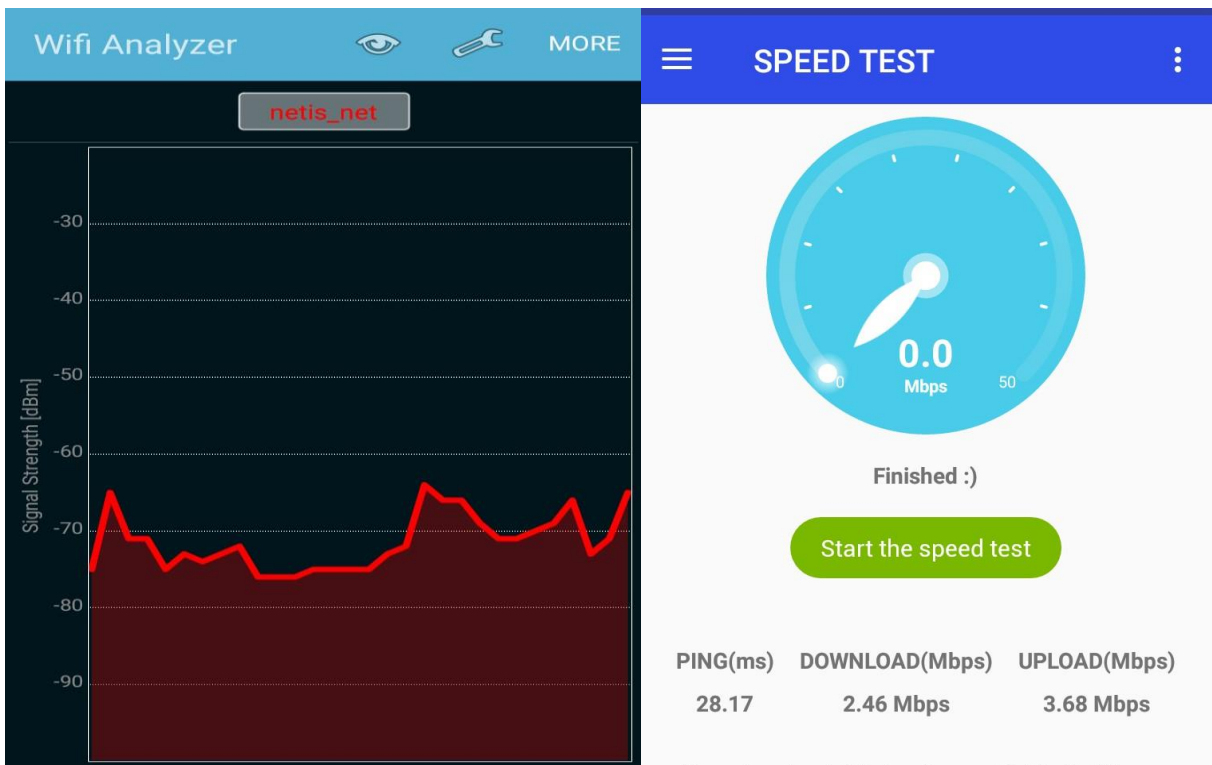
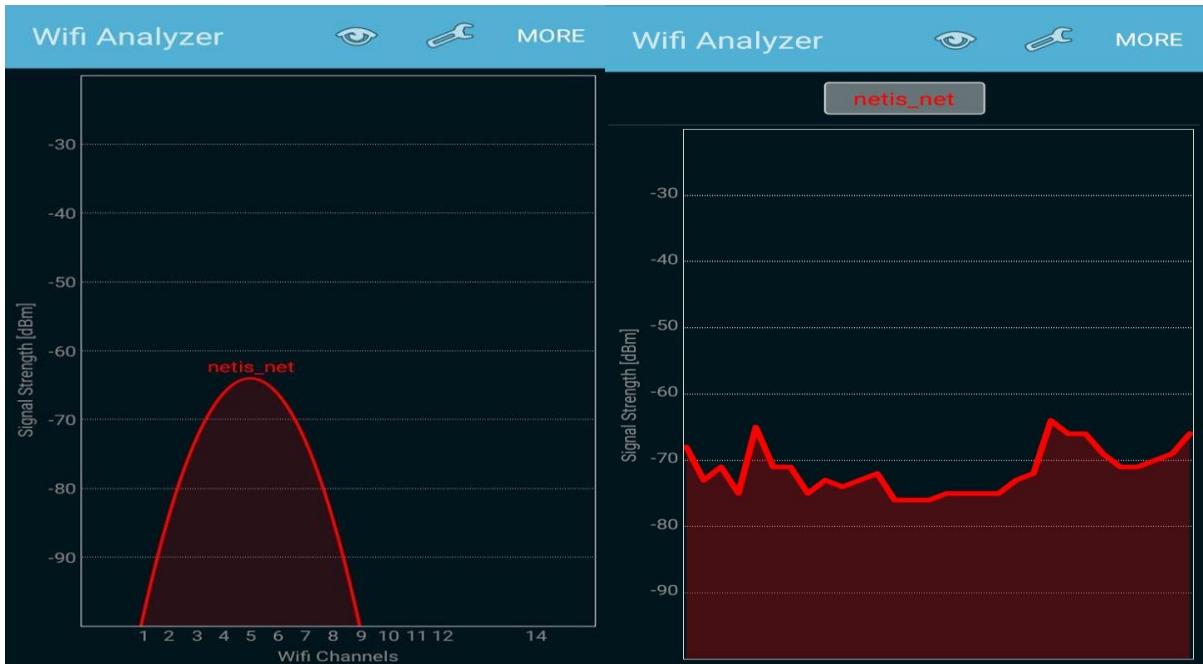

Figure5.1: Ground Floor Wireless Topology



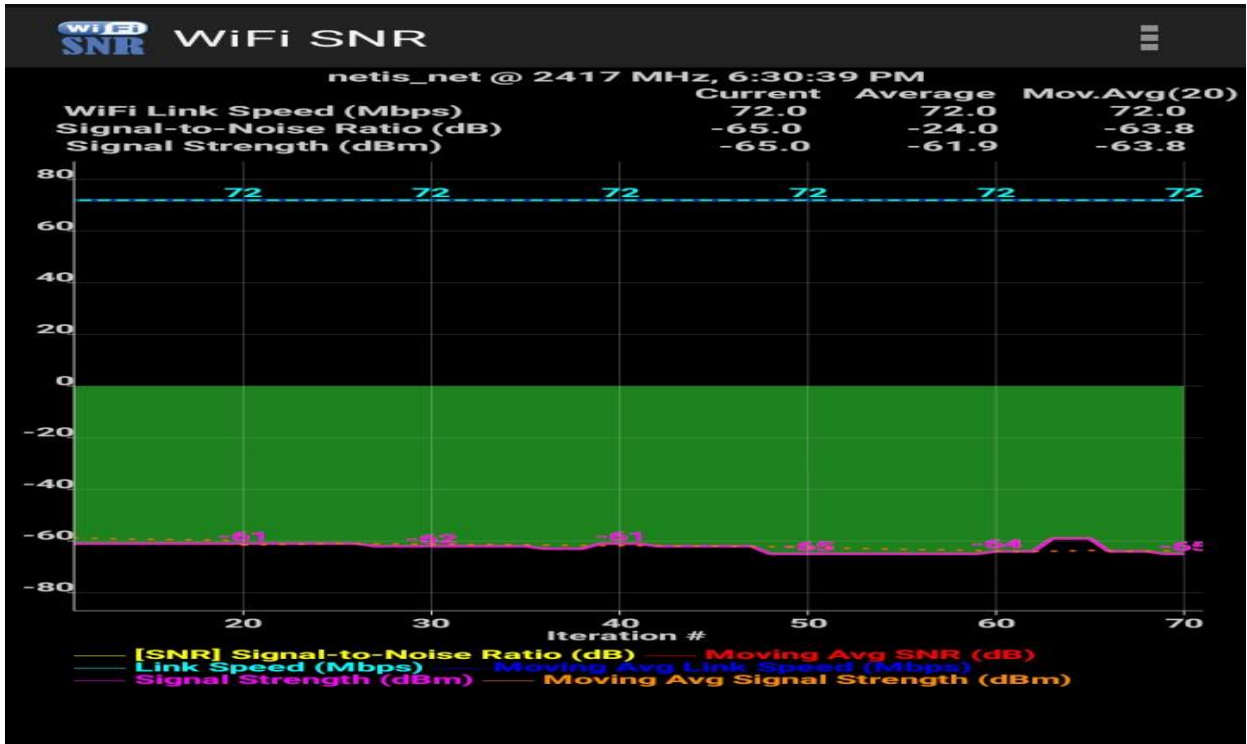

Figure 5.4: Wi-Fi SNR (Signal To Noise Ratio) Graph

From figure 5.3 and figure 5.4 we get these values below the table:

Signal-to-Noise Ratio(dB)	-65.0 dB
Link Speed(Mbps)	72.0 Mbps
Signal Strength(dBm)	-65.0 dBm
Signal-to-Noise Ratio Average(dB)	-24.0 dB
Link Speed Average Average (Mbps)	72.0 Mbps
Signal Strength Average (dBm)	-61.9 dBm
Ping(ms)	28.17 ms
Download(Mbps)	2.46 Mbps
Upload(Mbps)	3.68 Mbps

Table 5.1: Values Of Before Interference Mitigation

5.1.2 Avoid Interference:

To mitigate the interference, the first step is to avoid interference. So in this same topology of figure 5.5, if we want to avoid the interference, the user should move to near the access point or user should keep an access point in his location.

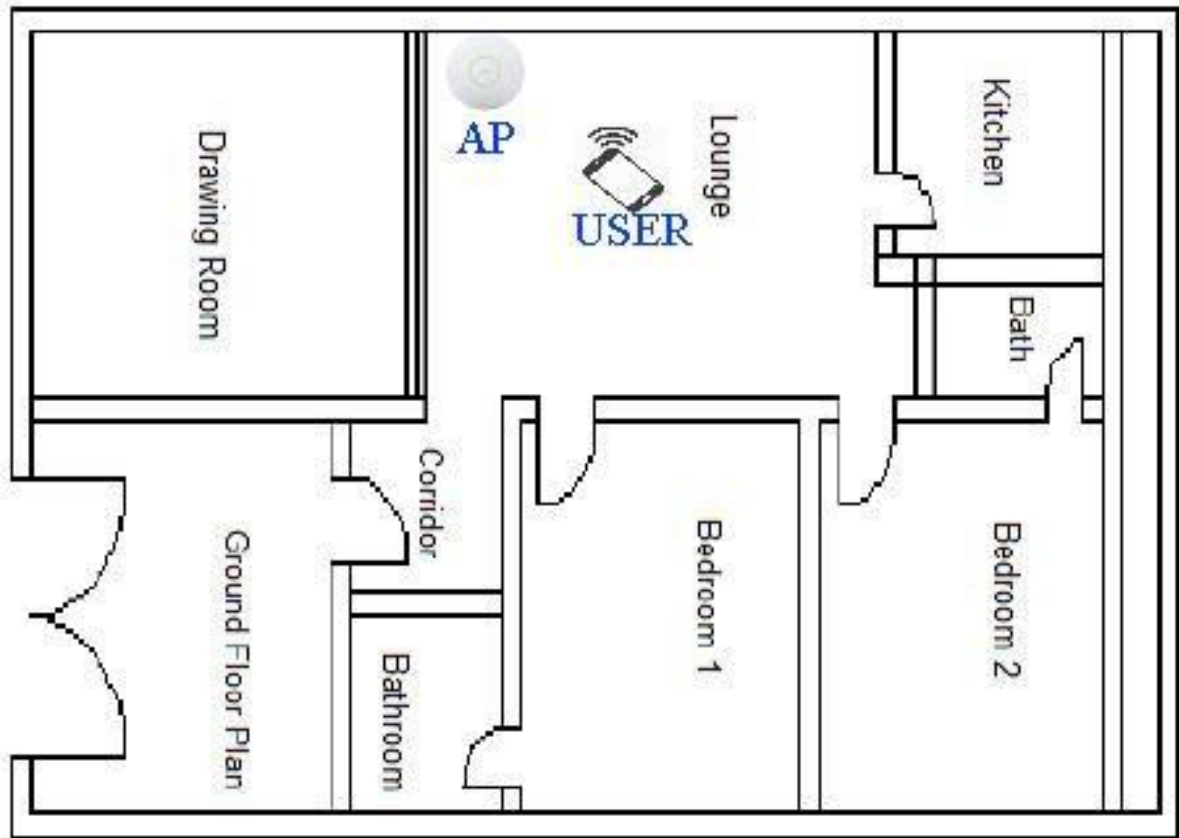

Figure 5.5: Ground Floor Wireless Topology (Near To AP)

The access point should be kept there from where light can give proper lighting in the whole space. When a user is near the access point then a negligible interference occurs. In this situation the power of the signal strength is going to be high, which we can see from the figure 5.6(a),5.6(b),5.6(c) for channel strength graph. By using speed meter we found that the download speed is 3.58 Mbps, upload speed is 3.71Mbps the ping value is 125.74 ms, which we can see from figure 5.7.

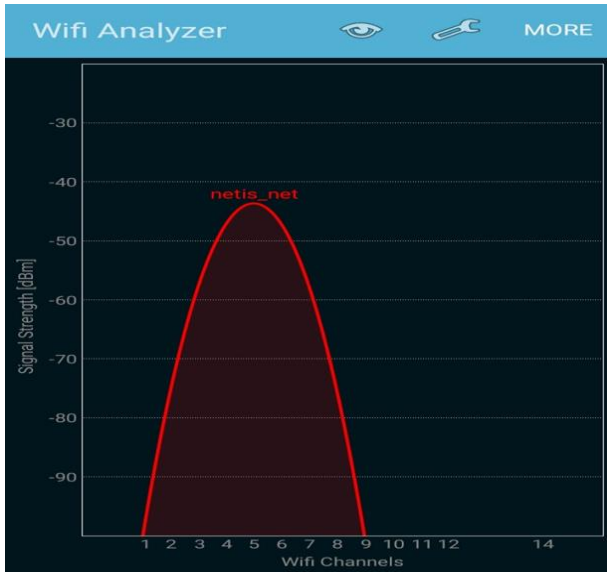

Figure 5.6(a) Channel Graph

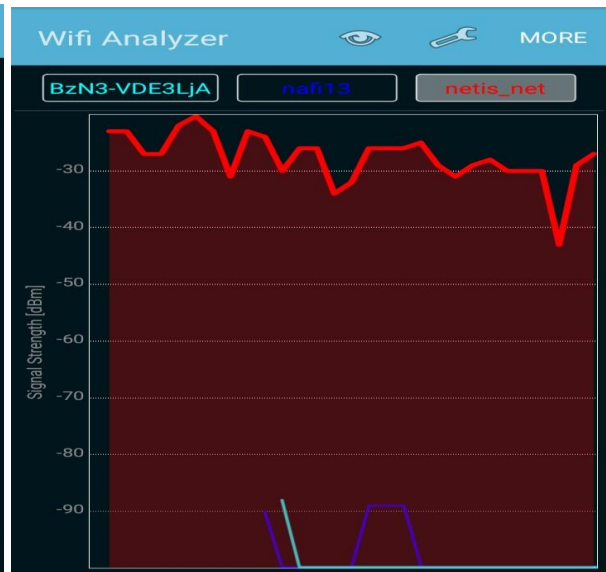

Figure 5.6(b) Time Graph (1)

From figure 5.6(b) and figure 5.6(c), we observed when two signals are overlapping the signal strength is become down and when the overlapped signals are eliminated the signal strength is become high. From this scenario, we understood that for overlapping occurs interference. So we can Say that avoid the interference also a term to mitigating the interference.

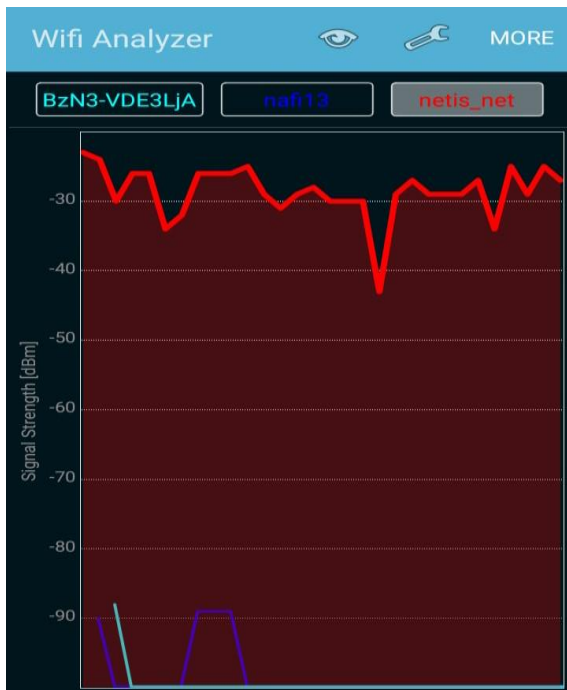

Figure 5.6(c) Time Graph (2)

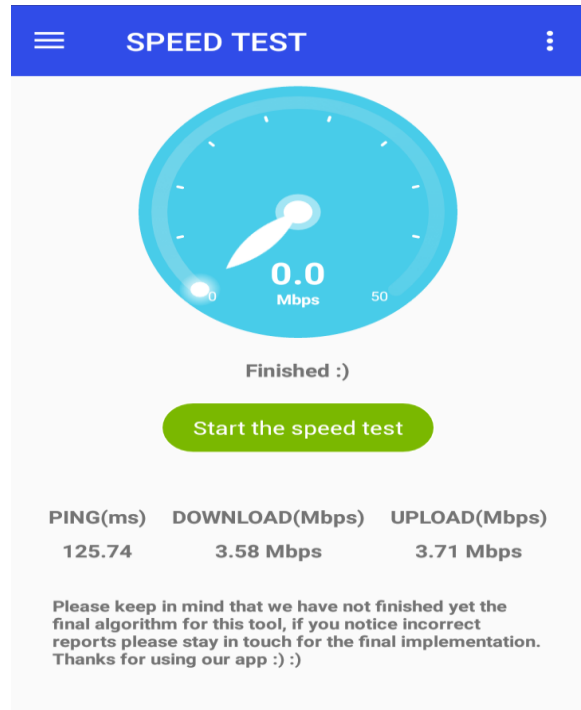

Figure 5.7 Speed test (Avoiding Interference)

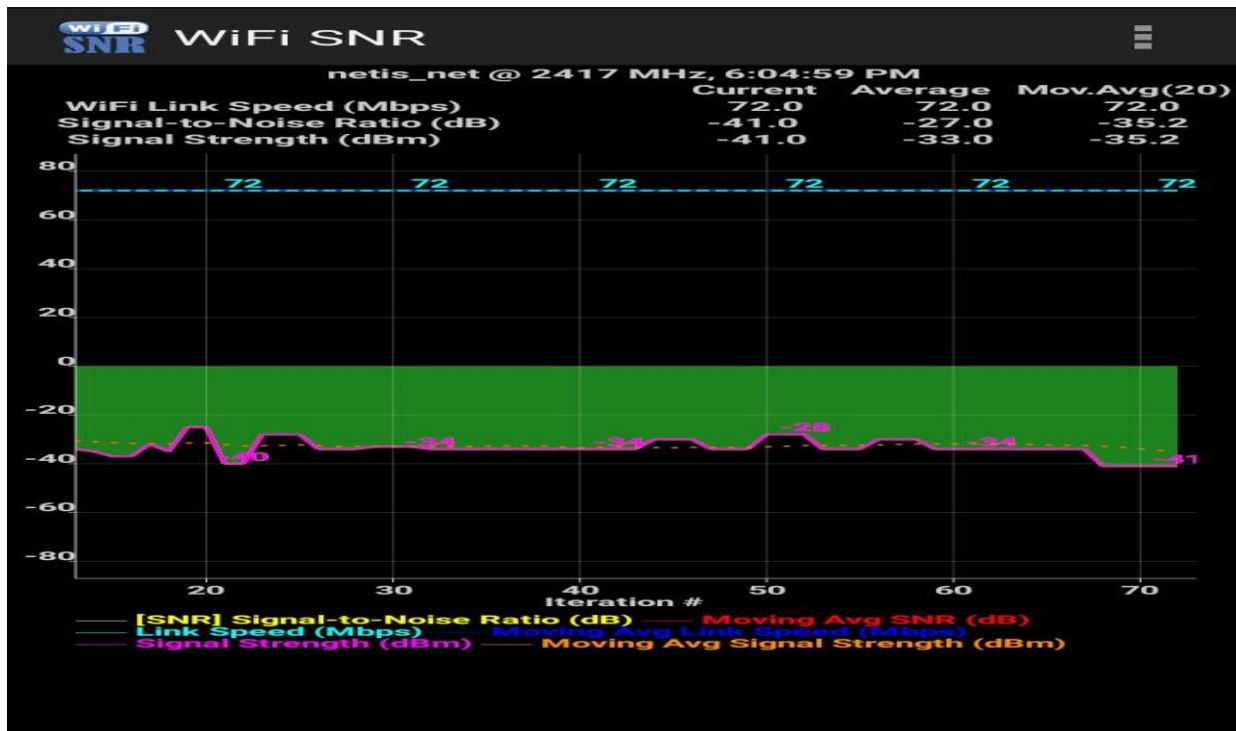

Figure 5.8 Wi-Fi SNR (Signal To Noise Ratio)

From figure 5.7 and figure 5.8 we get these values below the table:

Signal-to-Noise Ratio(dB)	-41.0 dB
Link Speed(Mbps)	72.0 Mbps
Signal Strength(dBm)	-41.0 dBm
Signal-to-Noise Ratio Average(dB)	-27.0 dB
Link Speed Average Average (Mbps)	72.0 Mbps
Signal Strength Average (dBm)	-33.0 dBm
Ping(ms)	125.74 ms
Download(Mbps)	3.58 Mbps
Upload(Mbps)	3.71 Mbps

Table 5.2: Values Of Avoiding Interference

5.2 Overlapping :

The overlapping problem occurs in both time and frequency domains. By selecting the accurate Wi-Fi channel can significantly improve the Wi-Fi coverage and performance. Overlapping signals separation is a difficult problem, where time windowing is unable to separate signals overlapping in time and frequency domain filtering is unable to separate signals with overlapping spectra.

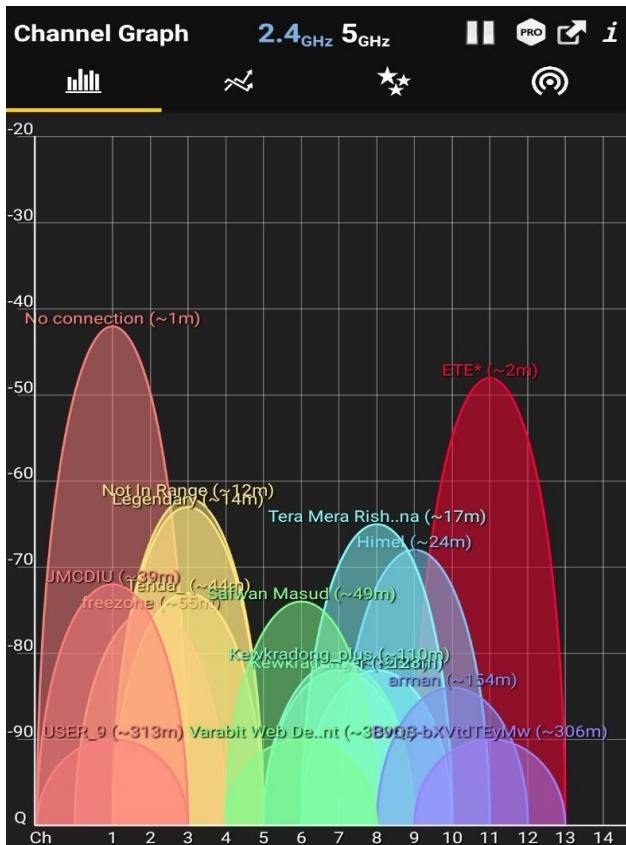

Figure 5.9 Channel Graph

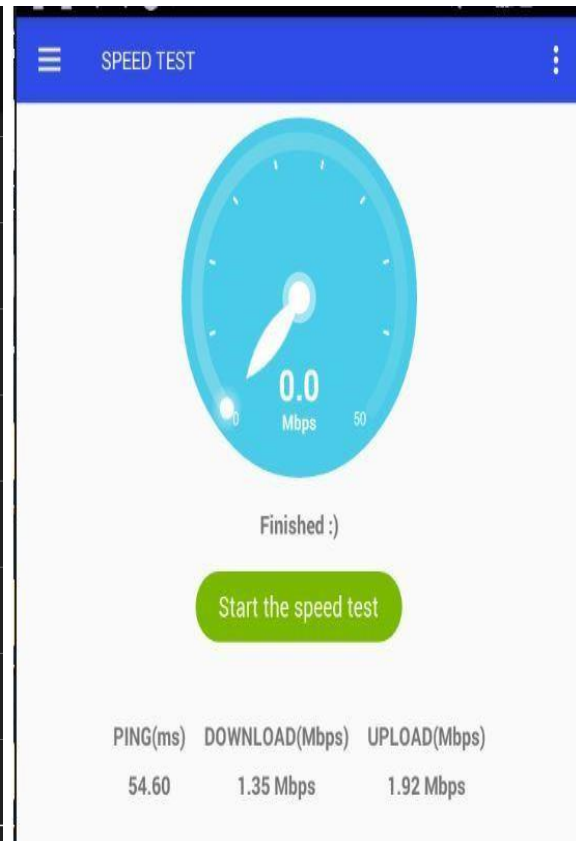

Figure 5.10 Speed Test (Overlapping)

In figure 5.9, 5.10, 5.11 after observation, we understood that for channel overlapping and frequency overlapping interference occurs. If we can avoid these overlapping, we can mitigate the interference.

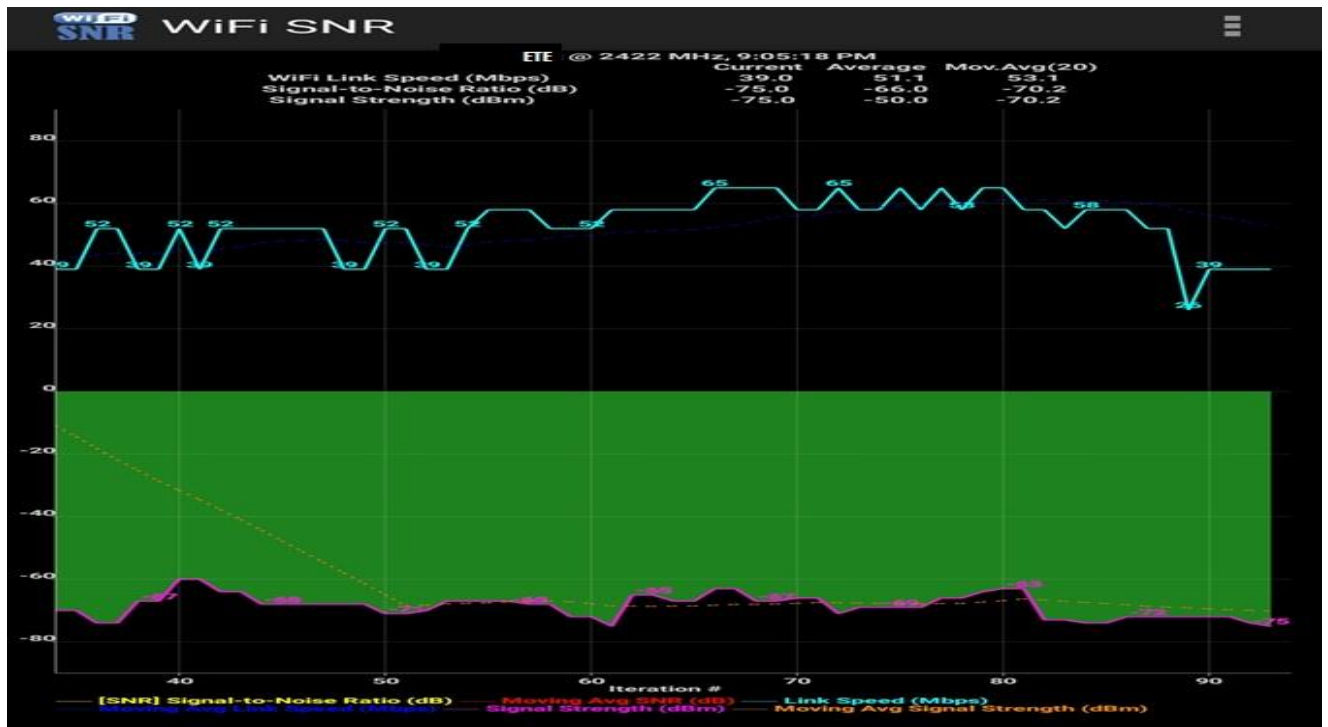

Figure 5.11 Wi-Fi SNR (Signal To Ratio)

From figure:10 and figure:11 we get these values below the table:

Signal-to-Noise Ratio(dB)	-75.0 dB
Link Speed(Mbps)	39.0 Mbps
Signal Strength(dBm)	-75.0 dBm
Signal-to-Noise Ratio Average(dB)	-66.0 dB
Link Speed Average Average (Mbps)	51.1 Mbps
Signal Strength Average (dBm)	-50.2 dBm
Ping(ms)	54.60 ms
Download(Mbps)	1.35 Mbps
Upload(Mbps)	1.92 Mbps

Table 5.3: Values Of When Overlapping Occurs

5.2.1 Channel Change to mitigate The interference:

Generally, in a home environment or Industrial environment, we use multiple access point. When all the access points channels are same then the interference occurs. To avoid this interference we should choose the channel where a minimum number of the access point is used.

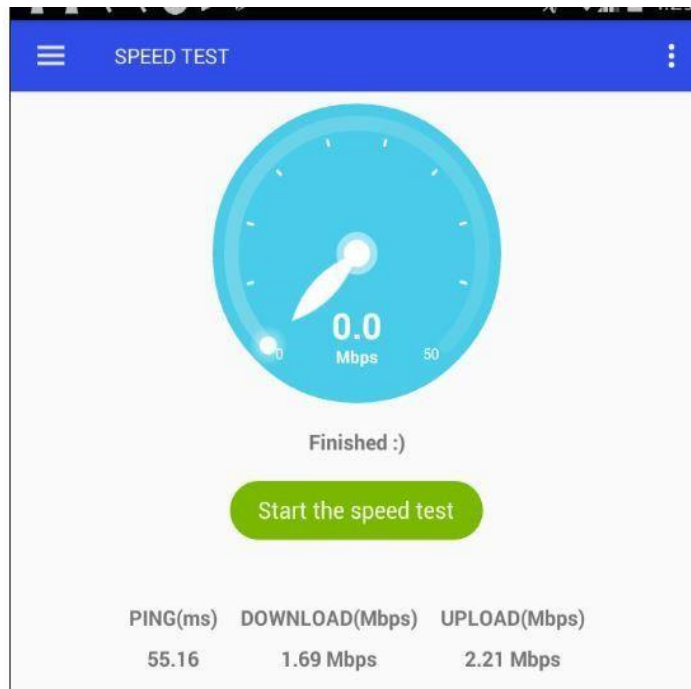

Figure 5.12: Speed Test (Channel-Changing)

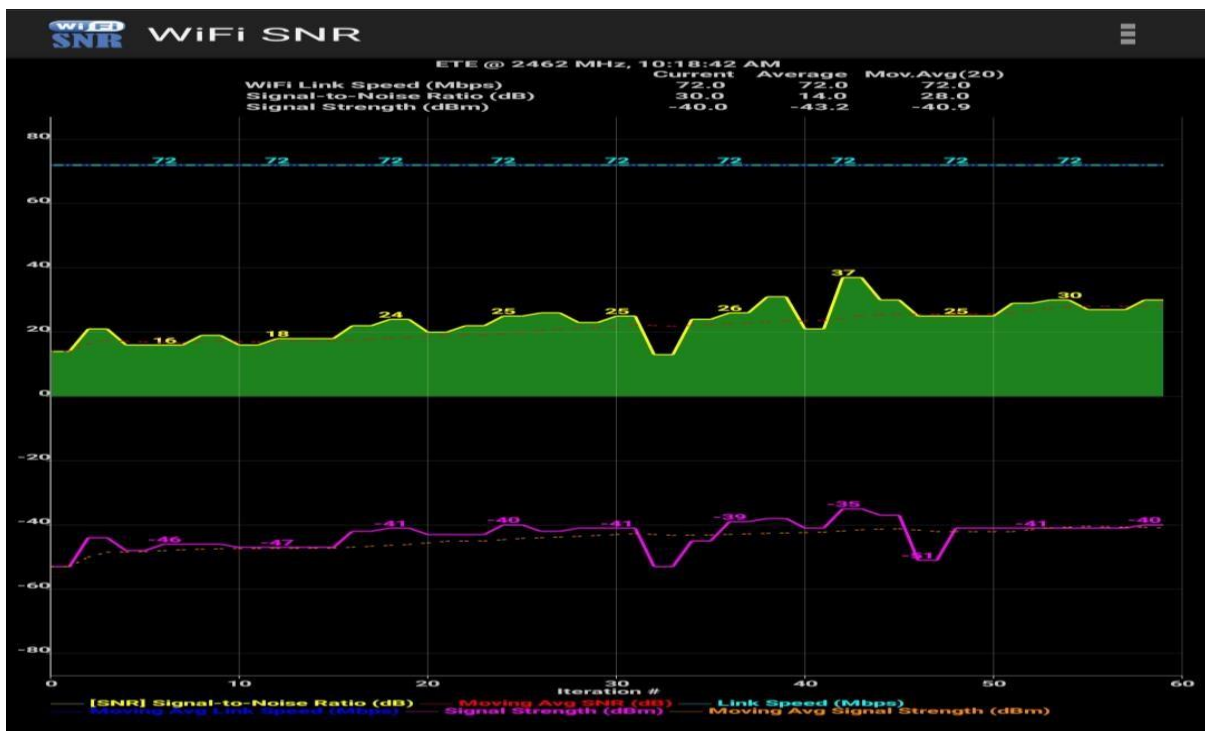

Figure 5.13: Wi-Fi SNR (Signal To Noise Ratio)

From figure 5.12 and figure 5.13 we get these values below the table:

Signal-to-Noise Ratio(dB)	30.0 dB
Link Speed(Mbps)	72.0 Mbps
Signal Strength(dBm)	-40.0 dBm
Signal-to-Noise Ratio Average(dB)	14.0 dB
Link Speed Average Average (Mbps)	72.0 Mbps
Signal Strength Average (dBm)	-43.2 dBm
Ping(ms)	55.16 ms
Download(Mbps)	1.69 Mbps
Upload(Mbps)	2.21 Mbps

Table 5.4: Values Of Channel Changing

5.3 5GHz Frequency Band Use To Avoid Interference:

Most of the normal access points like TP-LINK, TENDA, NETIS, ASUS, etc are uses 2.4GHz frequency band. Its very natural to occur interference if we use the same frequency band access point.5GHz frequency band access point is not used available. If we use 5GHz frequency band access point there is no change the to overlapping with 2.4GHz frequency band access point.

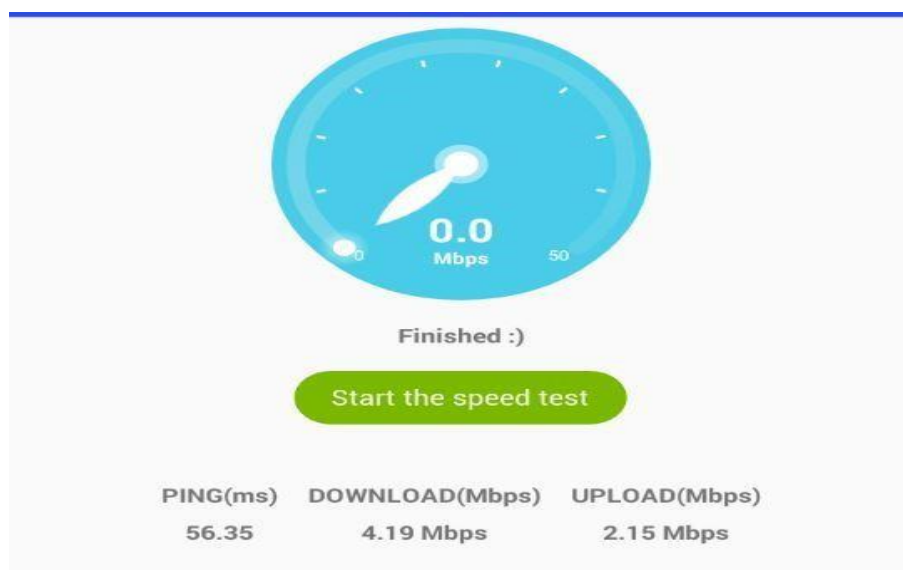

Figure 5.14: Speed test Of 5GHz Frequency Band

Here we observed that when we change frequency 2.4GHz to 5GHz, the download and upload speed become increasing. So we say that mitigates the interference.

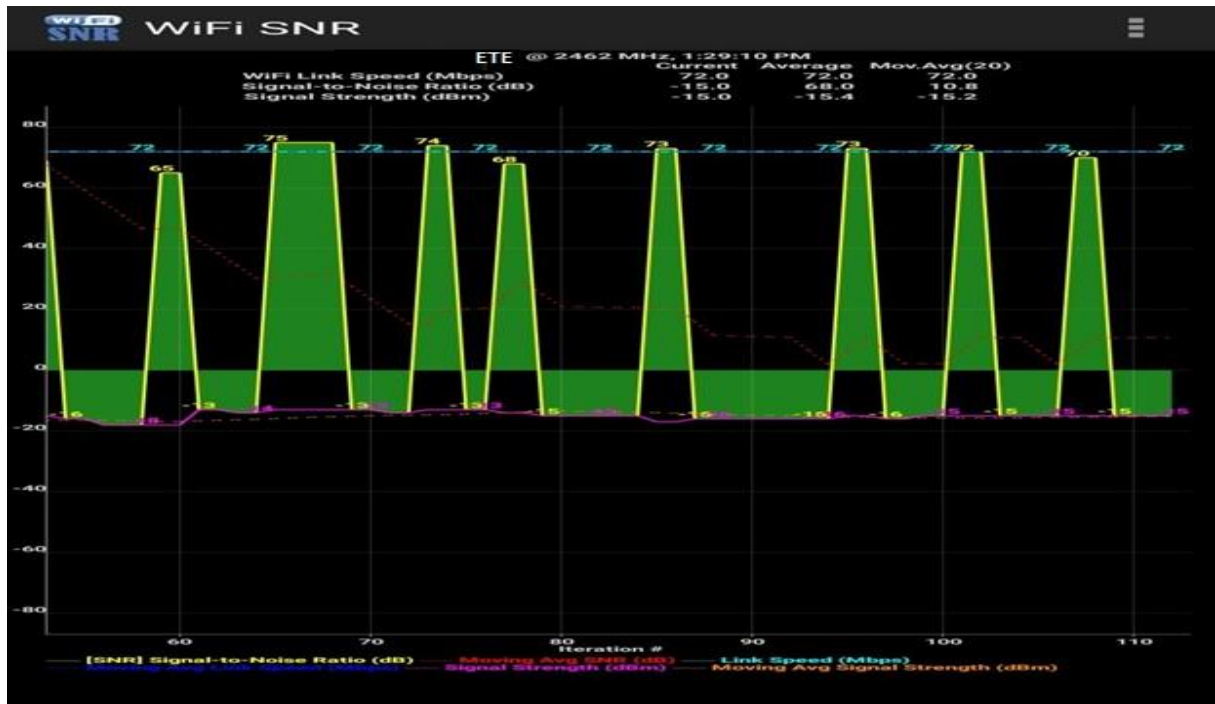

Figure 5.15: 5Ghz Frequency Band Wi-Fi SNR (Signal to Noise ratio)

From figure:14 and figure:15 we get these values below the table:

Signal-to-Noise Ratio(dB)	-15.0 dB
Link Speed(Mbps)	72.0 Mbps
Signal Strength(dBm)	-15.0 dBm
Signal-to-Noise Ratio Average(dB)	68.0 dB
Link Speed Average Average (Mbps)	72.0 Mbps
Signal Strength Average (dBm)	-15.4 dBm
Ping(ms)	56.35 ms
Download(Mbps)	4.19 Mbps
Upload(Mbps)	2.15 Mbps

Table 5.5 : Values Of 5GHz Frequency Band

5.4 Result:

Below the table shows the difference between Before mitigation and After Mitigation Interference:

Method		Before Mitigation	After Mitigation	Percentage
Avoid Interference	Signal-to-Noise Ratio(dB)	-65.0	-41.0	36% reduce
	Signal Strength(dBm)	-65.0	-41.0	36% reduce
	Signal-to-NoiseRatio Average(dB)	-24.0	-27.0	12.50% increase
	Signal Strength Average(dBm)	-61.9	-33.0	46.69% reduce
	Ping(ms)	28.17	125.74	346.36% increase
	Download(Mbps)	2.46	3.58	45.53% increase
	Upload(Mbps)	3.68	3.71	0.82% increase
Channel Change to mitigate The interference	Signal-to-Noise Ratio(dB)	-75.0	30.0	140% reduce
	Signal Strength(dBm)	-75.0	-40.0	46.67% reduce
	Signal-to-Noise Ratio Average(dB)	-66.0	14.0	121.21% reduce
	Signal Strength Average(dBm)	-50.2	-43.2	13.94% reduce
	Ping(ms)	54.60	55.16	1.026% increase
	Download(Mbps)	1.35	1.69	25.19% increase
	Upload(Mbps)	1.92	2.21	15.10% increase
2.4GHz to 5 GHz For mitigation the interference	Signal-to-Noise Ratio(dB)	-75.0	-15.0	80% reduce
	Signal Strength(dBm)	-75.0	-15.0	80% reduce
	Signal-to-NoiseRatio Average(dB)	-66.0	68.0	200% reduce
	Signal Strength Average(dBm)	-50.2	-15.4	69.32% reduce
	Ping(ms)	54.60	56.35	3.21% increase
	Download(Mbps)	1.35	4.19	210.37% increase
	Upload(Mbps)	1.92	2.15	11.98% increase

From this table we see that after mitigation, The signal strength becomes strong, download and upload speed become faster than before mitigation.

Chapter 6: Performance Analysis

In this work, we used Wi-Fi Analyzer, Wi-Fi SNR, Network manager software. At first, using Wi-Fi analyzer we found the channel graph and time graph of the signal strength. Then using Wi-Fi SNR we found the signal to noise ratio for both current time and average, link speed and signal strength. By using speed meter we found the ping value, upload speed and the download speed. We did all of this before mitigation of the interference. After mitigating the interference we did the same things and find out the same parameters. we see that after mitigation the parameters and the signal strength is greater than before the mitigation. The graphs and the results are shown in the table below:

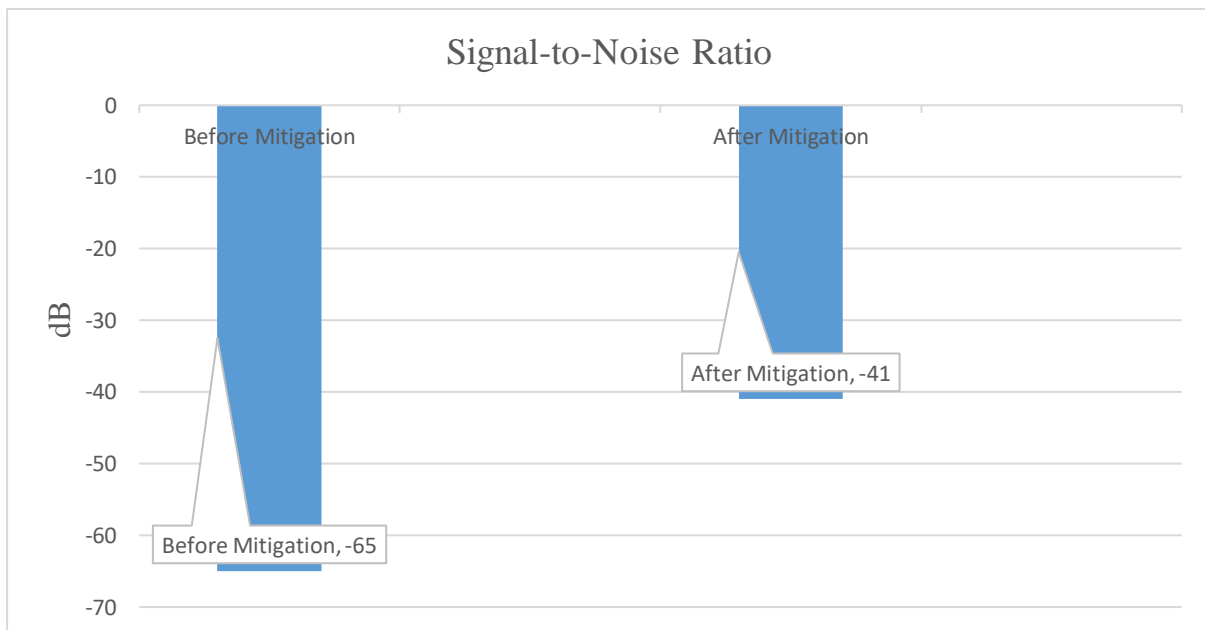

Figure 6.1: Decreased SNR for avoiding interference

In figure 6.1, we see that signal to noise reduce 36%. In these Figure 6.1, 6.2, 6.3 & 6.4 we see that, when we avoid the interference the value of the SNR becomes low, signal strength becomes high and upload & download speed is increased. When the value of the SNR becomes low, signal strength becomes high and upload & download speed is increased this time we can say that the interference is mitigated.

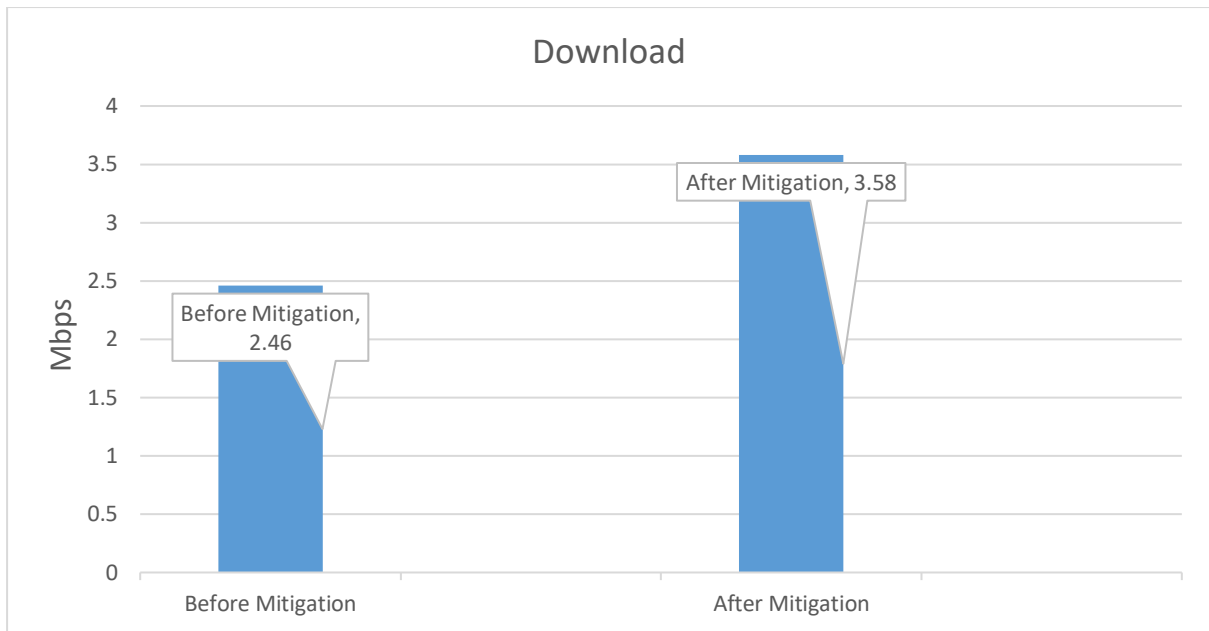

Figure 6.2: Increased download speed for avoiding interference

In figure 6.2, we see that 45.53% download speed increase and in figure 6.3, we see that 0.82% update speed increase.

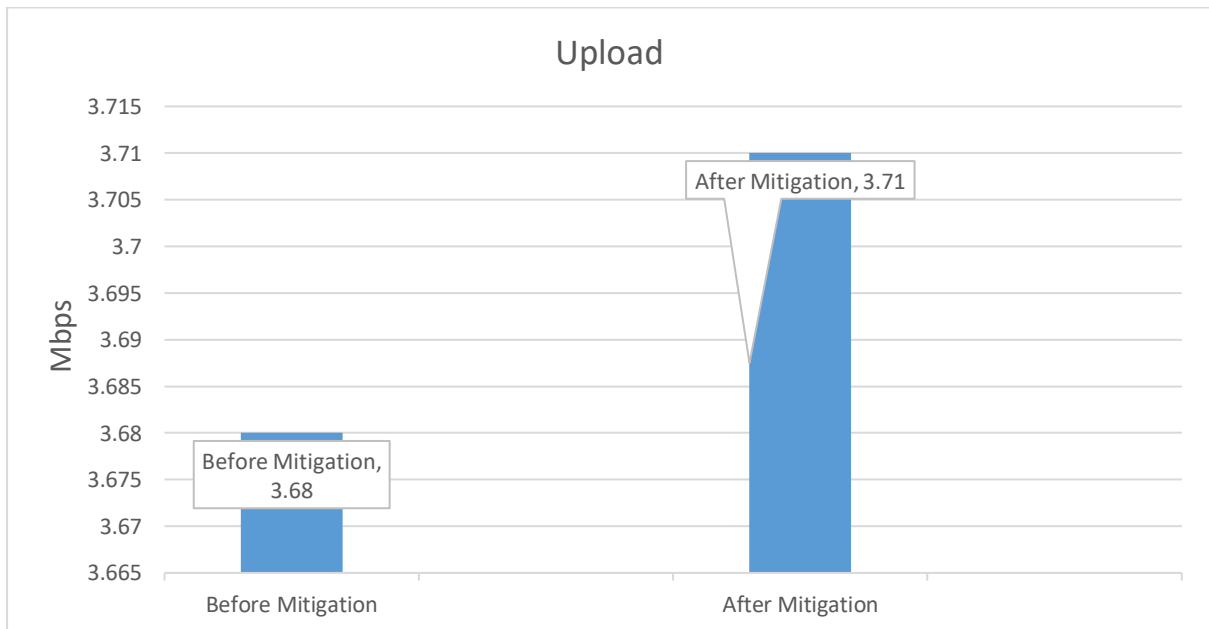

Figure 6.3: Increased update speed for avoiding interference

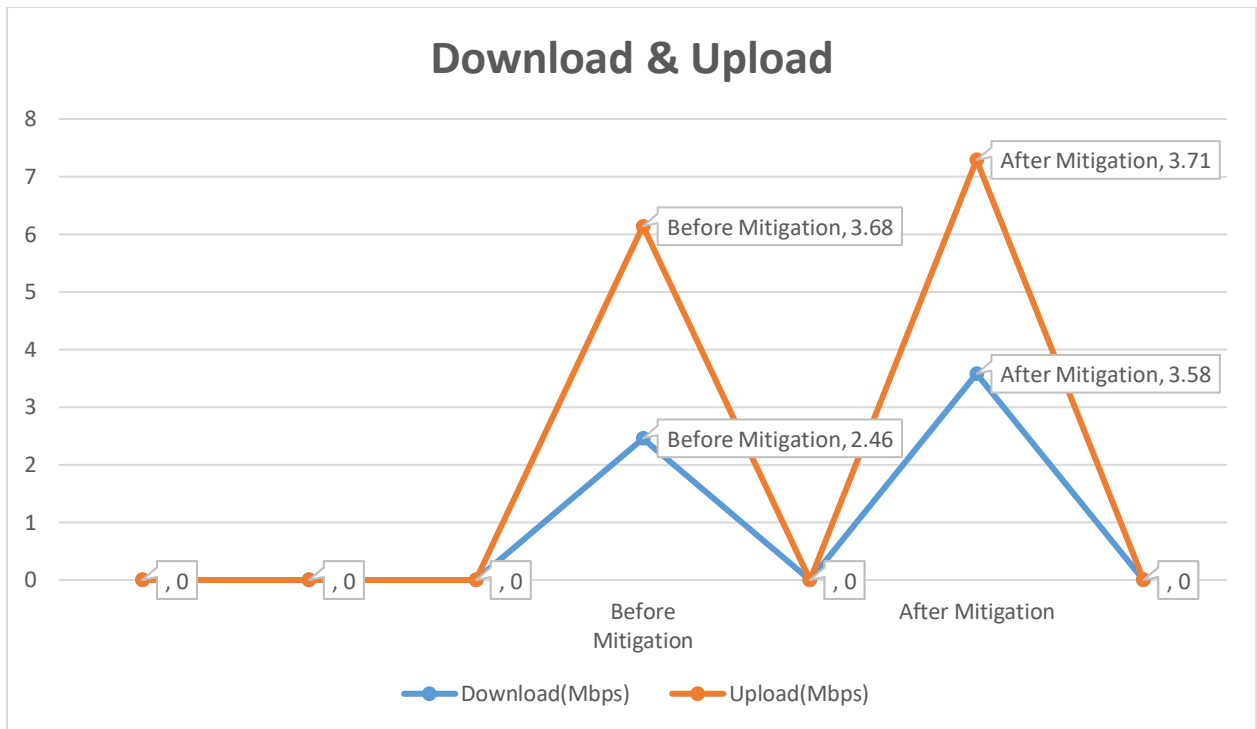

Figure 6.4: Increased download & update speed for avoiding interference

For avoiding overlapping we change the channel and we get a positive result for this.

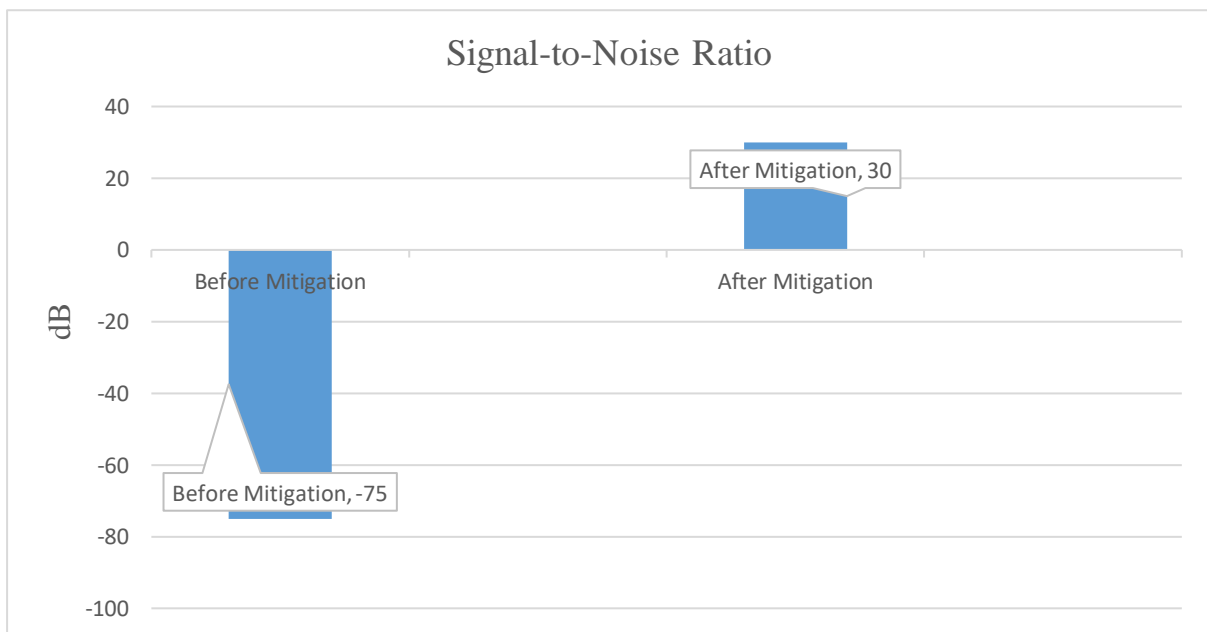

Figure 6.5: Decreased SNR for SNR for Channel Changing

In figure 6.5, we see that signal to noise reduce 140%. In these Figure 6.5, 6.6, 6.7 & 6.8 we see that, when we Changing the Channel the value of the SNR becomes low, signal strength

becomes high and upload & download speed is increased. When the value of the SNR becomes low, signal strength becomes high and upload & download speed is increased this time we can say that the interference is mitigated.

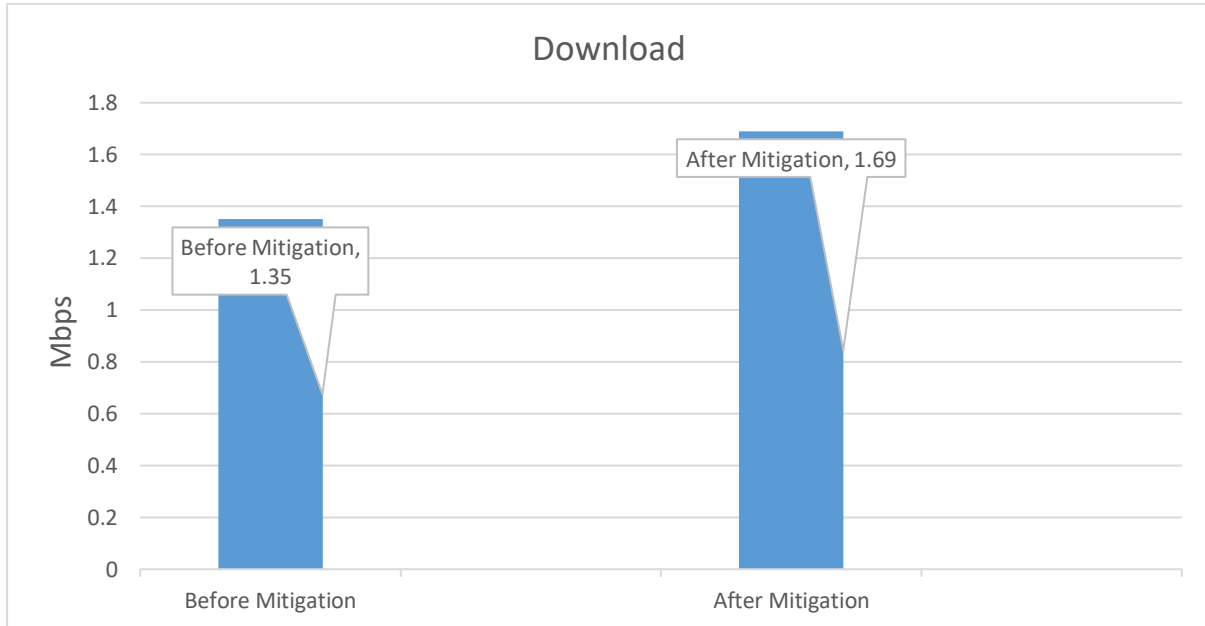

Figure 6.6: Increased download speed for Channel Changing

In figure 6.6, we see that 25.19% download speed increase and in figure 6.7, we see that 15.10% update speed increase.

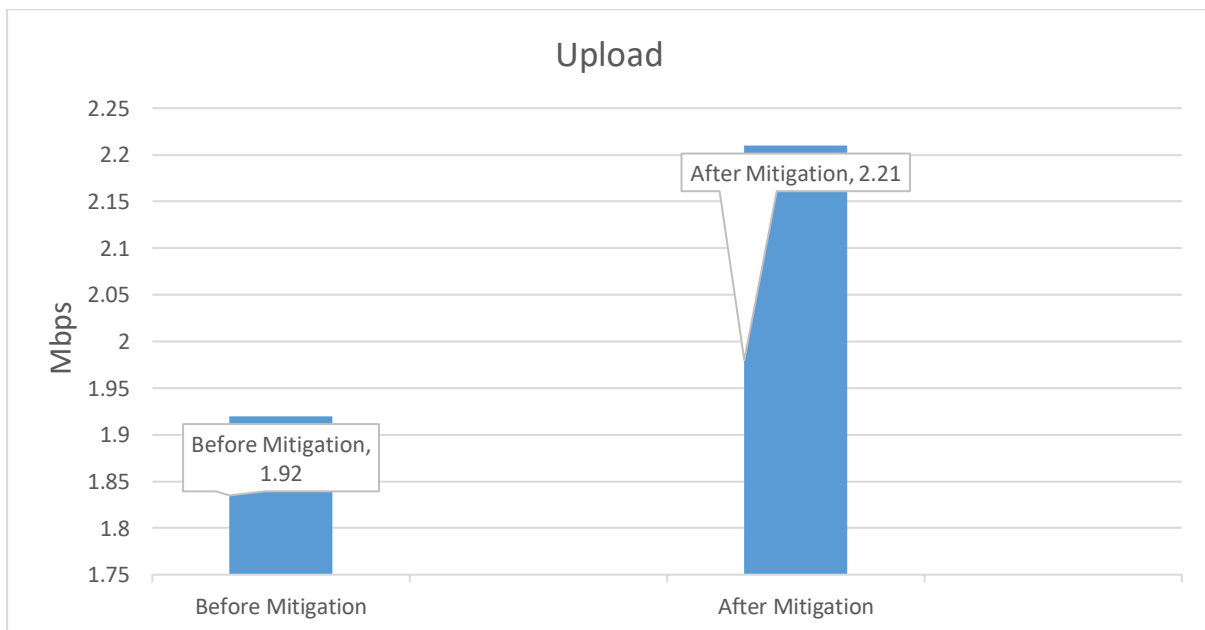

Figure 6.7: Increased update speed for Channel Changing

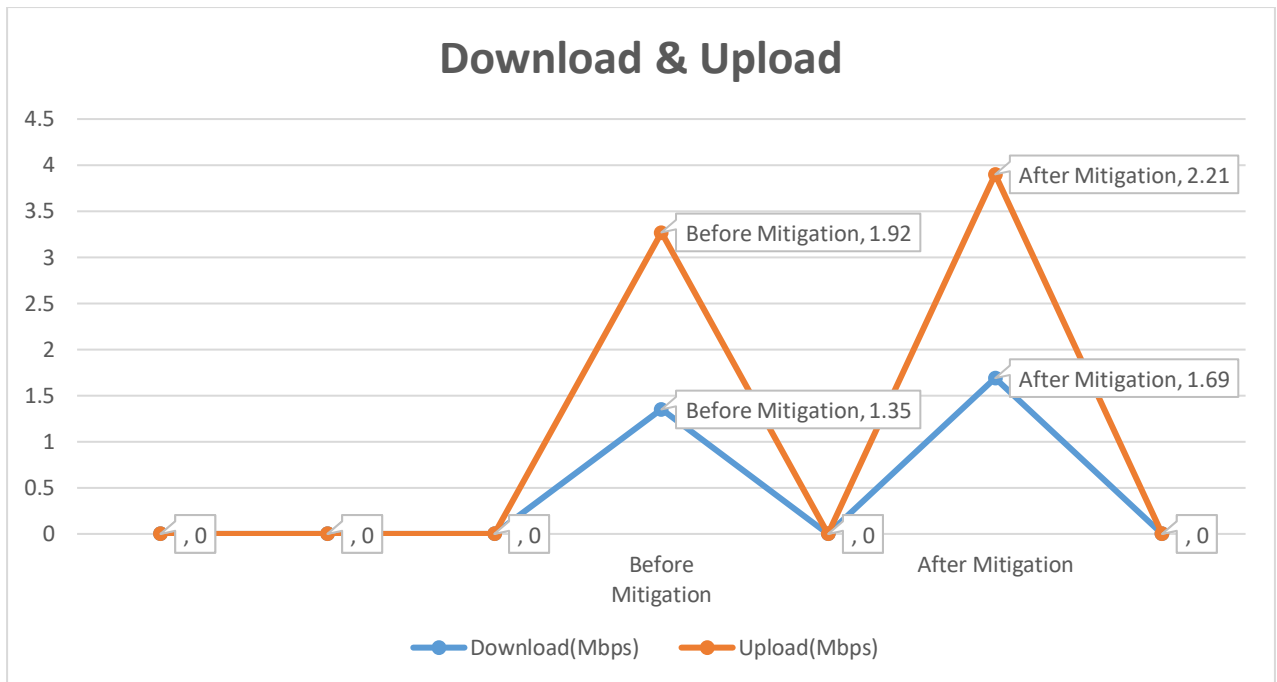

Figure 6.8 : Increased download & update speed for Channel Changing

When multiple 2.4GHz frequency bands are used together then interference occurs. To mitigate interference we use 5GHz frequency band together with 2.4GHz frequency band.

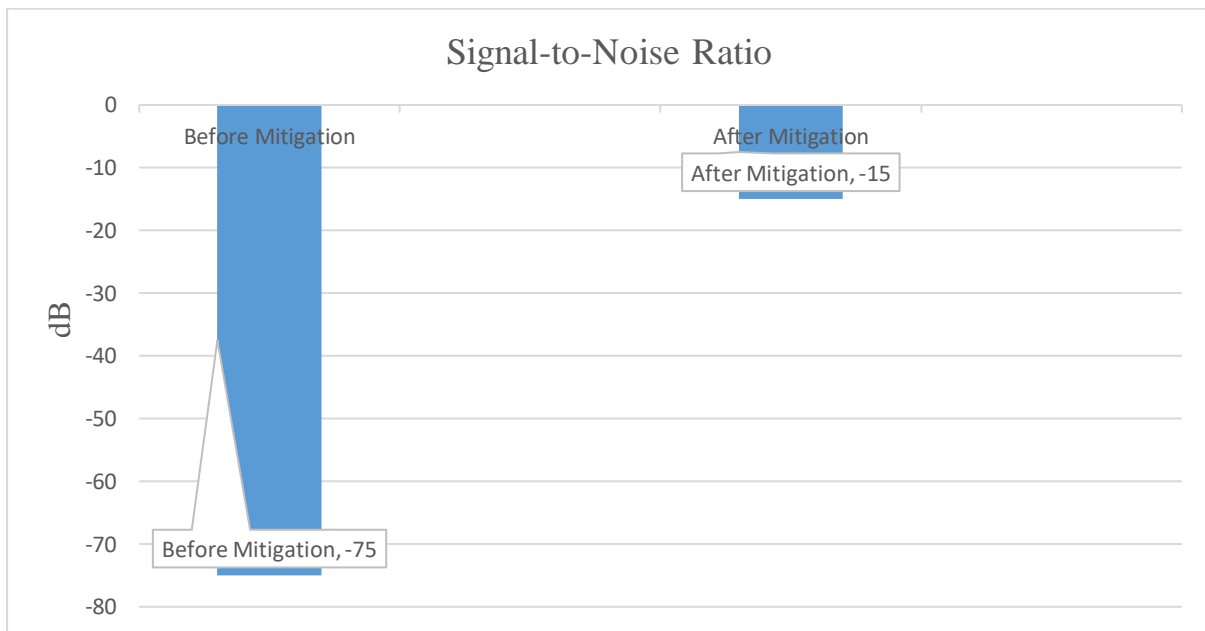

Figure 6.9: Decreased SNR for SNR for Frequency Changing

In figure 6.9, we see that signal to noise reduce 80%. In these Figure 6.9, 6.10, 6.11 & 6.12 we see that, when we used the 5GHz frequency band the value of the SNR becomes low, signal

strength becomes high and upload & download speed is increased. When the value of the SNR becomes low, signal strength becomes high and upload & download speed is increased. This time we can say that the interference is mitigated.

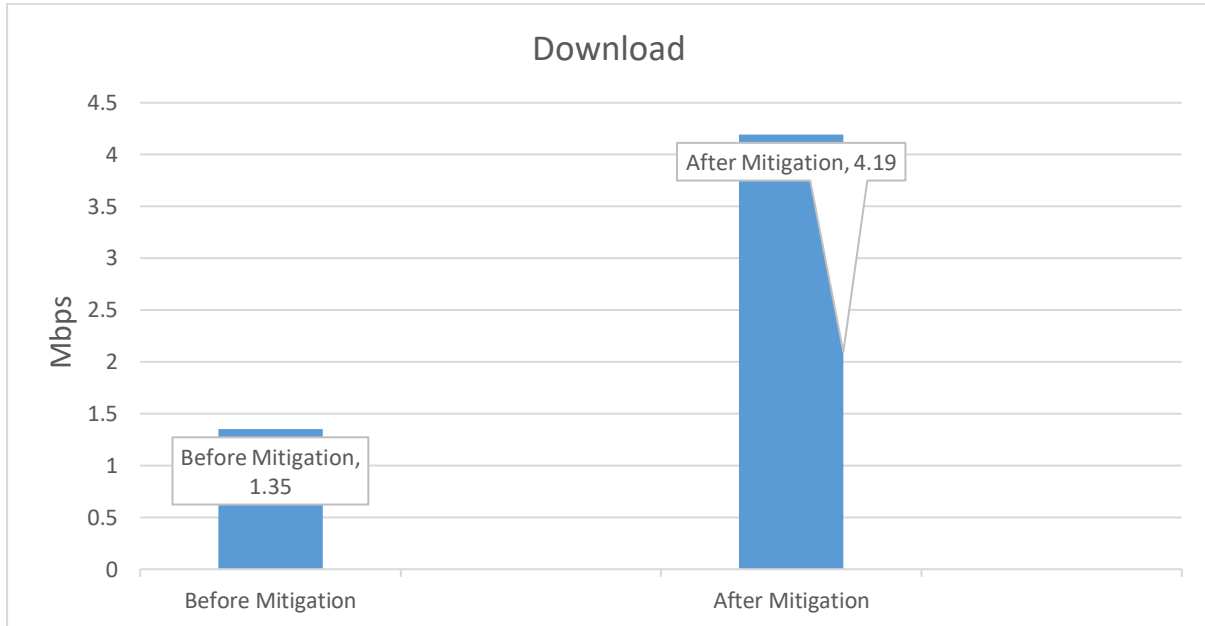

Figure 6.10: Increased download speed for Frequency Changing

In figure 6.10, we see that 210.37% download speed increase and in figure 6.11, we see that 11.98% update speed increase.

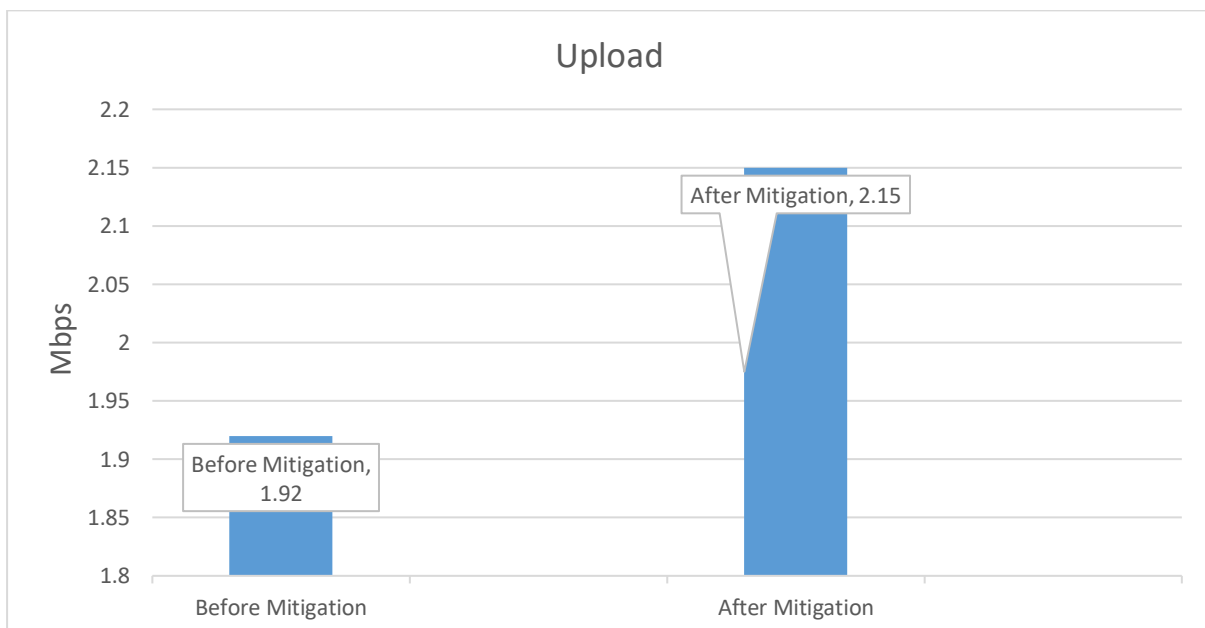

Figure 6.11: Increased update speed for Frequency Changing

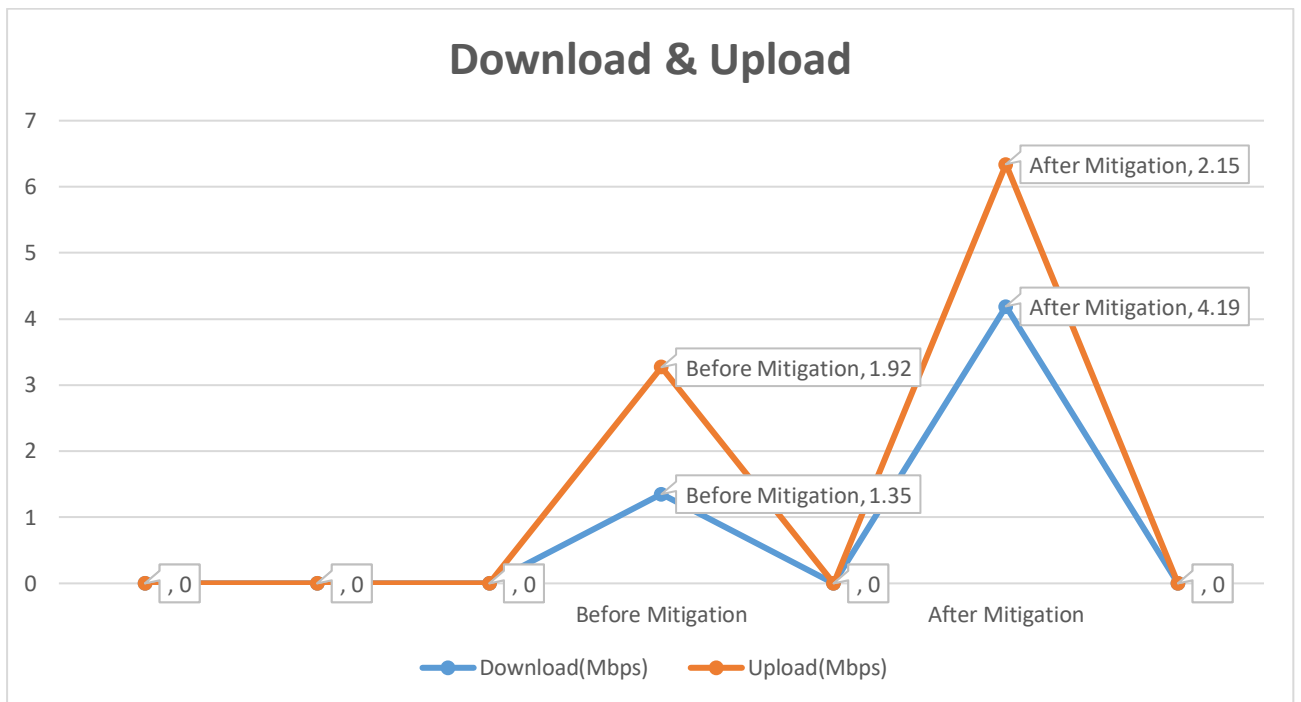

Figure 6.12: Increased download & update speed for Frequency Changing

This speed test figure 6.12 refers that, Before interference mitigation, the download & upload speed was 1.35 and 1.92 Mbps. And after interference mitigation, the present download & upload speed is 4.19 & 2.15. So we can say that here interference has been mitigated.

Chapter: 7

CONCLUSION

This project refers to the theoretical analysis and major trials to recognize the issues that can cause interference on the actions of different wireless networks. The proposed interference detection and mitigation strategies consist of two aspects: strategies for static interference and strategies for dynamic interference. The aim is to boost the operational skill of different wireless networks environment under the interference.

This project targeted the most prevalent interferences experienced by various wireless networks operators. The results are nowhere near to a single “save the world” solution. Instead, a practical measurements platform – the RF emulation testbed – was created, measurement methods and tools were developed and used for measuring the performance of several 802.11 devices. Also, several viable ideas for future research were proposed. The unlicensed 60 GHz frequency band has great potential for wireless applications. However, due to the unlicensed nature of the band, wireless networks operating in the 60 GHz band are likely to suffer from interference. In order to guarantee the QoS of wireless video applications, the wireless devices operating in the unlicensed 60 GHz band will need PHY or MAC layer IM techniques, especially for a dense enterprise environment. Depending on the required performance and the complexity of coordination among the interfering networks, IM techniques should be carefully designed for wireless networks operating in the 60 GHz band.

Over and done with the design and implementation of interference mitigation policies, including physical and frequency detachment among the target scheme & interferers, engaging active routing protocols and permitting energetic frequency swiftness etc. The probability to overwhelmed interference below certain environments has been validated. The analysis and methods obtainable in this proposition are primarily based on case study and theoretical analysis.

We hope that this project will help for implementing the testbed would help the mankind's progress at least a tiny little bit.

References

- [1] Mike Harwood, CompTIA Network- N10-004 Exam Cram, 3rd Edition, June 9, 2009
- [2] (10:47 AM, 01 November 2018) added on: <https://support.apple.com/en-us/HT201542>
- [3] Jean-Paul M.G. Linnartz and Frank Kamperman, 1993, 1995
- [4] Jean-Paul M.G. Linnartz (Editor-in-Chief), 1996-2010
- [5] J. A. Fleming, The Principles of Electric Wave Telegraphy and Telephony, London, Longmans, Green & Co., 1919, p. 364
- [6] IEEE Std 521-2002 Standard Letter Designations for Radar-Frequency Bands Archived 2013-12-21 at the Wayback Machine., Institute of Electrical and Electronics Engineers, 2002. (Convenience copy at National Academies Press.)
- [7] "Milestones in the Bluetooth advance". Ericsson Technology Licensing. 22 March 2004. Archived from the original on 20 June 2004
- [8] N. Abramson (1970). "The ALOHA System - Another Alternative for Computer Communications" (PDF). Proc. 1970 Fall Joint Computer Conference. AFIPS Press
- [9] N. Abramson (December 2009). "The ALOHAnet – Surfing for Wire1ess Data" (PDF). IEEE Communications Magazine. 47 (12): 21–25
- [10] Overview of Wire1ess Communications". cambridge.org. Retrieved 8 February 2008.
- [11] Lekomtcev, Demain; Maršálek, Roman (June 2012). "Comparison of 802.11af and 802.22 standards – physical layer and cognitive functionality". elektrovrevue. Retrieved 2013-12-29.
- [12] Callaway, E., Gorday, P., Hester, L., Gutierrez, J.A., Naeve, M., Heile, B. & Bahl, V., "Home Networking with IEEE 802.15.4: A Developing Standard for Low-Rate Wire1ess Personal Area Network", IEEE Communications Magazine, Vol. 40, No. 8, pp.70-77, 2002.
- [13] Latre, B., Mil, P.D., Moerman, I., Dhoedt, B., Demeester, P., & Dierdonck, N.V., "Throughput and Delay Analysis of Unslotted IEEE 802.15.4", Journal of Networks, Vol. 1, No. 1, pp. 20-28, 2006
- [14] Petrova, M., Riihijarvi, J., Mahonen, P., & Labella, S., "Performance Study of IEEE 802.15.4 Using Measurements and Simulations", Wire1ess Communications and Networking Conference (WCNC), pp. 487–492, 2006.
- [15] Petrova, M., Riihijarvi, J., Mahonen, P., & Labella, S., "Performance Study of IEEE 802.15.4 Using Measurements and Simulations", Wire1ess Communications and Networking Conference (WCNC), pp. 487–492, 2006.
- [16] Howitt, I., & Gutierrez, J.A., "IEEE 802.15.4 Low Rate-Wire1ess Personal Network

Coexistence Issues”, IEEE Wireless Communications and Networking Conference (WCNC), Vol 4, pp. 1481–1486, 2003.

[17] (12:47 AM, 16 November 2018) added on :<https://www.netspotapp.com>

[18] Netspot and its function. (10:47 AM, 16 November 2018) added on:

<https://www.revolvy.com/page/NetSpot>.

[19] Zhou, G., He, T., Stankovic, J.A., & Abdelzaher, T., “RID: Radio Interference Detection In Wireless Sensor Networks”, Proceedings of 24th Annual Joint Conference of the IEEE Computer and Communications Societies, Vol. 2, pp. 891 – 901, 2005.

[20] Molisch, A.F., “Wireless Communications”, John Wiley & Sons Ltd, 2005

[21] JN5139 Data Sheet,2009.http://www.jennic.com/download_file.php?supportFile=JNDSJN5139MO-lv5.pdf

[22]Frequency Hopping Spread Spectrum (FHSS)

(12:47 PM, 26 November 2018) added on: <https://hasanengineer.blogspot.com/2013/07/fhss-implemented-in-matlab.html?fbclid>.

[23](01:47 AM, 05 December 2018) added

on :<http://hasanengineer.blogspot.com/2013/07/fhss-implemented-in-matlab.html>.

[24] (01:47 AM, 05 December 2018) added on:

<http://www.revolutionwifi.net/revolutionwifi/2013/03/80211ac-channelplanning.html>

[25](12:47AM, 06 December 2018)added on:

<https://etud.insatoulouse.fr/~rprevost/IEEE802.11n/Physical%20Layer%20Improvements.html>

[26] Chaves, L.J., Madeira, E.R.M. & Garcia, I.C. J Braz Comput Soc (2013) 19: 493.

<https://doi.org/10.1007/s13173-013-0113-y>

[27] Serway, Raymond; Faughn, Jerry; Vuille, Chris (2008). College Physics, 8th Ed. Cengage Learning. p. 714. ISBN 0495386936.

[28] Ellingson, Steven W. (2016). Radio Systems Engineering. Cambridge University Press. pp. 16–17. ISBN 1316785165.

[29] IEEE 802.11-1997: The WLAN standard was originally 1 Mbit/s and 2 Mbit/s, 2.4 GHz RF and infrared (IR) standard (1997)

[30] "IEEE-SA Standards Board Operations Manual". IEEE-SA. Archived from the original On 2015-09-06. Retrieved 2015-09-13.

[31] Hecht, Eugene. 2001. Optics, 4th ed. Pearson Education. ISBN 0-8053-8566-5

[32] Tech LibraryJunos Space Network Director, Release 3.1 Network Director User Guide.

(12:47 AM, 16 December 2018) added on :

https://www.juniper.net/documentation/en_US/junos-space-apps/network-director3.1/topics/concept/wireless-interference.html.

[33] (02:47 AM, 18 December 2018) added on:

<https://www.britannica.com/topic/communication>.

[34] (08:10AM, 18 December 2018) added on : <https://www.goldtouch.com/stop-bluetooth-interference-messing-devices>.