

Faculty of Engineering  
Department of Textile Engineering

**Course Title: Industrial Attachment**  
**Course Code: TE 410**

**An Industrial Report**  
**On**  
**AMBER Denim Mills Limited (ADML)**

Submitted By

**Md. Salman Sikder**

ID: 151-23-4128

**Md. Akter Hossain**

ID: 151-23-4109

Supervised by:

**Mrs. Nawshin Farzana**

Senior Lecturer

Department Of Textile Engineering

Faculty of Engineering

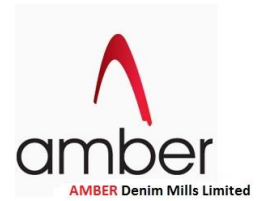
Daffodil International University

A report submitted in partial fulfillment of the requirements for the degree of  
Bachelor of Science in Textile Engineering

Advance in Wet Processing Technology

Fall-2018





# **AMBER DENIM MILLS LIMITED**

**Bangla bazar, Gazipur**

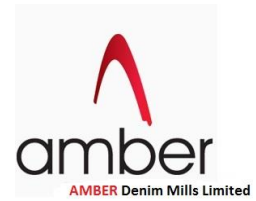


**Industrial Supervisor**

**Md. Nazmul Hasan**

**Deputy Manager (Production Planning)**

**AMBER Denim Mills Limited**



## **DECLARATION**

We hereby declare that, this industrial report has been done by us under the supervision of **Mrs. Nawshin Farzana**, senior lecturer of **Department of Textile Engineering, Daffodil International University**.

We also hereby declare that neither this report nor any part of this report has been submitted elsewhere for award of any degree.

---

**Mrs. Nawshin Farzana**

Senior Lecture

Department of Textile Engineering

Daffodil International University

---

**Md. Salman Sikder**

Student

ID: 151-23-4128

Department of Textile Engineering

Daffodil International University


---

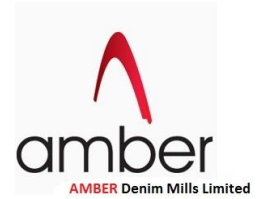
**Md. Akter Hossain**

Student

ID: 151-23-4109

Department of Textile Engineering

Daffodil International University 



## Letter of Approval

This Industrial report on ‘**AMBER Denim Mills Limited (ADML)**’ is prepared by Md. Salman Sikder (ID: 151-23-4128), and Md. Akter Hossain (ID: 151-23-4109). This report is submitted in Partial Fulfillment of the Requirement for the Degree of **BACHELOR OF SCIENCE IN TEXTILE ENGINEERING**. The whole report of internship has completed under my supervision. During the research period I have found them sincere, hardworking, punctual and enthusiastic.

**Ms. Nawshin Farzana**

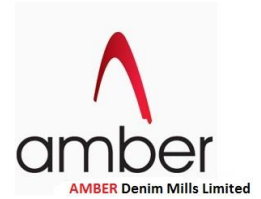
LECTURER

DEPARTMENT OF TEXTILE ENGINEERING

FACULTY OF ENGINEERING

DAFFODIL INTERNATIONAL UNIVERSITY

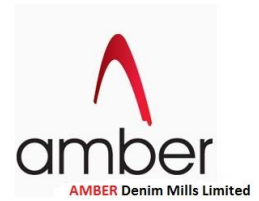




28

**“WE HAVE DEDICATED THIS REPORT  
TO  
OUR PARENTS  
WHOM HAVE SUPPORTED US IN EVERY SPHERE OF LIFE & HELP US TO  
REACH THIS LEVEL”**

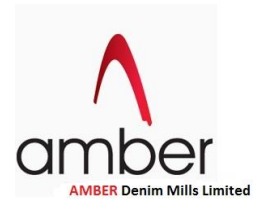




## Contents

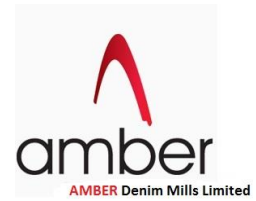
Acknowledgement .....	15
Introduction.....	17
Company Profile .....	19
1.1. PARTEX HOLDINGS:.....	19
1.2 Enterprises of Partex Holdings: .....	20
1.2.1 Textile .....	20
1.2.2 Plastics & Board .....	20
1.2.3 Food & Beverages.....	21
1.3 Enterprises of Amber Group:.....	22
1.4 Factory Location Map:.....	24
1.5 Working-Time Schedule of the Factory.....	28
1.6 Types of Machines Used in Amber Denim Mills Ltd.:.....	29
Denim & Yarn.....	31
2.1 What is Textile? .....	31
2.2 What Is Denim Fabric? .....	31
2.2.1 End Uses of denim Fabric.....	32
2.3 Production Process Flow Chart of Denim Production .....	32
2.4 Yarn Quality: .....	33
2.5 Elastic Denim Yarns: .....	34
2.6 Types of yarn used: .....	34
2.7 Yarn count used: .....	34
2.8 Suppliers of Yarn: .....	34
Ball Warping.....	36
3.1 About Warping: .....	36
3.2 Importance of Warping: .....	36
3.3 Types of Warping: .....	36
3.3.1 Direct Warping: .....	36





3.3.2 Sectional Warping:.....	36
3.4 Difference between Direct & Indirect Warping:.....	37
3.5 Ball Warping process:.....	37
3.6 Warping section in Amber Denim Mills Ltd. (ADML):.....	37
3.7 Specification of Ball Warping Machine: .....	38
3.8 Machine Main Parts: .....	39
3.9 Description of Different Parts of Machine:.....	40
3.9.1 Creel:.....	40
3.9.1.1 Some parts of Creel Zone: .....	41
3.9.2 Reed Zone: .....	41
3.9.3 Count Meter: .....	41
3.9.4 Guide Zone: .....	42
3.9.5 Eye Pot: .....	42
3.9.6 Trumpet:.....	42
3.9.7 Headstock:.....	42
3.9.8 Control Panel: .....	42
3.10 Tensions in Ball Warping Machine: .....	42
3.11 Humidification: .....	43
3.12 Process flow Chart of Ball Warping: .....	44
3.13 Process Description:.....	44
3.14 Troubleshooting: .....	45
3.15 Calculation: .....	45
Denim Dyeing.....	47
4.1 About Dyeing:.....	47
4.2 Objective of Textile Dyeing:.....	47
4.3 Denim Dyeing:.....	47
4.4 Process of denim dyeing: .....	48
4.5 Dyes use for Denim dyeing:.....	48
4.5.1 Vat Dyes: .....	48
4.5.1.1 Dyeing with vat dyes: .....	49

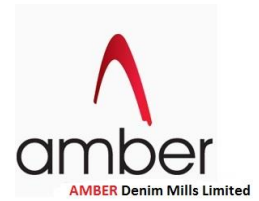




4.5.1.2 Dyeing With Sulphur Dyes: .....	49
4.6 Denim Dyeing Process:.....	50
4.6.1 Rope Dyeing: .....	50
4.6.2 Slasher Dyeing: .....	51
4.7 Difference between Slasher Dyeing & Rope Dyeing: .....	51
4.8 Dyeing Section in Amber Denim Mills Limited (ADML): .....	52
4.9 Machine Specification: .....	52
4.10 Process sequence in Indigo rope dyeing: .....	53
4.11 Dyeing machine main Parts of AMBER denim Mills Limited:.....	54
4.11.1 Creel Zone:.....	54
4.11.2 Pre Wetting: .....	55
4.11.3 Pre Wash (Cold Wash/Hot wash Box):.....	56
4.11.4 Dye Box: .....	56
4.11.5 Post Wash (Cold wash/Hot wash/rinse/fixation): .....	57
4.11.6 Softening Box: .....	58
4.11.7 Drying & Can:.....	58
4.12 Indigo Dyeing process control .....	58
4.12.1 Concentration of Hydrosulphite.....	58
4.12.2 Dye concentration in Dye bath.....	58
4.12.3 Influence of P <sup>H</sup> in shade variation:.....	58
4.12.4 Dipping Time .....	58
4.12.5 Airing Time.....	59
4.12.6 Drying .....	59
4.13 Types of Denim Dyeing:.....	59
4.14 Dyeing Recipe:.....	59
4.15 Chemicals Used for dyeing in Amber Denim Mills Limited: .....	72
4.16 Equipments/Machines used in Dyeing Laboratory: .....	72
4.17 Troubleshooting: .....	73
4.18 Calculation: .....	74
Long Chain Beamer (LCB).....	76

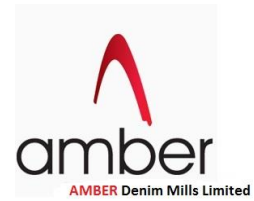




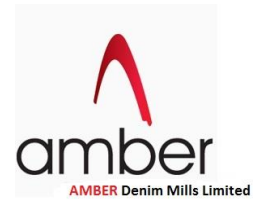


5.1 About Long Chain Beamer Unit: .....	76
5.2 Long chain beamer section in AMBER Denim Mills Limited: .....	76
5.3 Machine Specification: .....	77
5.4 Process Flow Chart of Long Chain Beamer: .....	78
5.5 MAIN PARTS OF THE MACHINE WITH DESCRIPTION:.....	79
5.5.1 Accumulator:.....	79
5.5.2 Tension Stand: .....	79
5.5.3 Beater Bar and Comb:.....	80
5.5.4 Stop Motions:.....	80
5.6 Process Flow Chart of Long Chain Beamer (LCB):.....	81
5.7 Controlling Parts & Parameters: .....	82
5.8 Troubleshooting: .....	82
Sizing Process .....	84
6.1 SIZING PROCESS: .....	84
6.2 Objects of Sizing:.....	84
6.3 Changes in Yarn due to Sizing:.....	84
6.4 MACHINE SPECIFICATION: .....	85
6.5 PROCESS FLOWCHART .....	86
6.6 MACHINE PARTS & DESCRIPTION: .....	88
6.7 USED CHEMICAL FOR SIZING: .....	90
6.8 FUNCTION OF THE CHEMICAL:.....	91
6.8.1 Starch: .....	91
6.8.2 Binder:.....	92
6.8.3 Softener:.....	92
6.8.4 Anti-septic agent or Anti mildew agent: .....	92
6.8.5 Weighting agent:.....	92
6.8.6 Antifoaming Agents:.....	92
6.9 Recipe & Testing: .....	93
6.9.1 RECIPE for sizing: .....	93
6.9.2 TESTING:.....	93



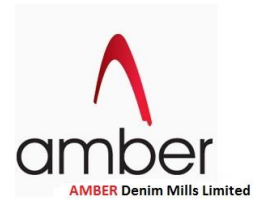


6.10 Controlling Parameters of Sizing:.....	94
Weaving .....	96
7.1 Weaving defination: .....	96
7.2 DENIM WEAVING: .....	96
7.3 Basic Weave Designs:.....	96
7.3.1 Plain weave: .....	96
7.3.2 Twill Weave:.....	97
7.4 Classification of Modern Weaving Machines:.....	98
7.4.1 Air-Jet loom: .....	98
7.4.1.1 Advantages of Air Jet Loom: .....	98
7.4.2 Rapier Loom: .....	99
7.5 Basic Motions: .....	100
7.5.1 Primary Motion:.....	100
7.5.1.1 Shedding mechanism: .....	100
7.5.1.2 Picking Mechanism:.....	101
7.5.1.3 Beating up Mechanism: .....	102
7.6 Secondary Motion:.....	102
7.6.1 Take Up Motion:.....	102
7.6.2 Let Off Motion:.....	102
7.7 Tertiary Motions: .....	103
7.8 Weaving in Amber Denim Mills Limited: .....	103
7.9 Machine specification: .....	104
7.10 Process before weaving.....	105
7.10.1 Knotting machine (Warp Tying-In): .....	105
7.10.1.1 Machine parts:.....	105
7.10.1.2 Setting of Needle according to count:.....	105
7.10.2 Catch Cot Bobbin:.....	106
7.10.3 Leno Bobbin: .....	106
7.11 Process Flow Chart of Air-jet Weaving Machine:.....	106

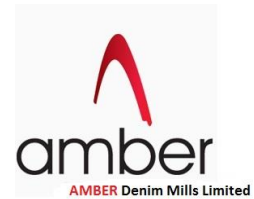


7.12 Main parts of weaving Machine: .....	108
7.12.1 Warp Parts:.....	108
7.12.2 Weft Parts: .....	110
7.13 Selvage:.....	112
7.14 Calculation: .....	113
Finishing .....	116
8.1 Finishing process: .....	116
8.2 Denim Finishing: .....	116
8.3 Objects of fabric Finishing: .....	116
8.4 Types of fabric finishing: .....	116
8.5 Finishing section of AMBER Denim Mills Limited:.....	117
8.6 Finishing Machine in ADML:.....	117
8.7 Finishing Process in Amber Denim Mills Limited: .....	118
8.8 Process sequence of different finishing process: .....	118
8.8.1 Normal finish: .....	118
8.8.2 Soft Finish.....	119
8.8.3 Flat Finish: .....	120
8.8.4 Stenter: .....	122
8.8.5 Soft finish Stenter: .....	122
8.9 Machine specification: .....	123
8.9 Sanforizing finishing machine: .....	124
8.9.1 Introduction.....	124
8.9.2 Machine main parts:.....	124
8.10 Clip Chain Mercerization/desizing machine:.....	131
8.10.1 Introduction.....	131
8.10.2 Machine parts:.....	131
8.11 Stenter machine:.....	132
8.11.1 Introduction:.....	132
8.11.2 Main parts of stenter machine: .....	133
8.11.3 Working principles of stenter machine: .....	133

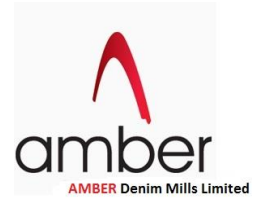




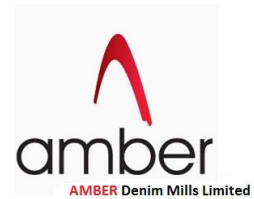
8.12 Controlling Parts & Parameters: .....	133
Inspection.....	135
9.1 About Inspection:.....	135
9.2 Inspection Process:.....	135
9.3 Four Point system: .....	135
9.4 Inspection in Amber Denim Mills Limited:.....	135
9.5 Machine Specification: .....	136
9.6 Fabrics Defect: .....	136
9.6.1 Removable Defects: .....	137
9.6.2 Non removable defects:.....	137
9.7 Major Fabric Faults:.....	137
9.8 Defects & code no of defects in ADML .....	140
Denim Washing.....	141
10.1 Denim Washing: .....	141
10.1.1 Reasons for Denim Washing: .....	141
10.1.2 Objectives of denim washing:.....	142
10.2 Types of Washing: .....	142
10.3 Denim Washing in AMBER Denim Mills Limited: .....	143
10.4 Machine Used for Denim Washing:.....	143
10.4.1 Industrial washing machine .....	143
10.4.1.1 Machine Specification: .....	144
10.4.2 Industrial Washing Machine: .....	144
10.4.3 Industrial Water extractor: .....	145
10.4.4 Industrial Dryer:.....	145
10.5 Description of Washing Types:.....	145
10.5.1 Desizing: .....	145
10.5.1.1 Objects of desizing:.....	146
10.5.2 Enzyme wash: .....	146
10.5.3 Bleach wash .....	147



10.5.4 Sand Blasting .....	147
10.5.5 Acid Wash:.....	148
10.6 Washing Chemical Used in ADML: .....	148
10.7 Washing Recipe for a leg piece: .....	150
10.7.1 Desizing recipe: .....	150
10.7.2 Enzyme Wash recipe:.....	150
10.7.3 Bleach wash: .....	151
10.7.4 Neutralization:.....	151
10.7.5 Acid wash recipe:.....	151
10.8 Washing Procedure: .....	152
10.9 Most Common Denim Washes: .....	152
Utilities.....	<b>Error! Bookmark not defined.</b>
11.1 Definition: .....	155
11.2 Utility section of AMBER Denim Mills Limited: .....	155
11.3 Water Supply: .....	155
11.4 Boiler: .....	155
11.5 Generator: .....	157
11.6 Air Compressor:.....	158
11.7 Chiller: .....	158
11.8 AC Plant:.....	159
11.8.1 Working Principle:.....	159
11.9 Effluent Treatment Plant (ETP): .....	159
11.9.1 Process of Effluent treatment plant (ETP): .....	160
Research & Development (R&D) .....	163
12.1 Research & Development (R&D) in Amber Denim Mills Limited: .....	163
12.2 Testing in R&D:.....	164
12.3 Equipments Used in R&D .....	164
Limitations of the report: .....	165
Conclusion .....	165



References:..... 166



## Acknowledgement

Firstly we would like to thank the Almighty Allah for giving us such patient to complete my internship & help me to complete this industrial attachment.

While preparing this internship paper, I have understood that there is a huge difference between industrial knowledge & book knowledge whatever we have read in our university. I would like to thank the Almighty that he gives me such understanding knowledge so that I could also well understand the industrial work.

We would like to thank **Engr. Md. Kamruzzaman**, G.M. (Plant), Amber Denim Mills Limited (ADML) to give us the opportunity of industrial Training in his Mill.

We are greatly like to thank **Md. Nazmul Hasan**, Deputy Manager (Production Planing), Amber Denim Mills Limited (ADML) to act as our industrial suvervisor & give us the proper guidance and cordial support while the period of internship. We are debt to him.

We would like to thank Engr. Mahmudul Hasan, DGM (Preparatory section), Amber Denim Mills Limited (ADML) to give us the permission on working in Preparatory section & also give proper guidance while working in preparatory section.

We would like to thank Md. Mominul Islam, Deputy Manager (Dyeing), Amber Denim Mills Limited (ADML) to give us the permission of working in Dyeing & dyeing laboratory. We have learned a lot from dyeing.

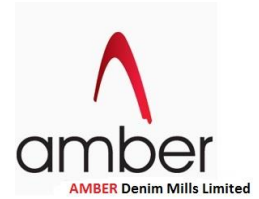
From weaving section, we would like to thank Mr. Hamim Khair, Deputy Manager (Weaving), Amber Denim Mills Limited (ADML) for his support.

We would like to thank Mr. Milton Das Roy (R&D), Mr Abid (Dyeing), Mr. Tuhin (Weaving), for share their learning & working experiences in industry & motivate us.

We would like to thank to the management of **Amber Denim Mills Limited (ADML)** for giving me the opportunity to undergo Industrial Training there.

We would like to thank all the Officer's, Staffs & workers of Amber Denim Mills Limited. They have helped us in every sphere in of our training period.

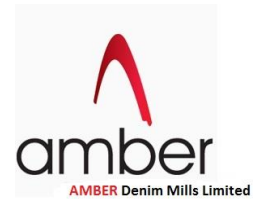
We would like to thank our Supervisor, Nawshin Farzana, Senior Lecturer, Department of Textile Engineering, Daffodil International University for her proper support & guidance so that we can do industrial work properly.



Lastly we would like to thank **Prof. Md. Mahbubul Haque**, Head of the Textile Engineering department, Daffodil International University for his application towards Amber Denim Mills Limited (ADML) to give us the opportunity to complete & work our industrial training there.

So it can be said that without help of so many people in different section it would not be possible for us to prepare this internship report. So we would like to give proper thanks to all who directly or indirectly contributed and inspired us time to time in preparing the report.





## Introduction

Theoretical life provides us what we have learned. But Practical life teaches us how the theory is solved. It is always easy to a man understanding something by showing practically. As we are studying in a technical line, it is always important for us to gather the practical knowledge.

In our study life the only biggest chance for us to combine the theoretical knowledge with the Practical knowledge is the “Industrial Attachment” that comes only once in the education life when completing under graduate education.

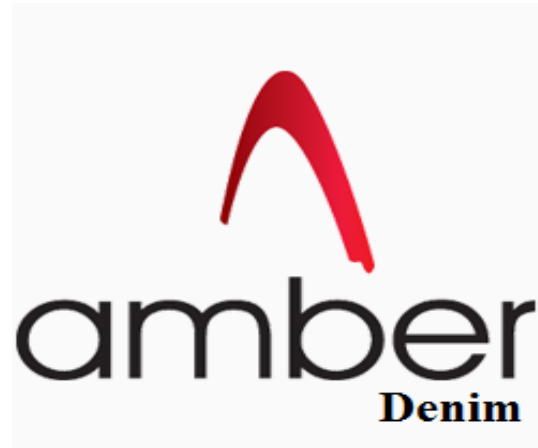
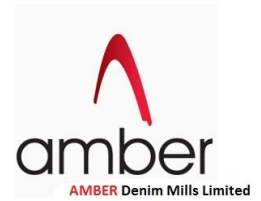
The industrial attachment is referred to gain practical skills & knowledge’s to students and for them to appreciate the work in the industry before being fully employed after completing their studies. By going through this phase the industrial attachment period equips the student with realistic practical skills. This means in the field there are quick to exert this expertise on any task. Lesser skills training time is needed to equip such persons. This means graduate students are well prepared for the industry when they finish their studies.

So industrial attachment is the process where a student can update his theoretical knowledge with practical knowledge which increased his ability of work, skills, performance and attitude in all workplace.

So we can easily understand the importance of Industrial Attachment. The knowledge we gathered from the industrial training reflects in the report of industrial attachment book.

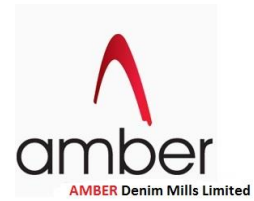
It provides sufficient knowledge about industrial management, productivity evaluation, work study & efficiency, production planning and control, inventory management, utility, maintenance etc. Industrial attachment makes us reliable to be accustomed with the industrial atmosphere condition and also inspiration to take self-responsibility & make self-ability to work any place in life.

We have tried our best to make this industrial attachment book. During training, we have tried to gather a lot of necessary information from different section which is valuable for us. We would hope that will help a lot in our future life.



# Chapter One

# Company Profile



## Company Profile

### **1.1. PARTEX HOLDINGS:**

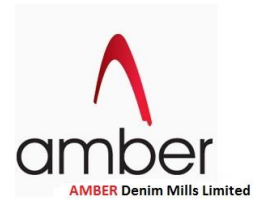
**Partex Holdings** is a conglomerate comprising 20 companies across diverse industries. Adjusting to the ever changing global environment, it is an exodus from patrimonial management system to professional management system, using the Partex name as a springboard that has been respected in Bangladesh for 50 years for its adherence to strong values and business ethics.

Founded by **Mr. M.A. Hashem** in 1959, the mother ship PARTEX'S early years were inspired by the spirit of nationalism. Initially a major importer of consumer products and materials, fast transition to import substitution made it possible to become pioneer in several industries of national importance in newly independent Bangladesh. In more recent times, its pioneering spirit has been showcased by PARTEX HOLDINGS, with direction from the competent next family generation comprising Mr. Aziz Al-Kaiser, Mr. Aziz Al-Mahmood, Mr. Aziz Al-Masud, Mr. Showkat Aziz Russell & Mr. Rubel Aziz.

PARTEX HOLDINGS companies now operate in business sectors like communications and information technology, energy, materials, services and consumer products. The major Partex Holdings companies are Partex Plastics, Partex Denim, Partex Beverage, Amber Pulp, Amber Cotton, Partex Rotor Spinning Mills, Partex Spinning Mills, Partex Sugar Mills Ltd., Partex Paper Mills Ltd.

In a short span of time, PARTEX HOLDINGS' concerns have shown incomparable success. Partex Beverage Ltd. has positioned at the 2nd position in the local beverage market being the sole official bottler of Royal Crown Cola Co. For international demand, Partex Denim has been supplying over 3 million yards per month with minimum lead time, superior quality at the best price, color consistency and meticulous packaging. Amber IT services are to cover all 64 districts by end of 2010 through Dhaka com, which is also connected to all major Telecom Carriers in the country.

Going forward, Partex Holdings is focusing on new technologies and innovation to drive its business in Bangladesh and internationally.



---

**Mr. M.A. Hasem**  
Chairman, Partex Group

## **1.2 Enterprises of Partex Holdings:**

### **1.2.1 Textile**

- Partex Rotor Spinning Mills Limited
- Partex Spinning Mills Limited
- Partex Rotor Mills Limited
- Amber Cotton Mills Limited
- Partex Denim Limited
- Amber Denim Mills Limited

### **1.2.2 Plastics & Board**

- uPVC Pipes & Fittings
- PP-R Pipes & Fittings
- Plastic Furniture
- Partex Board

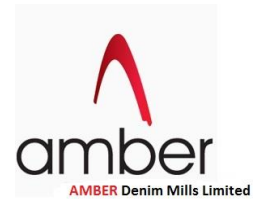


### 1.2.3 Food & Beverages

- Partex Beverages

### 1.2.4 Paper

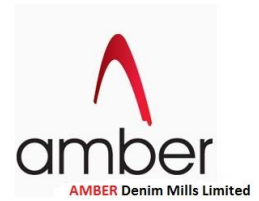
- Amber Paper & Pulp Mills Limited



## **Md. Showkat Aziz Russell**

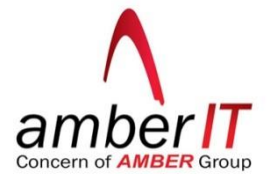
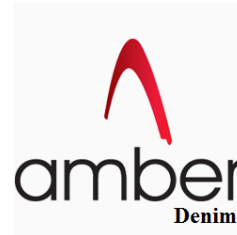
### **Chairman of Amber Group**

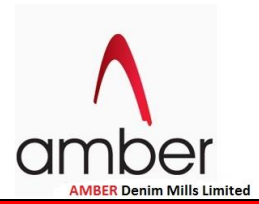
Amber Group was established in 1996 and began its journey with Amber Cotton Mills Limited. The group flourished with its gradual demand in the market. Apart from cotton, other successful areas where the group operates include denim, board and doors, Internet gateway, radio, lifestyle shopping outlet and leisure resort etc. The process of establishing a television channel is ongoing. Backed by a high density of advanced technology and sophisticated manufacturing facilities, Amber group is being managed by highly qualified technical and management professionals. The excellence of the technology and blooming genius of its personnel are the strength of the organization. Amber Group with its various interests is rolling ahead with drive and determination to be the best in all the areas it operates.



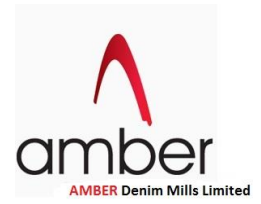
### 1.3 Enterprises of Amber Group:

- ★ Amber Cotton Mills Limited
- ★ Amber Denim Limited
- ★ Amber Denim Mills Limited
- ★ Amber IT
- ★ Amber Lifestyle
- ★ Partex Spinning Mills Limited
- ★ Partex Rotor Spinning Mills Limited
- ★ Amber Board Limited
- ★ Bhawal Resort & Spa Hotel



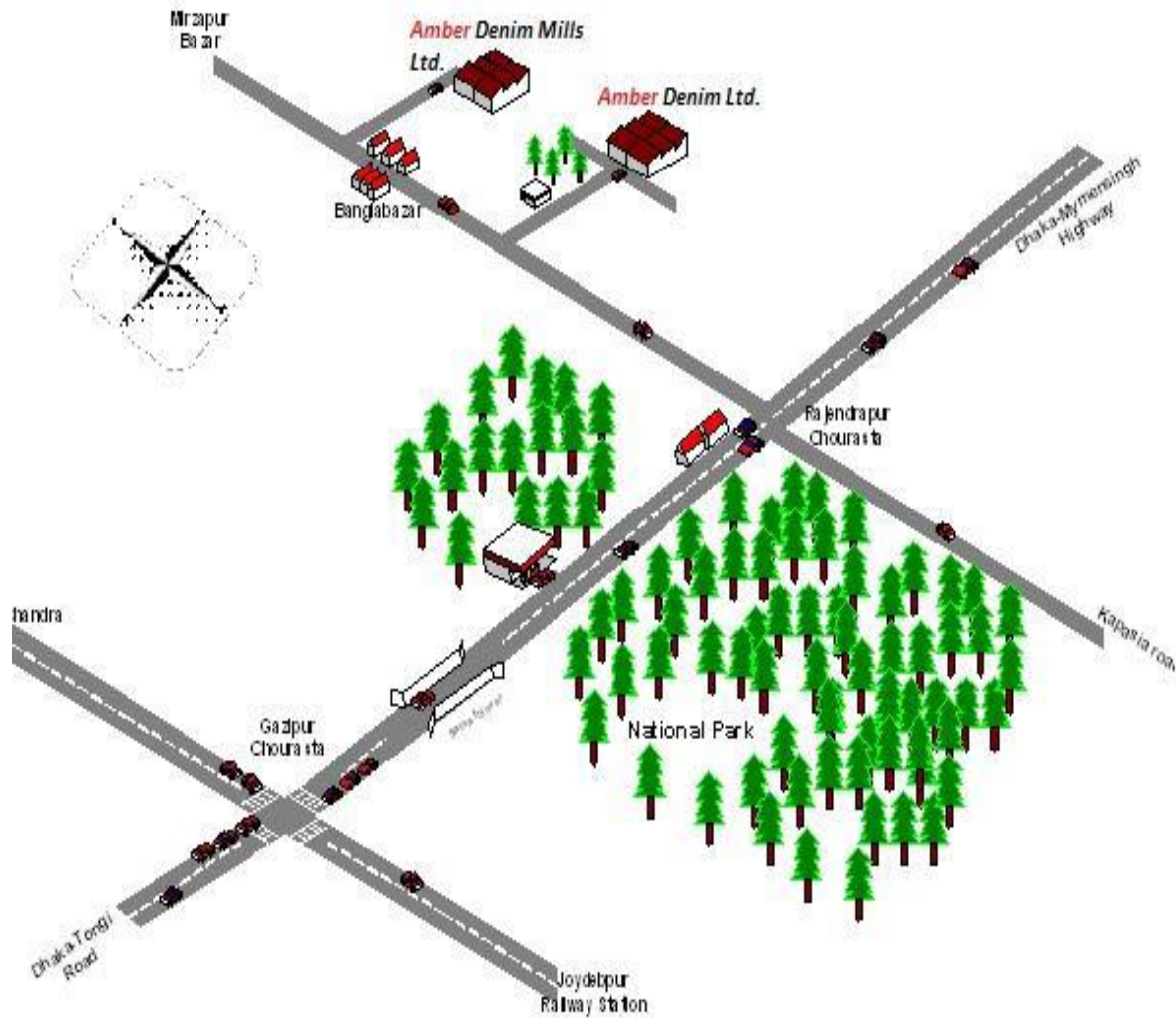


Company Name	Amber Denim Mills Limited
Owner	Mr. M.A. Hasem
Managing Director	Mr. Showkat Aziz Russell
Factory Location	Jangaliapara (Banglabazar), Mirzapur, Joydebpur, Gazipur
Corporate Office	House: 02, Road: 09, Block: G, Banani, Dhaka
Type of Factory	Fabric Manufacturing
Product	Denim Fabric
Total Area	323000 sft
Production Area	270000 sft
Structure	Steel structure surrounded by brick wall

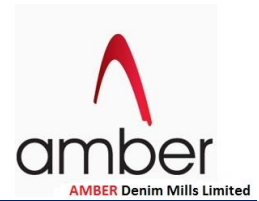


### 1.4 Factory Location Map:

## Factory Location Map





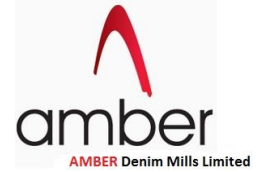


## Amber Denim Mills Ltd.



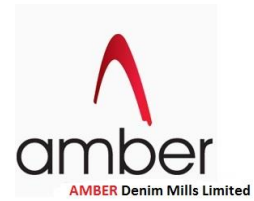
**Amber Denim Mills Ltd.** is one of the major concerns of Amber Group. It is a premium denim fabric producing company. It has started its journey in 2012 with the best and latest machinery available in the world. The current capacity is two million yards of finished fabric per month.



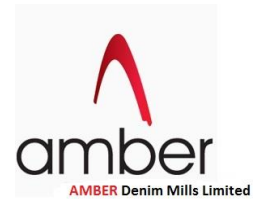


- ADML has world's best Morrison Ball warping machine from USA, which is capable of warping the yarn in sheet form. It has a capacity of 25000 meter to warp yarn in a ball.
- ADML has a world's best MORRISON Indigo dye range machine from USA, which is capable of doing color like bottoming, topping, reactive colored denim, Sandwich and very deep indigo shades.
- ADML has modern Weaving machine from Belgium. ADML uses the most modern weaving machine in air-jet version to get good production and to make trouble free fabric even if it is made with coarser slub or finer yarn. The loom shed is totally humidified and temperature controlled with enough air circulation and sufficient pressure to help machine make better fabric and always make the shed clean.
- On the finishing side, ADML has machine from MORRISON textile co. of USA, which is the most modern finishing range introduced in Bangladesh for the first time by Amber. Sufficient brushing, singeing in both side, high quality skew device, bigger padder, dryer and compacting device to make the fabric more clean and maintain shrinkage & moisture properly.





- Amber was the pioneer of starting Flat finish fabric commercially in Bangladesh and is capable of doing a variation in flat quality as per the buyer's requirement. They can make Soft Finish, Flat Finish, and Soft Finish Stenter as well.
- On the quality side, Amber uses most modern and efficient lab instruments from UK which is operated by trained technicians. Light box, Spectrophotometer, Rubbing tester, Washing Fastness, Tensile strength etc. gives accurate results and helps to keep quality good and more consistent.
- The R&D department is independent and equipped to promptly invent new designs for new fashion and develop buyer's requirement timely. This department keeps all documents from dyeing recipe to finishing and keeps master roll to keep shade in same consistent even over a longer discontinuity. Amber always researches to develop new fashion as per the world requirement as well as to maintain comfort & durability.
- On the environment side, ADML maintains a state of the art Water and Effluent Treatment Plant meeting toughest international standards, and always looks to make the working environment greener. It has plenty of lush trees surrounding the plant premises. Amber maintains labor laws, gives all facilities like medical, housing, leave, festival bonus etc. to their employees.

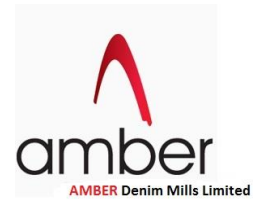


### 1.5 Working-Time Schedule of the Factory

The factory runs 24 hours a day. It maintains a tight work schedule. It follows mainly 3 schedules. i.e.

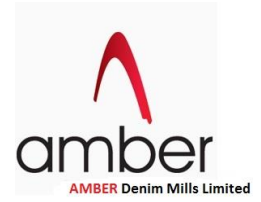
- A-shift: 6 a.m. - 2 p.m
- B-shift: 2 p.m. - 10 p.m &
- C-shift: 10 p.m. - 6 a.m

Section	Number of Shift	Duration
Top Management	General Shift	9 a.m. – 5p.m.
Stuff & Commercial	General Shift	9 a.m. – 5p.m.
Warping	2	12 hours each
Dyeing	3	8 hours each
LCB	2	12 hours each
Sizing	3	8 hours each
Weaving	3	8 hours each
Finishing	3	8 hours each
Utility	3	8 hours each
Security	3	8 hours each

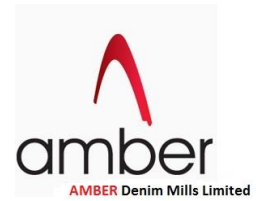


## 1.6 Types of Machines Used in Amber Denim Mills Ltd.:

Section	Machine Name	Brand Name	Origin	Model	Quantity
Warping	Ball Warping	Morrison	USA	450BW	4
		Karl Mayer	Germany	N/A	1
	Sectional Warping	Karl Mayer	Germany	N/A	1
Dyeing	Rope Dyeing	Morrison	USA	N/A	1
LCB	Long Chain Beaming	Morrison	USA	MDS-RB 550	12
		Karl Mayer	Germany	N/A	2
Sizing	UKIL Sizing m/c	UKIL Machinery	Korea	GSSM-100 expert sizer	2
	Karl Mayer Sizing Machine	KARL MAYER Royal SMR	Italy	N/A	1
Weaving	Air jet m/c	PICANOL	Belgium	OMNI Plus 800	176
	Rapier loom m/c	PICANOL	Belgium	N/A	4
Finishing	Sanforizing	Morrison	USA	N/A	2
	Finishing m/c	N/A	China	N/A	1
	Clip Chain Mercerizing m/c	N/A	China	M5469-700x10	1
Washing	Stenter m/c	N/A	China	M5469-700x10	1
	Washing m/c	YILMAK	Turkey	HBM 250S	1
	Hydro Extractor m/c	N/A	N/A	N/A	1
	Laundry Dryer M/C	N/A	N/A	N/A	1



**Chapter Two**  
**Denim & Yarn**



## Denim & Yarn

### 2.1 What is Textile?

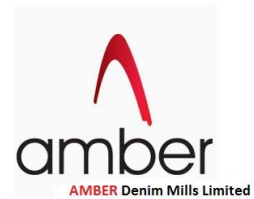
The word “textile” originally applied only to woven fabrics, now generally applied to fibers, yarns, or fabrics or products from yarns or fabrics. The term textile originates from the latin verb texere to weave but, as the Textile Institute’s Terms and Definitions Glossary explains, it is now ”a general term applied to any manufacture from fibers, filaments or yarns characterized by flexibility, fineness and high ratio of Length to thickness.

### 2.2 What Is Denim Fabric?

Denim is a cotton or cotton/polyester blend, durable heavy weight twill weave yarn dyed fabric. Denim (which gets its name from the French city of Nîmes (de Nîmes) is a rugged cotton twill textile, in which the weft passes under two or more warp threads. This twill weaving produces the familiar diagonal ribbing of the fabric, which distinguishes denim from cotton duck. It is characteristic of any indigo denim that only the warp threads are dyed & the weft threads remain plain white. As a result of the warp-faced twill weaving, one side of the fabric shows the blue warp threads, the other side shows the white weft threads. This is why jeans are white from the inside and what makes their fading characteristics so unique compared to other fabric.



Figure 1: Denim Fabric



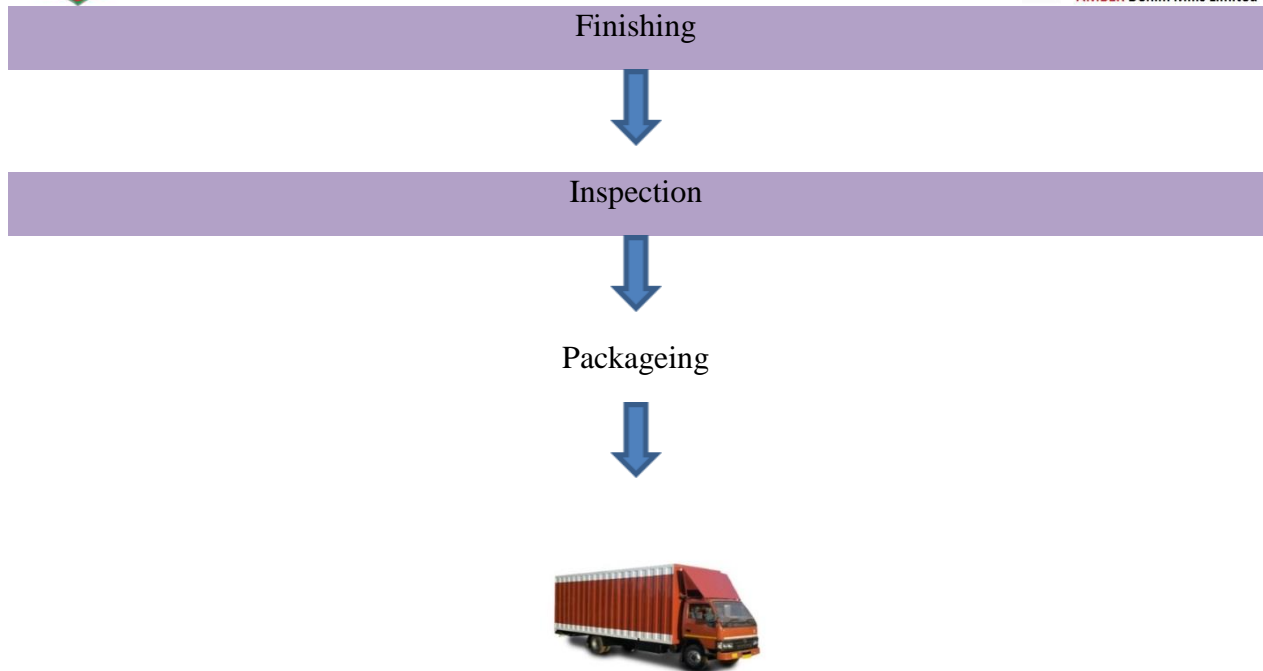
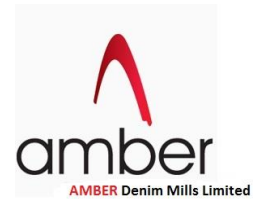
### 2.2.1 End Uses of denim Fabric

Denim was previously used by workers. They wore raw denim clothes because of its high durability, it was extremely strong and perfect for their daily jobs. Now in modern world, the apparels made from denim have become very popular among wearing. Now-a-days, denim is used for making jacket, men's trouser, baby wear, shirt's, ladies wear and day by day, its acceptability is increasing among consumers. Denim goods are now used among almost all type of people. Now denim is so versatile. Denim wear crosses the line of fashion boundary. It is also used for making decorative cap and ladies handbag, school and college bag, and travel bag. So, range of denim apparels are spreading day by day. So Denim is used for jacket, pant, shorts, shirt, skirts, suits, hats, belts, boots and athletic shoes, denim wine bags, denim pencil case, denim apron, denim pillows, denim quilt, lampshades, upholstery etc. Now denim is also used to make sunglass frame for spreading fashion items.

### 2.3 Production Process Flow Chart of Denim Production







## 2.4 Yarn Quality:

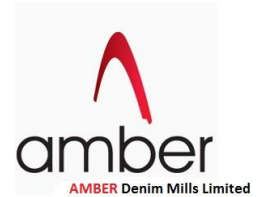
In order to produce good quality denim, the yarn quality used for denim production should be optimal. In rope and slasher dyeing machine the passage of yarn is very long. Hence it is necessary to control the lapping of yarn in the passage of yarn, otherwise problem of high and low densities will be formed in the yarn, which ultimately cause shade variation in the fabric. This leads a huge loss of fabric. Therefore the quality of the yarn is to be appropriate to avoid any snarling properties of yarn during running through the passage & making of fabric.

In the past 1990s, the majority of yarns used in denim production were OE (open ends) yarns. However, recently, there is a strong demand of using more carded ring spun yarns in both warp and weft, which gives the fabric a softer handle.

The quality of carded OE or ring spun yarns used for denim production is as follows:

- Minimum staple length: 2.7cm
- Short fibers proportion (less than 12 mm long)
- Micronaire value: should be in between 4.0 -4.5
- Twist factor: 4.5 to 5.0 for warp yarns & 4.2 for filling yarn,
- Low hairiness, low neps
- Good yarn strength and more uniformity.





## 2.5 Elastic Denim Yarns:

Core-spun yarns are produced conventionally on ring-spinning machines by introducing a spandex filament at the back of the front drafting roll of the machine. The drafted cotton fibers twist around the spandex core to produce an elastic ring-spun type yarn.

## 2.6 Types of yarn used:

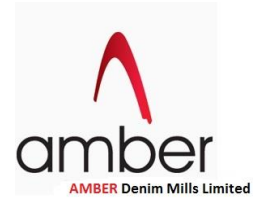
- Rotor yarn
- Open Ends yarn
- Ring card yarn
- Slub yarn
- Polyester
- Lycra yarn

## 2.7 Yarn count used:

- For warp: 6, 7, 8, 9, 10, 12, 14, 16, 20, 30 (Slub +Normal)
- For weft: 6, 7, 8, 9, 10, 12, 14, 16, 20, 30 (Slub +Normal)
- Polyester: 300D, 600D
- Lycra: 10L40D, 16L40D, 150L70D, 200L40D

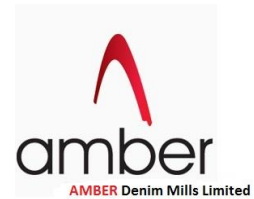
## 2.8 Suppliers of Yarn:

- Amber Rotor Mills Ltd.
- Amber Rotor Spinning Mills Ltd.
- Amber Cotton Mills Ltd.
- Square Textile Ltd.
- Envoy Textile Ltd. etc.



## Chapter Three

# Ball Warping



## Ball Warping

### 3.1 About Warping:

In textile sector, warping is the first process of fabric manufacturing. Warping can be defined as the parallel winding of warp yarn or warp ends from cone, cheese packages on to a beam i.e. warp beam. According to ensure quality of fabric, warping should be done by using required quality of yarn packages. Otherwise, fabric quality will be damaged. In weaving section of textile factory, low quality warp beam is one of the main reasons of fabric damage.

### 3.2 Importance of Warping:

- It helps to buildup of parallel yarn sheet.
- Warping is considered as the combination of various packages.
- It helps to modify various faults of warp yarn such as large knots, thin place and thick place etc.
- It helps to buildup of warp beam by using required quality warp yarn.
- It also helps to wind the predetermined length of warp yarn in the warp beam.
- It ensures long length of warp yarn which is too much helpful for fabric production.
- It also helps to accelerate the next process for woven fabric production.

### 3.3 Types of Warping:

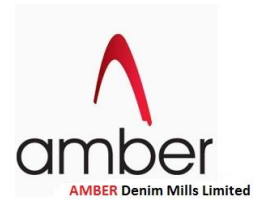
- Sectional or Pattern Warping (conical drum or dresser warping).
- Direct Warping (preparatory beam warping).

#### 3.3.1 Direct Warping:

It denotes the transference of ends from single-end yarn packages, directly to a beam in a one step process. This means that there are an equal number of packages in the creel area as there are ends on the beam.

#### 3.3.2 Sectional Warping:

In sectional warping sections are made sequentially and because of this the process is rather slow. It is the practice therefore to produce no more than is required to fill a single weaver's beam. The result is that the sectional warping is used mainly for short runs or for complex color patterns. To produce Fancy fabric (stripe/Check), producing weavers beam from yarns which does not required any sizing material applied before weaving, sectional warping is done.



### 3.4 Difference between Direct & Indirect Warping:

Direct Warping	Sectional Warping
To produce common fabric	To produce fancy fabric
High production	Low Production
Weavers beam is produced after	Weavers beam is produced before sizing
Single yarn is used	Twist yarn is used
Uniform tension is required	No uniform tension is required
Mostly used warping	Not mostly used
Large amount of yarn are required	Small amount of yarn are required

### 3.5 Ball Warping process:

The main object of ball warping is to prepare log for the rope dyeing machine. Here magazine type of creels is used for creeling the yarns in the form of cheese. Yarns are bought together & make onto a rope form before being wound onto a short cylindrical beam. The supply yarn packages are placed onto a spindle in creel zone. The number of ends taken as per requirement of further processes that is for preparing the weavers beam. Length of rope on log is generally declared on buyer's requirement. The sheet of yarns passes through the reed where lease are inserted, these facilities denting the long the chain beaming. Lease are inserted at regular intervals which can set automatically on the machine .generally after every 500 meters, lease are given. Lease also help in yarn separation in LCB.

### 3.6 Warping section in Amber Denim Mills Ltd. (ADML):

The warping section of the Amber Denim Mills Ltd. is working under the G.M. of Preparatory Section. MDS 450BW ball warping machine with Custom Magazine Creels are used here. The department is connected with dyeing section directly and working 24 hrs. R&D department inspects the cones which is converted in beams of required length and forwarded to dyeing section.

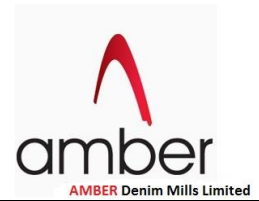


Figure 2: Ball Warming Machine

### 3.7 Specification of Ball Warming Machine:

<b>Machine Name: Morrison Ball Warming Machine</b>
Origin: USA
Model No: MDS (450BW)
Winding Speed: 300-350 meter/min (Avg)
Creel Capacity : 456
Maximum Length of yarn: Around 25000 meter
Yarn type : Both Ring & open end yarn
Maximum Beam Diameter: 1200mm
Number of Machine in Amber: 4





<b>Machine Name : Karl Mayer warping machine</b>
Origin : Germany
Type: BW-160
Machine No: 117094 1220mm 48 Inch
Construction Year: 2015/08
Creel Capacity : 528
Winding Speed : 400 m/min (Average)
Yarn Type : Both Ring & Open End yarn
Number of Machine in Amber: 1

### 3.8 Machine Main Parts:

Creel Zone	Creel Stand Post Post Controller Ballon Breaker Tension Disk/Yarn Tensioner Ceramic disk Yarn Guide Stop Motion
------------	--

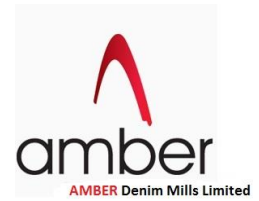
Reed Zone

Guide Zone

Count Meter

Trumpet

Eye pot/ Pot Eye



## Headstock

### 3.9 Description of Different Parts of Machine:

#### 3.9.1 Creel:

Creel Zone is one of the main parts of Morrison ball warping machine. Here the yarn package is set on the spindles of creel. Also a reserve yarn package is placed beside the running package. The tail end of the running package is knotted with the start end of the reserve package. When the running package is depleted, the warper continues to run with the from the reserve package. In ADML, the creel capacity in Morrison ball warping machine is 456 creels.





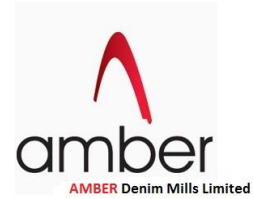


Figure 3: Creel Zone

### 3.9.1.1 Some parts of Creel Zone:

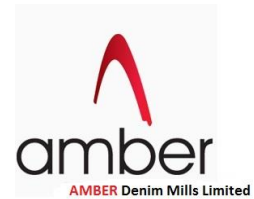
- Bobbin Holder: To hold the Yarn Package.
- Cone Stand: To hold up the creels
- Tension Disk: Tensioner unit two or three posts fitted onto a flat base. Two round disks are placed onto each post. The yarn is passes between the disks. Out of the two or three post, one is movable. This varies the angle of wrap, which apply different levels of tensions to the yarn. The tension on the yarn can be increased by adding weights onto the op weights. This type of tensioners is inexpensive, simple to thread up, require less maintenance.
- Balloon Breaker: Yarn passes from package in balloon shape for properly unwinding.
- Post: It holds the tension disk, guide, post controller. There are 38 post in creel zone.
- Post Controller: It is an electrical device which has stop motion. If there is any breakage of yarn then the post controller gives signals.
- Guider: Yarn guides through the guider to reed zone.

### 3.9.2 Reed Zone:

All the yarn from creel zone age guided through reed zone in sheet form. After leaving the creel, the yarn passes through the reed. The object of reed zone can be said to differentiate each yarn & to remove adjacent of yarn so that they don't create knot. Each alternate yarn is guided into one alternate reed. Here lease is given in every 500 meter of warping to achieve uniform quality of warping & make advantages for LCB section.

### 3.9.3 Count Meter:

All the yarns from reed zone are guided towards the count meter. Here yarns are assemble together to make rope form.



### 3.9.4 Guide Zone:

Yarn from count meter is guided towards guide zone.

### 3.9.5 Eye Pot:

Yarn from guide zone is heading towards eye pot. Here all the yarns are assembling together well & create the rope uniformly.

### 3.9.6 Trumpet:

Yarn from eye pot is guided towards trumpet. It drives into the headstock & gives motion to warp the ball.

### 3.9.7 Headstock:

Headstock is one of the most important parts of ball warping. Here the ball is set & the rope form of yarn travels inside the trumpet and warp into the moving ball with proper tension.

### 3.9.8 Control Panel:

Fully Automatic ball warping machine is controlled through the control panel. Here speed of machine, length of the ball, tension of machine, yarn breakage etc. all can set & identify.

### 3.10 Tensions in Ball Warping Machine:

In Amber denim Mills Ltd. ball warping machine, three tensions are given in the ball warping. These are:

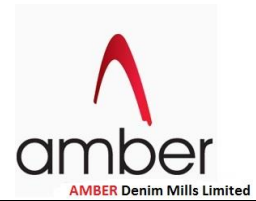
Front Tension: Tension of yarn is kept in post (1-19).

Rear Tension: Tension of yarn is kept in post (20-38)

Jog Tension: During starting of warping ball, yarn has a wind tension that is about 3 meter & that tension is called jog tension.

Ball Warping standard tension setting (for Morrison machine):

Yarn Count		Tension %		
		Jog	Front	Rear
6,7	OE/MS/RS/RC	94	89	94
8	OE/MS/RS/RC	82	77	82
9,10	OE/MS/RS/RC	77	72	77



12	OE/MS/RS/RC	62	57	62
14,16	OE/MS/RS/RC	52	47	52
24,26,28	OE/MS/RS/RC/R.Combed	37	32	37
30,32	OE/MS/RS/RC/R.Combed	32	27	32
34,40	OE/MS/RS/RC/R.Combed	22	17	22

### 3.11 Humidification:

The moisture content of fibers or yarn has an important effect on their, Dimensional Stability, Strength or Electrical Properties.

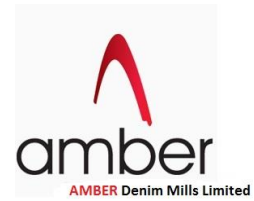
Relative Humidity (RH %) is defined as the ratio of the actual vapor pressure to the standard vapor pressure at the same temperature expressed as percentage. The moisture holding capacity of air increases dramatically with the air temperature. In practice RH indicates the moisture level of the air compared to the air's moisture holding capacity.

All textiles are hygroscopic. They absorb or release moisture depending on the relative humidity of the surrounding air. If the atmosphere is drier than the textile's equilibrium relative humidity then the textile will give up its moisture to the air. If the air is very humid then the textile's moisture content will increase. This moisture loss and gain occurs at every stage from the initial processing of the fibers through to final garment manufacturing, distribution and use by the consumer.

This change in moisture content has a direct impact on the properties of textiles, such as tensile strength, elasticity, fiber diameter and friction. A drop in the equilibrium relative humidity of a textile may cause it to be weaker, thinner, less elastic and therefore more brittle. It will also have more imperfections. By maintaining the air humidity by processing the fibers, this loss in moisture to the atmosphere is minimized.

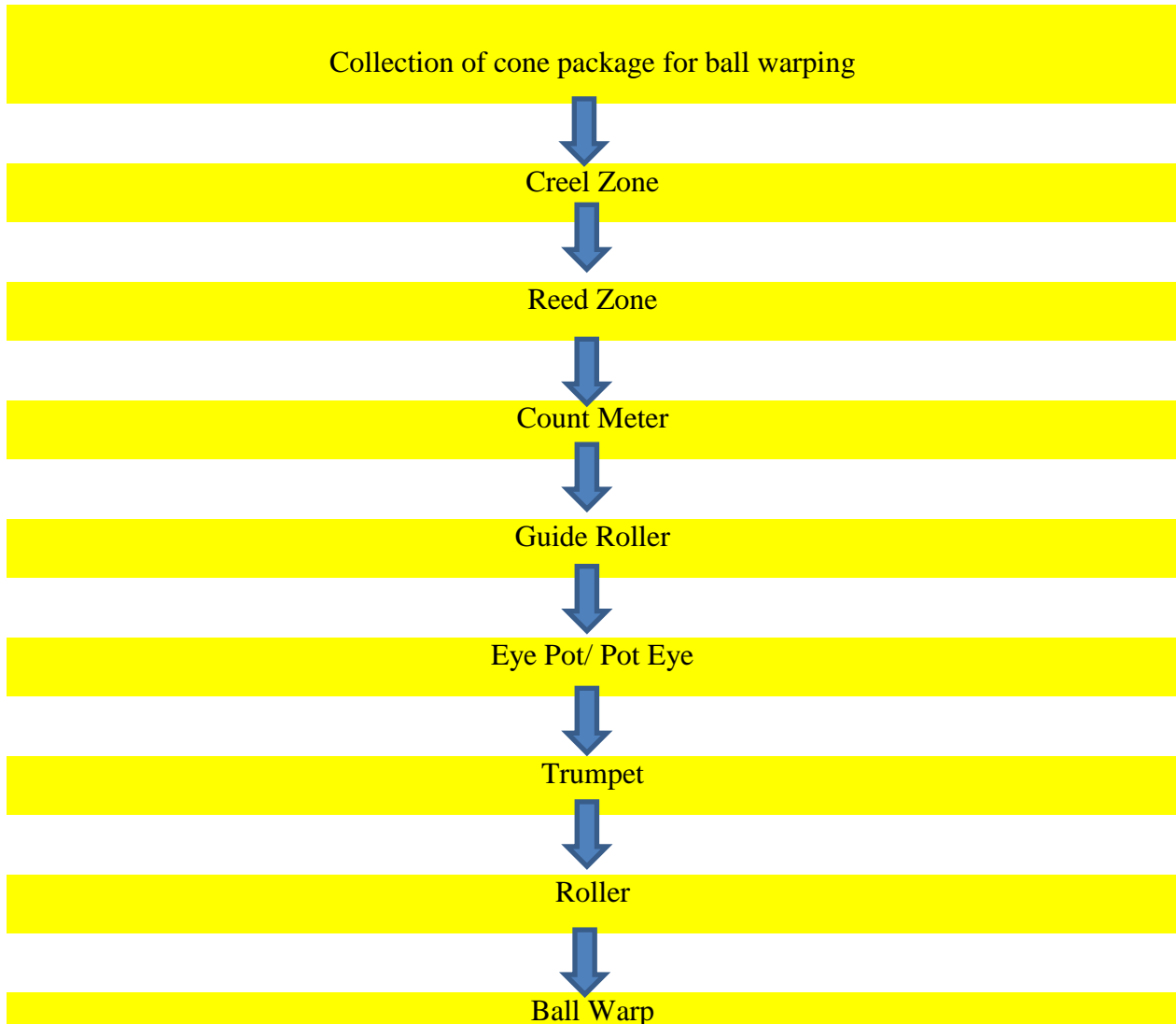
General reasons for controlling RH % and temperature in a textile mill:

- Dry air causes lower regain and this contributes to poor quality and lower productivity.
- Yarns with low moisture content are weaker, thinner, more brittle, and less elastic; create more friction to static electrification. Materials with optimum moisture content are less prone to breakage, heating and friction affects the handle better, have fewer imperfections are more uniform and feel better.
- Higher humidity reduces static problems. Reduced static makes materials more manageable and increases machine speed.
- Textile weights are standardized at 65% RH (+-2) and 20°C. Low humidity causes lower material weights and lowered profits.



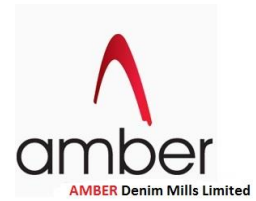
- Humidification reduces fly and micro dust, giving a healthier and more comfortable working environment.

### 3.12 Process flow Chart of Ball Warping:



### 3.13 Process Description:

Yarns from the cone package are unwound & passed through the balloon breaker. Then the yarn passed through the tension disk & from tension disk it is guided through the ceramic disk. Then the yarn is guided through the reed zone. There individual yarn is pass through the reed for reduce the formation of knot in between the yarn. Then the yarn is traveled through the count meter to assemble together. Then from count meter yarn guided through the guide zone & to eye pot.



Rope of yarn is made onto the eye pot. Then the rope of yarn is travelled to the trumpet & then from trumpet the yarn is wound into the ball by moving motion of trumpet into the headstock.

### 3.14 Troubleshooting:

- If there is any breakage of yarn then the operator gives knot with the breakage parts.
- Machine can be set first or slow run if there is no problem in warping or if there is problem in lease.
- Optimum pressure can be controlled.

### 3.15 Calculation:

#### Problem: 01

If Weight of Bag: 50Kg

Total Number of Cone: 30 Count: 9OE

Then find out the length of yarn in one cone.

#### Solution:

Per cone weight = total weight of cone /total no of cone

=50/30

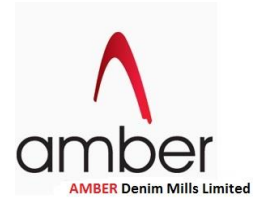
=1.667

Length of yarn in one cone = weight ×count

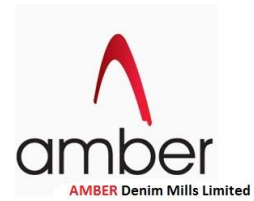
=1.667×2.2046×840 × 9/1.0936

=25405.6 meter

**Answer:** Length of 9 OE = 25405.6 meter



**Chapter Four**  
**Denim Dyeing**



## Denim Dyeing

### **4.1 About Dyeing:**

Dyeing in textiles is a process in which color is transferred to a finished textile or textile material (like fibers and yarns) to add permanent and long-lasting color. It can be done by hand or by machine. Dyes can appear as powders, crystals, pastes or liquid. When the textile and the dye come into contact, the textile is completely saturated by the dye and colored. Dyes actually change the crystal structure of substances. The dye solution or dispersion is always done in an aqueous medium. The major objective of the fixation step is normally to ensure that the colored textile exhibits satisfactory fastness to subsequent treatment in aqueous wash liquors. Dyeing is mainly depends on the type of fabric, structure of fabric and the properties of dyes.

### **4.2 Objective of Textile Dyeing:**

- To make the textile goods suitable for decorative purposes.
- To increase the attractiveness of the textile goods.
- To increase the reflection of light from the cloth.
- To create fashionable cloths.

### **4.3 Denim Dyeing:**

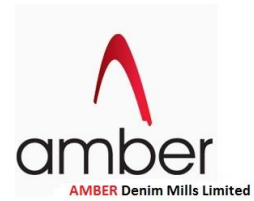
Classical jeans were produced out of indigo-dyed Denim fabric. The special character of this fabric – only the warp thread is dyed makes it necessary to carry out dyeing in rope form.

Indigo is considered as the primary color of blue jeans, it is an important dyestuff with unique shade of blue color. The dye gives a brilliant shade and eye catching blue color to the fabric. Indigo has a low affinity for cotton, therefore deep blue dyeing's only possible when and oxidation is done several times. The color partially penetrates the yarn, and imparts the surface blue color. The dye then fades gradually fades from the surface of the fabric naturally.

There are two types of denim fabric dyeing. They are indigo dyeing and Sulphur dyeing. Indigo is considered as the primary color of blue jeans, it is an important dyestuff which has unique shade of blue color. This dye gives a brilliant shade and eye catching blue color to the fabric. Indigo has a low affinity for cotton, therefore deep blue dyeing's only possible when and oxidation is done several times. The color partially penetrates the yarn, and imparts the surface blue color. The dye then fades gradually fades from the surface of the fabric naturally.

Sulphur dyeing, which also called color denim is used to produce particular colors like black, cherry, grey, rust, mustard and lime, and also to get better the quality.

Both of them are insoluble in water and have a very poor affinity to cellulose fibers like cotton fiber. In normal situation, vat dyes will not attach onto cotton fiber. For dyeing of cotton yarn with vat dyes, vat dyes should be transformed into water-soluble leuco form via chemical



reduction process, in which hydrogen is liberated. The hydrogen reacts with the dye and allows a water molecule to attach to the dye. The dye is then carried into cotton fiber by the media of water. Sodium hydroxide is one of the reducing agents used to convert vat dyes into water soluble form. The dye is attached onto cotton fiber by the water. Removing the hydrogen makes the dye insoluble and results in the dye becoming physically trapped inside the fiber.



Figure 3: Vat dyes

#### 4.4 Process of denim dyeing:

The unique feature in the manufacturing of denim fabric is the dyeing of the warp yarn through a long chain Indigo Dye Range. The logs/ropes of yarns from the warping process called "Ball warps" are loaded at the creel zone of dyeing machine and are processed through a series of boxes which contain dyestuffs to build the shade and used of other boxes that rinse the yarn of excess dye. Between boxes, the ropes are exposed to air in a process known as skyer, where oxidation or fixing process of the dye takes place. At the end of the range, the yarn is passed over steam heated dry cans for drying & then put those rope in coiler & ready for next process.

#### 4.5 Dyes use for Denim dyeing:

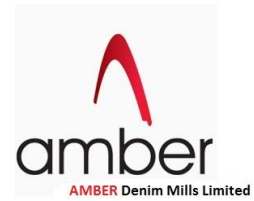
- Vat Dyes
- Sulphur Dyes

##### 4.5.1 Vat Dyes:

The name vat was derived from the large wooden vessel from which vat dyes were first applied. Vat dyes provide best color fastness properties among all the dyes in common use of dyes. The natural and man-made cellulosic fibers are used for dyeing with vat dye. Vat dyes are expensive







and difficult to apply in cellulosic fibers than other classes for cellulose such as direct dyes, reactive dyes etc. Indigo is a special case in the vat dye class. Indigo is attractive for its attractive blue color and well known for its unique fading characteristics. Vat dyes are characterized by the presence of a keto group. Vat dyes in keto form are water insoluble pigments.

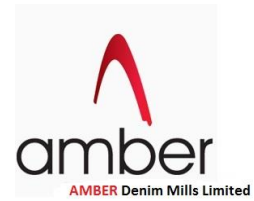
#### 4.5.1.1 Dyeing with vat dyes:

The application of vat dyes to cellulosic materials occurs in five stages. These are:

- **Aqueous Dispersion:** The insoluble vat dye is dispersed in water.
- **Vatting:**  
As vat dyes are water insoluble, this step involves the chemical reduction of the vat dye to produce the soluble and change into leuco form of the dye from keto form. This is achieved by Sodium Hydro sulphate and water. The sodium hydro sulphate reduces the vat dye particles in the alkaline conditions.
- **Absorption of dye molecules by the fiber:**  
The vatted dye molecules are substantive to the cellulosic material when this is introduced into the dye liquor. To achieve adequate exhaustion rate, an electrolyte is added to the dye liquor. The application of the dye molecule to the fiber occurs at temperatures specific to a particular vat dye and occurs in a range from 20° C to 60° C. The addition of the electrolyte alters the equilibrium of the dye liquor so as to increase the substantivity of the dye molecules for the fiber. During this stage of dye textile material must be kept immersed in the dye liquor to prevent oxidation of the leuco compound.
- **Oxidation of dye molecules within the fiber:**  
After the dye molecule penetrates into the fiber surface, the leuco form of the vat dye has to be oxidized and converted to its original shape & color and should convert into the insoluble form of the dye. Oxidation of the leuco compound can be achieved by atmospheric oxygen although this is somewhat slow. In practice, a mild oxidizing reagent such as sodium per borate is used to convert the soluble leuco compound into the original insoluble vat dye.
- **Soaping-off vat dyes:** From the previous stage some insoluble vat dye is deposited entrapped on the surface of the textile material. This has to be removed to prevent poor rub-fastness as well as there will create a possibility of possible changing shade. Soaping-off, which is the boiling of the dyed material in liquor containing some suitable detergent, removes this surface dye. Also rinse by water is done for removing this entrapped dye.

#### 4.5.1.2 Dyeing With Sulphur Dyes:

These dyes are so called because they contain sulphur atoms in their molecules. The fibers most readily colored with sulphur dyes are the natural and man-made cellulosic fibers.



The Sulphur dyes contain Sulphur linkage within their molecules. They are insoluble in water but can be made soluble in water by treating them with reducing agents and make them substantive towards cellulosic fibers. Sodium Sulphite ( $\text{Na}_2\text{S}$ ) acts as reducing agent that breaks the Sulphur linkage and break down the longer molecules in to simple components which can penetrate the fiber surface easily.

## 4.6 Denim Dyeing Process:

There are three processes in the practice for continuous denim dyeing:

1. Rope Dyeing
2. Slasher or Sheet Dyeing
3. Loop Dyeing

### 4.6.1 Rope Dyeing:

The indigo Rope dyeing technology for denim production is considered a superior dyeing technology, which creates better uniform dyeing than other Indigo dyeing technologies like slasher dyeing. Indigo rope dyeing was first started in USA. Typical Indigo rope dyeing range is shown in figure.

Today rope dyeing accounts for a large percentage of warp yarn dyed for denim production. The system offers highest production, can be achieve long length of ends. Due to continuous process, there is no problem of changing the ball or sets. In this dyeing method, maximum continuity of shades and minimum danger of center to selvedge shade variation can be achieved.

In Amber Denim Mills Limited, there is one rope dyeing machine where modern technology of denim dyeing can achieve.

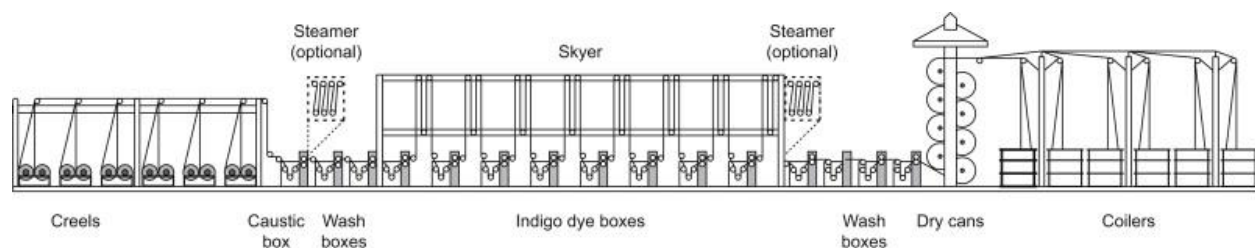


Figure 4: Morrison Indigo Rope Dyeing Range

### 4.6.2 Slasher Dyeing:

Slasher dyeing is a more convenient and reasonable method than rope method because rope dyeing using indigo is not desirable for manufacturers. The step of 10 slasher dyeing is same as rope dyeing before the addition of dyes. For slasher dyeing, indigo is applied in a series of multiple dip and sky application to build up a fairly deep shades. If the arrangement of the slasher dyeing does not allow multiple dips and sky applications, then only light and medium shades can be obtained from indigo.

Slasher dyeing has a number of advantages and unique characteristics. Slasher dyeing employs a sheet of yarn, which is wounded directly onto a warp beam rather than ropes of yarn, so additional handling can be skipped. It can work well with lightweight denims. Moreover, this method requires less machines floor space, suitable for smaller production runs, so it has a quicker turn over time, and is more flexible in its response to changes in the market. This method required lower machinery cost and lower dye costs for specific fabric types. Additionally, the slasher dyeing technique can be used for other cotton dyes and thus can produce a wide variety of colours other than indigo blue

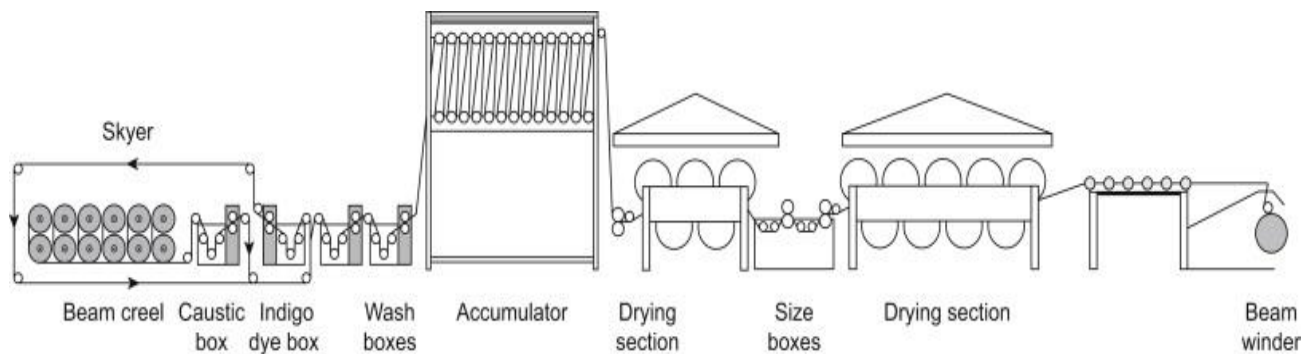
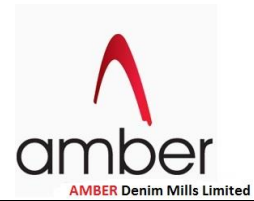


Fig 5: Schematic diagram of a typical sheet dyeing range

### 4.7 Difference between Slasher Dyeing & Rope Dyeing:

Comparison On	Rope Dyeing	Slasher Dyeing
Required Space	More	Less
Manpower	More	Less
Dye bath	More	Less
Flexibility	Less flexible. Difficult to change colors.	Flexibility to produce denim in different colors and small quantities
Extra ends	No extra ends.	Extra ends Required.



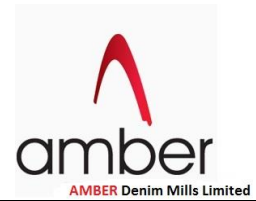
Count range	Large numbers of yarns are difficult to open at re-beaming. Hence it is not suitable for fine yarn. Can use Ne1-16 without major change. In latest machines even higher yarn count can be dyed.	Advantages for lighter yarn. Can use Ne 1-30 without major change.
Different colour mixing	Possible to mix ends of different colours. One can get stripe design at re-beaming.	Not possible
Cost	Cost of production is more compared to sheet Dyeing	Cost of production is lesser compared to Rope Dyeing
Dye dipping time for effective dye	< 21s ( standard 15 – 21s regulated by speed)	< 14s ( standard 10 – 14s regulated by speed)

#### 4.8 Dyeing Section in Amber Denim Mills Limited (ADML):

In dyeing section of Amber denim Mills Limited, there are one rope dyeing machine where dyeing operation has been done.

#### 4.9 Machine Specification:

Machine Name	Morrison Textile Dyeing Machinery Ltd.
Origin	USA
Model No.	T-1178
Manufacturing Year	2011
No of Creel	37
No of Box	15
	Pre Wetting Box: 1
	Pre Wash Box: 2
	Dye Box: 8
	Post Wash Box: 3
	Softening Box: 1
Number of Rollers	258 (Include Dryer)
No of Dryers	36 (12 rollers in a row, 3 set)



Machine Maximum speed	36 m/min
-----------------------	----------

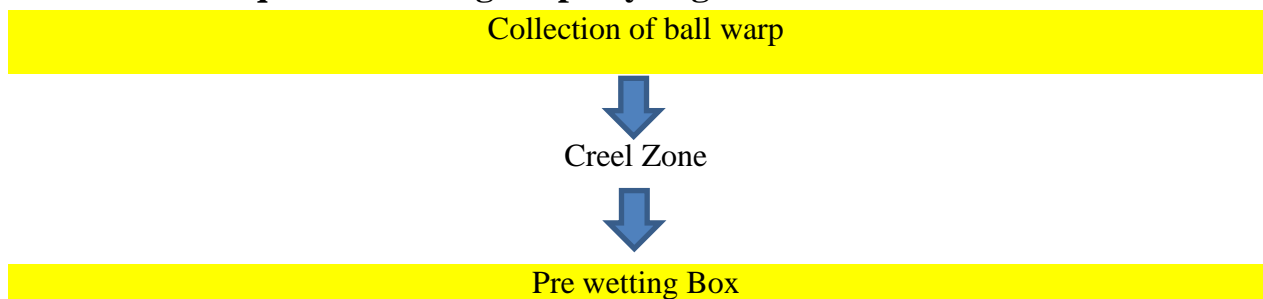
#### Different Box Capacity:

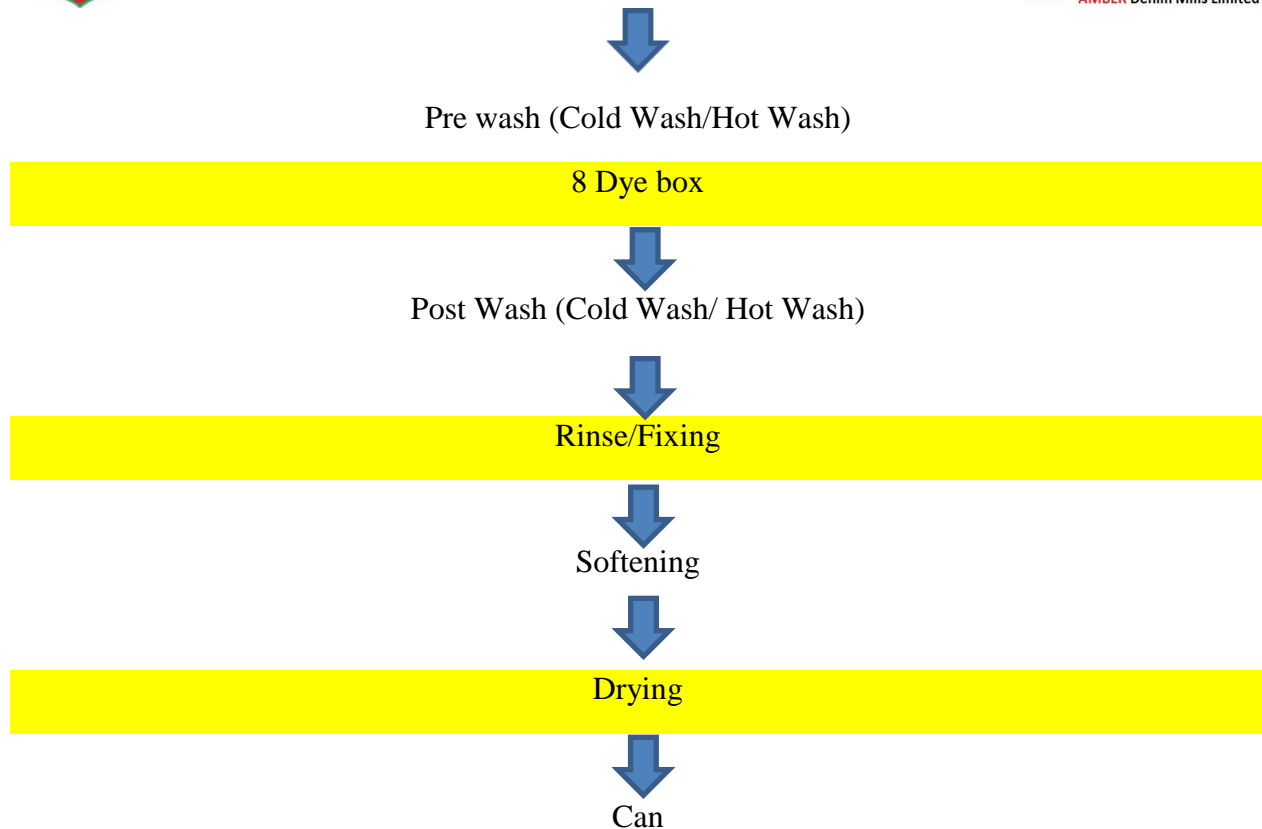
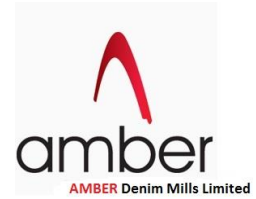
Pre Wetting Box	3000 liter
Pre Wash Box	3000 liter
Dye Box	3000 liter
Post Wash Box	1700 liter
Softening Box	1750 liter

#### Temperature in Box:

Scouring/ Pre wetting box	Scouring (Indigo): 45 <sup>0</sup> -70 <sup>0</sup> c Bottoming :75 <sup>0</sup> -85 <sup>0</sup> c
Pre Wash Box	Cold Wash : Room Temperature Hot Wash: 45 <sup>0</sup> -50 <sup>0</sup> c
Dye Box	Indigo: 30 <sup>0</sup> -35 <sup>0</sup> c Sulphur: 85 <sup>0</sup> -90 <sup>0</sup> c
Post Wash Box	Cold Wash : Room Temperature Hot Wash: 45 <sup>0</sup> -50 <sup>0</sup> c
Softening Box	45 <sup>0</sup> -50 <sup>0</sup> c
Dryer	100 <sup>0</sup> -120 <sup>0</sup> c

#### 4.10 Process sequence in Indigo rope dyeing:





#### **4.11 Dyeing machine main Parts of AMBER denim Mills Limited:**

##### **4.11.1 Creel Zone:**

In creel zone of dyeing machine, 37 warp balls can be set for dyeing. They are set either in three sets (12 in each set) or two sets (14 in each set) according to buyer's requirement. Here the rope of ball gives knot with the attached rope in the dyeing machine (it is huge time needed if new ball is going to full set in dyeing machine. So previous ball's rope end part is attached in dyeing machine).



Figure 6: Creel Zone

#### 4.11.2 Pre Wetting:

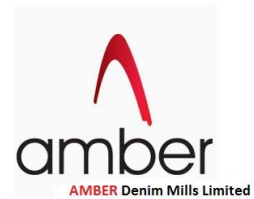
In rope dyeing machine, ropes are first through one pre wetting bath. Caustic Soda, Wetting agent, sequestering agent are some agents which is used in pre wetting box. In case of Bottoming, Hydro (Sodium Hydro sulphate) or glucose is used as reduction agent. The object of pre wetting is to remove the oil, fat, waxes, minerals, pectin etc. from rope of yarn.

Functions of chemical used in pre wetting:

Caustic Soda (NaOH): To maintain the proper alkaline medium for indigo dyeing ( $P^H$  11.8), caustic soda is used.

Wetting Agent: It is known as surface active agent or Surfactant which increase the swell properties of so that dye molecules can easily be penetrated.

Sequestering agent: It is used to decompose the metal ions in water which creates discoloration of fabric & patchy dyeing. It is used to remove the hardness of water.



#### 4.11.3 Pre Wash (Cold Wash/Hot wash Box):

After pre-wetting process, pre wash has been done. In the two pre wash box in dyeing machine, cold wash & hot wash is used. For Cold wash, room temperature is maintained & for hot wash temperature is maintained between 45°-50°c.

#### 4.11.4 Dye Box:

In rope dyeing machine of Amber denim Mills Limited, there are 8 dye boxes which is used for dyeing. The rope of yarn is dipped into the dye box after the pre wash process. After dipping there are skyer situated in the up of each dye box for doing the oxidation process of vat dye. There is a need of repeated dipping & nipping to increase the penetration & acquires the required shade. That is why 8 baths are used for indigo dye.

The dyeing is done on room temperature & oxidation is done by air. In dye box along with indigo, sodium hydrosulphite ( $\text{Na}_2\text{S}_2\text{O}_4$ ) (known as hydrose) is used as reducing agent. Caustic Soda ( $\text{NaOH}$ ) is used to maintain the required  $\text{P}^{\text{H}}$ . The  $\text{P}^{\text{H}}$  range of indigo dyeing should be kept on between 11.5-11.8. At this  $\text{P}^{\text{H}}$ , the affinity of dyeing substances onto fiber is very high.

In case of sulphur dye, all the procedure is same but the reducing agent used for sulphur dyeing is Glucose. The temperature is kept in between 80°-85°C &  $\text{P}^{\text{H}}$  range is kept for sulphur dye is 12-13.





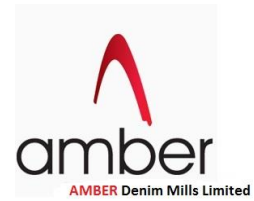
Figure 7: Dye Box



Figure 8: Rollers (Skyer for Oxidation)

#### 4.11.5 Post Wash (Cold wash/Hot wash/rinse/fixation):

After dyeing process there are 3 wash boxes which is called post wash box. The ropes of yarn are washed for removing any unfixed dyes. Rubbing fastness of indigo can be achieved through post



wash process. Cold wash is done in room temperature & hot wash is done at 45°-50°c. Sometimes fixation operation is done in 3rd bath if required.

#### **4.11.6 Softening Box:**

In the last box of indigo dyeing range, softening application is applied with the used if softener. The main object of softener is to easy open of the rope for the next LCB (Long Chain Beaming) process.

#### **4.11.7 Drying & Can:**

After softening, the ropes of yarn go to the dryer. Teflon Coated cylinder dryer helps to dry the ropes of yarn. In the Morrison dyeing machine there are 36 drying cylinder (12 cylinder in a row, assume dryer box. 3 box). Temperature of 1<sup>st</sup> dryer box is less than the 2<sup>nd</sup> dryer box. Temperature is kept in the dryer box is about 100°-120°c. Ropes are dried & passed through the coiler.

### **4.12 Indigo Dyeing process control**

#### **4.12.1 Concentration of Hydrosulphite:**

It is measured by vatometer. It should be from 1.5 gpl to 2.5gpl, or by redox potential of dye bath which should be from -730 mV to -860 mV.

#### **4.12.2 Dye concentration in Dye bath**

It is measured by spectrophotometer. It should be in g/l

#### **4.12.3 Influence of P<sup>H</sup> in shade variation:**

High Indigo Concentration → Shade is greener and lighter

Low Indigo Concentration → Shade is dull and Red.

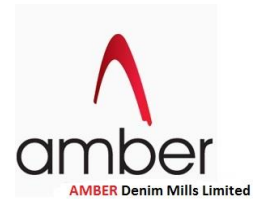
High pH or Caustic Concentration → Redder and lighter

Low pH or caustic concentration → greener and darker

#### **4.12.4 Dipping Time**

Longer the dipping time, better will be the penetration and lesser will be the ring dyeing effect. It varies from 15-22 seconds.





#### 4.12.5 Airing Time

It should be 60-75 seconds. Longer airing time results in high tension on the yarn and subsequent processes will become difficult.

#### 4.12.6 Drying

Insufficient or unevenly dried yarns will result in poor rebeaming.

### 4.13 Types of Denim Dyeing:

There are 4 types of denim dyeing has been done in Amber denim Millis Limited. These are:

- Indigo Dyeing: Dyeing with indigo in 8 dye box to achieve uniform blue shade.
- Sulphur Dyeing: Dyeing with sulphur black in 8 dye box to achieve black shade.
- Topping: In case of topping 5 box is used for Indigo dyeing, 2 box is used for wash & No. 8<sup>th</sup> box is used for topping.
- Bottoming: In pre wetting box, sulphur black is used. Then in dye box, indigo is used.

### 4.14 Dyeing Recipe:

#### For indigo dyeing

Pre wetting Box:

Chemicals	Quantity
Caustic Soda	30 gpl
Wetting Agent	8 gpl
Temperature	45°-70°c
Water	As per required

Pre Wash Box:

Water: Cold wash/Hot wash

Dye Box recipe:

Chemicals	Quantity
Indigo (4.5 % Shade)	3.3 gpl
Hydro Caustic	0.7 gpl
Temperature	35°-40°c
p <sup>H</sup>	11.5-11.8
Water	As per required



Post Wash:

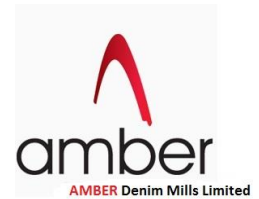
Water: Cold wash/Hot wash/Fixing agent

Softener box:

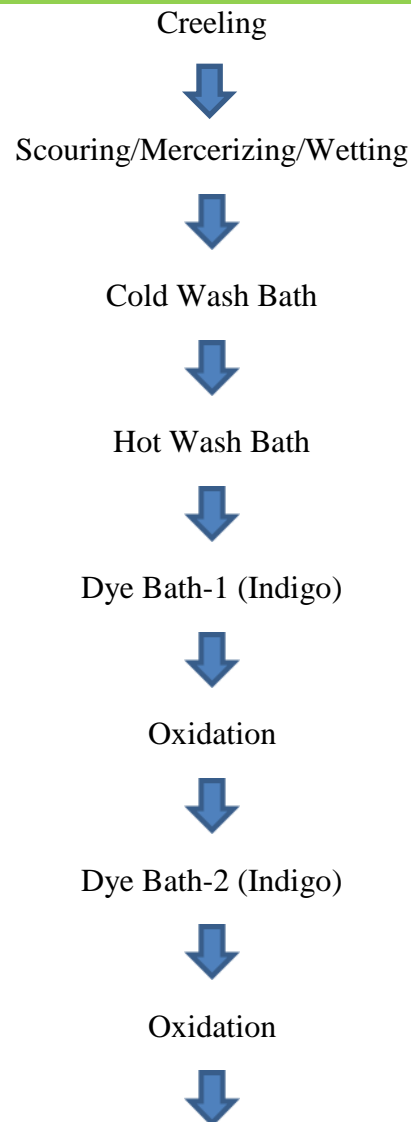
Softener: 5.5 gpl

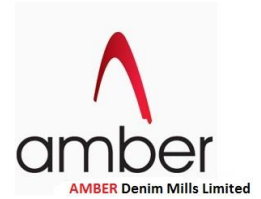
Acetic Acid: If required

Water: As per required



## Process Flowchart for Pure Indigo





Dye Bath-3 (Indigo)



Oxidation



Dye Bath-4 (Indigo)



Oxidation



Dye Bath-5 (Indigo)



Oxidation



Dye Bath-6 (Indigo)



Oxidation



Dye Bath-7 (Indigo)

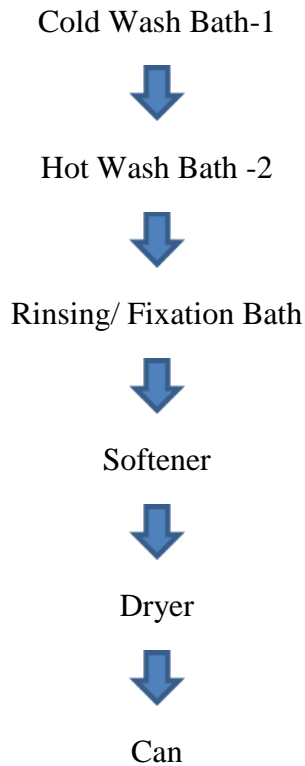
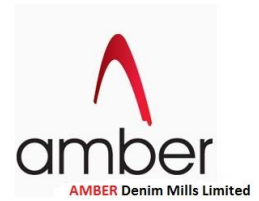


Oxidation



Dye Bath-8 (Indigo)





### For Sulphur Topping:

Pre wetting Box recipe:

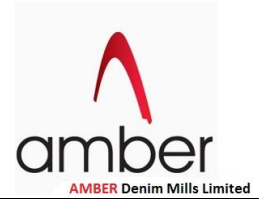
Chemicals/ Components	Quantity
Caustic Soda	85 gpl
Wetting Agent	6 gpl
Temperature	45°-70°c
Water	As per required

### Pre Wash Box:

Water: Cold wash/Hot wash

Dyeing Box:

Chemicals/ Components	Quantity
Indigo (4.5% Shade) (5 box)	3.3 gpl
Hydro Caustic	0.7 gpl
Water	As per required
Temperature & P <sup>H</sup>	35°-40°c & 11.5-11.8
Normal Wash (2 box)	Water as required



Sulphur Black (1 box)	50 gpl
Reducing agent (Glucose)	40 gpl
Caustic Soda	85 gpl
Temperature	80°-85°c

### Post Wash:

Water: Cold wash/Hot wash/Fixing agent

### Softener box:

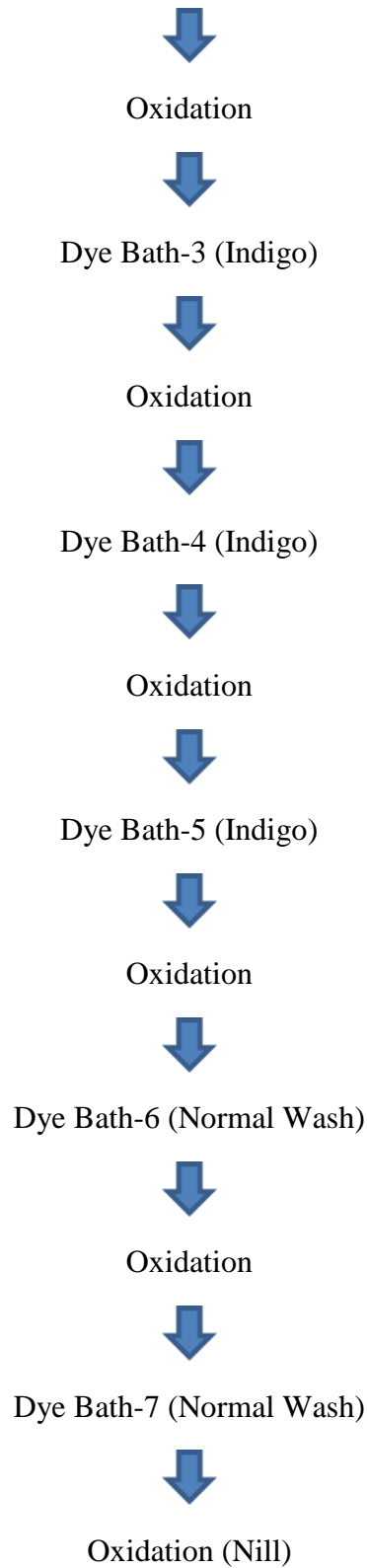
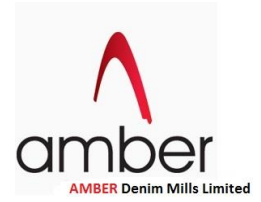
Softener: 5.5 gpl

Acetic Acid: If required

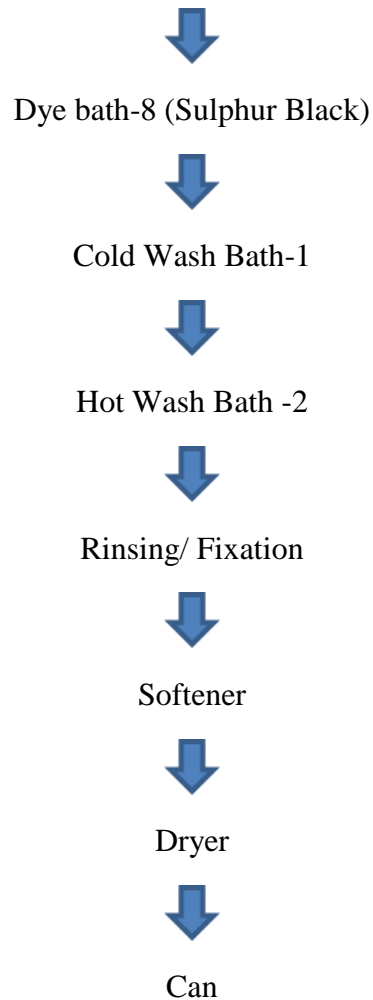
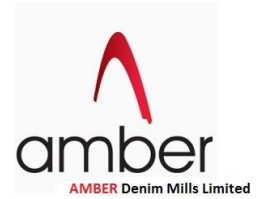
Water: As per require

## Process Flowchart of Sulphur Topping









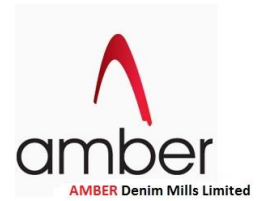
### For Sulphur Bottoming

In Pre-wetting Box recipe:

Chemicals /Components	Quantity
Sulphur Black	4 gpl
Reducing agent (Glucose)	8 gpl
Wetting Agent	7 gpl
Caustic Soda	8 gpl
Water	As per required
Temperature	80°-85°c

### Pre Wash Box:

Water: Cold wash/Hot wash



### Dye Box Recipe:

Chemicals/ Components	Quantity
Indigo	2.8 gpl
Hydro Caustic	0.7 gpl
Temperature	35°-40°c
p <sup>H</sup>	11.5-11.8

### Post Wash:

Water: Cold wash/Hot wash/Fixing agent

### Softener box:

Softener: 5.5 gpl

Acetic Acid: If required

Water: As per required

## Process Flowchart for Sulphur Bottoming

Creeling



Scouring/Mercerizing/Wetting/

Dyeing (Sulphur Black)



Cold Wash Bath

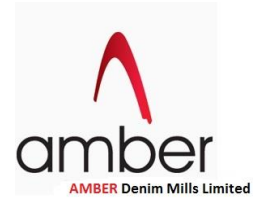


Hot Wash Bath



Dye Bath-1 (Indigo)





Oxidation



Dye Bath-2 (Indigo)



Oxidation



Dye Bath-3 (Indigo)



Oxidation



Dye Bath-4 (Indigo)



Oxidation



Dye Bath-5 (Indigo)



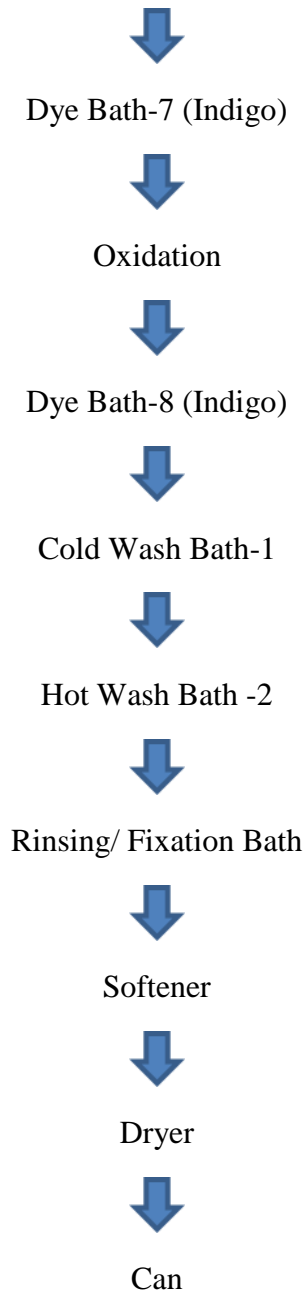
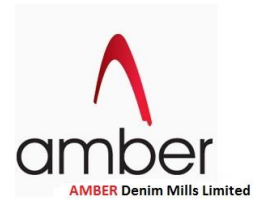
Oxidation



Dye Bath-6 (Indigo)



Oxidation

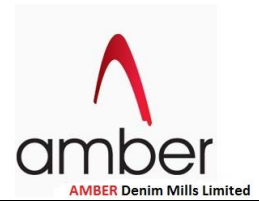


### For sulphur black dyeing:

Pre wetting box recipe:

Chemicals / components	Quantity
Caustic Soda	18 Bhumi





Mercerizing Agent	4 gpl
Wetting Agent	7 gpl
Temperature	45°-70°c
Water	As per required

### Pre Wash Box:

Water: Cold wash/Hot wash

Dyeing Recipe:

Chemicals/ Components	Quantity
Sulphur Black	280 gpl
Reducing agent (Glucose)	8 gpl
Caustic Soda	15 gpl
Temperature	80°-85°c
pH	12.8-13
Water	As per required

### Post Wash:

Water: Cold wash/Hot wash/Fixing agent

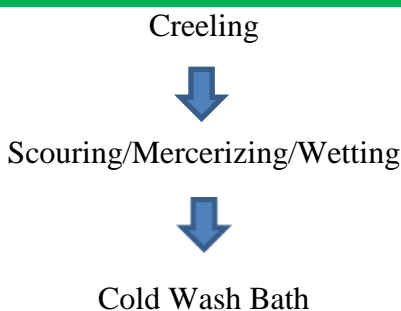
### Softener box:

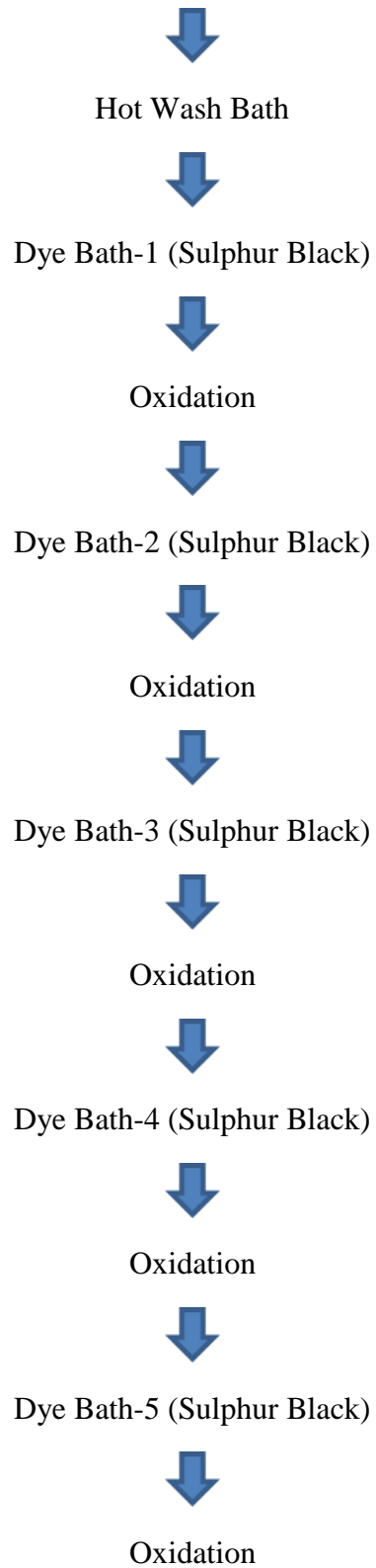
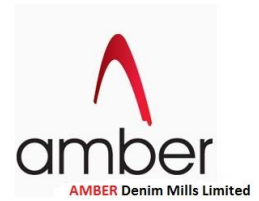
Softener: 5.8 gpl

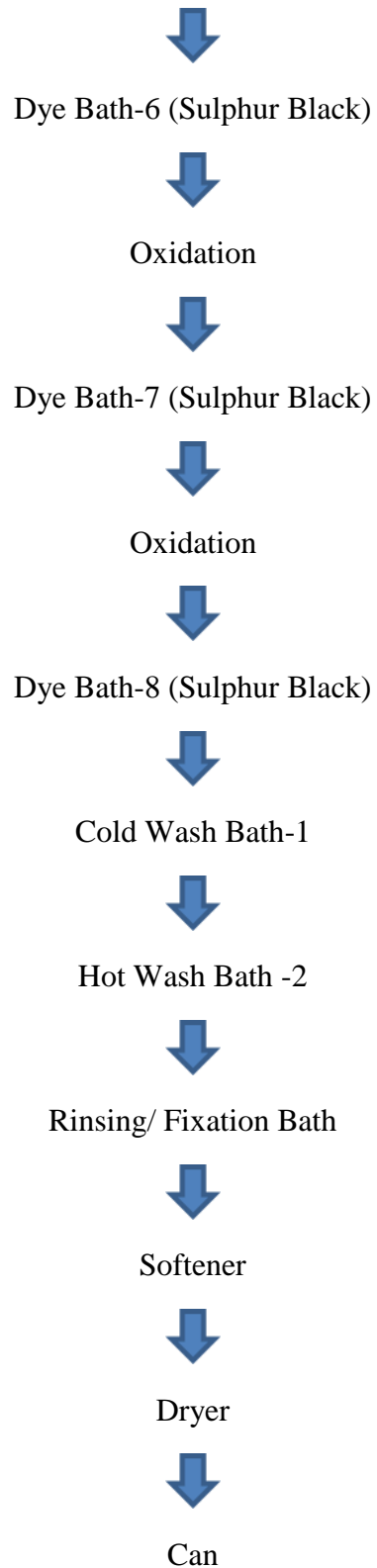
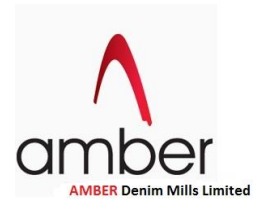
Acetic Acid: If required

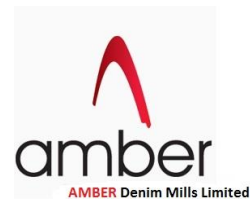
Water: As per required

## Process flowchart for sulphur black














#### 4.15 Chemicals Used for dyeing in Amber Denim Mills Limited:

Chemical Name	Function of Chemical
Benquest	Wetting Agent
Dekol 1097 SP	Sequestering Agent
Benwett RD-999	Wetting Agent
SulfoTEX Black	Sulphur Black
MKS Devo Black	Sulphur Black
Colsul Black	Sulphur Black
Stabifix IND	Fixing Agent
Bensoft 210D	Softening Agent
Diresul black	Sulphur Black
BENVADINE MR-100	Mercerizing Agent
Indigo Blue Genolar	Powder Indigo
Denim Blue 30	Liquid Indigo
Mercerol	Mercerizing Agent

#### 4.16 Equipments/Machines used in Dyeing Laboratory:

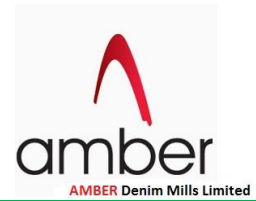
Name	Function	Image of Machine
------	----------	------------------



Color assessment Cabinete	Used for matching color fastness & shade	
Metrohm Meter	Used for checking the P <sup>H</sup> , Indigo (gpl) & hydro (gpl).	
Metrohm P <sup>H</sup> Meter	Used to check the P <sup>H</sup> on the dye bath	
Spectrophotometer	For measuring the purity of sulphur dyeing	
Digital Balance	Used to measuring the weight of lea.	
Dryer	For drying the Lea	

#### 4.17 Troubleshooting:

- If there is any problem in P<sup>H</sup>, It can be controlled by increasing or decreasing Caustic solution.
- If there is blue tone, using of Hydro must be decreased.
- If there is any reddish tone, using of hydro solution is increased.
- Shade can be controlled by increasing or decreasing gpl of indigo.



## 4.18 Calculation:

### Problem No 01:

Given that,

Shade: 4.5%

Count: 9 OE

Total Ends: 5112

Set Length: 11500 m

Find required amount of dye?

Solution:

We know,  $\text{Tex} = 590.5/7 = 65.61$

Weight of 5112 ends =  $65.61 \times 5112 / 1000 = 335.39 \text{ g/min}$

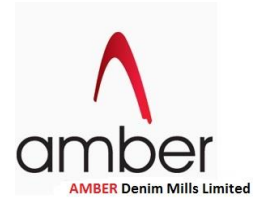
Weight of 11500 meter =  $335.39 \times 11500 = 3856.985 \text{ kg}$

100 gm yarn contain 4.5 gm dye

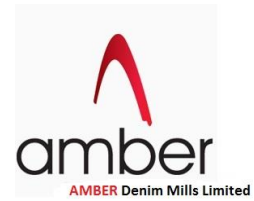
1 kg yarn contain =  $1000 \times 4.5/100 = 45 \text{ gm dye}$

3856.985 kg yarn contain =  $4.5 \times 3856.985 = 173.6 \text{ kg dye}$

**Answer:** 174 Kg dye required to dye 11500 meter yarn of 5112 ends.



**Chapter Five**  
**LONG CHAIN BEAMER**  
**(LCB)**



## Long Chain Beamer (LCB)

### 5.1 About Long Chain Beamer Unit:

After rope dyeing of warp yarn in denim production, the next process is the LONG CHAIN BEAMER (L.C.B). When the rope has been dyeing and dried in the rope dyeing section, it has been taken in the large coiler. The main purpose of the long chain beamer to open the rope in a sheet form of yarn and wind onto a warp beam which is transferred into the sizing machine.

The basic purpose of long chain beamer is to open the rope into a sheet form of yarn and wind onto a warped beam which in turn transferred to the sizing machine.

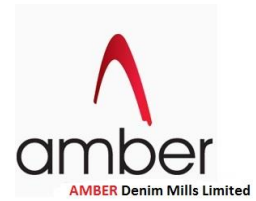
In Long Chain Beamer, the yarn alignment in the dyed rope is change from a rope form to a sheet form. In the Long Chain Beamer the rope pull from the can (Fig) by moving them upward to a guiding device. The guiding device is mounted above the can, probably in the ceiling. The upward movement of the rope allows the ropes to untangle before nearing the beamer head and allow the rope to shake loose form from the rest of the rope in the can.



Figure 9: Long Chain Beamer Machine

### 5.2 Long chain beamer section in AMBER Denim Mills Limited:

In our **AMBER** DENIM MILLS LTD., There are 14 L.C.B machine. There are 12 Morrison long chain beamer machine and 2 Karl Mayer long chain beamer machine.



### 5.3 Machine Specification:

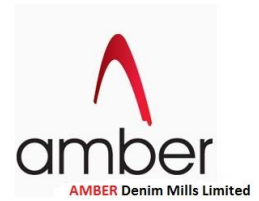
M/C Name	Morrison Textile machinery
Origin	USA
Serial No.	RB-135
Manufacture date	09/2013

### Ukil Machinery Co. LTD:

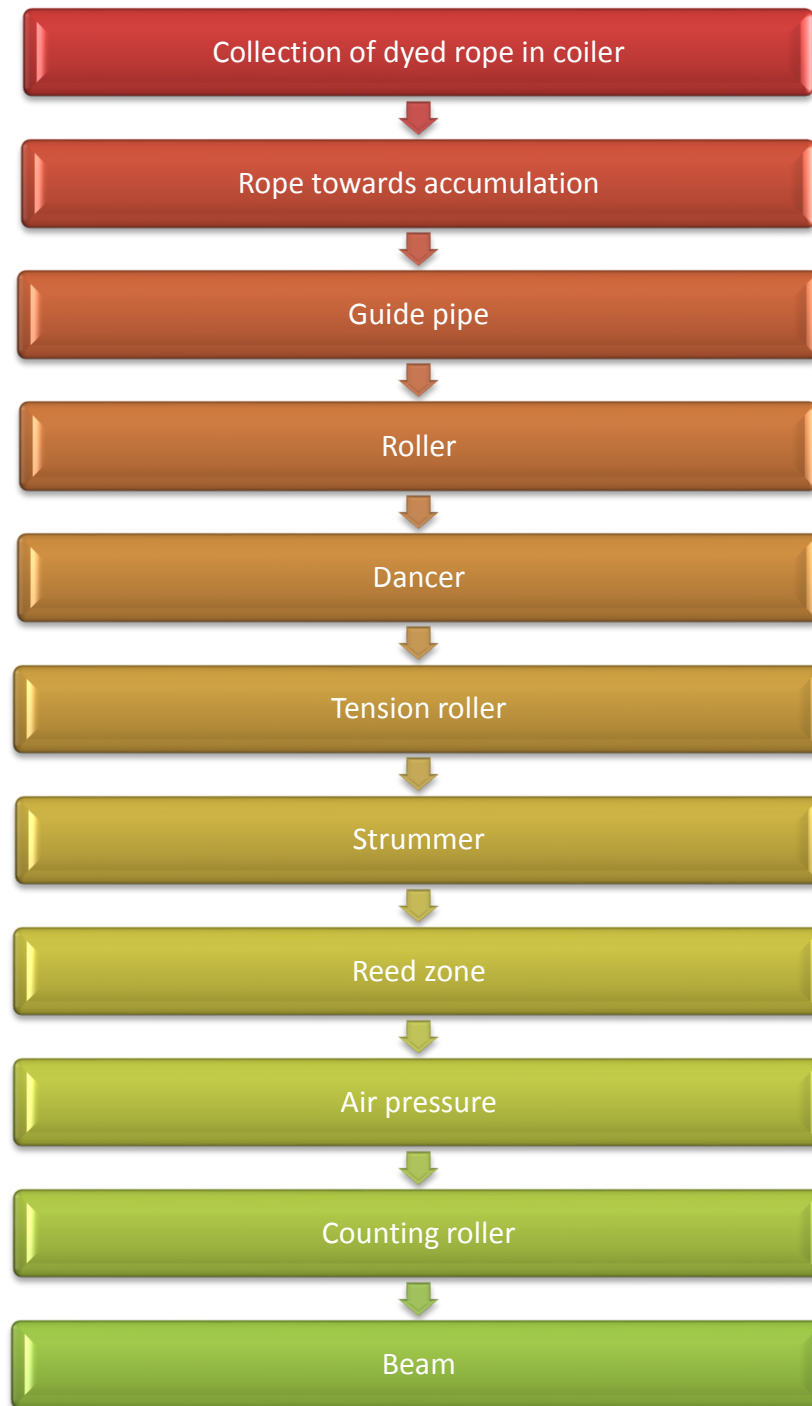
Model Name	MDS-RB 550
Product Name	Long chain Beamer
S/N	RB-135
Main Drawing No.	LCBELE-901

### Karl Mayer Royal SMR:

M/C Name	Karl Mayer
Type	LCB-Titan, 1800mm,71inch
M/C No.	117096
Const. year	08/2015
Origin	Germany
Made by	China



### 5.4 Process Flow Chart of Long Chain Beamer:



## 5.5 MAIN PARTS OF THE MACHINE WITH DESCRIPTION:

### 5.5.1 Accumulator:

An accumulator is a device which allows the rope to be accumulated in a controlled manner at the time of unwind the section beam on the Long Chain Beamer in order to find out and to repair a broken end. The accumulator is an important component on a Long Chain Beamer, as there is no stop motion device in the re-beamer and the operator observes the yarn sheet whether there is any broken end.

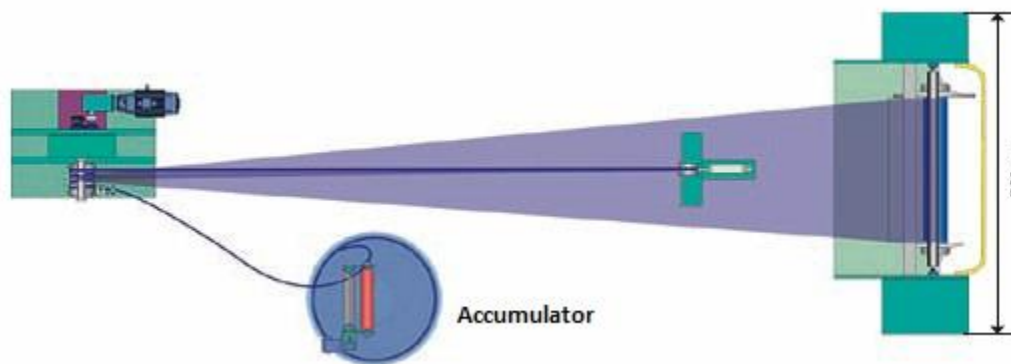


Figure 10: Accumulator in machine

### 5.5.2 Tension Stand:

When the ropes come down from the guiding device, it passes through tensioning Stand rollers. The purpose of the Tension rollers is to establish necessary warp tension to the rope and help in further separation of the ropes before going through a comb. If no tension is applied to the rope, then the rope has a tendency to resist opening up into the sheet form. Ultimately each in the rope will start separating directly at the comb located at the Long Chain Beamer. This may lead to rope damage. The Tension Stand is approximately 4-feet high and consists of two tension drums, each approximately 14-inches in diameter and 14 inches face length. These rolls are fitted one over the other.

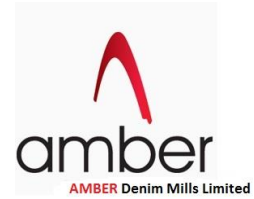


Figure 11: Tension Stand

### 5.5.3 Beater Bar and Comb:

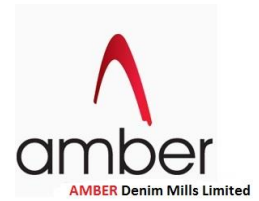
After the Accumulator the rope returns to the Tension Stand. There is a Beater Bar located at the top of the Tension Stand which is round four or five sided in shape. It is at this point where the yarn rope begins to be opened into a yarn sheet. The function of the Beater Bar is to apply sufficient tension, friction to the rope, assisting in the opening or spreading the yarn and to separate the ends without any damage to the yarn. After the Beater Bar the rope passes through a comb located on the Long Chain Beamer, which separates individual yarn ends and keeps them parallel to one another. From the comb, the warp yarns are guided onto a flanged section beam. In the Long Chain Beamer, the section beam is supported and driven by an electric motor. The electric motor may be of either DC motor or AC inverter type drives spindles spindles which support the section beams. The section beam wind the yarn sheet onto it. Generally, the operator runs the machines by pressing a Foot Pedal. As long as the Foot Pedal is depressed, the machines continues to run and whenever the Foot Pedal is released, the machines stops.

### 5.5.4 Stop Motions:

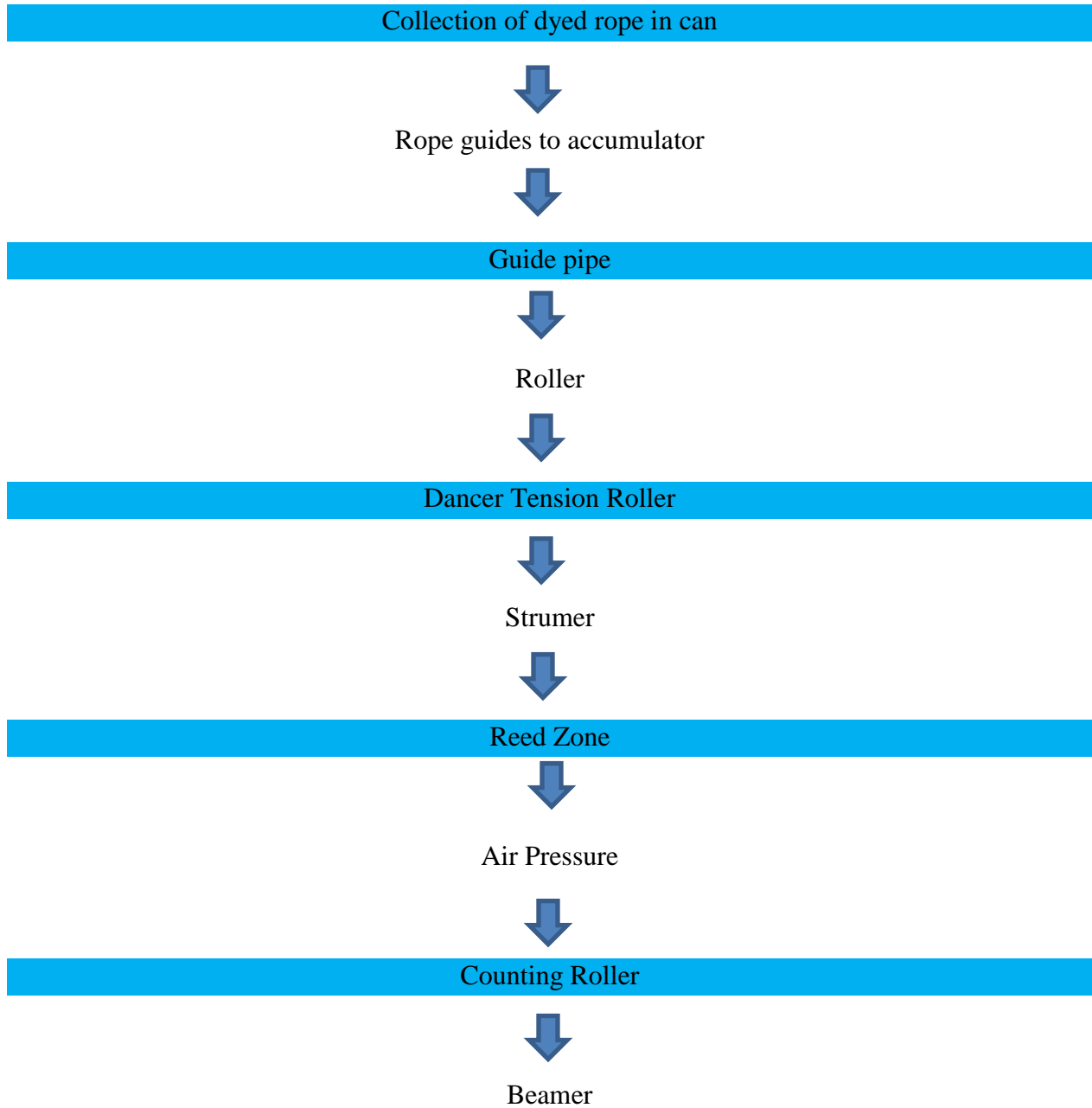
In most of the LCB machines not incorporated with any automatic stop machines. The eyes of the operator work to detect the end breakages. However it depends on the skills of the operators. This manual system of detection of end breakages is not a reliable system of detection of end breakages in any Beaming operations. Some machinery manufacturer incorporated various stop motions in re-beaming process in order to detect the end breakages in LCB.







## 5.6 Process Flow Chart of Long Chain Beamer (LCB):



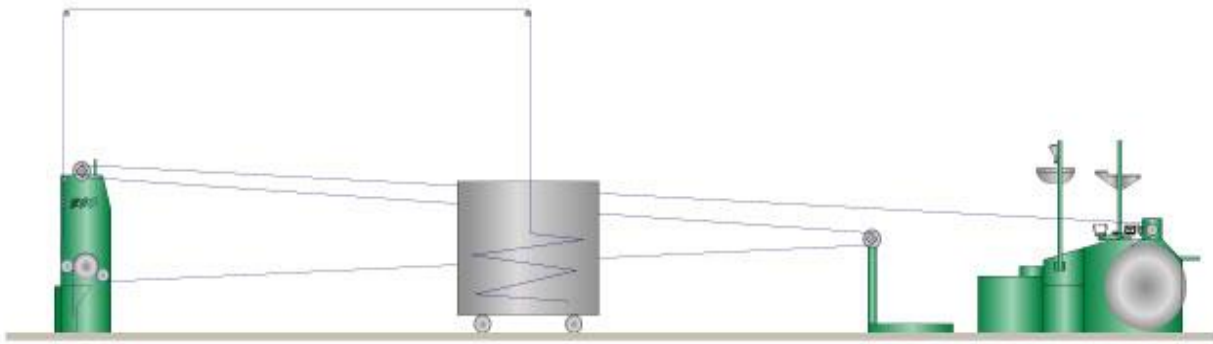


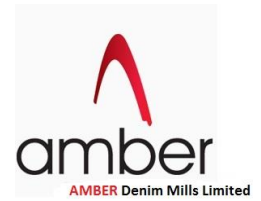
Figure 11: Passage of rope in Morrison LCB Machine (Side view)

### 5.7 Controlling Parts & Parameters:

- ❖ In the machine, tension, speed & other things can be controlled.
- ❖ There is a foot switch & it can be manually on-off operation can done in machine.

### 5.8 Troubleshooting:

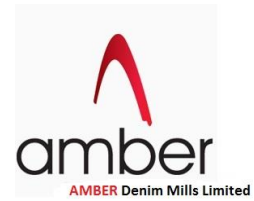
- ❖ If there is breakage formation between the yarns, it can be controlled by knotting with other yarns.
- ❖ If the RH% is high & probability of yarn breakage increase, then it can be controlled by maintaining machine speed & tension.



## Chapter Six

# SIZING





## Sizing Process

### **6.1 SIZING PROCESS:**

The purpose of sizing is to increase the yarn strength through chemically binding with each other. Sizing is the process of giving a protective coating on the warp yarn to minimize yarn breakage during weaving. Sizing is the most important operation in preparing warp yarn for weaving especially with cotton yarn. The smallest error in sizing process may be very harmful. This may increase warp breakage rate on the looms and consequently reduce weaving production and quality. Therefore sizing is termed as the “Heart of Weaving”.

Sizing is the process of applying an adhesive coating on the surface of the yarn. Sizing is applied into the yarn mainly to improve the weave ability of warp yarn by making it more resistant to action of weaving i.e. absorption, friction, tension & flexing. It also maintains good fabric quality by reducing hairiness, weakness & by increasing smoothness, absorbency of yarn. The most other features of the sizing is change of various physical properties. Sizing is applied on to the fibre surface by various process and various recipes according to the requirements. Also the size protective coating prevents the indigo dye from rubbing off during the weaving. Sizing operations also involves multiplication of warp sheet from LCB (long chain beamer) sheets by collecting the Yarn together and making one weavers beam.

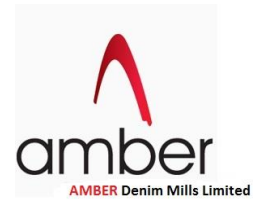
In our “AMBER DENIM MILLS LTD”, there are 3 sizing machine. There are 2 “UKIL MACHINE” and “KARL MAYER MACHINE”.

### **6.2 Objects of Sizing:**

- To improve the weave ability of warp yarn.
- To increase the tensile or breaking strength for cellulose yarn.
- To maintain good quality fabric.
- To reduce hairiness, weakness in the textile materials.
- To increase elasticity of fibres.

### **6.3 Changes in Yarn due to Sizing:**

- Breaking strength: Increase
- Abrasion Resistance: Increase
- Stiffness: Increase
- Elasticity: Increase
- Frictional Resistance: Increase



- Yarn Diameter: Increase
- Extension: Decrease
- Electrostatic Charger: Decrease
- Hairiness: Decrease

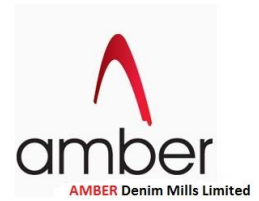
## 6.4 MACHINE SPECIFICATION:

### Ukil Machinery Co. LTD:

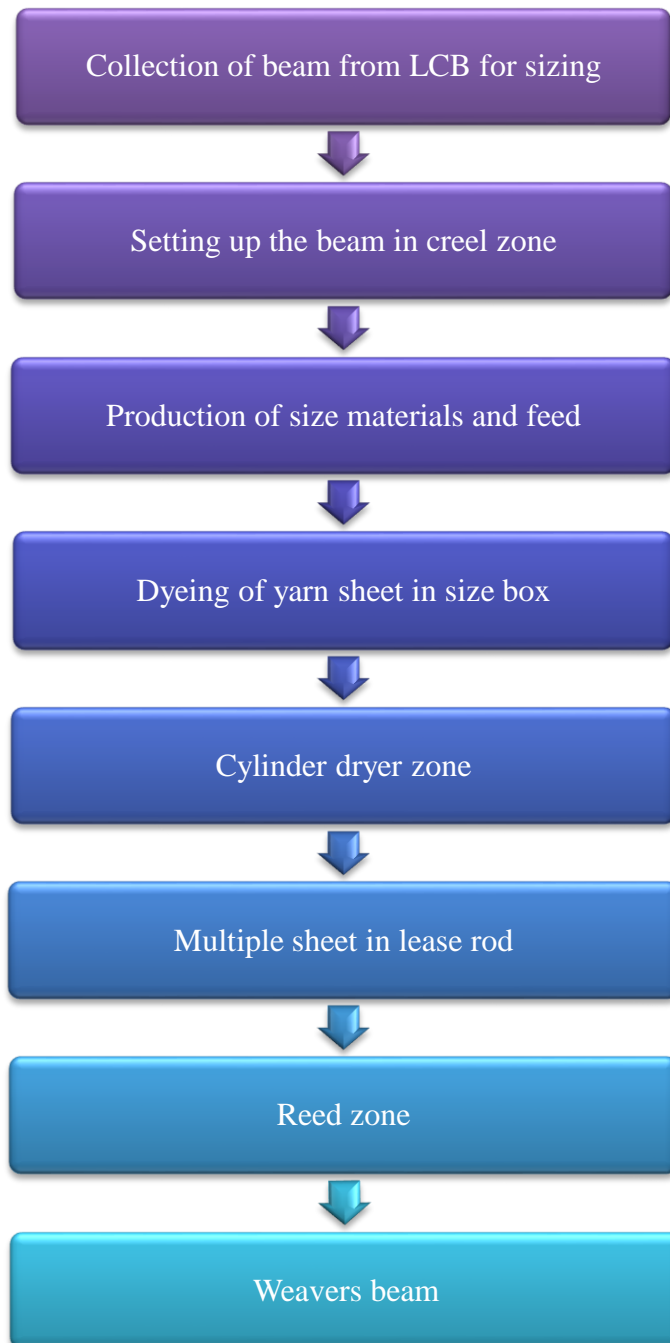
<b>Origin</b>	<b>USA</b>
<b>Model no</b>	<b>GSSM-100 Expert Sizer</b>
<b>Manu. Date</b>	<b>09-2011</b>
<b>S/N</b>	<b>USS-1103</b>
<b>Engineered by</b>	<b>USA Mechatronics LTD.</b>
<b>Creel Capacity</b>	<b>32</b>
<b>Machine speed</b>	<b>(100/75) m/min</b>
<b>Reed No</b>	<b>525</b>
<b>Made In</b>	<b>Korea</b>

### KARL MAYER ROYAL SMR:

<b>Description</b>	<b>Textile Machine</b>
<b>Type</b>	<b>CSB 1/1000</b>
<b>Origin</b>	<b>Germany</b>
<b>Serial No.</b>	<b>115889-3</b>
<b>Const. Year</b>	<b>2014</b>
<b>Made In</b>	<b>Italy</b>
<b>Creel Capacity</b>	<b>36</b>
<b>Machine speed</b>	<b>125 m/min</b>



## 6.5 PROCESS FLOWCHART:



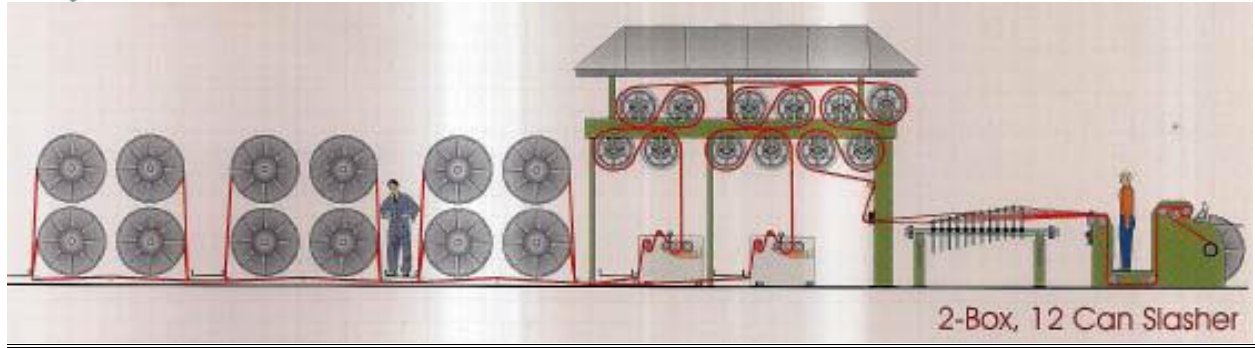
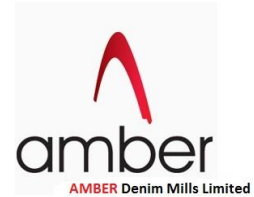


Figure 12: Schematic view of sizing machine



Figure 13: Sizing machine in ADML



## 6.6 MACHINE PARTS & DESCRIPTION:

1. Creel
2. Pre-Beam
3. Feeding r/r
4. Guide roller
5. Tensioner roller
6. Sizing box
7. Immersion roller
8. Sizing roller
9. Squeezing roller
10. Cooking box
11. Steam pipe
12. Drying cylinder
13. Lease rods
14. Reed
15. Nipper roller
16. Warp beam
17. Pressure roller

### Creel Zone:

In the magazine creel, there are two creel sections; one creel in the storage position can be used for loading of re-beamer beam, while the other creel is in running condition. The advantages of the creeling are higher productivity due to saving time in the set change. There are different types of magazine creel available. The most common types are the side-to-side and front-to-back/side-to-side. However magazine creel takes more space. Another creel design is the rotating or carousel creel. In this creel design, two creel sections are tied together and turn on a central pivot point. Rubber wheels are fitted at the four corners of the creel which allow the creel to turn. The back of the creel becomes the front of the creel in the running position.

The creel can be loaded in remote locations, may be near long chain beaming and then pulled on a cushion of air into the position behind the back of a sizing machine.





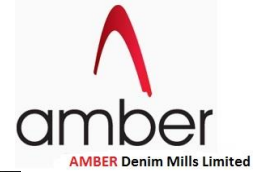


Figure 6.6.1: Magazine creel used in ADML

Back beam unit:

In single end sizing yarns are taken from a creel rather than from a beam. This unit contains 12 carriers from where yarn is supplied. Indirect & direct process of yarn supply is frequently used for spun yarns. In case of indirect method beam creel is used. This beam creel can be arranged in various ways.

Sizing unit:

In this unit a size box is used to apply size to the yarn. The warp sheet is guided through the solution means of the immersion roller & then through the squeeze roller where the yarns are pressed to maintain the required size to up percentage by the yarn. The size box temperature is controlled by flowing steam through pipe. There are two size box in both Ukil machine & Karl mayer machine.

Drying unit:

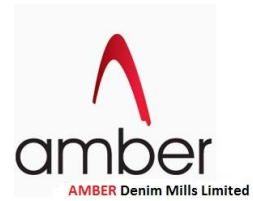
12 heated cylinders consist of drying unit. This unit is required to dry the wet sized yarn rapidly, thoroughly & uniformly by use of steam. A two cylinder dryer is too slow & it is difficult to maintain by it. But a multi-cylinder dryer is a good one to main in such a way that after drying. Yarn contains 6% moisture here. Drying box maximum temperature: 120°C.

1<sup>st</sup> Drying box Temperature: 100°C

2<sup>nd</sup> Drying Box Temperature: 100°C

3<sup>rd</sup> Drying Box Temperature: 95°C





Cooling unit:

In this unit there is cooling fan & a guide roller. The cooling fan supplies cool air which extinguish the yarn temperature & also remove the moisture.

Dividing unit:

In order to prevent adhesion between the yarns, it is necessary to separate each sized end from the others. For this lease rod or breaker rods are used to divide the main warp sheet into different sheet into each single end.

Measuring unit:

This unit consists of colouring bowl which contains easily removable colour. This colour is used for making on sized yarn. Also there is a measuring roller which measures the length of sized warp yarn.

Beaming unit:

Finally the sized warp is wound on weavers beam.

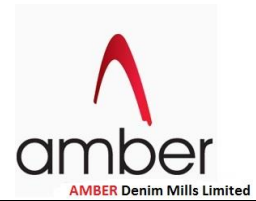
### 6.7 USED CHEMICAL FOR SIZING:

In sizing box there are 2 tanks, where the chemical has been mixed up. One is feed tank and other is dossing tank.

- Tank capacity for UKIL machine: 2000 liter
- Tank capacity for KARL MAYER machine : 1300 liter
- Size box capacity for UKIL machine : 200 liter
- Size box capacity for KARL MAYER machine : 200 liter

In our “AMBER DENIM MILLS LTD” chemicals used for sizing are given below:

Name	Chemical Type	Moisture Contents	Origin	Solid
Emsize ES	Potato starch modified	11%-13%	Germany	86%
Emsize T20	Starch derivatives	20%	Thailand	80%



Bentex B-120	Modified starch	22%	Thailand	80%
Bentex K-2000	Modified starch	16%	Thailand	85%
CMS-60	Highly modified starch	13%	Germany	95%
Bentex B-99	Highly modified starch	15%	Thailand	90%
Bentex B-60	Softener	37%	Thailand	22%
Textile Wax	Softener	35%	Germany	25%
Size PCB PD	Binder	60%	Pakistan	35%-40%
Unsize wax	Binder	55%	Bangladesh	40%
Native Topica starch	Starch	10%		88%

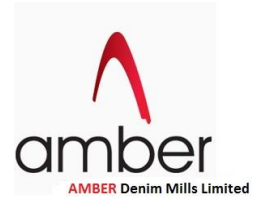
## 6.8 FUNCTION OF THE CHEMICAL:

### 6.8.1 Starch:

Starch is the main sizing ingredients. They coat the warp yarn with a film & impart smoothness by binding the projecting fibres to the yarn surface. The viscosity of the size solution is controlled by the amount of starch, the recipe, degree of mechanical mixing, temperature & time of boiling.e.g. Potato, CMS (Carboxyl Methylated Starch), PVA (Polyvinyl Alcohol).

#### Function:

- ❖ To improve the strength
- ❖ To increase smoothness
- ❖ To increase elasticity
- ❖ To increase stiffness
- ❖ To impart adhesion



### **6.8.2 Binder:**

These materials penetrate into the yarn & contribute in increasing yarn strength. These materials can be used as an independent gum & substitute of starch products. e.g. Polyacrylamide, Polyacrylonitrile etc.

### **6.8.3 Softener:**

The hard fragile film is softened by addition of softener. They increase flexibility of yarn after sizing; e.g. Tallow, Soap, Japanese wax, Modified wax, Artificial wax.

### **6.8.4 Anti-septic agent or Anti mildew agent:**

The size recipe consist starch which the protein substances in the favorable medium for the development of the micro-organism (Fungi, Mouldetc). The sized warp or grey cloth is stored for long time; the anti-septic agent is used to prevent the growth of micro- organism in the grey cloth.

Function:

- ❖ To prevent mildew formation
- ❖ To prevent size material for a longtime
- ❖ To protect yarn from bacteria or fungi.

### **6.8.5 Weighting agent:**

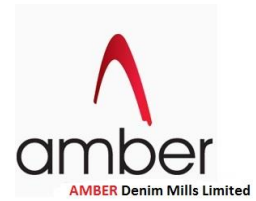
These agents are used to increase the weight of the fabric. The fabrics are to be sold at grey stage or require the special type of finishing to get fuller appearance are sized with the weighting agent.

### **6.8.6 Antifoaming Agents:**

The substrates which prevent the foam formation is called antifoaming agent. Example: Pyridine, Benzene etc.

Function:

- ❖ To prevent foam formation
- ❖ To give uniform size pickup



## 6.9 Recipe & Testing:

Before mixing the size material in the size box with ends, it is needed to make the proper recipe by countwise and also done some test whether it is proper size liquor or not.

### 6.9.1 RECIPE for sizing:

Set no : 1616-449p+ 450p

Total Ends : 6100

E/Beam : 381

Ratio : 6:10

Colour : Bottoming

Count : R/SI + Rc

Set Length : 6950\*12 meter

SI NO	Water (litre)	K-2000 (kg)	B-120 (kg)	E-850 (kg)	PVA (kg)	B-60 (kg)	Ref %	Viscosity	Total volume	Temperature
01	1000	36	84	09	02	10	8%	18	1250	92°C
02	1000	36	84	09	02	10	8%	19	1250	92°C
03	1000	36	84	09	02	10	8%	18	1250	92°C
04	1000	10.8	25.2	2.7	0.6	03	8%	19	400	92°C

### 6.9.2 TESTING:

After mixing, the materials together the mixing liquor has to test that it is well mixture or not. After mixing we have done 2 type of test. They are:

- (1) **Viscosity Test:** After mixing, viscosity test has been done. Mixer is proper denser or not, it is tested by viscosity test. If the test is done between (13-23)sec then the liquor is standard.
- (2) **Reflectometer:** Another test is done with the reflectometer.

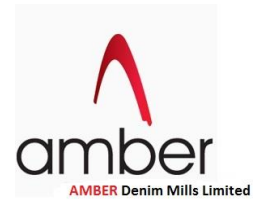




Figure 13: Industrial Reflectometer

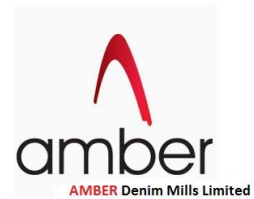
### 6.10 Controlling Parameters of Sizing:

- ❖ Viscosity of the sizing solution
- ❖ Speed of sizing machine
- ❖ Volume of the size box (both quantity and size level)
- ❖ Concentration of the size mixture
- ❖ Condition of squeeze rollers
- ❖ Temperature of dryer
- ❖ Controlling of yarn moisture
- ❖ Controlling of lease.



## Chapter seven

# WEAVING



## Weaving

### **7.1 Weaving definition:**

Weaving is called the heart of denim. The process of producing a fabric by interlacement of warp ends and weft threads is known as weaving. The machine used for weaving is known as weaving machine or loom machine. Weaving is an art that has been practiced for thousands of years. The earliest application of weaving dates back to the Egyptian civilization. Over the years, both the process as well as the machine has undergone phenomenal changes. As of today, there is a wide range of looms being used, right from the simplest handloom to the most sophisticated loom.

### **7.2 DENIM WEAVING:**

Denim is a traditionally woven fabric with what is known as a twill weave fabric. This is simply a weaving pattern that produces parallel diagonal ribs. The weaving process interlaces the warp, which are the length-wise indigo dyed yarn and the filling, which are the natural-colored cross-wise yarn. The warp thread is in the form of sheet. In denim, the warp-faced twill pattern is passing the weft yarn over the warp yarn one and under two (2/1), or over one and under three warp (3/1) yarns. Because there are fewer lacings in twills than in plain weaves, the yarns are freer to move when being worn resulting in a fabric that is both flexible and resilient. The weft thread is inserted between two layers of warp sheets by means of a suitable carrier, such as Shuttle, Projectile, Rapier, and Air current etc. The selection of carrier depends upon the type of weaving machinery used. The two different technologies available for weaving machines are - Conventional Shuttle Weaving System which is done by Ordinary Looms or Automatic Looms; and the Shuttle less Weaving System which is done by Airjet, Waterjet, Rapier, or a Projectile weaving machine.

The yarns used in making denim which have a very high twist, a process which gives the yarn much greater resistance both to tensile stress and to abrasion.

### **7.3 Basic Weave Designs:**

- Plain weave
- Twill weave
  - Herringbone twill
  - Broken Twill
  - Zigzag Twill

#### **7.3.1 Plain weave:**

Plain weave is the simplest weave formation of all weaves. It has one-over one-under interlacing for both warp and weft yarns, therefore the plain weave formula repeats on two warp and two weft yarns. Plain weave requires only two harnesses frame. In Denim manufacturing this weave is called Chambray. There is a plain weave is shown in figure.





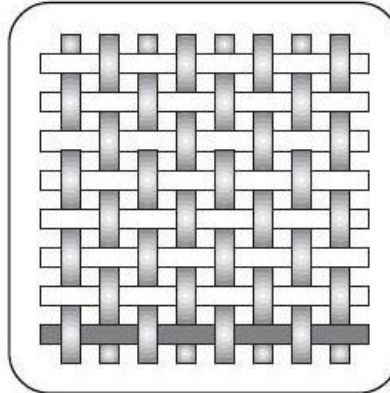


Figure : Plain Weave

### 7.3.2 Twill Weave:

Twill Weave is produced in a stepwise progression of the warp yarn interlacing pattern. The interlacing pattern of each warp yarn starts on a different filling/weft yarn and follows the same formula. These results in the appearance of a diagonal line called twill line in the fabric, which is then characteristic of this design. Depending on the direction of the twill line, the twill weaves are called right-hand twill (RHT) or left-hand twills (LHT). The sum of the digits in the formula determines the unit cell of the design, which also gives the minimum number of harnesses, requires weaving the design; at least three harnesses are required for a twill weave. Common twill, Step twill, herringbone twill and broken twill are the different variations of the twill weave.

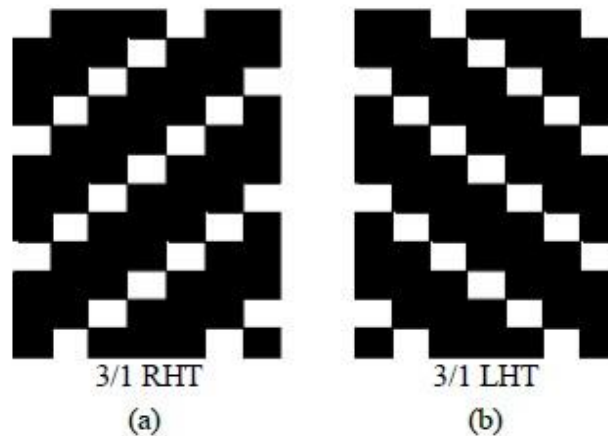
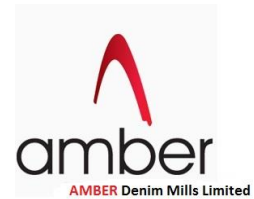


Figure 7.3.2: 3/1 Right hand twill, 3/1 Left Hand twill



## 7.4 Classification of Modern Weaving Machines:

Modern Weaving machines are classified according to their filling insertion mechanism.

The classification is as follows:

- Rapier
- Projectile
- Air-Jet
- Water-Jet

### 7.4.1 Air-Jet loom:

Air jet loom is one kind of shuttle less loom. Normally, air jet loom uses a jet of air for propelling the filling yarn through the weaving shed. It requires uniform filling yarn. They are suitable use with medium weight yarns then very light and very heavy yarn. Air jet loom is one of the two types of fluid jet looms where another one is water jet loom.

Yarn is drawn from a filling supply package by the filling feeder and each pick is measured for the filling insertion by means of a stopper. Upon release of the filling yarn by the stopper, the filling is fed into the reed tunnel via tandem and main nozzles, which provide the acceleration. The relay nozzles provide the high air velocity across the weave shed. Profiled reed provides guidance for the air and separates the filling yarn from the warp yarn.

#### 7.4.1.1 Advantages of Air Jet Loom:

- In case of air jet loom, noise level is lower than rapier loom.
- Less power consumption in air jet loom
- Normally, standard width of air jet loom is 190cm.
- Weft insertion performance is too much here (normally 600 rpm).
- It consumes very low power.



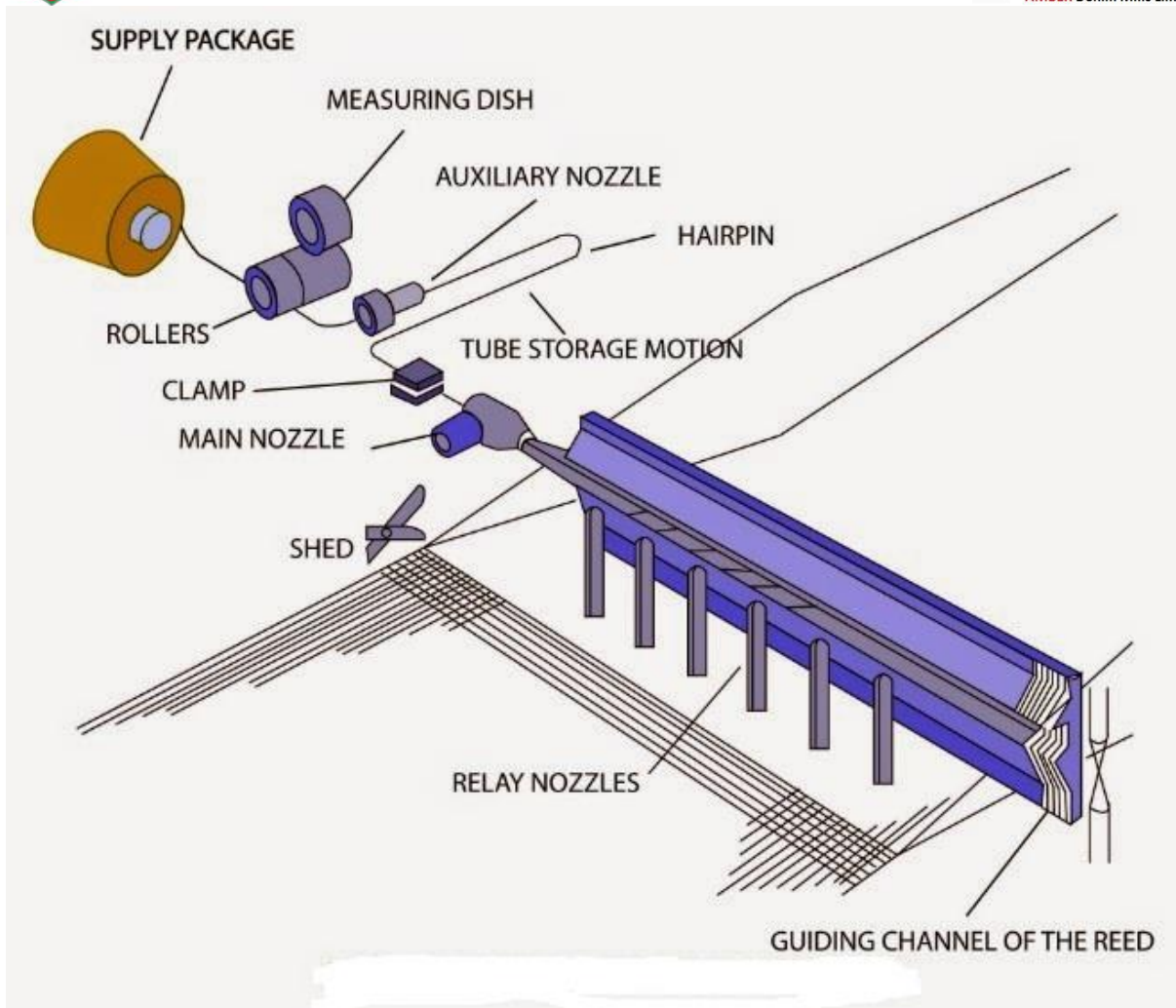


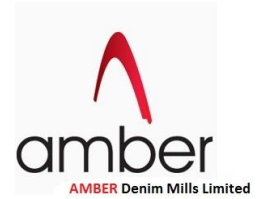
Fig 14: Operation of Air Jet Loom

### 7.4.2 Rapier Loom:

In Rapier weaving, a flexible or rigid solid element, called rapier, is used to insert the filling yarn across the shed. The rapier head picks up the filling yarn and carries it through the shed. After reaching the destination, the rapier head returns empty to pick up the next filling yarn, which completes the cycle. A rapier performs a reciprocating motion.

Rapier weaving machines can be of two types:

- Single Rapier Machines:



A single, rigid rapier is used in these machines. The rigid rapier is a metal or composite bar usually with a circular cross section. The rapier enters the shed from one side, picks up the tip of the filling yarn on the other side and passes it across the loom width while retracting.

Therefore, a single rapier carries the yarn in one way only and half of the rapier movement is wasted. Also there is no yarn transfer since there is only one rapier. The single rapier's length is equal to the width of the loom.

➤ **Double Rapier Machines:**

Two rapiers are used in these machines. One rapier, called the giver, takes the filling yarn from the yarn accumulator on one side of the loom, brings it to the center of the machine and transfers it to the second rapier which is called the taker. The taker retards and brings the filling yarn to the other side. Similar to the single rapier machines, only half of the rapier movements are used for filling insertion.

## **7.5 Basic Motions:**

In order to interlace the warp & weft yarns & produces fabric, the following motions are necessary which are given below:

- Primary Motion
- Secondary Motion
- Tertiary Motion

### **7.5.1 Primary Motion:**

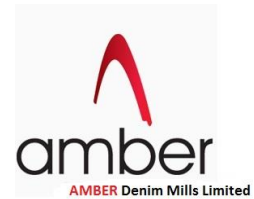
It is considered as the fundamental or essential motion for weaving operation. Without this motion weaving operation cannot operate. There are three types of primary motion which has different sub division. These are:

#### **7.5.1.1 Shedding mechanism:**

In weaving, the shed is the temporary separation between upper and lower warp yarns through which the weft is inserted. The shed is created to make it easy for interlacing the weft into the warp and thus create woven fabric. Most types of looms have some sort of device which separates some of the warp threads from the others. This separation is called the shed, and allows for a shuttle carrying the weft thread to move through the shed perpendicular to the warp threads. Which threads are raised and which are lowered are changed after each pass of the shuttle. In Amber Denim Mills Limited, two types of shedding mechanism have been used. These are



### ❖ Cam Shedding:



The purpose of the cam is to control the motion of harness frames which divides the warp yarn and the weave pattern. Possible weave patterns of fabric are 1/1, 2/1, 3/1 and 4/1 for denim fabric. The cam acquires special curved shape. Different cam setting can be used for different weave pattern. It is the required condition that the machine revolution should match with gear system gear ratio is adjusted according to the weave pattern. Generally in Cam shedding, maximum 8 harness frames is used for weaving application. There are two main shedding components:

1. Heald frame
2. Cam

### ❖ Dobby Shedding:

The dobbie is a shedding mechanism device which is placed on the top of a loom in order to produce figure or fancy patterns by using a large number of harness frames than the capacity of cam shedding. In Dobby shedding, maximum 16 harness frame is used.

There are two main shedding components:

1. Heald frame
2. Cam

#### **7.5.1.2 Picking Mechanism:**

Weft yarn passes from cone package from one selvedge of the fabric to the other through the shed by means of a shuttle, a projectile, a rapier, a needle, an air-jet or a water-jet. The inserted weft thread is known as “pick”.

The main Objective of picking is to propel weft carrying element (shuttle, air inject or rapier) or the weft yarn along the correct trajectory maintaining requisite velocity through the shed in order to provide lateral sets of yarns in the fabric.

The purpose of this stand is to hold the cones. The main components of cone stand are:

1. Cone holder
2. Disc Tensioner
3. Filling Cutter
4. Nozzles

### 7.5.1.3 Beating up Mechanism:

Beat up mechanism beats or pushes the inserted weft yarn through the profile reed to make the fabric.

The objectives of beat-up motion are as follows:

- ❖ To ensure uniform pick spacing in the fabric
- ❖ To push the newly inserted pick up to the cloth fell.

Main components used for beat up mechanism is Profile reed.

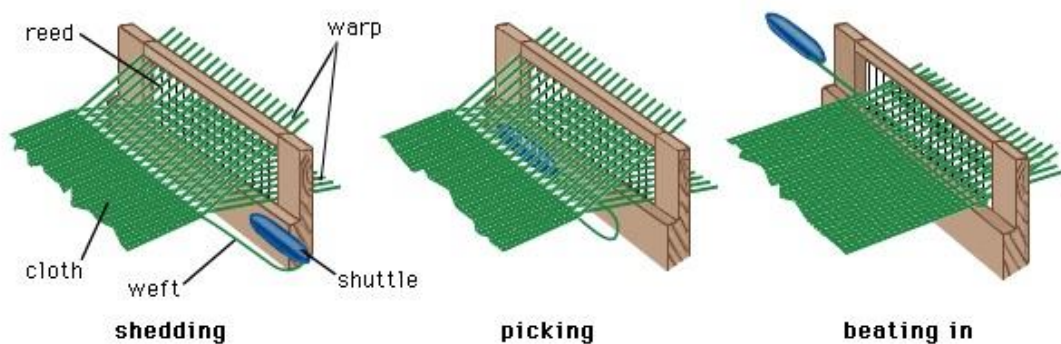


Figure 15: Primary motion diagram

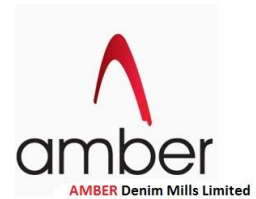
## 7.6 Secondary Motion:

### 7.6.1 Take Up Motion:

The objective of take-up is to draw forward the woven cloth as a new pick is inserted in order to maintain the line of fabric formation and pick spacing constant. The main part of the mechanism is the take up rollers, which draws the cloth at the regular rate, and the number of picks per inch decides this rate. Take-up motion is classified as negative and positive take-up. Another way of classifying it is intermittent and continuous take-up. On the other hand, continuous take-up operates continuously to draw the woven fabric.

### 7.6.2 Let Off Motion:

The objective of let-off motion is to maintain the free length of warp within specified limits and to control the warp tension by means of feeding the warp at a correct rate to the weaving zone.



### 7.7 Tertiary Motions:

Auxiliary motions are those which are added into the machine for getting better quality of woven fabric & maintain a higher productivity. Auxiliary motions are important motion but they are not essential. For getting better quality, this motion is set automatically or manually. Some auxiliary motions are listed below:

1. Accumulator stop motion
2. Balloon Breaker
3. Warp Stop motion
4. Weft stop motion
5. Temples

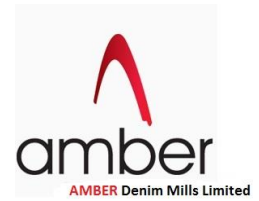
### 7.8 Weaving in Amber Denim Mills Limited:

In amber denim mills limited, there are total 180 weaving machine. From those 176 are air-jet loom machine & 4 machine are rapier loom machine. The department is working under a very good supervision of Mr. Emdad Hossain who is weaving manager and Mr. Hamim who is assistant manager. They are very much dedicated to their work. They are working with all their technical, management hard work. Like some other departments weaving department is running 24 hours a day and meeting the sales requirements.

Weaving department is playing a leading role in denim manufacturing at of denim at Amber Denim Mills Limited.



Figure 7.5: Weaving machine at ADML



## 7.9 Machine specification:

### Weaving Machine:

Machine Name	Picanol Nv
<b>Origin</b>	BELGIE (BELGIUM)
<b>Model</b>	OMP800-2-P
<b>Speed</b>	850 rpm
<b>Reed</b>	Profile Reed
<b>Shedding</b>	Two types of shedding used Cam shedding Dobby Sheeding
<b>Air Pressure Required</b>	9-10 bar
<b>Total Relay valve</b>	14
<b>Number if Heald Shaft</b>	Cam: 6-8 (generally used 3-4) Dobby: 16-12 (generally used 9-12)
<b>Number of Cutter</b>	2
<b>Let off Motion</b>	Electrical
<b>Take of Motion</b>	Electrical

### Others machine specification:

<b>Dobby Box Name</b>	<b>STABULI FAVERCES SCA</b>
<b>Origin</b>	France
<b>Model No:</b>	74210 FAVERCES
<b>Electrical Panel Name</b>	Picanol NV
<b>Origin</b>	BELGIUM
<b>Catch Cot Bobbin</b>	BRANDT MASCHINEN ANCHEN- GERMANY
<b>Origin</b>	GERMANY



## 7.10 Process before weaving:

### 7.10.1 Knotting machine (Warp Tying-In):

When fabric of a particular type is being mass-produced, the new warp beams will be identical with the inserted beams on the looms. Therefore, it is required that every end on the new beam is tied to its corresponding end on the old beam, the drawing-in process can be omitted. Tying-in may be done by means of a small portable machine on the loom or as a separate operation away from the loom.



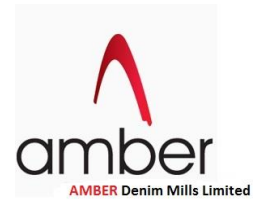
Figure 7.10.1: STAUBLI warp tying in machine used in ADML

#### 7.10.1.1 Machine parts:

1. Yarn pipe
2. Pulley plug
3. Stand pipe
4. Comber
5. Clip
6. Steel Brush etc.

#### 7.10.1.2 Setting of Needle according to count:

28 N (Needle)	9Ne, 10 Ne
25 N (Needle)	10 Ne, 12Ne
32 N (Needle)	7 Ne, 8Ne, 9Ne
14 N (Needle)	16 Ne, 18 Ne, 20 Ne, 30 Ne
16 N (Needle)	14 Ne, 16 Ne, 20 Ne, 30 Ne
22 N (Needle)	12 Ne
36 N (Needle)	6 Ne, 7 Ne
18 N (Needle)	12 e, 14 Ne



### 7.10.2 Catch Cot Bobbin:

It is used for winding the weft cone package at desired length.

### 7.10.3 Leno Bobbin:

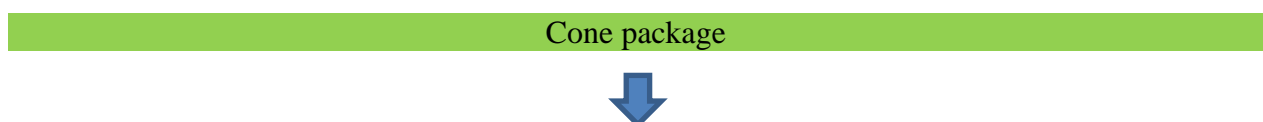
Selvedge thread has been wind in lino bobbin machine.

## 7.11 Process Flow Chart of Air-jet Weaving Machine:

### For warp yarn Insertion



### For weft yarn Insertion



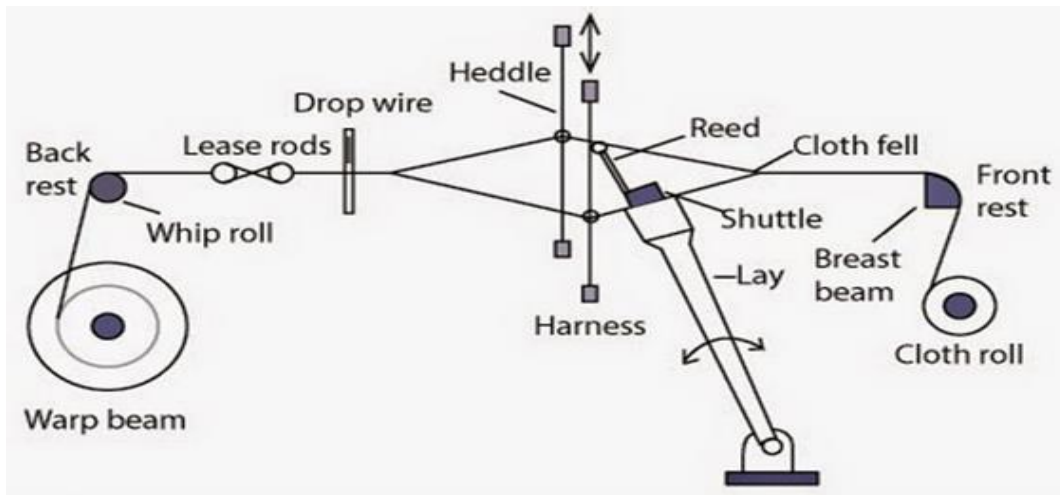
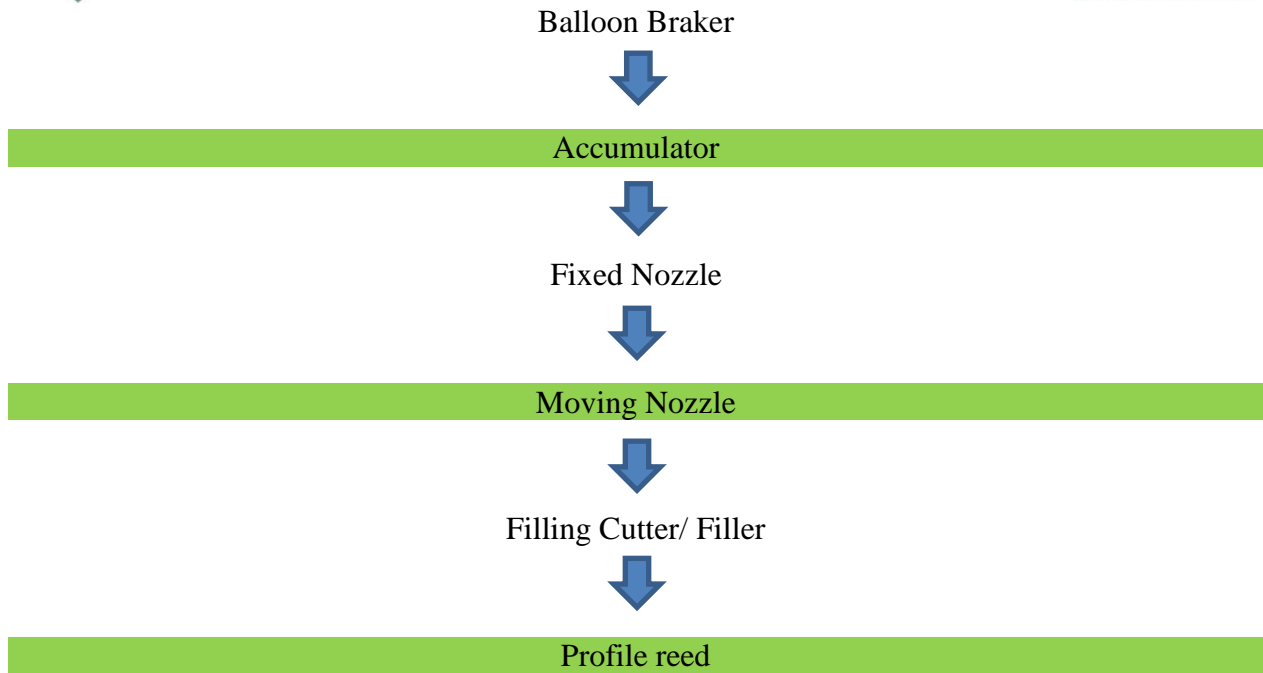


Figure 16: warp yarn insertion diagram

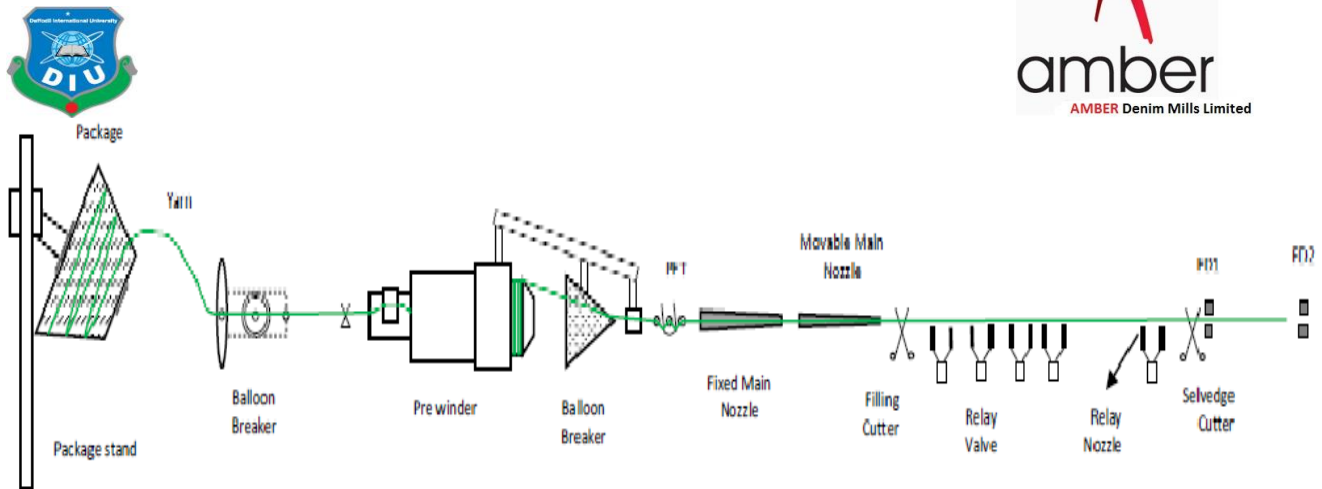


Figure 17: Weft yarn Insertion Diagram

## 7.12 Main parts of weaving Machine:

In AMBER Denim Mills Limited, Air-jet weaving machine has been used for weaving operation. Here we can divide the machine parts into two major parts. These are:

- Warp main Parts
- Weft main Parts

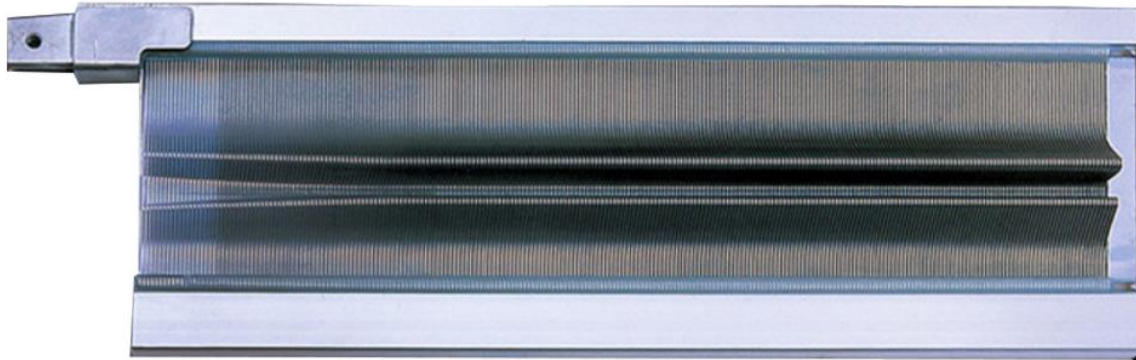
### 7.12.1 Warp Parts:

- **Weavers Beam:** Beam from sizing machine has set up for weaving operation. Here warp yarn is set & by let off motion, warp yarns unwound.
- **Tension Roller:**  
Warp yarn is passed through tension roller. Tension roller is used to give proper tension of warp yarns.
- **Dopper Zone:**  
After tension roller, the warp yarn is passed inside the dopper zone. From dopper zone, warp yarns are passed through heald shaft or harness frame. Here individual yarn is passed through individual dopper eye.
- **Heald shaft/ Frame:**  
A heald shaft consists of a wooden or metal frame carrying heald wires. By the help of shedding mechanism that is previously set by the cam & set up the cam according to fabric design, heald shaft is passed the warp yarns through profile reed. Here heald frame carry heald wires & single warp yarn passes into single heald wires. Here primary motion that is shedding occurs.

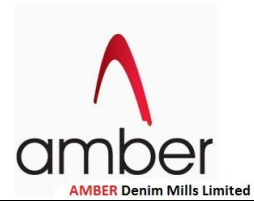


Figure 17: Heald Frames

- Profile Reed:** Profile reed is one of the main parts of the machine where beating mechanism is occurred. Warp yarns from heald frame is passed through profile reed & by beat-up mechanism, profile reed beats the weft yarn according to the design. Before the insertion of warp yarn through reed, denting plan is done. In AMBER DENIM MILLS LIMITED, there is a reed count setting according to the EPI of fabric.



EPI	REED
55	1085/2
60	590/4, 1190/2
66	652/4
71	698/4, 931/3



75	590/5, 739/4, 985/3
80	787/4
83	1085/3, 652/5
91	1190/3
99	985/4, 787/5
105	698/6
110	1085/4
120	1190/4

This reed setting according to count is calculated by Dent per meter (DM).

- Pressure roller: Made fabric from reed zone are passed through pressure roller. It helps to maintain the uniform pressure.
- Sand roller: From pressure roller, fabric is guided through sand roller to maintain the guide of fabric.
- Batcher roller: Fabric roll is set in between of two batcher rollers. By the forward & backward motion, batcher roller helps to winding the fabric in fabric roll. Here take up mechanism works.

### 7.12.2 Weft Parts:

- **Cone Stand:** Cone package of weft yarn has been set in cone stand to deliver the yarn for weft yarn insertion.
- **Tensioner:** Weft yarn from cone package is guided through tensioner to maintain proper tension of yarn.
- **Weft Brake sensor:** It is an electronic brake sensor. It detects whether there is any weft yarn breakage between the cone stand to accumulator.
- **Accumulator:**  
Accumulator is one of the main parts for weft yarn insertion operation. Yarn from weft brake sensor is passed to accumulator. Here an electromagnetic stopper has been set up. If there are any breakage of yarn in the machine, stopper signals & stop the machine. Also here weft yarn is wound & its function is to release the weft yarn insertion & after required length of insertion, it stops the insertion.

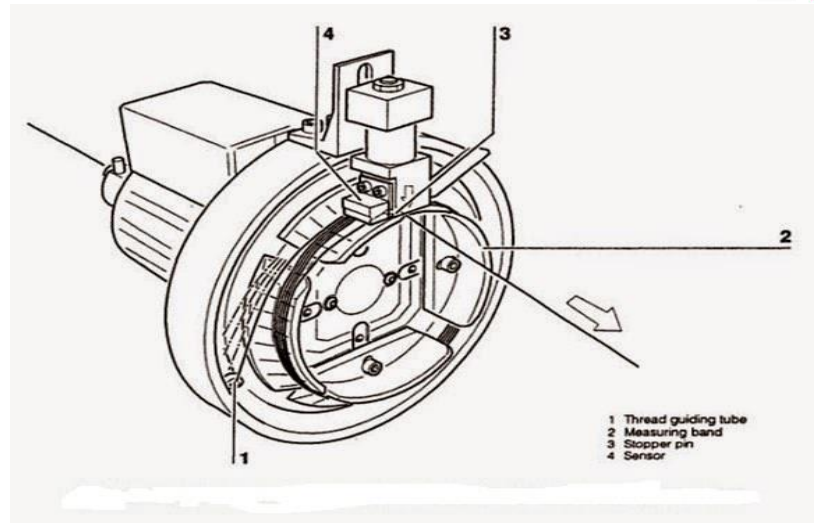


Figure 18: Accumulator

- **Ballon Braker:** It is set in front of accumulator. It is used for guided the yarn through nozzle.
- **Fixed Nozzle:** Yarn from ballon braker is passed through fixed nozzle. Here formation of air-jet from compressed air with required velocity and acceleration occurs & projects the yarn in the proper direction.
- **Moving Nozzle:** It is set in front of the fixed nozzle. Yarn from fixed nozzle is guided here.
- **Relay/ Sub Nozzle:** It is guided under the reed. Relay nozzles are arranged as the entire length of the reed, the relay nozzles assists the movable main nozzle in blowing the pick through the reed guiding channel. These relay nozzles are divided up into groups, in that each group of nozzle is served independently by a relay nozzle valve. These valves are driven such that the rate of insertion is correct and that yarn flow is uniform. It also gives proper air pressure to straighten the fabric.
- **Filling Cutter:** This device is fitted on the region between the moving nozzle & the reed picking side. When the weft yarn is inserted in the reed into required diameter, filler cut the yarn. Filling cutter has done cutting after every pick.
- **Selvedge Cutter:** Selvedge cutter cut in the selvedge region of fabric according to require diameter.
- **Weft Detector:** Its function is to check the arrival of weft yarn after each pick at receiving side.

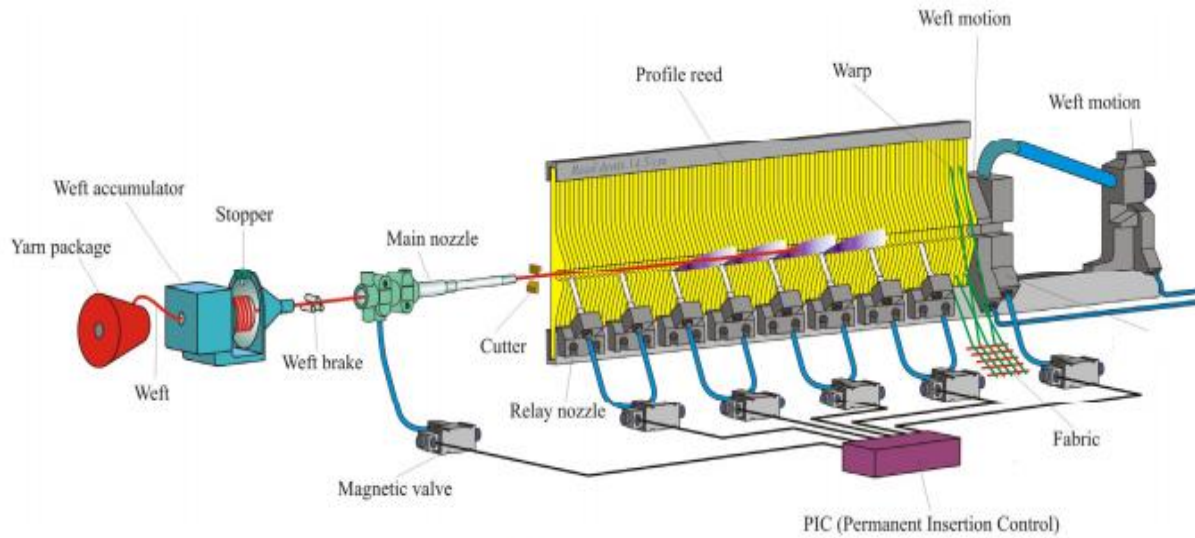


Figure 19: Weft yarn insertion diagram

### 7.13 Selvedge:

Selvedge is an important role for further processing of a fabric. Air-jet weaving machine can be equipped with various types of selvedge formation devices. Several machinery manufacturers incorporate different types of selvedge formation devices as per requirement of the end products.

Leno selvedge is a type of selvedge that is use in weaving operation at Amber Denim Mills Limited.

Leno bobbin is used to make leno selvedge. These selvedges are obtained by binding the wefts with strong additional threads working in gauze weave and by eliminating through cutting the protruding weft ends.

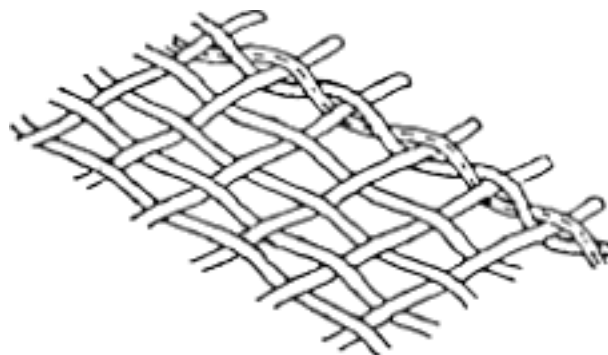
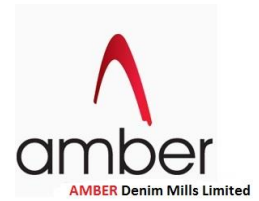


Figure 19: Leno Selvedge





The leno gauze system is optimally suited for heavy fabrics, blankets, wall coverings. Fig. illustrates the operation scheme of the device proposed by a manufacturer, in which device two complete leno gauze mechanisms work in combination. A leno device produces the fabric selvedge, while the other device forms the auxiliary selvedge.

## 7.14 Calculation:

Problem No: 01

Given that,

Number of EPI = 66

Weave: 3/1 RHT

Repeat: 4 ends

Find required reed number?

Find out required reed of Dent per meter?

Solution:

$$\begin{aligned}\text{Dent per meter} &= (66/4) \times 39.37 \\ &= 652 \text{ DM}\end{aligned}$$

Answer: Reed Number 652 DM

Problem: 02

Given,

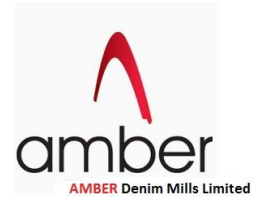
Actual Production = 188773 pick

Calculated Production = 192000 pick

Find out efficiency?

**Solution:**

We know, Efficiency = (Actual Production/Calculated Production) x 100 %



$$\begin{aligned} &= (188773/192000) \times 100 \% \\ &= 98.32 \% \end{aligned}$$

Answer: Efficiency = 98.32 %

### Problem: 03

Given,

Fabric construction = (9 x 9/ 66 x 47) x 65”

Weave = 3/1

R.P.M = 600

Efficiency = 80 %

Find out production per hour in yards?

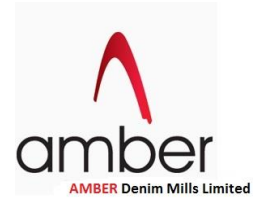
**Solution:**

We know production/hour= (rpm x time x efficiency)/ (PPI × 36)

$$= (600 \times 60 \times .80)/ (47 \times 36)$$

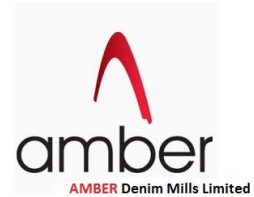
$$= 15.64 \text{ yds. /hour}$$

Answer: Production Per hour per loom = 15.64 yds. /hour



## Chapter Eight

# Finishing



## Finishing

### 8.1 Finishing process:

Finishing is the last manufacturing step in the production of textile fabrics. Finishing is the operation where the final fabric properties are developed. It is also used for improving the appearance or usefulness of fabrics.

Finish can be either chemicals that change the fabric's aesthetic and or physical properties or changes in texture or surface characteristics brought about by physically manipulating the fabric with mechanical devices. It can also be a combination of the two.

### 8.2 Denim Finishing:

Finishing of grey denim fabric normally carried out after weaving. It takes an important role in fabric properties, appearance, softness and residual fabric shrinkage. The finishing of denim fabric is carried out for several purposes. Finishing of denim fabric can be varied according to the specific requirement of customer.

Another fashion trend of denim finishing is soft or washed down denim in place of stiff and harsh denim. To achieve the soft feel in finished denim fabric, the fabric is subject to a desizing and washing processes.

### 8.3 Objects of fabric Finishing:

- To increase the attractiveness of fabric.
- To ensure better service ability.
- To increase the fineness and to ensure smoothness.
- To ensure the softness & hand feel properties of the fabric.
- To free from hairiness of the fabric.

### 8.4 Types of fabric finishing:

There are mainly two types of fabric finishing. These are:

#### ❖ **Mechanical finish:**

Finishes that is performed by machine by not using chemical.

Example: heat set, moisture content, stretching, singeing

#### ❖ **Chemical Finish:**

The finishing process which is performed by application of chemicals which reacts with fibers is termed as chemical finishing.

Example: Waterproof, water repellent, Flame resistant, Antistatic, Stain and soil resistant, Mercerization is some examples of chemical finishing.

### 8.5 Finishing section of AMBER Denim Mills Limited:

Amber Denim Mills Limited has a finishing department is a well-established modern section with a suitable range of the finishing processes required for denim fabric. Proper finishing for denim manufacturing process is necessary otherwise the fabric will be rejected by the buyer. In case of denim mainly controlling of the shrinkage, skewness, width required & chemical finish of the fabric is done. Besides, finishing process finishing section of ADML have to do a lot of others job like fabric storing, inspection, sample processing etc. So a finishing section in a denim industry plays a vital role.

### 8.6 Finishing Machine in ADML:

There are 3 types of finishing machine that is used for fabric finishing in ADML. These are:

1. Sanforizing finishing machine.
2. Clip chain Mercerizing finishing machine.
3. Stenter machine.

The following types of finishes are applied to the denim fabric at Amber Denim Mills Limited.

- Singeing
- Width control
- Shrinkage control
- Skew control
- Sanforizing
- Calendering
- Desizing
- Mercerizing

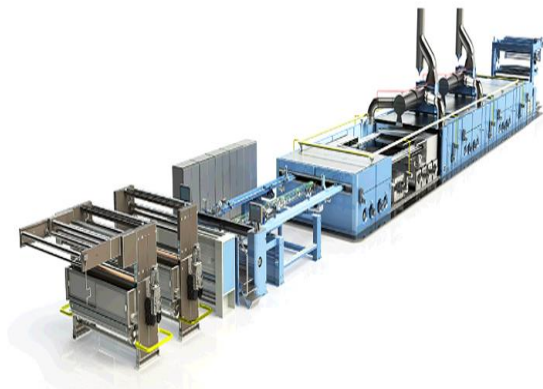
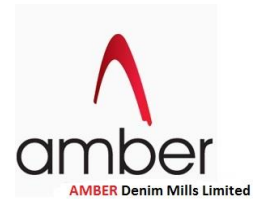


Figure 8.6: Finishing Machine used in ADML (Sanforizing & stenter)



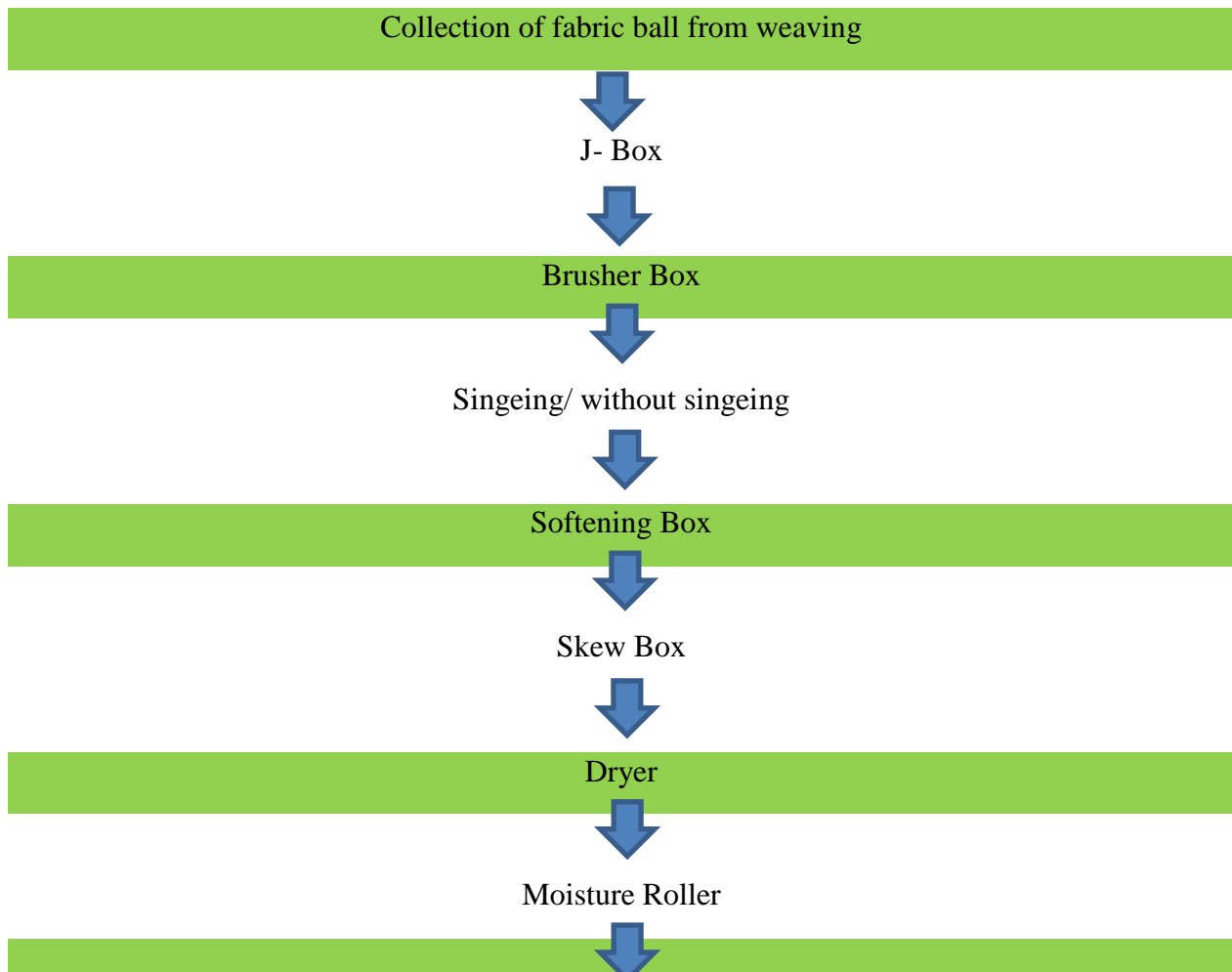
## 8.7 Finishing Process in Amber Denim Mills Limited:

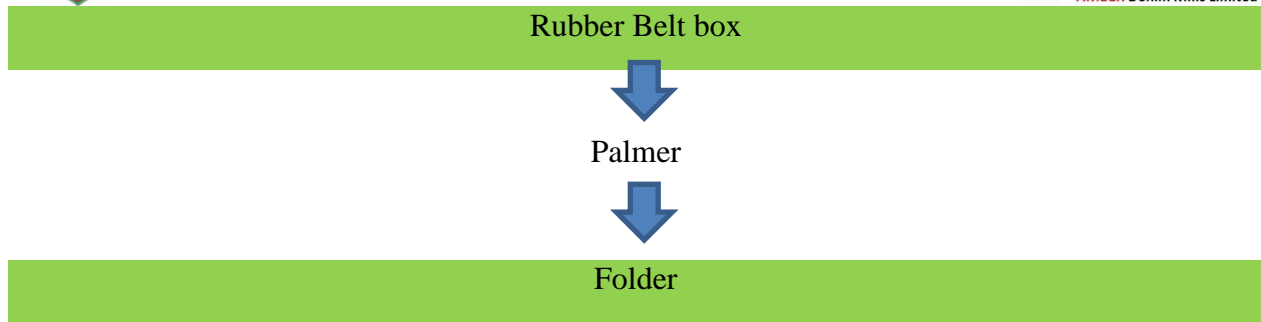
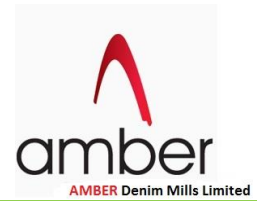
There are five types of finishing process done in ADML according to buyers requirement. These are:

- Normal Finish (NF)
- Soft Finish
- Flat Finish
- Stenter Finish
- Soft finish stenter
- 

## 8.8 Process sequence of different finishing process:

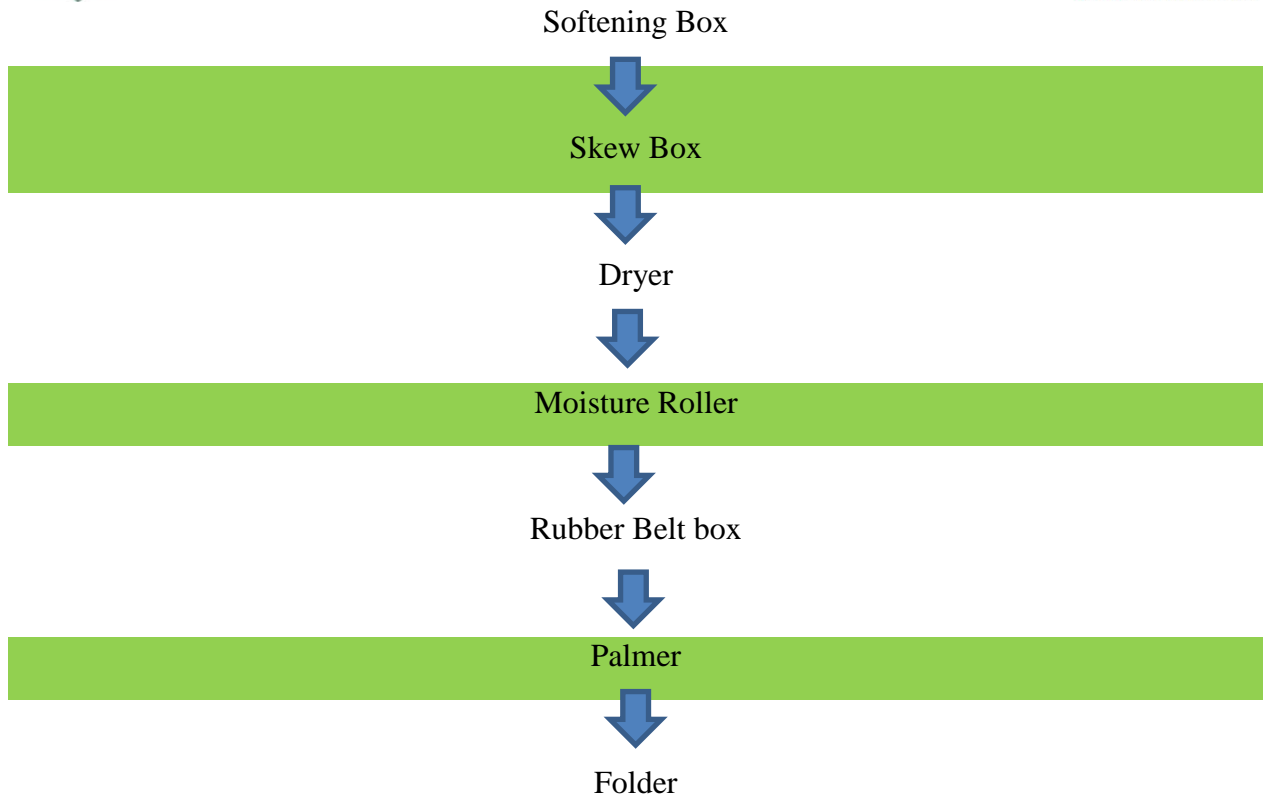
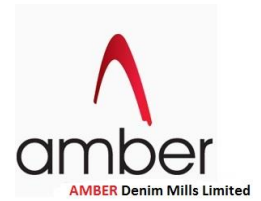
### 8.8.1 Normal finish:



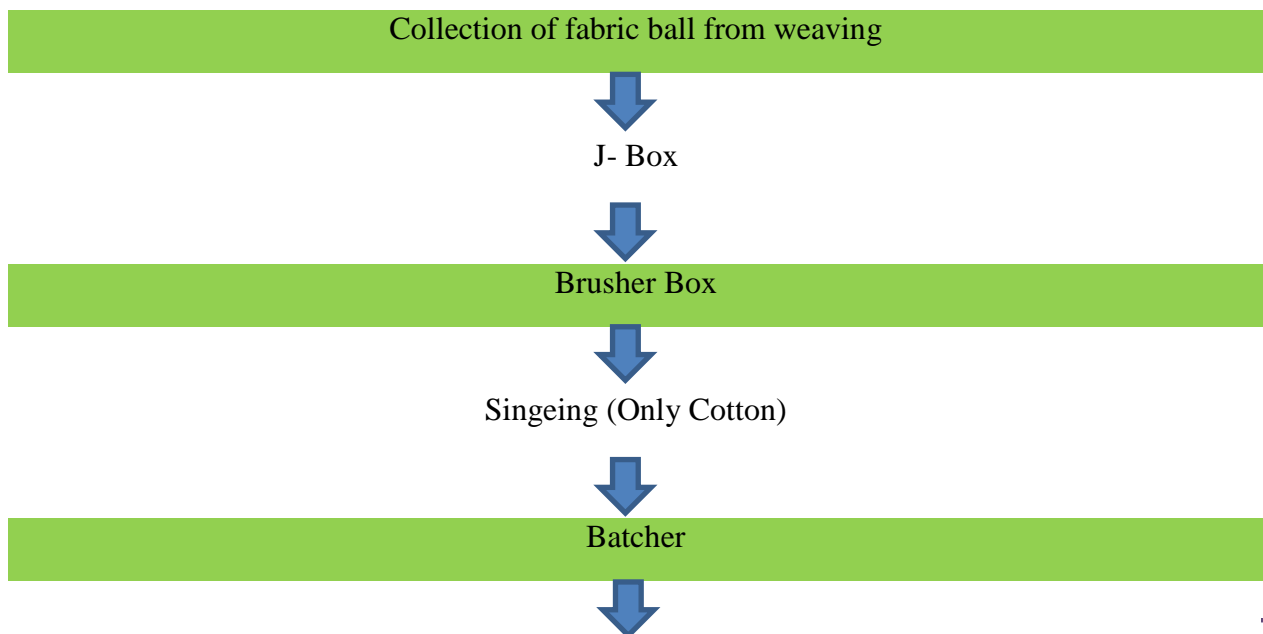


### 8.8.2 Soft Finish:

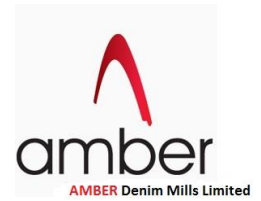


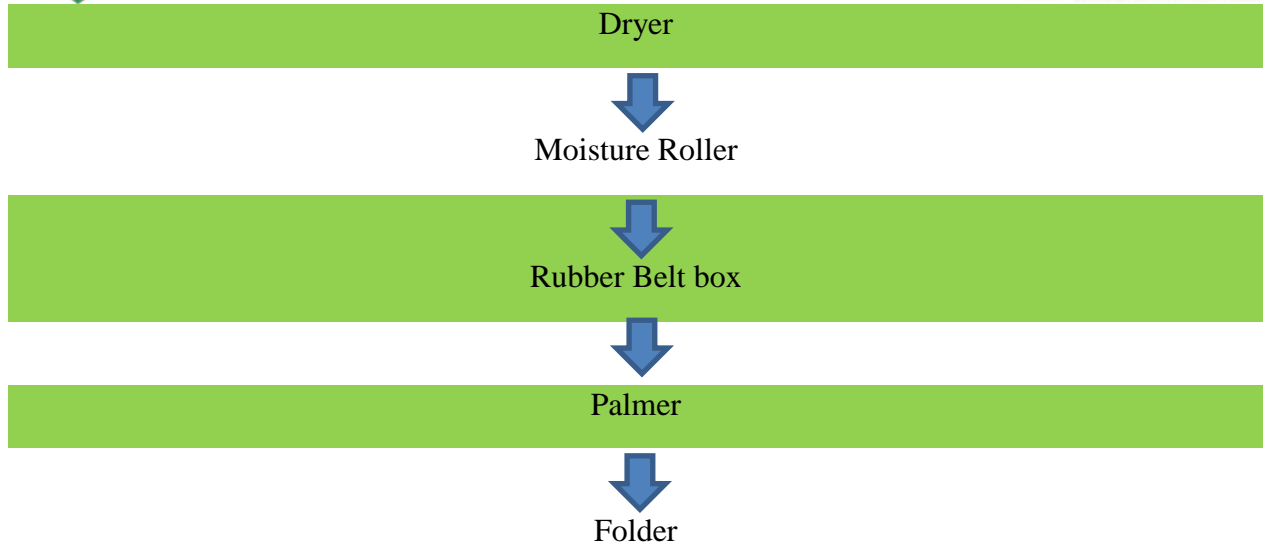
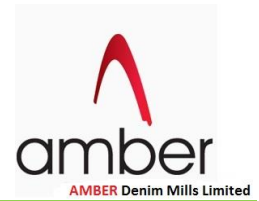


### 8.8.3 Flat Finish:

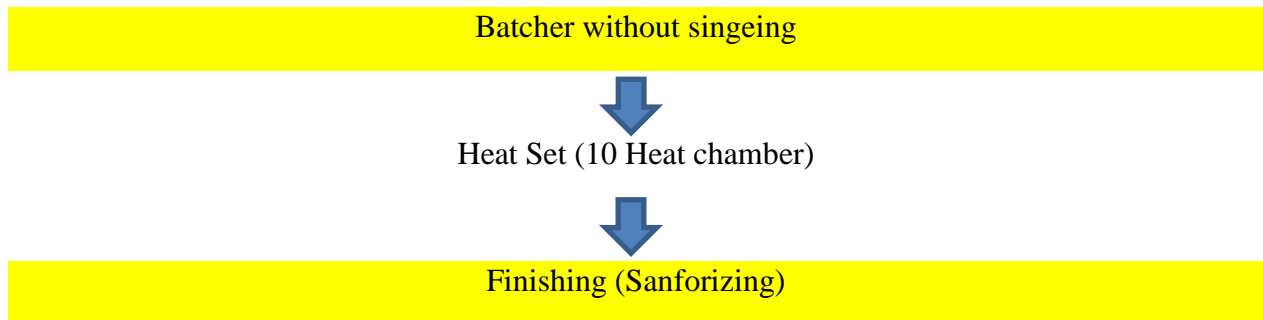




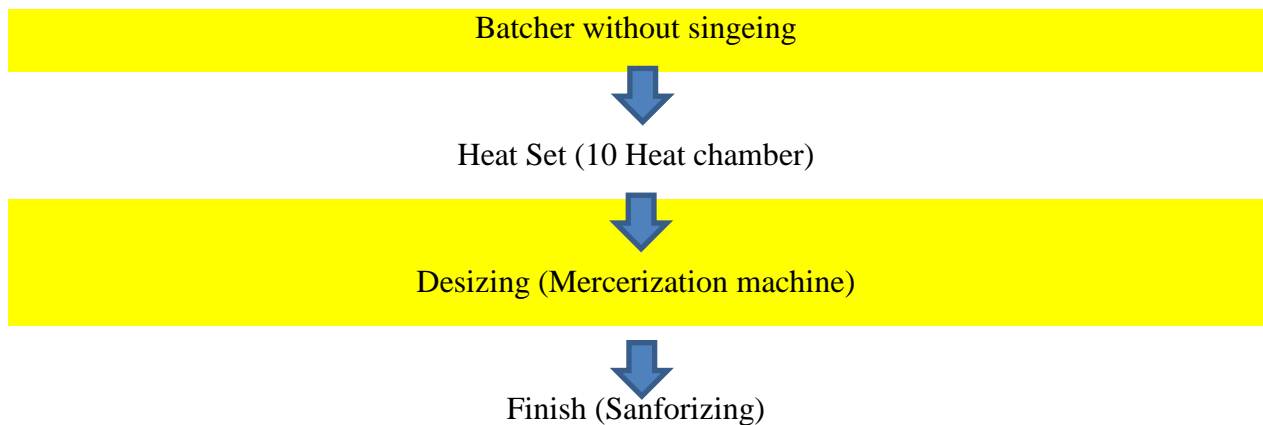


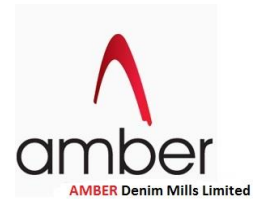


#### 8.8.4 Stenter:



#### 8.8.5 Soft finish Stenter:





### 8.9 Machine specification:

Machine Name	Sanforizing Finishing Machine
Number of Machine	02
Serial No	T-554
Manufacturing Date	2011
Origin	USA
Number of Mechanical Box	5
Number of Chemical Finish box	1
Speed average of different parts	J box= 45 mpm ( Meter per minute)
	Padder= 29 mpm
	Dryer= 30 mpm
	Rubber Belt =30 mpm
	Palmer = 24 mpm
Palmer	Folder = 26 mpm
	84 inch
Rubber belt thickness	56.5 mm

Machine name	Clip Chain Mercerizing
Origin	China
Machine No	LM082B(12)-200
No of wash Box	6 box
No. of chemical Box	3 box
Box Capacity	Anti-staining chemical Box : 941 liter
	Wash Box (1): 2149 liter
	Wash Box (2): 2149 liter
	Caustic Box (1): 800 liter
	Caustic Box (2): 800 liter
	Wash box ( Caustic Box): 600 liter
	Wash box (3-6): 950 liter
No. of padder squeezer roller	9

Machine name	Stenter machine
Origin	China
Type	M5469-700x10
Serial No	15001
Manufacturing Date	2015.03
Number of Heat Chamber	10
Number of Heat Exhauster	2

## 8.9 Sanforizing finishing machine:

### 8.9.1 Introduction

Sanforizing finishing machine is used for finishing of denim fabric. Here removing of hairy fibers, skew, shrinkage control moisture control, calendaring operation etc. finishing process is done. Figure is shown:

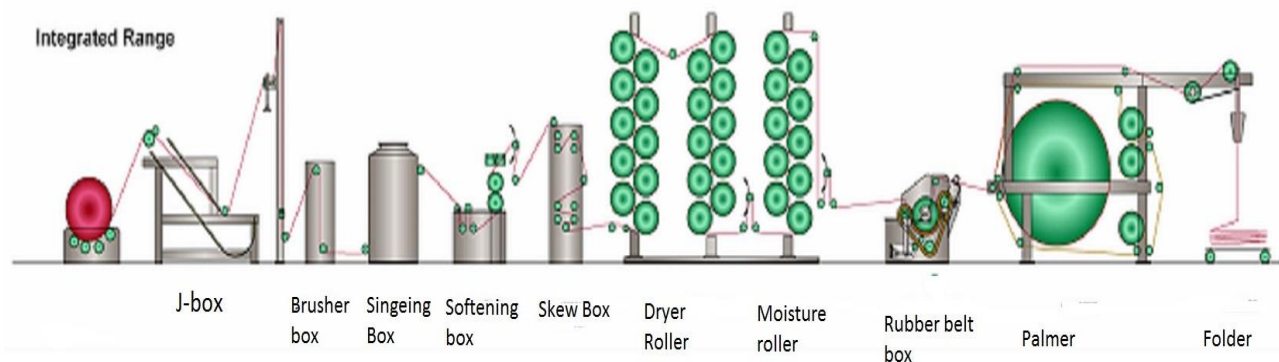
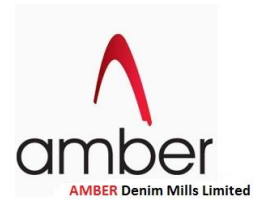


Figure 19: Schematic diagram of sanforizing integrated finish range

### 8.9.2 Machine main parts:

- **J-Box:** J-Box is a shape of J type box that is used to assemble the fabric from the fabric roll which is brought from weaving section.
- **Brusher Box:** In the brushing stage, the grey fabric is brushed to remove the loose lint and loose fluff fibers from the fabric surface. It also raised the protruding fibers on the fabric surface which are removed in the next stage of singeing process.



- **Singeing Box:**

Protruding & hairy fibers from fabric surface is removed by singeing process. These are removed with the help of gas burner, brusher & beating.



Figure 20: Singeing process in ADML

Reasons for Singeing:

- Textiles are first and foremost singed in order to improve their wear and end use properties.
- The burning-off of protruding fiber ends which are not firmly bound into the yarns that provides clean & smooth surface which allows the structure of fabric to be clearly seen.
- Fabrics which have not been singed soil more easily than singed fabrics.
- The risk of pilling formation, especially with synthetic fibers, is extremely low in case of singed fabric.
- Singeing process facilitates and speeds up desizing. This effect, however, is achieved only if the fabric is impregnated with desizing liquor immediately after singeing.
- Scatter of light properties is improved by singeing operation.

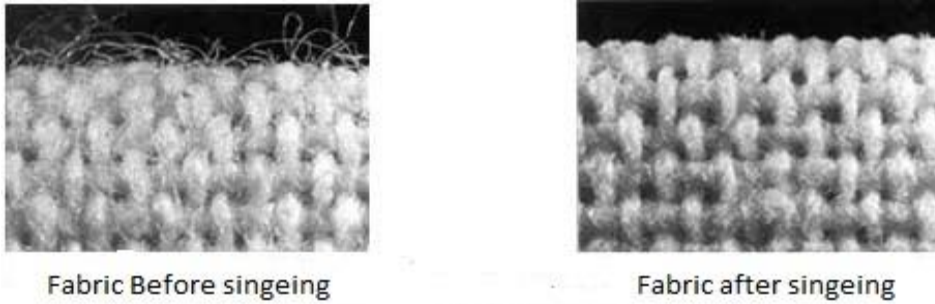


Figure 21: Fabric condition for singeing

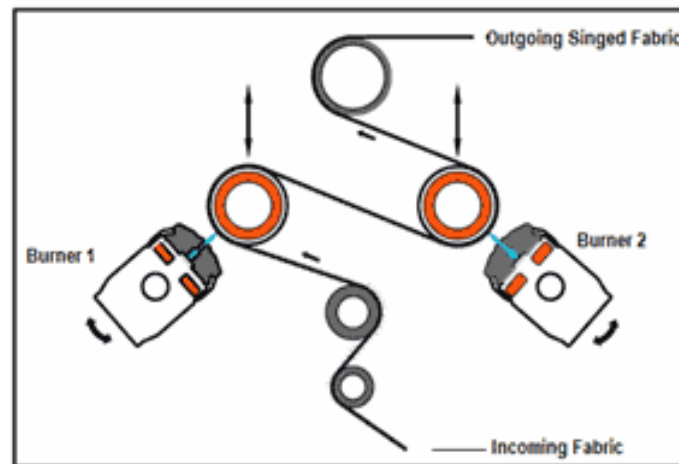
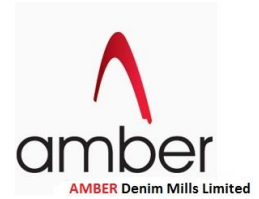


Figure 22: Singeing Operation inside box

- **Batcher:** If the fabric needs mercerization process, heat setting or desizing process, then fabric makes out from batcher & other process has done.
- **Softening Box:** After singeing, softening operation is done with high wet pick up percentage for skew operation. Here the fabric is subjected to a chemical pad treatment. Softeners are often used in the chemical treatment in order to impart soft feeling of the fabric.
- **Skew Box:**  
The skewness in denim fabric, particularly in twill weave creates a serious problem during garment manufacturing and washing. Leg twist is a major problem in denim manufacturing. Due to this problem the leg is rotated in the opposite direction of the twill of the fabric after laundering. Leg twist is assumed to be happening due to the directional



yarn stresses. During washing the yarn stresses is relaxed which change the regular position of interlacement between warp and filling yarns. Due to this reason the legs are twisted. Normally leg twist not shown on garment stage. It only observed after laundering of the garment. Although leg twist appears after first laundering and it increases progressively with repeated launderings.

Ideally warp and weft should be at right angle to each other in normal fabric. Skew in the fabric occurs when the warps are displaced from their vertical position or when the weft is displaced from their horizontal position.



Figure 23: Fabric with skew



Figure 24: Fabric without skew

In case of plain weave fabric, the free spaces in warp and weft direction are equal. Hence the forces acting on all sides of each float are equal, which makes the fabric more stable. However in case of twill weave fabric, at the portion of a float; there is a gap or free space equal to the actual diameter of the yarn. Due to this free space, there may be possible that the floating yarn push away the crossing yarn.



Figure 25: Movement of yarn in twill fabric

In skew box for skewing, fabric is set in a particular angle to remove the skewness of fabric after garments ready, garments washing & laundering.

- **Dryer:** With proper steam & temperature about 100°-120°, dryer is used to dry the fabric. Steam produced by boiler heating the Teflon coated cylinder drum. There are 10 dryer drums for drying.
- **Moisture Box:** In moisture box, proper moisture content of fabric is controller.
- **Rubber belt Box:**  
Sanforizing Machine means a machine consisting of a large steam-heated cylinder, an endless, thick, woolen felt blanket which is in close contact with the cylinder and an electrically heated shoe which presses the cloth against the blanket while the latter is in a stretched condition as it curves around feed-in roll.

### Shrinkage Process:

Sanforizing is a mechanical finishing process of treating textile fabrics to prevent the normal dimensional alternation of warp and weft. It is also called anti-shrinkage finishing process. It is a process of treatment used for denim fabrics mainly and also for some other textiles. It is a method of stretching, shrinking and fixing the woven cloth in both length and width, before cutting and producing to reduce the shrinkage which would otherwise occur after wash.

### Principle:

In Amber denim Mills limited finishing machine, Sanforizing process is based on the principle that when a felt blanket is passed around a metal roller in contact with it, its outer surface is



process extended and the inner surface contracted. So the process is called controlled compressive shrinkage process.

The process of sanforizing includes the stretching and manipulation of the fabric before it is washed.

During the process, the fabric is fed into a sanforizing machine where it is treated with water or steam to promote shrinkage, then pressed against a heated rubber band to relaxation and re-contract the fibers. The amount of potential wash shrinkage must be determined prior to shrinking. A full width sample is wash-tested according to the test method. After the lengthwise and width wise shrinkage has been determined, the compressive shrinkage machine can be adjusted accordingly.

### Process description:

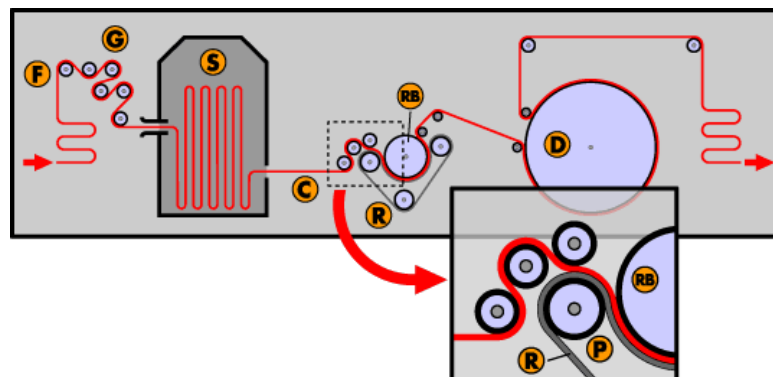
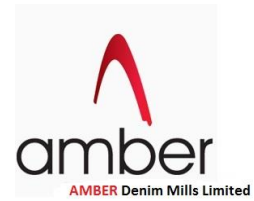


Figure 26: Schematic diagram of Shrinkage process

- Fabric (F) passes through the skyer (S) or other moistening device and is moistened by water and/or steam. This will lubricate the fibers and promote shrink ability within the fabric.
- Fabric is moistened in such a way that every single thread achieves a moisture content of approximately 15%.
- When the fabric passes through the clip expander (C), the required width is obtained. The clip expander also transports the fabric to the most important part of the machine that is the rubber belt unit. (indicated by arrows in above figure).
- In the close-up of above figure R) is the rubber belt . By squeezing rubber belt (R) between pressure roll (P) and rubber belt cylinder (RB), an elastically stretching is obtained of the rubber belt surface.



- The more squeeze the rubber belt, the more the surface is stretched. This point of squeezing is known as the pressure zone, or the nip point.
- When fabric leaving the pressure zone, the rubber belt recovers itself and the surface returns to its original length carrying the fabric with it. The effect of this action is a shorting of the warp yarn which packs the filling yarns closer together. At this actual moment, shrinkage occurs.
- After compaction within the rubber belt unit, the fabric enters the palmer (D). Here the fibers are locked in their shrunken state by removing the moisture from the fabric.
- By this procedure, shrinkage of fabric is maintained.
- **Palmer:** After grey fabric is subjected to singeing, softening, skewness sanforizing etc. it is finally dried to retain its true shape and dimensions. But in this state the fabric becomes least lustrous. Because for those operations the threads in fabric become weavy and crimped. But if a fabric is to appear highly lustrous then its surface should be parallel to each other and all should lie in the length direction.

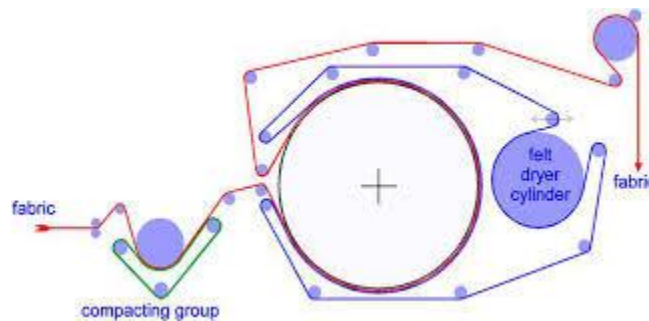
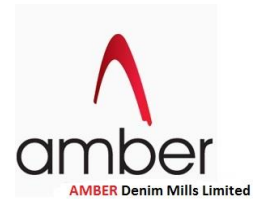


Figure 27: Palmer

### Objects of Calendaring:

- To cause a closing together of the threads of the fabric by flattening them and thus tending to fill up the interstices between warp and weft.
- To produce a smooth, glossy and highly lustrous appearance on the surface of the cloth.
- To reduce fabric thickness.
- To reduce air permeability and water permeability of fabric by changing its porosity.



- **Folder:**  
After all the finishing process, fabric outs from the folder.

## 8.10 Clip Chain Mercerization/desizing machine:

### 8.10.1 Introduction

Mercerization is a physio-chemical process where yarn (cotton) is treated with 15-25% caustic soda solution at a temperature of 200-300C. It is necessary to hold the fabric under tension and wash thoroughly.

Advantages of mercerization:

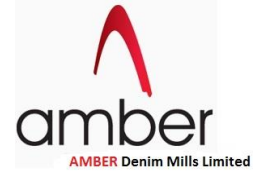
- Increase tensile strength
- Improve hygroscopicity
- Improve dye affinity
- Improve smoothness
- Improve luster
- Improve dimensional stability and physical compactness
- Improve reflection of light

### 8.10.2 Machine parts:

- Loading Box
- Anti-staining box
- Caustic Box
- Caustic wash box
- Clip chain: For the width control of fabric & water removed fully by spraying steam.



Figure 29: Clip Chain



- Wash box/ Desizing Box: Desizing is the process of removing size materials from fabric. This is done simply passing the fabric through some hot water bath for several times. Sometimes softener can be used for better removing of size materials and also for better soft hand feeling. There are four wash box where desizing operation is done. In desizing box, Hot wash is given to the fabric. The temperature of hot water is maintained at 80°-90°C
- Dryer & Moisture box
- Folder

## 8.11 Stenter machine:

### 8.11.1 Introduction:

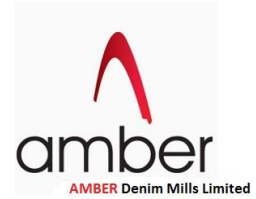
Stenter machine is used for stretching or stentering fabrics. The purpose of the stenter machine is to bringing the length and width to pre determine dimensions and also for heat setting and it is used for applying finishing chemicals and also shade variation is adjusted. The main function of the stenter is to stretch the fabric widthwise and to recover the uniform width.

### Objectives of Stenter Machine:

- Heat setting is done by the stenter for lycra fabric, synthetic and blended fabric.
- Width of the fabric is controlled by the stenter.
- Finishing chemical apply on fabric by the stenter.
- Loop of the knit fabric is controlled.
- Moisture of the fabric is controlled by the stenter.
- GSM of the fabric is controlled by stenter.
- Fabric is dried by the stentering process.
- Shrinkage property of the fabric is controlled.
- Curing treatment for resin, water repellent fabric is done by the stenter.



Figure: Stenter machine



### 8.11.2 Main parts of stenter machine:

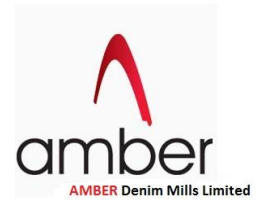
- Padder
- Weft straightner (clip chain)
- Burners 10
- Heat recovery
- Attraction rollers
- Circulating fans
- Exhaust fans 2
- Cooling drums 2

### 8.11.3 Working principles of stenter machine:

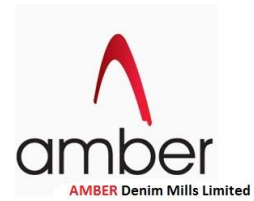
The fabric is collected from the batcher to the scray and then it is passed through the padders where the finishes are applied and sometimes shade variation is corrected. The fabric is entered into the (weft straightner). The function of weft straighter is to set the bow and also weave of the fabric is gripped by the clips and pins are also provided but the pins has a disadvantage that they pins make holes at the selvedge but the stretching of the pins are greater than the clips. These clips and pins are joined to endless chain. There are 8 to 10 chambers provided on the machine each chamber contains a burner and nets are provided to separate dust from air. The circulating fans blow air from the base to the upper side and exhaust fans sucks all the hot air within the chambers. Attraction rollers are provided to stretch the warp yarn.

### 8.12 Controlling Parts & Parameters:

- During singeing, burner pressure can be increased or decreased.
- Shrinkage can be controlled according to buyer's requirements.
- Moisture content for sanforizing process can be controlled by moisture dryer.
- Required width can be achieved by clip chain mercerization machine & stenter machine.
- Desizing operation can be controlled by using required wash bath.



**Chapter Nine**  
**Inspection**



## Inspection

### **9.1 About Inspection:**

Quality is considered as ultimate concern; every single yard of the denim goes through inspection department and rated by a point count system to ensure that quality is up to standard before packing. Defect of fabric pieces are rejected and sold as seconds and relatively minor defective points are marked clearly using stickers to alert cutters.

### **9.2 Inspection Process:**

Fabric batcher is set at the back side of machine equipped with rollers which provides fabric unwinding. Inspection table is laminated white to enhance the defect identification. Four tube lights are provided to optimize the lighting. Measuring counter is provided in front of the inspection table for controlling length. It has forward, reverse, start and stop button controls. Inspection is carried out on white board table. The cloth is pulled over the white board table by a variable speed motor and different cloth defects are recorded for quality control purpose. They inspect the fabric according to 4 point system. After inspection fabric is wound on roller.

### **9.3 Four Point system:**

This is issued by the American Society for Testing and Materials with reference to the designation: (ASTM D5430-93). Faults are scored with penalty points in 1 square yard of fabric.

Size Of Defect (Length in Inches)	Penalty Points
3 inches or less	1
Over 3 inches but less than 6 inches	2
Over 6 inches but less than 9 inches	3
Over 9 inches to 36 inch	4

### **9.4 Inspection in Amber Denim Mills Limited:**

Quality assurance is important for denim. Every yard of denim goes to inspection section and rated by a point count system to ensure the quality of denim before packaging. More defective denim is rejected and lower defected denim is marked with stickers for cutters. In our Amber Denim Mills Ltd. Inspection, Here for inspection, four point system is used.

### 9.5 Machine Specification:

<u>Machine Name</u>	Suntech Textile Machinery
Total Inspection Machine	13
Model No.	SI-KFIM-III-30
Speed of machine	5-80 m/min
Serial No.	347
Manufacturing Date	04.12.2011

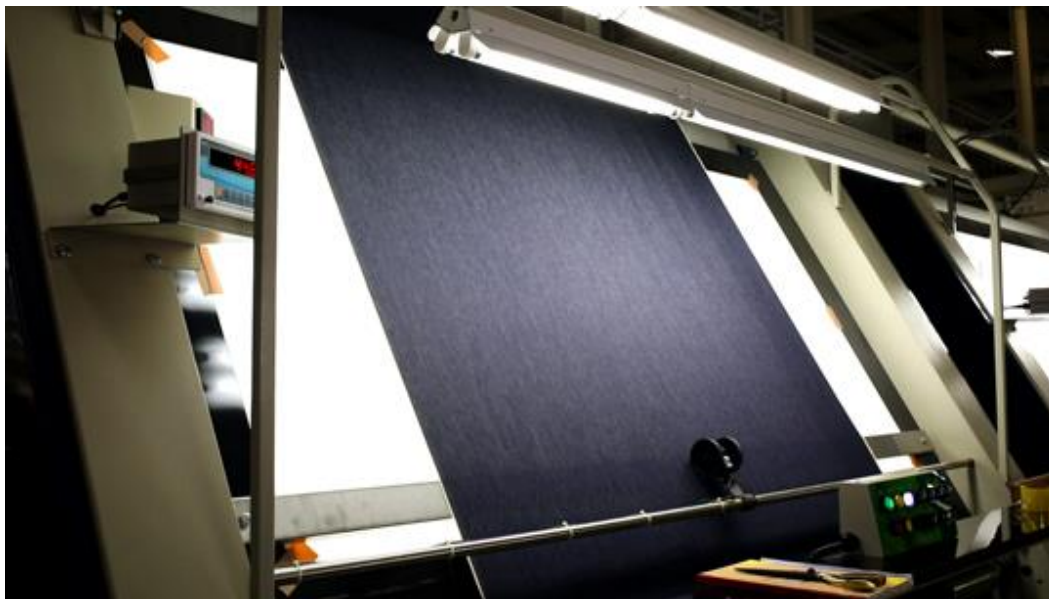


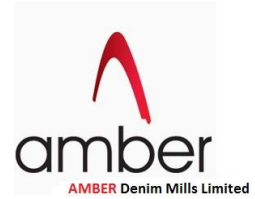
Figure 30: Inspection machine in ADML

### 9.6 Fabrics Defect:

Fabric Defects are divided into two types:

- ❖ Removable defects
- ❖ Non removable defects





### **9.6.1 Removable Defects:**

The defects which can remove during inspection operation are called removable defects.

### **9.6.2 Non removable defects:**

The defects which cannot remove during inspection are called non-removable defects.

## **9.7 Major Fabric Faults:**

### ▪ Starting mark:

Causes: Main cause is loom stoppage.

Remedy: This cannot be avoided but can be controlled by starting mark setting.

### ▪ Reed mark:

Causes: If any fault occur at reed Faulty denting in the reed.

Remedy: Right selection of the reed and right denting.

### ▪ Snarl:

Causes:

- Excess main nozzle pressure
- Low filling tension

Remedy:

- Main nozzle air pressure control
- Correct setting of the PFT finger value

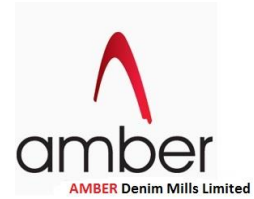
### ▪ Double pick:

Causes:

- Cutting problem of the cutter.
- Faulty setting of the air pressure.

Remedy:

- Cutter position is to be set correctly.
- Air pressure should be reset.



- Miss pick/ broken pick:

Causes: Excess air pressure of main nozzle

Remedy: Main nozzle air pressure should be reduced

- Warp breakage:

Causes:

- Bad sizing
- Low strength of the yarn
- Crossing of the warp yarn

Remedy:

Re knotting Proper sizing

- Loose or Tight (sizing Fault):

Causes: knotting is given, when yarn breaks, the yarn tension does not match with other yarn as a result loose or tight occurs.

- Filling Stop:

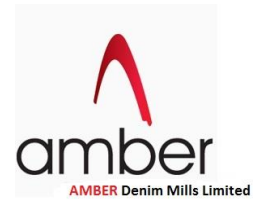
Causes:

- If weft is failed to reach FD1
- If weft is too long & reach FD2

Remedy:

- Correct setting of the weft length
- Correct setting of main nozzle
- Correct setting of relay nozzle
- Proper setting of air pressure
- Proper setting of pre-winder
- Proper setting of creel position

- Oil Mark or Crease, Hole:



When fabric gets spots of oil lubrication from any part.

- Contamination:

It is a yarn fault, Plastic Others are mixed with yarn.

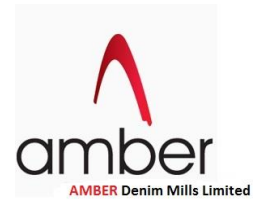
- Coarse

Due to Improper fabric weaving.

WARP YARN		WEFT YARN		DYEING		SIZING		WEAVING		FINISHING	
Coarser warp yarn	101	Coarser Weft	701	Shade variation	201	Loose	301	Broken pick	401	Crease	501
Finer warp yarn	103	Finer Weft	703	Stain	202	Tight	302	Double Pick	402	Weave	502
Dirty warp	105	Oily Weft	705	Stop mark	203	Beam stain	303	Miss Pick	403	Width variation	503
Slubbyness warp	107	Slubbyness Weft	707	S.S.V	204	Size spot	304	Lashing	404	M/C Stop	504
Warp contamination	108	Weft contamination	708	Dyeing patta	205	Bad selvedge	305	Starting mark	405	Stain	505
Warp ball formation	109					Less width Slack end B.F	306	Reed mark	406	Hole/Torn	506
						Slack end	307	Knot	407	Sleeve mark	507
						B.F	308	Snarl	408	E.H mark	508
								Smash	409	Up singed	509
								Stain	410		
								Bad selvedge	411		
								Floating end	412		
								Double end	413		
								Wrong drawing	414		
								Less width	415		
								Weave	416		
								Hole	417		
								Crease mark	418		

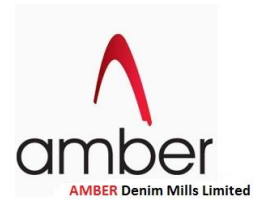


9.8 Defects & code no of defects in ADML:



## Chapter Ten

# Denim Washing



## Denim Washing

### **10.1 Denim Washing:**

Denim has been used as clothing material for centuries due to its high durability. But today's fashion arena likes denim jeans due to its attractive shades, designs, attractive styles and various types of wash appeal, rather than for its robustness. Washing treatment on denim garments offers an aesthetic finish, enhanced the appearance of fabric. Different types of denim washing is available in order to meet the requirements of today's denim fashion trend.

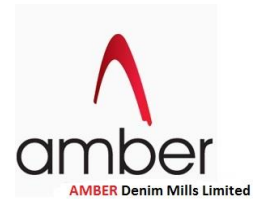
The denim jeans are subjected with different washing techniques, such as bleach wash, enzyme wash, acid wash, stonewash, moon wash, sand wash, sun wash, over dyed/ tinted look, whiskering, damaged, used look. In denim washing, enzymes played an important role to get clean, smooth, fuzz free fabric surface with reduced tendency of pill formation and improved fabric handle. Traditionally, indigo denim fabric is deep blue in shade. Denim finish may be of two types, such as raw denim and prewashed denim. In raw denim, the denim is not washed after weaving. Raw denim jeans shows natural shade of indigo which is faded during wear and subsequent washes at home.



Figure 31: Denim washed Jeans

#### **10.1.1 Reasons for Denim Washing:**

- ❖ Influence the physical properties such as softness, handle, drape, absorbency and creasing.
- ❖ Influence appearance by altering the nature of yarn of fabric or luster.
- ❖ Give shrinkage effect and puckering of garments
- ❖ Create trend in fashion consistent quality and brand image with range of finishes.



### 10.1.2 Objectives of denim washing:

- ❖ **To develop softness in garments:** dirt, dust and Size materials applied during manufacturing present in the fabric are removed which enhances soft hand feel. Additional softness may be attained by using softener.
- ❖ **To introduce fading effect:** Dyes or pigments are present in the fabric, used during dyeing, are washed out close by or partially which result fading, old look, tinted or over dyed effects in the garments.
- ❖ **To create new fashion:** Washing Process of garments bring different outlook (faded, color tinted etc.) thus creating new fashion for the new generation especially for youngsters.

## 10.2 Types of Washing:

Denim washing are of two different types.

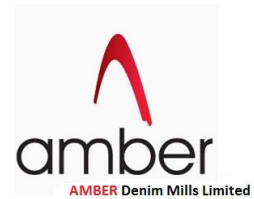
1. Mechanical wash
2. Chemical wash

Chemical washes of denim fabric may be of different types:

- ❖ Denim Bleaching wash
- ❖ Enzyme washing
- ❖ Acid washing
- ❖ Rinse wash
- ❖ Ozone fading
- ❖ Snow wash
- ❖ Salt water denim
- ❖ Sun washing
- ❖ Super dark stone

Mechanical denim washes are stone washing and micro sanding. During stone washing, stones are used in order to achieve typical washing effect. There are three types of micro sanding, such as:

- ❖ Sand blasting
- ❖ Machine sanding
- ❖ Hand sanding
- ❖ Whiskering
- ❖ Water jet fading
- ❖ Super stone wash
- ❖ Ice wash
- ❖ Laser technology finish



### **10.3 Denim Washing in AMBER Denim Mills Limited:**

Amber Denim Mills Limited has not a wide washing plant although they have a small washing unit. It is just used for product development and buyer swatch match. Though it is an important topic that's why we have tried to give some information about Denim washing for understanding. Beside these washes,

Mainly four types of Sample washing are done in ADML. These are:

- Enzyme wash
- Bleach wash
- Stone wash
- Acid wash

### **10.4 Machine Used for Denim Washing:**

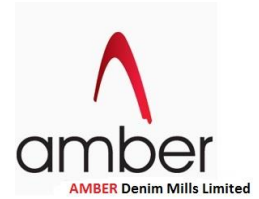
#### **10.4.1 Industrial washing machine**

##### **Features:**

- ❖ Single door design for general washing, sweater and sample washing machine.
- ❖ Automatic washing timer and pre-set front and backward rotation.
- ❖ Option to install 4 steps gear box or frequency controller for speed control for different requirement of garments.



Figure 31: Industrial Washing Machine



#### 10.4.1.1 Machine Specification:

<b>Machine Name</b>	<b>YILMaK</b>
<b>Origin</b>	Turkey
<b>Model</b>	HBM 250 S
<b>Construction Year</b>	2013
<b>Drum Speed</b>	0-40 rpm

#### 10.4.2 Industrial Washing Machine:

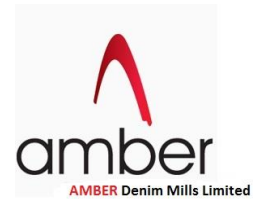


Figure 32: Industrial Washing Machine

#### Features:

- ❖ doors, 2 chambers design
- ❖ Special for sand wash purpose
- ❖ Automatic washing timer and preset front and back rotation
- ❖ Option to install 4 steps gear box or frequency controller for speed control for different requirement of garments.
- ❖ Option with water level ruler





### 10.4.3 Industrial Water extractor:



Figure 32: Dewatering Machine

#### Features:

- Special Design for Industrial Laundry
- Stainless steel inner basket, durable and strongly built
- Equipped with shake absorbing spring
- With hand clutch for fast-stop
- Installed with insulated motor and automatic clutch for fast start and longevity.

### 10.4.4 Industrial Dryer:



Figure 33: Industrial Dryer

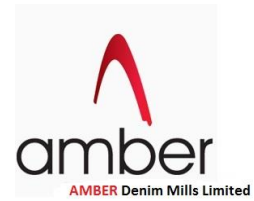
#### Features:

- Preset forward and backward rotation of inner basket.
- Stainless steel inner basket, clean and durable Equipped with thermostat.

## 10.5 Description of Washing Types:

### 10.5.1 Desizing:

Desizing is the process of removing the size material from the warp yarns after the textile fabric is woven. This is the most important part of denim washing.



During sizing, the warp yarn threads are treated with auxiliary chemicals known as sizing chemicals which impart the strength, friction resistance during weaving. The purpose of sizing is to protect the thread by coating. Different types of sizing chemicals are used like Starch, Modified starch, polyester, polyacrylates, polyvinyl alcohol, polyvinyl acetate, CMC etc. During washing, those chemicals must be removed to bring desired look on the fabric.

#### 10.5.1.1 Objects of desizing:

- ❖ Removing the impurities which came from fibre or different manufacturing processes like oil, fats or alkaline chemicals, dirt's, dusts etc.
- ❖ Removing the sizing chemicals used in weaving
- ❖ Decreasing the crease risk on the garment etc.

#### 10.5.2 Enzyme wash:

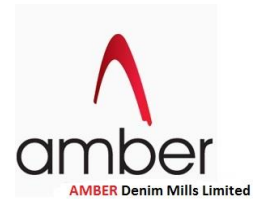
Enzymes are proteins produced by living organisms. Some enzymes can be replicated in the laboratory, or engineered to perform in a specific manner. Enzyme washing is ecologically friendly due to the natural origins of enzymes, which biodegrade, instead of lingering in the water supply. Additionally, Enzyme washing products are much more potent than other laundry products, calling for far less volume in terms of quantity.

Among the two traditional enzymes used in the treatments of denim garments (amylase to hydrolyze starches and cellulose to degrade in different way's cotton's cellulose) there is another enzyme that can be employed to attack selectively the molecule that constitutes the blue indigo colour resulting ineffective on other kind of dyes.



Figure 35: Enzyme wash Denim

The action of enzyme during enzyme wash, it hydrolysis the cellulose, at first it attacks the having projecting fiber and hydrolyzed them. Then it attacks the yarn portion inside fabric and partly hydrolyzed the yarn portion and faded affect is produced.



### 10.5.3 Bleach wash

Denim bleaching normally carried out with a strong oxidative bleaching agent such as sodium hypochlorite or  $KMnO_4$ . Bleaching may be carried out with or without the addition of stone. The bleaching washing effect and de-coloration usually depends on strength of the bleach liquor, liquor quantity, temperature and treatment time. The bleached fabric materials should be properly anti chlored or after washed with peroxide to reduce the subsequent yellowing or tendering of the bleached denim fabric.



Figure 36 : Bleach wash denim

### 10.5.4 Sand Blasting

Sand blasting is a mechanical process in which localized abrasion or colour change on the denim garment is created. The process involves blasting an abrasive material in granular, powdered form at a very high speed and pressure through a nozzle onto certain areas of the garment such as knees and elbows. The garment treated surface shows distressed, abraded or used look. The common blasting materials used are sand and metal granules.

During sand blasting process the garment are first subjected to stone wash to the desired degree of washing. It is then sand blasted.



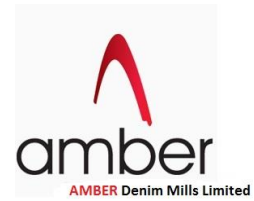


Figure 37: Sand blasting denim

### 10.5.5 Acid Wash:

Acid wash on denim jeans is becoming very popular due to its significant contrasts and attractive appearance in color. Acid wash can be carried on Indigo & Sulphur base fabric garments. Acid wash was a chemical wash process on denim which stripped the top layer of color and makes a white surface while the color remained in the lower layers of the material, giving it a faded look. Acid wash of denim garment normally carried out by tumbling the garments with pumice stones presoaked in a solution which contains sodium hypochlorite (5 to 10%) or potassium permanganate (3 to 6%). This causes localized bleaching which produces non-uniform sharp blue/white contrast.

Acid wash can be done in 4 systems. These are:

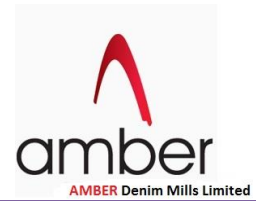
- Ball Wash
- Caustic ball
- Towel
- Pumice Stone



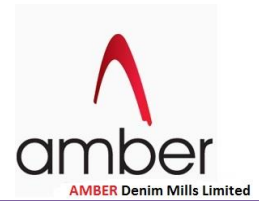
Figure 38: Acid wash denim

### 10.6 Washing Chemical Used in ADML:

Chemicals	Function
Bleaching Powder (KCl)	Bleaching agent Fabric can be light Shade match is possible
Lava Cone FF	Enzyme agent Fabric effect can be found.



<b>Gantiback NBB-35 cone</b>	Anti-staining agent Traps the fabric color in a particular area so that the dye will not penetrate in other surface.
<b>GT-Anticrease</b>	Used for removing crease mark that occurs in weaving
<b>GT DFT NI</b>	Detergent Lightening effect increase.
<b>GT Soft HT 50</b>	Softener
<b>GT Silk MF</b>	Super soft chemical. Make fabric silk like smoothness.
<b>GT. Fix</b>	Fixing agent
<b>Hydrogen Peroxide</b>	For lightening the fabric. Reduce reddish tone
<b>Caustic Soda</b>	For lightening of fabric
<b>Gzyme CBE-400</b>	Liquid Enzyme Removing neps, lightening enrich, reduce reddish effect.
<b>Gzyme N-99</b>	Powder Enzyme Removal of Neps, effect etc.
<b>Gzyme Ultra Plus</b>	Desizing agent To remove the size material
<b>Hi-Chlon 65</b>	High power Bleaching agent Increase blue tone in fabric.
<b>Hydroxyl Ammonium Sulphite</b>	Neutralize agent Bleached chemical neutralized
<b>Pumic Stone</b>	A stone Gets effect in the fabric
<b>Soda Ash</b>	For lightening the fabric
<b>Sodium Metabi Sulphite</b>	Neutralize agent Used for neutralization.
<b>Sodium Thiao Sulphite</b>	Neutral agent Used for neutralization.



### 10.7 Washing Recipe for a leg piece:

#### 10.7.1 Desizing recipe:

Chemical/Components	Quantity
Water (Hot)	30 liter
Gzyme ultra plus	1 gpl
Gantiback	1 gpl
Min	5 min
Temperature	55°C

Wash after desizing:

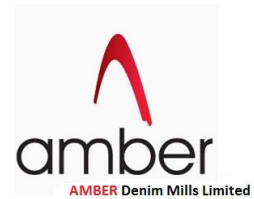
Wash	Cold wash
Min	1min
Water	30 liter

#### 10.7.2 Enzyme Wash recipe:

Chemical/ Components	Quantity
Liquid enzyme	1 gpl
Gantiback	1 gpl
Acetic Acid	0.5 gpl
Min	5 min
Water	30 liter
p <sup>H</sup>	4-5
Temperature	40°-45°C

Wash after enzyme wash:

Wash	Cold wash
Min	1min
Water	30 liter



### 10.7.3 Bleach wash:

Chemical/ Components	Quantity
Hi-Chlon 65	600 gm
Min	5 min
Water	30 liter
Temperature	50°-60°C

### Wash after bleach wash:

Wash	Cold wash
Min	1min
Water	30 liter

### 10.7.4 Neutralization:

Chemical/ Components	Quantity
Sodium Thio Sulphite	1 gpl
Water	30 liter
Temperature	24°C

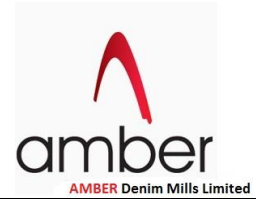
### Wash after neutralization:

Wash	Cold wash
Min	1min
Water	30 liter

### 10.7.5 Acid wash recipe:

Chemicals/ Components	Quantity
Pottus	650 gm
Min	5 min
Water	45 liter
Temperature	30°C

### Wash again after acid wash:



Wash	Cold wash
Min	1min
Water	30 liter

### 10.8 Washing Procedure:

- Firstly put the sample in the industrial washing machine & done desizing process according to recipe.
- After desizing for 5 minutes, unloaded the machine & washed the fabric again for 1 min.
- After washed, enzyme washing is done according to recipe. After 5 min of enzyme wash, unloaded the machine & washed the fabric again for 1 min.
- After enzyme wash, bleach wash has done. For bleach wash is done according to recipe. After 4 min of bleach wash, unloaded the machine & washed the fabric for 1 min. After washed, checked the shade or fading of the fabric.
- Then neutralization process is done. With neutralizing agent neutralized the fabric for 5 min. then unloaded the machine & washed the fabric for 1 min.
- Then the fabric is dewatering into hydro extractor. There the fabric is dewatered with the help of hydro extractor.
- Then dried the fabric into the industrial dryer at 70°C for 18 minutes.

### 10.9 Most Common Denim Washes:

#### ❖ Destroyed/damaged/used/whiskers:

Whiskering, also known as 'Cat's Whiskers', are the crease lines around the crotch. Whiskering can be done on the sides of knee and crease marks on the back of the knee. During natural wear, in the portion of a crease, Pigment is removed.

Denim garments can be made of old, worn and /or used look by several different ways, such as with the help of laser, sandblasting, machine sanding, hand sanding or abrading by some kind of power tool. With the help of a grinder, whiskering can be produced around the hip to crotch area of the pant. Damaged look of a denim pant can be made by cutting the edges at different areas before washing, such as at bottom, pockets, fly and knee area.



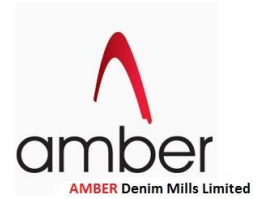


Figure 39: Whiskering denim

❖ **Torn Jeans:**

Some jeans are teared at some places in order to get natural tearing look. The fabrics have actual rips, holes, tears and/or lacerations.

❖ **Flat Finish:**

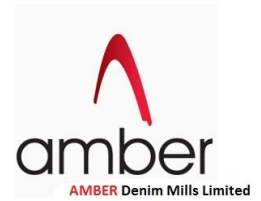
Flat finish of denim fabric involves mercerization plus calendaring processes to achieve the flat surface. It imparts an even wash down effect and clean surface. The mercerization process swells up the cotton fibers which is pressed in calendaring to achieved a flat surface.

❖ **Ice Wash:**

Ice washing is a type of denim washing in which almost half the dye is removed during washing.

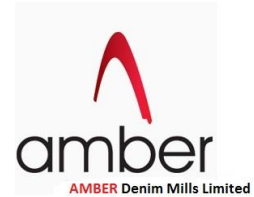
❖ **Sun Washing:**

Sub washing of denim fabric imparts a sun faded appearance to denim garments. It is carried out by bleaching and stoning of the denim garments.



## Chapter Eleven

# Utilities



### 11.1 Definition:

Utility section is very important section for the construction of an industry. Without Utility section, an industry cannot complete. The definition of utilities can be expressed in many ways.

- A company that generates transmits and/or distributes electricity, water and/or gas from facilities that it owns and/or operates.
- An economic term referring to the total satisfaction received from consuming a good or service.

Production and profit are closely related. In order to get a quality final product, it needed fresh raw materials as well as effective manpower and machinery in good working condition. Utility plays a vital role to maximize the production as well as the profit.

A utility system used in industrial facilities. This area includes boilers, chillers, cooling towers, air compressors, and their associated fluid distribution systems.

### 11.2 Utility section of AMBER Denim Mills Limited:

Utility department of **Amber Denim Mills Ltd.** is related to the following things:

- ❖ Electricity: Gas Generator, Rural electrification Board (REB)
- ❖ Water: Deep Tubewell
- ❖ Gas: TITAS
- ❖ Steam: Boiler
- ❖ Compressed air: Air compressor
- ❖ Chiller
- ❖ Effluent Treatment Plant (ETP)
- ❖ Water Treatment Plant (WTP)

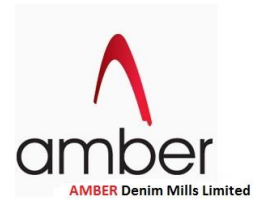
### 11.3 Water Supply:

Water is supplied by deep tubewell. There are two tank main & reserve tank for water storage. The level of water is monitoring continuously and reading is taken in every hour. A daily report is prepared for that and this water is supplied to many sections like dying, boiler, generator, compressor etc.

Total water consumption: 700m<sup>3</sup>/day.

### 11.4 Boiler:

A steam generator or boiler is usually a closed vessel made of steel for supplying steam. Boiler function is to therefore the heat produced by the combustion of fuel (here gas is used) to water



and ultimately to generate steam. The steam produced in the boiler section supplied to different section of mill.

Supplied sections for steam:

- Sizing
- Finishing
- Dyeing unit
- Washing unit
- Chiller

In ADML, two types of boiler have been used. These are:

- ❖ Thermox Indian Boiler ( Capacity of steam: 16 ton per hour)
- ❖ Adjust Pro Generation Boiler (Capacity of steam: 2.8 ton per hour)

Steam required in different section:

- ❖ Dyeing Zone: 4 ton per hour
- ❖ Sizing Zone: 4.5 ton per hour
- ❖ Finishing zone: 9 ton per hour

Key Features:

- ❖ Designed and manufactured to the latest international standards.
- ❖ Full wetback design thus minimizing radiation heat loss and refractory maintenance.
- ❖ Large furnace volume assures high combustion efficiency and for a wide variety of fuels to be burnt efficiently.
- ❖ Compact in construction yet designed for easy access, important for internal inspection,
- ❖ Cleaning and maintenance.



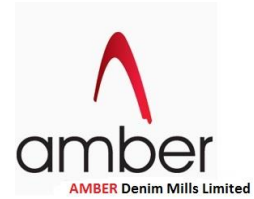


Figure 40: Industrial Boiler

## 11.5 Generator:

An electrical generator is a machine, which converts mechanical energy into electrical energy. The energy conversion is based on the principle of the production of dynamically induced e.m.f. When a Conductor cuts magnetic flux, dynamically induced e.m.f. (Electro magnetic Force) is produced in it according to flow if he conductor circuit is closed.

### Features:

- 12 cylinders turbocharged and intercooled
- Fully integrated engine diagnostic and control system including:
  - Spark timing control
  - Turbocharger control
  - Speed governing
  - Individual cylinder knock detection
  - Air/Fuel ratio control
- Fuel tolerance
- High altitude capability
- Low Btu option
- Rich burn combustion

In **Amber** Denim Mills Limited there are four generators which capacity is given below:

- Capacity: Per generator 1.063KWh (4 generator)
- 17000 KW/h electricity generates by per machine.
- Required total electricity in all section: 65000KWh per 24 hour

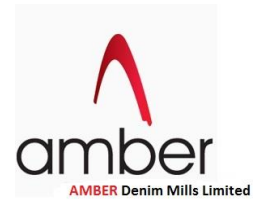


Figure 40: Industrial Generator

### 11.6 Air Compressor:

Compressed air along with gas, electricity and water is essential to most modern industrial and commercial operations. It runs tools and machinery, provides power for material handling system and ensures clean breathable air in contaminated environment. In Partex Denims rotary screw compressor is used.

In **AMBER** Denim Mills Limited, there are four 8 air compressor is used.

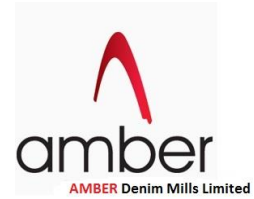
### 11.7 Chiller:

A chiller can be generally classified as a refrigeration system that cools water. Similar to an air conditioner, a chiller uses either a vapor compression or absorption cycle to cool. Once cooled, chilled water has a variety of application from space cooling to process use.

There are two types of chiller:

1. Vaporization Chiller
2. Absorption Chiller

In **Amber Denim Mills Ltd.** the absorption type of chiller is used. There are two chiller machine is used.



## 11.8 AC Plant:

Humidifier is a system to provide proper humidity and temperature in a working space. To maintain the proper humidity and temperature in a weaving mill is very important. Different electrical circuit board of weaving machine cannot work for a long period without proper temperature and humidity. Proper humidity helps to remove the producing static electricity due to friction of different machine parts.

### 11.8.1 Working Principle:

There are three dampers in the humidification plant. By two damper airs from outside into the plant and. by another one re circulated air again supplied to the plant. There is a passage to a cooled water sprayed area. Here the cooled water (6-7OC) is sprayed to the air. The cooled water is supplied from the chiller. Then this cooled air pass in the weaving section by duct line. The air from the conditioned space (weaving section) again sucked by the underground duct. This air is full of dust, lint, fibre etc. Then a filter a part of this air again re circulated in the plant filters this air and rest of the air is leave to the outside.

In **Amber** Denim Mills Limited there are four AC plant. Section that required the humidification system is:

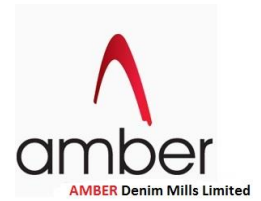
- Ball Warping Section (one AC plant)
- Long Chain Beamer (LCB) section (one AC Plant)
- Weaving section (Two AC plant)

## 11.9 Effluent Treatment Plant (ETP):

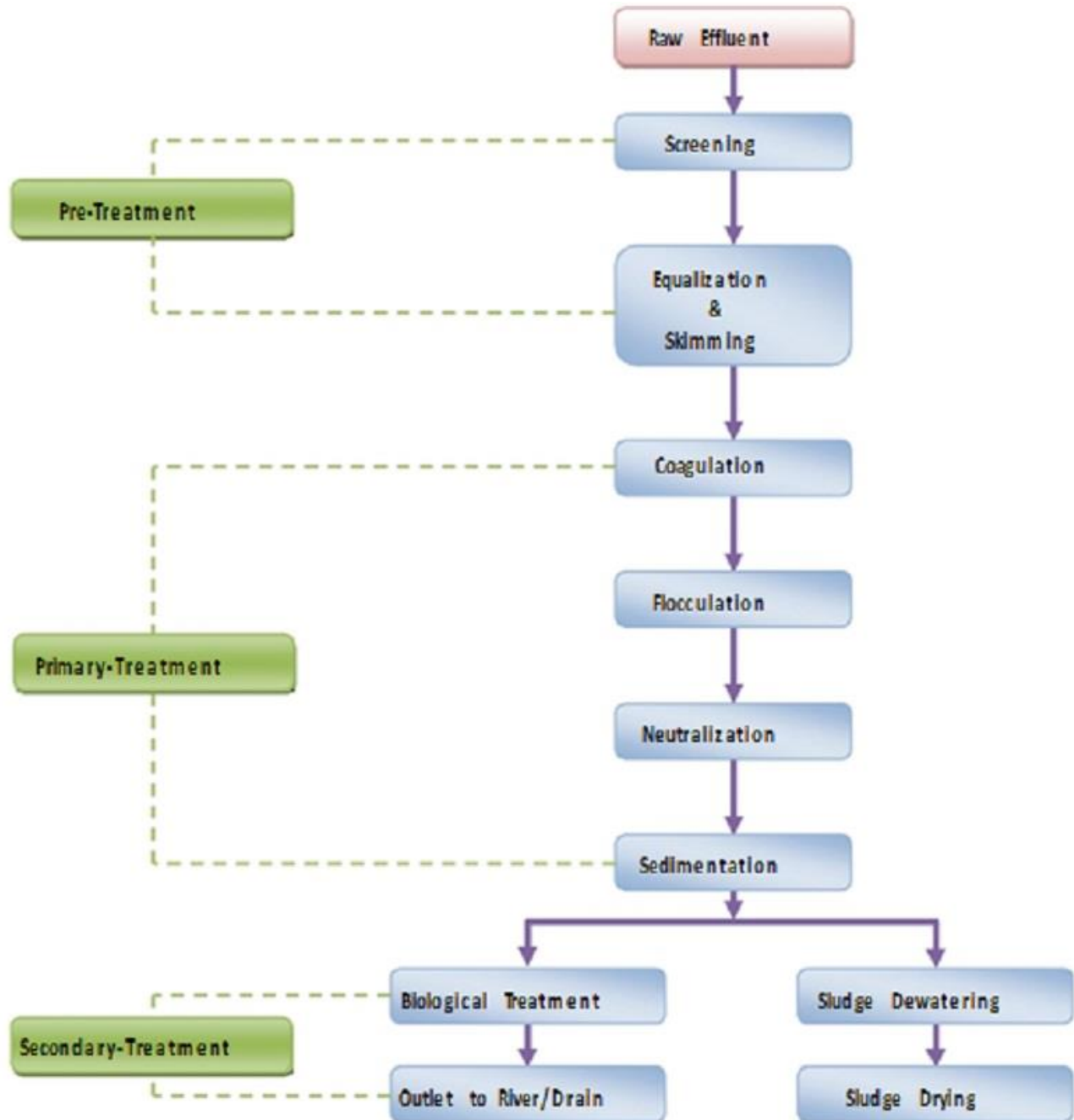
Effluent Treatment Plant (ETP) of Amber Denim Mills Ltd. has successfully established in the beginning and running continuously 24 hours a day. They are maintaining all the discharged parameters according to environmental law. The ETP plant of ADML is a biological treatment plant where water purifies with the help of bacteria.

The effluent treatment plant has been designed on the basis of the following:

- Denim fabrics manufacturing plant.
- Contaminated effluent is 100%
- Less contaminated is nil
- Operated continuously for 24 hours a day
- Flow rate of treatment envisaged is 30m<sup>3</sup>/hr.



### 11.9.1 Process of Effluent treatment plant (ETP):





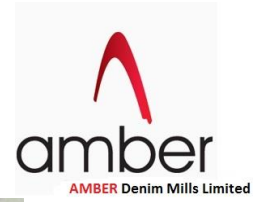
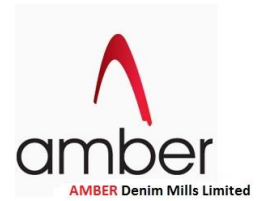
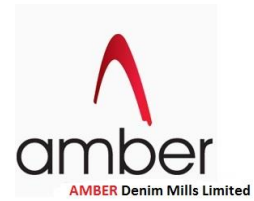


Figure 41: Effluent treatment plant in ADML



## Chapter Twelve

# Research & Development (R&D)



## Research & Development (R&D)

### **12.1 Research & Development (R&D) in Amber Denim Mills Limited:**

Research & Product development department is an important department for any textile industry. This plays a direct role on developing a product.

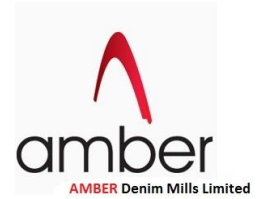
**Amber** Denim Mills Ltd. has also a Research & Development (R&D) department with modern amenities which correlates very well with the upcoming new product. Continuous research programmed is carried-on here, which is completed by product development. The R&D department is independent and equipped to promptly invent new designs for new fashion and develop buyer's requirements timely. This department keeps all documents from dyeing recipe to fabric construction and keeps master roll to keep shade in same consistent even over a longer discontinuity. Partex always researches to develop new fashion as per the world requirement as well as to maintain comfort & durability.

Most often this department creates new product on the basis of new design & structure by their own creativity according to the current market demand and then give it to the buyer. If this design is approved by the buyer then it is stored. They already developed over 5000 samples. When an order comes from buyer in form of washed sample, the technical person determines the shade percentage, amount and type of washing to that fabric to get the appearance like the sample. So it is very important to wash the sample fabric to justify his assumption. For this purpose a small washing unit is established in the factory.

Every order firstly comes into R&D department via marketing peoples by mail or swatch. The R&D experts analyze these samples and match it with their developed samples. If they find similar samples then this is sent to buyers for approve. If buyers approve it then the R&D section goes for production.

The R&D department also performs different testing solutions. Most modern and efficient lab instruments from Atlas, UK which is operated by trained technicians. The variable light box, Spectrophotometer, Rubbing tester, Washing Fastness, Tensile strength tester, Tear strength tester, Abrasion Resistance tester etc. gives accurate results and helps to keep quality good and more consistent.

Lab reports of a running lot are constantly maintained. After each process a sample for testing is sent by the production staff usually after many meters of run. Lab reports contain information about various tests performed according to buyer requirements and their results with remarks of responsible staff about the fabric.



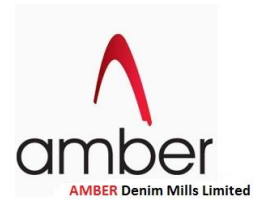
## 12.2 Testing in R&D:

The tests that can be performed in (R&D) are:

- ❖ Skew
- ❖ Weight (Oz/Yd<sup>2</sup>)
- ❖ Shrinkage warp%
- ❖ Shrinkage weft%
- ❖ Pilling ICI
- ❖ Tensile strength
- ❖ Wash fastness
- ❖ Rubbing Fastness

## 12.3 Equipments Used in R&D:

- ❖ Quickwash Plus
- ❖ Pilling Tester
- ❖ Rotawash
- ❖ GSM balance
- ❖ GSM cutter
- ❖ Shrinkage Measurement Scale
- ❖ Tensile Strength Tester
- ❖ Rubbing Tester
- ❖ Pilliscope
- ❖ Spectrophotometer
- ❖ Grey Scale



### **Limitations of the report:**

- ❖ We had a very limited time. In spite of our willing to study more clearly & details it was not possible to complete within a very short time.
- ❖ Some of the points in this book in different chapters are not possible describe briefly as these were not available.
- ❖ The whole process is not possible to attach in such a moderate frame in this report. Hence our effort to spent on summarizing them.

## **Conclusion**

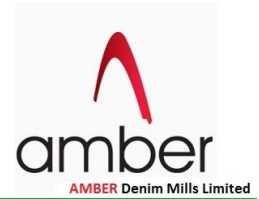
By the grace of the Almighty ALLAH, we have completed our industrial report successfully. Industrial attachment teaches us an experience that what is going to be our destiny in practical life. Amber Textiles are considered as a “very good reputations” for its best performance over many other export oriented denim textile mills.

During our training period, talking with different people of this mill we knew that the mill is fulfilling the country’s best export oriented finished denim fabric as well as very good quality fabric due to its modern machinery & very good management system.

Mill is settled with utility to give all convenient supports to the productions for twenty four hours. It had self-power generator system to satisfy total power consumptions of the mill.

We are enough lucky that we have got an opportunity of doing internship in this mill. During the training period we have received co-operation and association from the authority full & found all man, machines & materials on appreciable working condition. All stuffs & officers were very sincere to their work & devoted their duties to achieve their goal everyday & every hour.

Finally I would like to wish thanks every person of Amber Denim Mills Limited & thanks to administration of Amber Denim Mills Limited for their cordial attitude to us & supporting us in every section & teaches us different things a lot.



## References:

1. <http://www.partexholdings.com/index.html>
2. <http://www.amberdenim.com/>
3. <https://www.metrodyeing.com/dyeing/washing>
4. <http://morrisonetextmach.com/welcome.cfm>
5. <http://www.denimsandjeans.com/>
6. <http://articles.fibre2fashion.com/>
7. <http://www.picanol.be/PICBESITE/EN/>
8. <http://www.textilelearner.blogspot.com/>
9. [http://www.cibitex.it/\\_eng/home.asp](http://www.cibitex.it/_eng/home.asp)
10. [http://www.sttm.com.tw/e\\_index2.html](http://www.sttm.com.tw/e_index2.html)
11. <http://www.ngaishinhk.com/english/products/industrialWashing.htm>
12. [http://www.mechmar.com.my/products\\_as.htm](http://www.mechmar.com.my/products_as.htm)
13. <http://www.dresserwaukesha.com/index.cfm/go/list-prodsubline/productline/gascompression-engine/>
14. [http://us.kaeser.com/Products\\_and\\_Solutions/Compressed-air-treatment/default.asp](http://us.kaeser.com/Products_and_Solutions/Compressed-air-treatment/default.asp)
15. [http://www.lsacondition.com/lsgonjo\\_eng/default.asp](http://www.lsacondition.com/lsgonjo_eng/default.asp)
16. <http://spacco.com/documents/25.html>
17. <http://www.aesa-ae.com/en/textile-air-engineering/>