

# **An Internship Report on Diesel Power Plant Of Liz Fashion Industry Limited.**

**SUBMITTED BY**

**Md.Jafroul Hasan**

ID: 161-33-267

&

**Khalilur Rahman**

ID:171-33-382

An Internship Report submitted in partial fulfillment of the requirements for the award of Degree of Bachelor of Science in Electrical and Electronic Engineering.

**Supervised by**

**Md. AshrafulHaque**

*Assistant Professor*

*Department of Electrical & Electronic Engineering (EEE)*



**DEPARTMENT OF ELECTRICAL AND ELECTRONIC ENGINEERING  
FACULTY OF ENGINEERING  
DAFFODIL INTERNATIONAL UNIVERSITY**

Page-i

## **APPROVAL LETTER**

This Internship report titled “**Study on Diesel Power Plant of Liz Fashion Industry Limited**”, submitted by Md.Jafroul Hasan, ID: 161-33-267&Khalilur Rahman, ID: 171-33-382 to the Department of Electrical and Electronic Engineering, Daffodil International University has been recognized as a partial supplement to the postgraduate science phase of electrical and electronic engineering and confirmed as its style and material. The presentation has been held on..... 2020.

Board of Examiners:

## **DECLARATION**

We declare that this internship report is based on the received results. The work materials found by other researchers are referred by reference. This internship report is submitted to Daffodil International University for achieving B.Sc. degree of Electrical and electronics engineering. This internship report has not been fully submitted for any degree prior to the degree.

**Supervised by:**

**Submitted by:**

**Supervised By**

**Md. AshrafuHaque**

**Assistant Professor**

Department of Electrical & Electronic Engineering  
Daffodil International University

**Submitted By**

-----

Md.Jafroul Hasan

ID: 161-33-267

Department of Electrical & Electronic Engineering  
Daffodil International University

Khalilur Rahman

ID:171-33-382

Department of Electrical & Electronic Engineering  
Daffodil International University

## ACKNOWLEDGEMENT

WeI will be compelled forever to the Daffodil International University, Bangladesh, Electrical Engineering Department for the degree to finish this endeavor, which is my B.T. The internship report is a major part of the program. My sincere gratitude to my efforts, Md. AshrafulHaque, Assistant Professor of Department of Electrical and Electronic Engineering. Daffodil International University has made it a compulsory effort for its practical initiative. It was his bearing and unending motivation over the range of vulnerabilities and questions. We must have really expressed gratitude The speaker of Md. AshrafulHaquedivision of Electrical Engineering will express his support and support for his course. We are moreover grateful to the assets of the Electrical Engineering Department for offering their obliging hands over the range of our endeavor.

Taking everything into account, We have to perceive the responsibilities of our people, relatives, and our associates for their relentless and perpetual motivation.

# Table of Contents

<b>APPROVAL LETTER</b> .....	<b>ii</b>
<b>DECLARATION</b> .....	<b>iii</b>
<b>ACKNOWLEDGEMENT</b> .....	<b>iv</b>
<b>ABSTRACT</b> .....	<b>1</b>
<b>CHAPTER 1</b> .....	<b>2</b>
<b>INTRODUCTION</b> .....	<b>2</b>
1.1 Introduction.....	2
1.2 Company Overview .....	3
<b>Vision</b> .....	3
<b>Mission</b> .....	3
<b>Chapter 2</b> .....	<b>10</b>
<b>Diesel Power Plant</b> .....	<b>4</b>
2.1 Classification of internal combustion (I.C.) Engines .....	4
2.1.1 Four-stroke Diesel Engine .....	5
2.1.2 Two-stroke Diesel Engine .....	7
2.2 Layout of Diesel Power Plant .....	9
2.3 Essential Elements of Diesel Power Plant .....	10
<b>CHAPTER 3</b> .....	<b>11</b>
<b>INTERNAL COMBUSTION ENGINE COOLING METHOD</b> .....	<b>11</b>
3.1 Internal Combustion Engine Cooling Method.....	11
3.2 Lubrication.....	13
3.3 Engine Starting Methods .....	14
3.3.1 Compressed Air System: .....	15
3.3.2 Electric Starting: .....	15
3.3.3 Starting by an Auxiliary Engine: .....	15
3.4 Starting Procedure .....	15
3.5 Stopping the Engine.....	16
3.6 Starting Aids .....	16
3.7 Fuel Supply.....	16
Advantages of Diesel Power Plant .....	18
The various advantages of the diesel engine power plants are follow: .....	19
) Plant layout is simple.....	20
3.10 Applications of Diesel Power Plant.....	22

3.11 Cost of Diesel Power Plant .....	23
<b>Chapter 4 .....</b>	<b>24</b>
<b>Generation of Power .....</b>	<b>24</b>
4.1 Generator.....	24
4.1.1 Auxiliary Compartment .....	25
4.1.2 Combustion chamber .....	26
<b>Chapter 5 .....</b>	<b>27</b>
<b>Protection System.....</b>	<b>27</b>
5.1 Protection of Generator .....	27
5.1.1 Differential Protection.....	27
5.1.2 Loss of Field Excitation .....	28
5.1.3 Current Unbalance Protection .....	28
5.1.4 Over Current Protection .....	28
5.1.5 Restricted Earth Fault Protection .....	28
5.1.7 Under Voltage Trip .....	29
5.2 Protection of Transformer .....	29
5.2.1 Unit Transformer Protection Scheme .....	29
5.3 Transmission Line Protection .....	36
5.3.1 Distance Relay .....	36
5.4 Fire Safety Measures.....	36
5.5 Circuit Breakers .....	37
<b>Chapter 6 .....</b>	<b>38</b>
<b>Testing &amp; Maintenance .....</b>	<b>38</b>
6.1 Testing for Transformer .....	38
6.2 Generator Cooling System .....	39
6.2.1 Air cooling .....	340
6.2.2 Water cooling .....	34
<b>CONCLUSION .....</b>	<b>35</b>
<b>REFERENCES.....</b>	<b>36</b>

## **ABSTRACT**

This report explains about the power plant which is use the diesel engine as the prime mover. This power plant need to output electric energy. Generally, it is used for heavy duty vehicles. It can also be used for power generation, pumping of water etc. A generating station in which diesel engine is used as the prime mover for the generation of electrical energy is known as Diesel Power Plant. Diesel power plant is a non-renewable energy resource. Diesel power plants produce power in the range of 2 to 50MW. The diesel burns inside the engine and the products of this combustion act as the working fluid to produce mechanical energy. The diesel engine drives alternator which converts mechanical energy into electrical energy. As the generation cost is considerable due to high price of diesel, therefore, such power stations are only used to produce small power. Although steam power stations and hydro-electric plants are invariably used to generate bulk power at cheaper costs. Yet diesel power stations are finding favour at places where demand of power is less, sufficient quantity of coal and water is not available and the transportation facilities are inadequate. This plants are also standby sets for continuity of supply to important points such as hospitals, radio stations, cinema houses and telephone exchanges.

# CHAPTER 1

## INTRODUCTION

### 1.1 Introduction

Diesel engine power plant is suitable for small and medium outputs. It is used as central power station for smaller power supplies and as a standby plant to hydro-electric power plants and steam power plants.

The diesel power plants are commonly used where fuel prices or reliability of supply favors oil over coal, where water supply is limited, where loads are relatively small, and where electric line service is unavailable or is available at too high rates. Diesel power plants in common use have capacities up to about 5 MW.

The below figure shows various parts of an I.C. engine. The cylinder is the main body of the engine where in direct combustion of fuel takes place. The cylinder is stationary and the piston reciprocates inside it. The connecting rod transmits the force given by the piston to the crank, causing it to turn and thus convert the reciprocating motion of the piston into rotary motion of the crankshaft.

The valves may be provided

- (i) at the top or
- (ii) On the side of the engine cylinder.

The cam lifts the push rod through cam follower and the push rod actuates the rocker arm lever at one end. The other end of the rocker arm then gets depressed and that opens the valve. The valve returns to its seating by the spring after the cam has rotated. The valve stem moves in a valve guide acts as a bearing.

On a four stroke engine, the inlet and exhaust valves operate, once per cycle, i.e., in two revolutions of the crankshaft. Consequently, the cam shaft is driven by the crankshaft at exactly half its rotational speed.



## **1.2 Company Overview**

Founded in 1997, Liz Fashion Industry Limited is a prominent Chinese textile and apparel manufacturer and exporter based in Bangladesh — the second largest apparel exporting country in the world.

Equipped with modern technology and vertically integrated textile and apparel manufacturing facilities, manned by a dedicated and well-trained workforce of eighteen thousand strong, Liz Fashion provides high-quality products and services for global renowned fashion brands, exporting worldwide to Europe, North America and Australia.

### **Vision**

Liz Fashion strives to be a global leader in the textile and apparel industry by offering quality garment manufacturing, innovative products and outstanding services. We create a socially responsible organization that complies with international standards.

### **Mission**

Our mission is to drive strong synergy with our partners throughout the world who share our commitment to safe and healthy workplaces, to deliver high-quality products and services. We realize customers' expectations and improve on them continuously.

## **Chapter 2**

### **Diesel Power Plant**

#### **2.1 Classification of internal combustion (I.C.) Engines**

According to cycle of operation I.C. engines are two types:

- (i) Two-stroke cycle engine.
- (ii) Four-stroke cycle engine.

The relative advantages and disadvantages of these engines are as follows:

The working or power stroke is completed in two revolutions of the crank shaft in four stroke cycle engine whereas in two-stroke cycle engine the working stroke is completed in one revolution. Thus the power obtained from a two- stroke engine should be twice that of power obtained from four-stroke engine but due to charge loss and power needed to drive scavenge compressor the actual power obtained from a two-stroke engine is 50 to 60% more than four stroke engine. As one working stroke

- (i) Is completed for every revolution of crankshaft the turning moment on crankshaft is more uniform in case of two stroke engine and, therefore, a lighter flywheel serves the purpose.
- (ii) Two-stroke engine is lighter in weight and requires less space than a four-stroke engine of the same power. This makes it suitable for marine engines,
- (iii) In two-stroke engine the power needed to overcome-frictional resistance during suction and exhaust stroke is saved.
- (iv) In a two-stroke engine there is more noise and wear.
- (v) The consumption of lubricating oil is greater in a two stroke engine due to large amount of heat generated.
- (vi) Two-stroke engine is simple and its maintenance cost is low (vii) Scavenging is better in four-stroke engine.
- (vii) In two-stroke engine the exhaust port remains open for a very short time which results in incomplete scavenging and thus dilution of fresh charge.
- (viii) Construction of combustion chamber is better and simple in two-stroke engine.

### 2.1.1 Four-stroke Diesel Engine

If four-stroke diesel engine the four operations are completed in two revolutions of crank shaft.

The various operations are as follows:

#### A) Suction Stroke.

In this stroke in let valve (I.V.) remains open [Fig A] and exhaust valve (E.V.) remains closed. The descending piston draws in a fresh charge of air to fill the cylinder with it. The air taken in during suction stroke is nearly at atmospheric pressure. Line *ab* in the indicator diagram [Fig. B] represents this stroke.

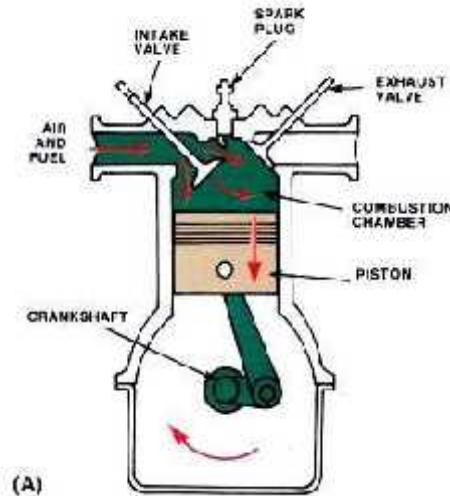

#### B) Compression Stroke.

In this stroke I.V. and E.V. remain closed. Piston moves up and the air sucked in during suction stroke is compressed to high pressure and temperature (nearly  $3.5 \text{ kg/cm}^2$  and  $600^\circ\text{C}$ ). This stroke is represented by the line *bc* in indicator diagram.

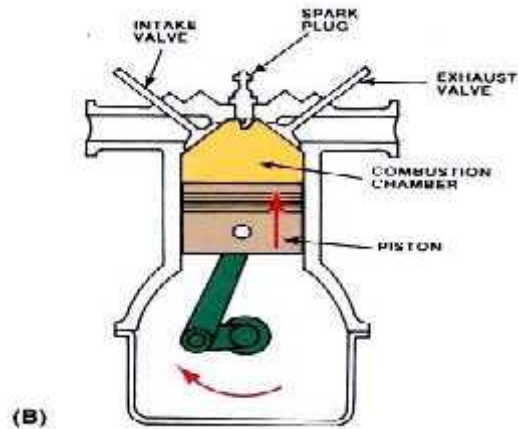

### C) Expansion Stroke:

During the stroke [Fig. C], I.V. and K.V. remain closed. Injection of fuel through the fuel valve starts Just before the beginning of this stroke. Due to compression the temperature of air inside the cylinder becomes high enough to ignite 1 ltr fuel as soon as it is injected. The fuel is admitted into the cylinder gradually in such a way that fuel burns at constant pressure.  $cd$  represents the fuel burning operation. The ignited mixture and fuel expands and forces the piston downward. Expansion stroke is represented by  $de$

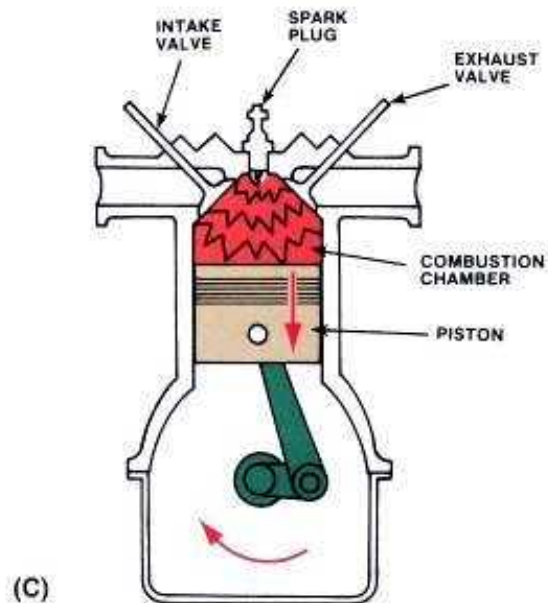

### C) Exhaust Stroke:

This stroke is represented by *ea*. In this stroke E.V. remains open, [Fig. D] and the rising piston forces the burnt gases out of cylinder.

The exhaust of gases takes place at a pressure little above the atmospheric pressure because of restricted area of exhaust passages which do not allow the gases to move out of cylinder quickly. The figure shows the valve timing diagram for a four-stroke diesel engine. The approximate crank positions are shown when I.V., E.V., and fuel valves open and close. I.D.C. represents (inner dead center) and D.C. (outer dead center), I.V.O. represents (Inlet valve opens) and V.C. represents (Inlet valve closes). Similarly, E.V.O. means exhaust valve open and E.V.C. means exhaust valve closes F.V.O. represents fuel valve opens and F.V.C. represents fuel closes and F.V.O. represents fuel valve opens.

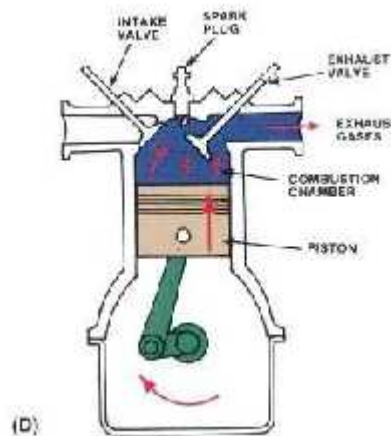

### 2.1.2 Two-stroke Diesel Engine

The various operations of a two-stroke diesel engine are shown in Figure. During the downward movement of piston (down stroke) The exhaust port is uncovered and the removal of burnt gases takes place. Further movement of the piston uncovers tin transfer port. At this stage the crank case and cylinder space are in direct communication. The slightly compressed air in the crank case is transferred to the cylinder (at a pressure of about 0.05 kg/cm<sup>2</sup> gauge) through the transfer port

While the transfer of charge from the crank case to the cylinder is taking place the removal of products of combustion is also taking place simultaneously example the incoming charge in helping in the rejection of burnt gases, this is known as scavenging. As the piston moves upward (up stroke) the compression of air starts. Near the end of compression stroke the fuel is injected and ignition of fuel is injected place due to heat of compressed air.

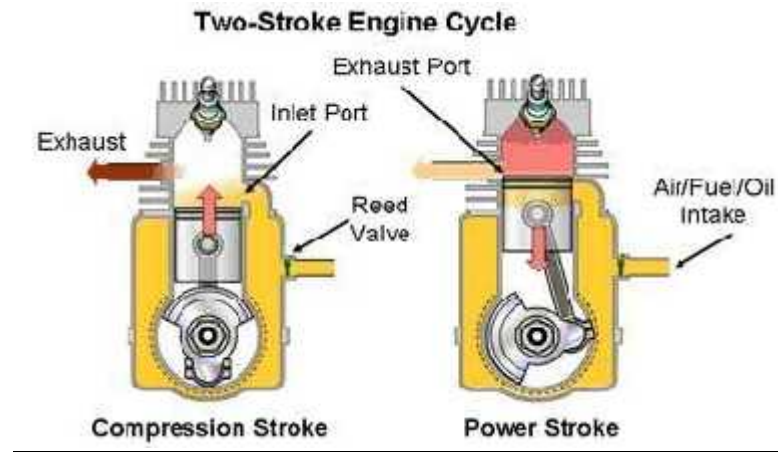

Then due to expansion of products of combustion the piston moves downward. As inlet port is uncovered a fresh charge of air gets entered in crank case. Represents constant pressure combustion line, *de* represents expansion and exhaust and scavenging are indicated by *eab*. The above figure shows valve timing diagram for two-stroke diesel engine. TDC and BDC represent top dead center and bottom dead center respectively. IPO means inlet port opens and IPC means inlet port closes, EPO represent exhaust port opens and EPS represents exhaust port closes. FAS mean fuel admission starts and FAI means fuel admission ends.

## 2.2 Layout of Diesel Power Plant

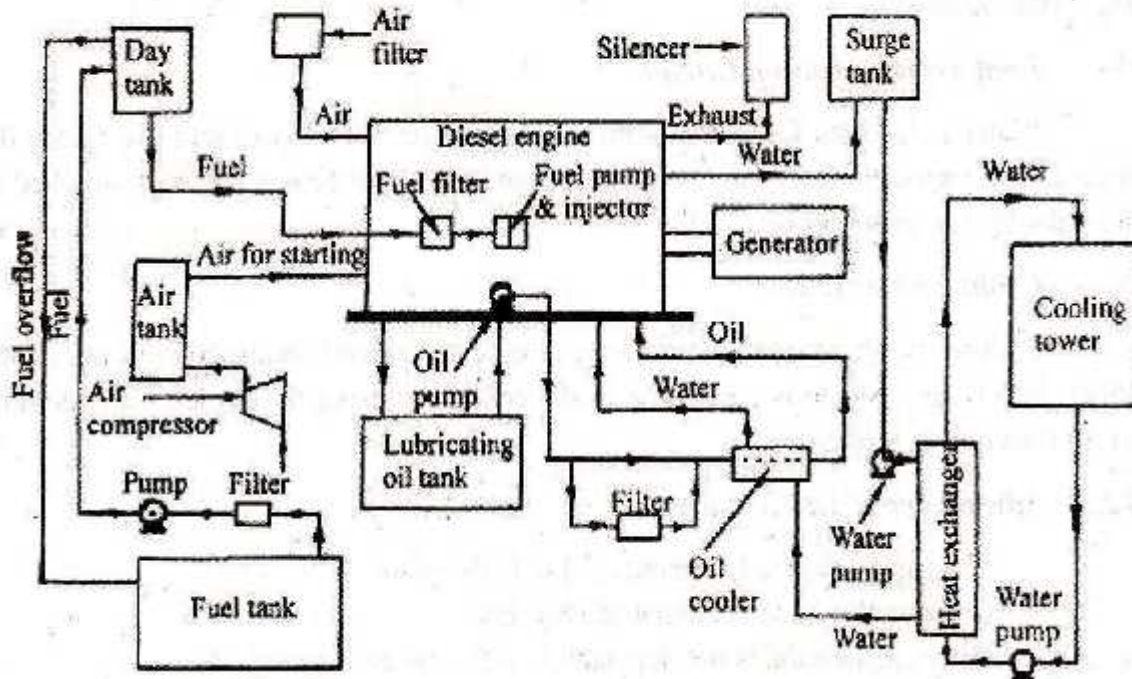

## 2.3 Essential Elements of Diesel Power Plant

Components of Diesel Engine Power plant consists of the following systems:

**Fuel supply system:** It consists of fuel tank for the storage of fuel, fuel filters and pumps to transfer and inject the fuel. The fuel ml may be supplied at the plant site by trucks, rail, road, tank, cars etc.

**Air intake and exhaust system:** It consists of pipes for the supply of air and exhaust of the gases. Filters are provided to remove dust etc. from the incoming air. In the exhaust system silencer is provided to reduce the noise.

Filters may be of dry type (made up of cloth, felt, glass, wool etc.) or oil bath type. In oil bath type of filters, the air is swept over or through a bath of oil in order that the particles of dust get coated, of the air intake systems are as follows:

- (i) To clean the air intake supply.
- (ii) To silence the intake air.
- (iii) To supply air for super charging.

The Intake system must cause a minimum pressure loss to avoid reducing engine capacity and raising the specific fuel consumption. Filters must be cleaned periodically to prevent pressure loss from clogging. Silencers must be used on some systems to reduce high velocity air noises.

**Cooling system:** This system provides a proper amount of water circulation all around the engines to keep the temperature at reasonable level. Pumps are used to discharge the water inside and the hot water leaving the jacket is cooled in cooling ponds or other devices and is recirculated again.

**Lubricating system:** Lubrication is essential to reduce friction and wear of the rubbing parts. It includes lubricating oil tank, pumps, filters and lubricating oil cooler.

**Starting system:** For the initial starting of engine the various devices used are compressed air, battery, electric motor or self-starter. Fig. 4.9 (a) shows the auxiliary equipment of diesel engine power plant.



## CHAPTER 3

### INTERNAL COMBUSTION ENGINE COOLING METHOD

#### 3.1 Internal Combustion Engine Cooling Method

There are two methods of cooling the I.C. Engines.

- a) Air cooling
- b) Water cooling.

##### 3.1.1 Air Cooling:

It is a direct method of cooling. In air cooled engine fins are cast on the cylinder head and cylinder barrel to increase its exposed surface of contact with air. Air passes over fins and carries away heat with it. Air for cooling the fins may be drawn from a blower or fan driven by the engine. Air movement relative to engine may be used to cool the engine as in case of motor cycle's engine. About 13 to 15% of heat is lost by this method. It is an air cooling system. Simplicity and lightness are the advantages but not as effective as water cooling. The rate of cooling depends upon the velocity, quantity and temperature of cooling air and size of surface being cooled.

The position of valves, Fins and head in air cooling system. This system is used in motor cycles, scooters and aero planes.

##### Water Cooling:

It is the indirect method of cooling the engine. The various cooling systems used are shown in the below figure. Water after circulating in water jackets (passages around the cylinder, combustion chamber valves etc.) goes as waste or in recirculation method of cooling water is continuously circulated through water jackets. Water takes up the heat and leaves for radiator where it is cooled for recirculation.

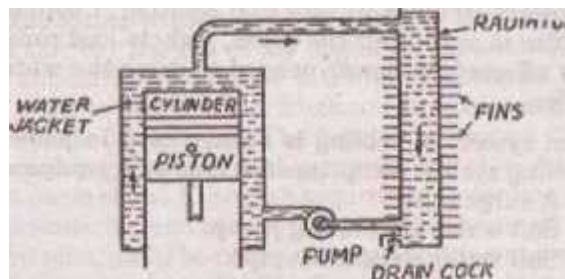

In stationary diesel engine plants the water cooling systems are as follows:

(i) **Open or Single Circuit System:**

In this system pump draws the water from cooling pond and forces it into the main engine jackets. Water after circulating through the engine return to the cooling pond.

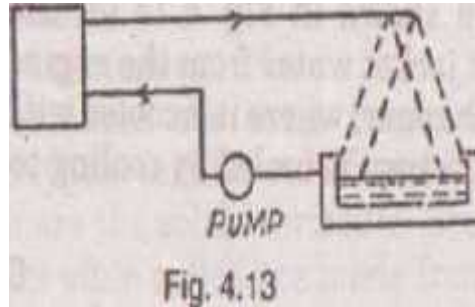

(ii) **Closed or Double Circuit System:**

In this system raw water is made to flow through the heat exchanger when it takes up the heat of jacket water and returns back to the cooling pond.

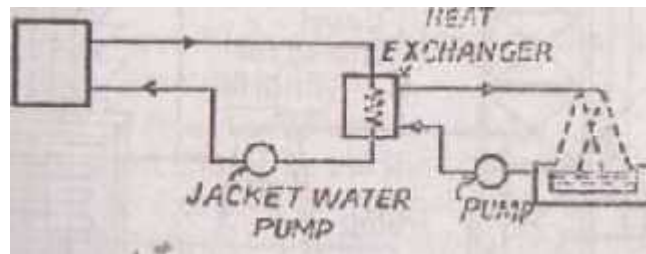

heat lost by water cooling is about 25 to 35%. The amount of heat lost is called jacket loss. The rate of flow of water should be so adjusted that the outlet temperature of cooling water does not exceed 60°C and rise in temperature of cooling water is limited to 11°C the water used for cooling purposes should be free from impurities. Water cooling methods permit uniform cooling. Water cooling creates troubles in very cold weather. Cooling efficiency is reduced due to scaling in the pipes, jackets and radiator. Engine efficiency affected by power needed to drive the water pump and radiator fan.

Closed system of cooling is mostly used in power stations. A closed cooling system comprises the following equipment.

- ) A surge tank.
- ) Soft water circulating pump.
- ) Soft water circulation pipe.

- ) Soft water heat exchanger or cooler.
- ) Raw water softening plant.
- ) Raw water circulation pump.
- ) Raw water circulation pipe.
- ) Raw water cooling arrangement such as cooling tower.
- ) Thermometer for measuring inlet and outlet temperatures.
- ) Temperature regulator to control the Excessive jacket temperature.
- ) Safety device to control the excessive jacket temperature.

This system shown is in use soft water for jack cooling. The hot jacket water from the engine is passed through cooler (heat exchanger) where it is cooled with the help of raw water.

The raw water in turn is cooled by cooling towers.

### **3.2 Lubrication**

Frictional forces cause wear and tear of rubbing parts of the engine and thereby the life of the engine is reduced. This requires that some substance should be introduced between the rubbing surfaces in order to decrease the frictional force between them. Such substance is called lubricant. The lubricant forms a thin film between the rubbing surfaces and prevents metal to metal contact. The various parts of an I.C. engine requiring lubrication are cylinder walls and pistons, big end bearing and crank pins small end bearing and gudgeon pins, main bearing cams and bearing valve tappet and guides and timing gears etc. The functions of a lubricant are as follows:

1. It reduces wear and tear of various moving parts by minimizing the force of friction and ensures smooth running of parts.
2. It helps the piston ring to seal the gases in the cylinder.
3. It removes the heat generated due to friction and keeps the parts cool.

The various lubricants used in engines are of three types:

- (i) Liquid Lubricants.
- (ii) Solid Lubricants.
- (iii) Semi-solid Lubricants.

Liquid oils lubricants are most commonly used. Liquid lubricants are of two types: (a) Mineral Oils (b) Fatty oils. Graphite, while lead and mica are the solid lubricants. Semi solid lubricants or greases as they are often called are made from mineral oils and fatty oils. A Good lubricant should possess the following properties:

- ) It should not change its state with change in temperature.
- ) It should maintain continuous films between the rubbing surfaces.
- ) It should have high specific heat so that it can remove maximum amount of heat.
- ) It should be free from corrosive acids.

The lubricant should be purified before it enters the engine. It should be free from dust, moisture, metallic chips, etc. The lubricating oil consumed is nearly 1% of fuel consumption. The lubricating oil gets heated because of friction of moving parts and should be cooled before recirculation. The cooling water used in the engine may be used for cooling the lubricant.

Nearly

2.5% of heat of fuel is dissipated as heat which is removed by the Lubrication oil.

Lubricating oil is purified by following four methods :

- (i) Settling,
- (ii) Centrifuging,
- (iii) Filtering,
- (iv) Chemical reclaiming.

The centrifuging widely used gives excellent purification when properly done.

The figure shows the lubricating oil external circuit.

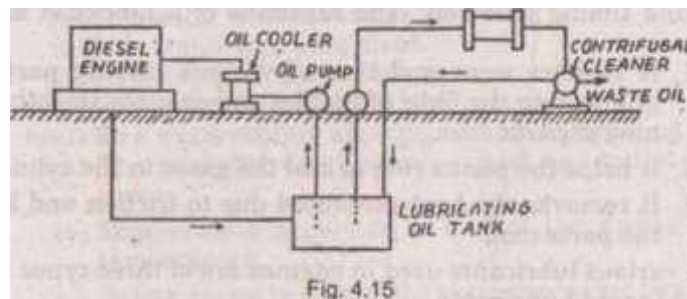

Fig. 4.15

### 3.3 Engine Starting Methods

Spark ignition engines (Petrol engines) are used mainly in smaller size where compression ratio to be overcome in cranking is only 5 to 7. Hand and electric motor (6 - 12 V, d - C) cranking are practical. Diesel engines are difficult to be started by hand cranking because of high compression required and therefore mechanical cranking system is used.

The various methods used for the starting of diesel engine are as follows:

### **3.3.1 Compressed Air System:**

Compressed air system is used to start large diesel engines. In this system compressed air at a pressure of about 20 kg per sq. cm is supplied from an air bottle I" the engine an inlet valve through the distributor or through inlet manifold. In a multi-cylinder engine compressed air er.ers mm cylinder and forces down the piston to turn the engine shall meanwhile the suction stroke of some other cylinder takes place .mi the compressed air again pushes the piston of this cylinder .mil causes the engine crank shaft assembly to rotate. Gradually the engine gains momentum and by supplying fuel the engine will Mart running.

### **3.3.2 Electric Starting:**

Electric starting arrangement consists of an electric motor which a drives pinion which engages a toothed 11 on engine flywheel. Electric power supply for the motor is made available by a small electric generator driven from the engine in case of small plants a storage battery of 12 to 36 volts is used to supply power to the electric motor.

The electric motor disengages ' automatically after the engine has started. The advantages of electric starting are its simplicity and effectiveness.

### **3.3.3 Starting by an Auxiliary Engine:**

In this method a small petrol engine is connected to the main engine through clutch and gear arrangements. Firstly, the clutch is disengaged and petrol engine is started by hand. Then clutch is gradually engaged and the main engine is cranked for starting. Automatic disengagement of clutch takes place after the main engine has started.

## **3.4 Starting Procedure**

Actual process of starting the engine differs from engine to engine. Some common steps for starting the engine are as follows:

1. Before starting the engine, it is desirable to check fuel system, lubricating system and cooling water supply.
2. Depending upon the method of starting a check for the same is essential. If air starting is used the pressure of air should be checked and also the air system should be checked for possible leakage. The storage battery should be checked if electric motor is used for starting.

3. There should be no load on the engine.
4. Crank the engine and run it at slow speed for a few minutes and again check the working of various systems such as fuel, lubricating oil system etc.

The speed of the engine should be gradually increased till it synchronizes with the bus bars. Then connect the generator to the bus and finally increase the engine speed so that it takes up desired load.

### **3.5 Stopping the Engine**

The engine should not be stopped abruptly. To stop the engine the speed should be decreased gradually until no power is delivered by the alternator. Then the engine is disconnected from the bus bars and is allowed to run idle for some time.

### **3.6 Starting Aids**

Starting aids may be used during cold weather to obtain quicker starting of the engine. Ethyl ether is mostly used as such aid. Glow plugs another starting aid. Glow plug forms a local hot spot thus imitating the combustion of fuel even if the compression temperature of air is insufficient.

### **3.7 Fuel Supply**

The fuels used in I.C. engines are in liquid form. They are preferred because of their high calorific value and ease of storage and handling. The storage of oil fuel is simpler than the solid fuel. The amount of fuel to be stored depends upon the service hours unit vary for different installations. Bulk storage and engine day tanks hold the engine fuel. The fuel delivered to the power plant is received in storage tanks. Pumps draw the oil from storage tanks and supply it to the smaller day tanks from where the oil is supplied to the engine as shown in figure.

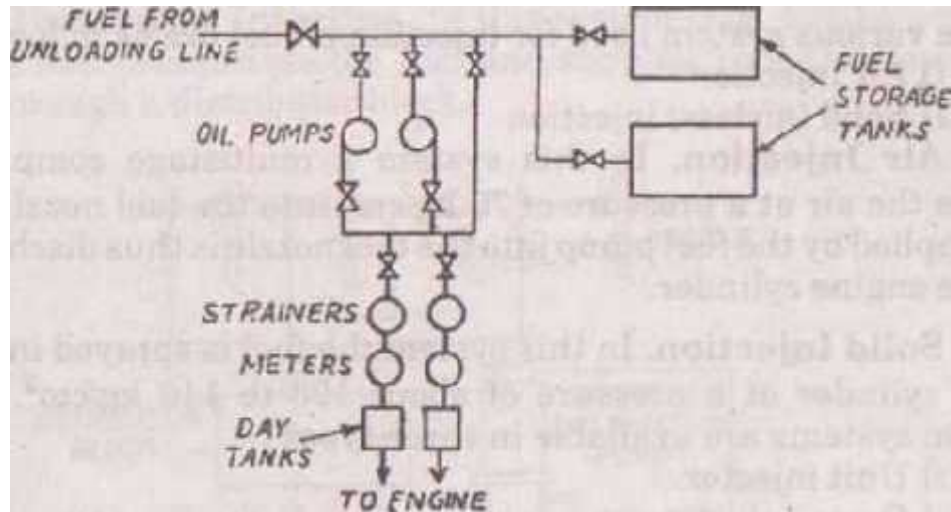

The fuel oil used should be free from impurities. Efforts should be made to prevent contamination of the fuel. An important step is to reduce the number of times the fuel is handled. Greater amount of impurities settles down in the storage tank and remaining impurities are removed by passing the oil through filters. Storage tank may be located above the ground or underground. But underground storage tanks are preferred. Fig. 4.17 shows an underground storage tank. It is provided with coils, heated by steam or hot water to reduce viscosity and to lower the pumping cost. Main hole is provided for internal access and repair. Vent pipe is provided to allow the tank to breathe as it is filled or emptied. Level indicator measures the quantity of oil in the tank, and an overflow line is provided to control the quantity of oil.

### 3.8 Diesel Engine Fuel Injection System

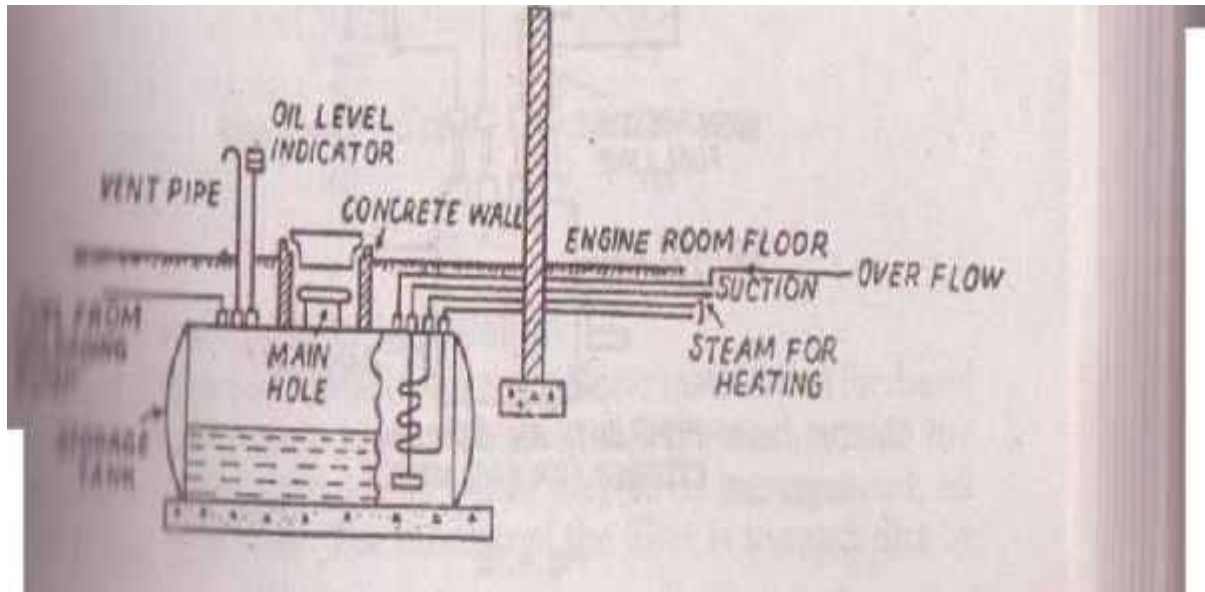

The fuel injection system should be such that adequate quantity of fuel oil is measured by it, atomised, injected and mixed with the fuel oil because even the smallest particles of dirt can completely damage the fuel injection system. The various systems used for injection of fuel are as follows:

- (i) Air injection
- (ii) Solid (airless) injection

#### 3.8.1 Air Injection:

In this system a multistage compressor delivers the air at a pressure of  $70 \text{ kg/cm}^2$  into the fuel nozzle. The fuel supplied by the fuel pump into the fuel nozzle is thus discharged into the engine cylinder.

#### 3.8.2 Solid Injection:

In this system the fuel is sprayed into the engine cylinder at a pressure of about 100 to 140  $\text{kg/cm}^2$ . Solid injection systems are available in three types:

- ) Unit injector.
- ) Distributor injection



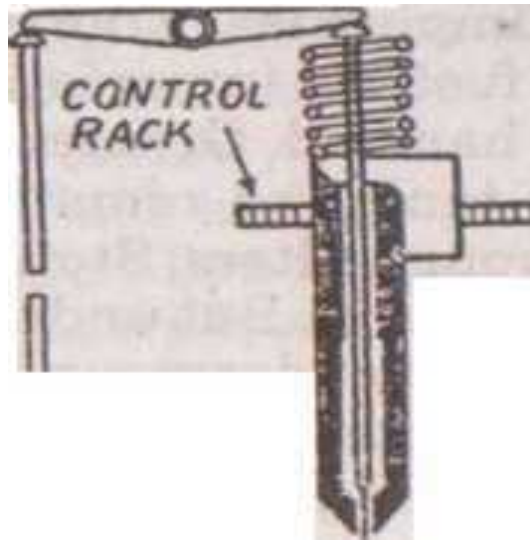

### 3.8.2 Unit Injector:

In this system a pump plunger is actuated by a cam through a push rod and rocker arm mechanism. The plunger moving in a barrel raises the pressure of fuel oil meters the quantity of fuel and controls the injection timing. There is a oring loaded delivery valve in the nozzle. This valve is actuated by the change in fuel oil pressure

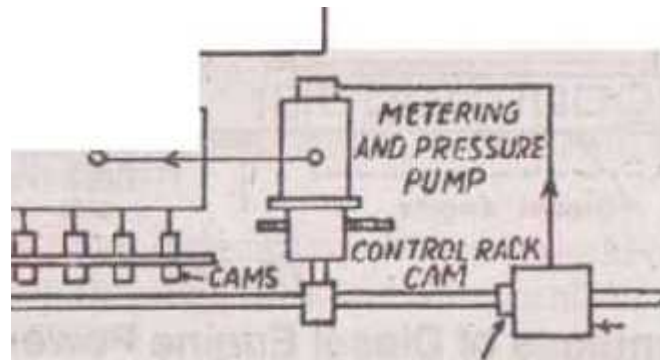

### 3.8.3 Pump Injection:

In this system individual pump is provided for each nozzle. The pump measures the fuel charge and controls the injection timing

### 3.8.4 Distributor Injection.

In this system (Fig. 4.20) a pump measures and pressurizes the fuel and supplies to it the various nozzles through a distributor block.

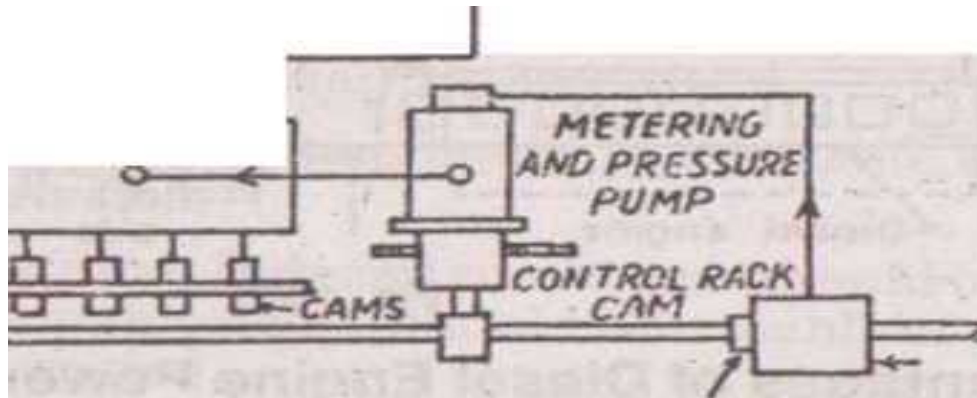

Fuel injection takes place through very fine holes in the nozzle body. There are several types of fuel injection nozzles. Two common types are fuel injection nozzle and pintle nozzle. In multihole nozzle each spray orifice produces a dense and compact spray. In pintle nozzle, fuel

A typical filter and silencer installation for diesel the air system begins with an intake located outside the building provided with a filter which may be oil impingement, oil path type filter. The function of the filter is to catch dirt by causing it to cling to the surface of filter material. A silencer is provided between the engine and intake.

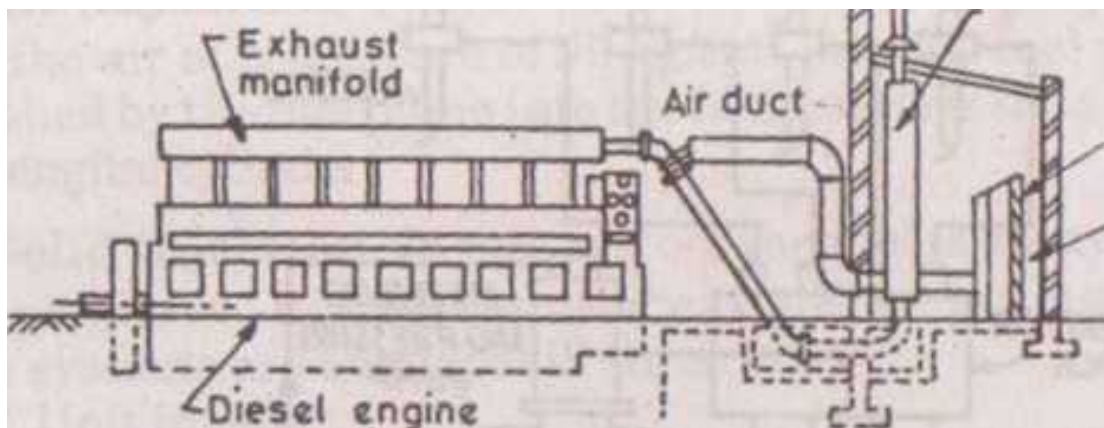

### **Advantages of Diesel Power Plant**

The various advantages of the diesel engine power plants are follow:

- ) Plant layout is simple.
- ) It is easy to designing and install
- ) In this plant handling of fuel is easier. Small storage space for fuel is required, there is no refuse to be disposed of and oil needed can be easily transported.
- ) It can be located near load centre.
- ) A diesel engine extracts more useful work from each heat unit than other types of I.C. engines. Therefore, it becomes an attractive prime mover wherever first cost in written off and operating cost is important.
- ) The plant can be quickly started and can pick up load in very short time.
- ) There are no standby losses.
- ) It does not require large amount of water for cooling
- ) The plant is smaller in size than steam power plant for the same capacity.
- ) The operation of the plant is easy and less labour is needed to operate the plant.
- ) Compared to steam power plant using steam turbine, the life of diesel power plant is longer.
- ) Diesel engines operate at higher thermal efficiency than compared to steam power plants.

### **Disadvantages of Diesel Power Plant**

1. The plant does not work satisfactorily under overload conditions for longer times.
2. Lubrication cost is high.
3. The capacity of plant is limited & the capacity of plant is limited.

### 3.9 Site Selection

While selection the site for diesel engine power plant the following factors should be considered:

- ➔ **Distance from load centre:** The plant should be located near the load centre. This will minimize the cost of transmission lines, the maintenance and power losses through them.
- ➔ **Availability of water:** Water should be available in sufficient quantity at the site selected.
- ➔ **Foundation condition:** Sub-soil conditions should be such that Inundation at a reasonable depth should be capable of providing a strong support to the engine.
- ➔ **Fuel transportation:** The site selected should be near to the source of fuel supply so that transportation charges are low.
- ➔ **Access to site:** The site selected should have road and rail transportation facilities.
- ➔ The site selected should be away from the town so that the smoke and other gases coming out of the chimneys do not affect the Inhabitants.

### 3.10 Applications of Diesel Power Plant

1. They are quite suitable for mobile power generation and are widely used in transportation systems consisting of rail roads, ships, automobiles and aero planes.
2. They can be used for electrical power generation in capacities from 100 to 5000 H.P.
3. They can be used as standby power plants.
4. They can be used as peak load plants for some other types of power plants.
5. Industrial concerns where power requirement are small say of the order of 500 kW, diesel power plants become more economical due to their higher overall efficiency. Diesel power plant is quite suitable at places where-
  - (i) Fuel prices or reliability of fuel supply favour oil over coal,
  - (ii) Water supply is limited.
  - (iii) Loads are relatively small.
  - (iv) Power from other power plants such as steam, hydro power plants etc. is not available or is available at too high rates.

### **3.11 Cost of Diesel Power Plant**

Cost of any power plant changes rapidly when there are inflationary trends in the nation's currency and cost becomes out-of-date far more rapidly than technical information. A diesel engine power plant may cost about Rs. 1500 to Rs. 2000/kW of capacity. The major part of the cost in diesel engine power plant is that of engine generator set. Approximate sub-division of investment cost in various items may be as follows:

#### **3.11.1 Plant Maintenance**

Diesel engine power plant maintenance depends on factors. Careful supervision of the equipment used for recording temperature pressure and electrical data are essential the temperature inside the engine should not be allowed to exceed the safe limits as diesel engine is an all metal machine and there is no refractory protection. The temperature, flow and quality of fuel oil should be checked from time to time. The fuel oil must be cleaned from dirt and other impurities by means of filters. Filters may have fiber element, or cloth or fiber or a combination of cloth and fiber. When filter element becomes choke it should be replaced by a new one. Dirt in fuel oil ruins the fine lap of fuel injection pumps plugs the injection nozzle orifice. Occasionally, all the fuel be drained and the fuel tank cleaned thoroughly. The temperature and flow of coolant, lubricating oil and exhaust gases should be checked at regular interval.

# Chapter 4

## Generation of Power

In LIZ FASHION INDUSTRY , the whole electricity generation process works as follows. At first, Diesel comes from TitasDiesel Company Ltd. Then the Diesel is passed through scrubber to Diesel Booster Compressor. Later on, the Diesel is filtered with fine filter and filter separator. Next, the Diesel is sent to Diesel valve module. Afterwards, the Diesel is sent into combustion chamber.

In combustion chamber the Diesel is mixed with air. Then firing is made. When the rotor speed goes 3000 rpm, then it is synchronized. As a result, we get 440V generator output voltage.

### 4.1 Generator

In LIZ FASHION INDUSTRY, there is actually two large generator units each of which produces 2 MW power as the plant's name describes. This means that the units consist of various other machines and motors other than only generators. And during our internship, we got to see and told thoroughly about what these units consist of and how they work. We will try to describe that experience here in this section [13].

**(a) Auxiliary compartment which contains -**

- ) Lube oil Pump
- ) Cranking Motor
- ) GT starting Motor
- ) Turning Gear

**(b) Combustion Chamber which contains –**

- ) 14 Combustion Liners
- ) 3 different nozzles

**(c) Diesel excitation compartment which contains -**

- ) 17 stage compressors
- ) Combustion system
- ) 3 stage Turbine

### **4.1.1 Auxiliary Compartment**

In auxiliary compartment the steps of working process is as follows.

- At first after getting starting command, cranking motor starts within 15-30 secs with the help of Lube oil pressure, Hydraulic oil pressure and Lift oil pressure.
- Then the turbine starts to speed-up and reaches 600 RPM. Afterwards, it decreases and reaches up to 360 RPM when firing occurs from Burner.
- Afterwards, the turbine RPM starts increasing again and reaches up to 3000 RPM when the excitation gets on. Thus, the turbine gets synchronized.



Figure 4.1: Combustion Chamber Compartment of liz fashion industry

### **4.1.2 Combustion chamber**

In combustion chamber compartment, we were told about how the combustion process works. Here the filtered air is mixed with Diesel and burned with the help of spark plug. Compressed Diesel is supplied to each combustion chamber through a nozzle that functions to disperse and mix the compressed Diesel with proper amount of combustion air. In LIZ FASHION INDUSTRY, there are in total 14 combustion chambers within a unit. Each combustion chamber has three nozzles attached to it. They are primary nozzles, secondary nozzles and cap-liners. All these nozzles with a combustion chamber are pointed out [6].

The main components of combustion chamber are as follows –

- Spark Plug: 14 Nos
- Primary Fuel Nozzle: 14 Nos
- Secondary Fuel Nozzle: 14 Nos



## **Chapter 5**

### **Protection System**

LIZ FASHION INDUSTRY is a Diesel Power Plant with turbine, boiler, compressor, combustion chamber, Diesel booster, water treatment plant and various pipes, valves and fans. And these are the major part of the electricity generation process. Hence, LIZ FASHION INDUSTRY authority has the necessary and proper Protection System for the safety of this equipment and apparatus. In this chapter, a brief overview and discussion on the Protection system of LIZ FASHION INDUSTRY will be made.

#### **5.1 Protection of Generator**

Just like any other power plants, LIZ FASHION INDUSTRY has many generator protections included among which some major and important ones that we were told about are discussed below. Here to mention that the description of the mentioned protections will be made based on collective perspective and theoretical knowledge as this is impossible to see these protection systems live because of their internal connections [14] [15].

- ) Differential Protection.
- ) Loss of Field or Excitation Protection.
- ) Current Unbalance Protection.
- ) Over Current Protection.
- ) Restricted Earth Fault Protection.
- ) Over Voltage Protection.
- ) Reverse Power Trip.
- ) Under Voltage Trip.

Basically, these all are various kinds of relays. Now some of these relays are briefly discussed in the following segments of the chapter as below.

##### **5.1.1 Differential Protection**

From the collective perspective, we saw several differential protections for generator. It is actually a relay. It is used here in LIZ FASHION INDUSTRY to protect generator winding against internal faults such as phase-to-phase and three phase-to-ground faults [6]. We were told that the differential relay that has been used in the generator is actually current differential relay.

### **5.1.2 Loss of Field Excitation**

Loss of field excitation is a protective measure taken against the failure of AVR or field open circuit or short circuit. Due to these failure generator acts as an induction motor. So, protection against Loss of Field Excitation is very important.

### **5.1.3 Current Unbalance Protection**

From the collective perspective we know that current unbalance occurs due to difference in three phase voltage. In LIZ FASHION INDUSTRY, there is protection against this in generator. This is used because due to current imbalance, high current is induced in the rotor of generator which leads to overheating of motor and burning of windings. In fact, this is a switchgear relay that is used in LIZ FASHION INDUSTRY. This relay has also been used in LIZ FASHION INDUSTRY so as to compare the loads of various circuits [1] [15].

### **5.1.4 Over Current Protection**

In LIZ FASHION INDUSTRY, generator is designed to operate continuously at rated KVA, frequency and power factor over a range of 95% to 105% of rated value. Now, operating of the generator beyond rated KVA may result in harmful stator over current. This leads to overheating of stator and failure of insulation. This is very a risky condition for people working in the unit. Hence, such a protection is taken in LIZ FASHION INDUSTRY generator unit [16].

### **5.1.5 Restricted Earth Fault Protection**

The working function of it is similar to generator differential protection. It protects the high voltage winding of power transformer against internal faults. One set current transformer on neutral and phase side of the power transformer are exclusively used for this protection. The protection cannot detect turn-to-turn fault within one winding. Upon the detection of a phase to phase or phase to ground fault in the winding, the unit is tripped automatically from control unit in LIZ FASHION INDUSTRY.

### **5.1.6 Reverse Power Protection**

Our intern advisor introduced us to a new type of protection for generator called Reverse Power Protection. This is actually a protection for the Prime mover of the generator rather than for the whole generator. It describes a condition where the prime mover of a generator is not supplying sufficient torque to keep the generator rotor spinning at the same frequency as the grid to which the generator is connected. In other words, the generator will actually become a motor and will draw current from the grid and will be supplying torque to the prime mover which is supposed to be supplying torque to the generator. Hence a protection relay is set up by LIZ FASHION INDUSTRY within the generator prime mover [7].

### **5.1.7 Under Voltage Trip**

In LIZ FASHION INDUSTRY, there is also protection relay for under voltage occurrence. This method is used to prevent closing of the breaker by mistake. In this system tripping is generally delayed. This is done so that the voltage drop is caused by fault and time is allowed for the appropriate fuse or breaker to operate and the voltage to be recovered without the loss of power supply.

## **5.2 Protection of Transformer**

In LIZ FASHION INDUSTRY just like any other plant, it has got different types of transformers like Power transformer, Current transformer, Step-down transformers for transmission of current to grid and others. And therefore, lots of protection has been taken care of for the safety purpose here in LIZ FASHION INDUSTRY. Actually, the LIZ FASHION INDUSTRY authority installed a protection scheme as a whole for the transformer protection ever since the plant was built for easy monitoring and protection purpose. And that protection scheme is described down here briefly based on the collective perspective.

### **5.2.1 Unit Transformer Protection Scheme**

LIZ FASHION INDUSTRY has a very advanced Transformer Protection Unit designed for use on 3-phase power transformers as we observed. It provides sensitive high-speed differential protection for internal phase and ground faults as well as time and instantaneous over current protection for auto, winded transformers. The user-selectable harmonic restraint setting prevents false tripping on magnetizing inrush and over excitation. So whenever any

faults occur, protection unit trips down and take necessary steps to protect the transformers [13].

### **5.3 Transmission Line Protection**

Transmission Line protection systems are designed to identify the location of faults on the transmission line and to isolate only the faulted section. The key challenge to the transmission line protection lies in reliably detecting and isolating faults compromising the security of the system. As we were only showed the Distance relay, it is discussed below.

#### **5.3.1 Distance Relay**

From the collective perspective, distance relay work on the basis that the impedance of a transmission line is proportional to its length. For distance measurement it is appropriate to use a relay capable of measuring the impedance of a line up to a predetermined point. Such a relay is described as a distance relay and is designed to operate only for faults occurring between the relay location and the selected reach point, thus giving protection for faults that may occur in different line sections [6] [14].

### **5.4 Fire Safety Measures**

During our working period in LIZ FASHION INDUSTRY, we attained a whole day training session about Fire Fighting and Safety Procedure by a senior specialist on this field. In LIZ FASHION INDUSTRY, there is a section where large cylinders containing Carbon-Di-Oxide Diesel are set that are made inter connected by pipes with all internal sections as in Combustion chamber, Diesel booster etc. The capacity of CO<sub>2</sub> in these cylinders at LIZ FASHION INDUSTRY is 6000 Kg per tank. They are programmed such that where ever any burning or combustion occurs internally in the system; CO<sub>2</sub> directly reaches there and handle the situation automatically. For that, there are sensors used everywhere in the system off course to find out any combustion. Apart from that, routine workshop is hold for the workers and stuffs to keep them aware and cautious about dealing fire. Figure 5.1 shows the compartment where the large CO<sub>2</sub> cylinders are made connected. This compartment branches out and expands to various sections of the plant where there is the need of fire safety. It is to mention that these cylinders are changed on routine basis as they need to be refilled.



Figure 5.1: CO<sub>2</sub> fire safety cylinders for internal instrument protection in Liz Fashion Industry

## 5.5 Circuit Breakers

A circuit breaker is an automatically operated electrical switch designed to protect an electrical circuit from damage caused by overload or short circuit. Its basic function is to detect a fault condition and to immediately discontinue electrical flow. Unlike a fuse, which operates once and then has to be replaced, a circuit breaker can be reset to resume normal operation. The circuit breakers that are commonly used in different sections of the plant are as follows [11] [13],

- ) SF6 circuit breaker
- ) Air Blast Circuit Breaker (ABCB)
- ) Air break Circuit Breaker (ACB)
- ) Miniature Circuit Breaker (MCB)
- ) Molded Case Circuit Breaker (MCCB)

## **Chapter 6**

### **Testing & Maintenance**

In every plant there are lots of elements that need to be tested in a routine basis. Moreover, electrical elements need to be maintenance properly in order to make lasted for a long time. So, in LIZ FASHION INDUSTRY, there are certain testing and maintenance procedures that we were told about. A brief discussion of them is in below.

#### **6.1 Testing for Transformer**

In practical it is very important to determine the transformer reaction for different loads. The performance depending on parameters can be obtained by solving the equivalent circuit for any load conditions. Although when a transformer is rewind with different primary and secondary windings the equivalent circuit also changes. In order to get the equivalent circuit parameters, test methods are first choice. From the analysis of the equivalent circuit one can determine the electrical parameters. On the other hand if the temperature rise of the transformer is required, then test method is the most dependable way. There are several tests that are done on the transformer in LIZ FASHION INDUSTRY . A few common ones are discussed here [10] [13].

##### *6.1.1 Transformer Oil test*

An oil sample will identify many things on a transformer. The following tests can be performed with the oil sample.

###### *6.1.1.1 Acid Neutralization Test*

The Acid Neutralization test is a test of the fluid that declares of how much it has oxidized. Oxidization decreases its dielectric property. Acidity shows chemical reaction with organic insulation. Oxidized fluid will allow interior components to rust.

### 6.1.1.2 Dielectric Breakdown Test

Dielectric strength of insulating oil is measured in this test. In LIZ FASHION INDUSTRY , they have Dielectric strength measuring machine manufactured by Megger to test the oil. The transparent glass part, there are two electrodes placed at a distance. The test is done by applying an AC voltage between the electrodes. The gap between the electrodes is specified. There is a digital keypad with a display on the right side of the machine. This keypad is used to apply the voltage right before the insulation breaks down, so that a conducting path is formed. Then the dielectric strength is calibrated from the specified distance and the applied voltage. If the dielectric strength is decreased, then the arc extinguishing capacity will be decreased. Here it is important to mention that the module is strictly monitored and controlled by engineers due to its delicacy.

### 6.1.1.3 Moisture Content Test

Water decreases the power of insulation of oil. Moist can be formed from two sources. One of them is by the breathing process or from oil degradation. Now to absorb the moisture in the air sucked in by the transformer during the breathing process, silica gel breather is used. Now a question may rise that what is transformer breathing. Well when load on transformer increases the insulating oil of the transformer gets heated up, expands and gets expelled out in to the conservator tank present at the top of the power transformer and subsequently pushes the dry air out of the conservator tank through the silica gel breather [9]. This process is called breathing out of the transformer. Oil degradation also produces moisture.

## 6.2 Generator Cooling System

Generator is heated up while running. Too much heat built in generator is not allowed. Excessive heat reduces the performance and its lifetime. In LIZ FASHION INDUSTRY there is cooling system installed with generator. In the following section, generator cooling system will be discussed.

### **6.2.1 Air cooling**

In LIZ FASHION INDUSTRY, air cooling method is used to cool the generator. Air is passed through the generator to dissipate the heat. The air around the generator is hot. So passing cool air replaces the hot air around generator and eventually the temperature falls down.

### **6.2.2 Water cooling**

Water fins are surrounded by the generator to absorb heat and then carrying the heat away. Water is being flown continuously by a motor and the heat is being dissipated away. At the LIZ FASHION INDUSTRY, they use water cooling system to cool down the generator.



## CONCLUSION

Diesel engines provide durable, reliable energy to meet both mobile and stationary power needs. The diesel plant has been designed and constructed. Also it has been started and run efficiently. It produces power in the range of 2 to 50MW. Diesel engine power plant is suitable for small and medium outputs. Since Diesel engine power plant is suitable for small and medium outputs, it produces power to central power station for smaller power supplies and as a standby plant to hydro-electric power plants and steam power plants. The diesel engine drives alternator which converts mechanical energy into electrical energy. Although steam power stations and hydro-electric plants are invariably used to generate bulk power at cheaper costs. Yet diesel power stations are finding favor at places where demand of power is less, sufficient quantity of coal and water is not available and the transportation facilities are inadequate. These plants are also standby sets for continuity of supply to important points such as hospitals, radio stations, cinema houses and telephone exchanges. Only backup generators powered by diesel fuel can provide the features of quick start-up time, power density/fuel efficiency, continuous strength, disaster utility, reliability, availability, portability and durability.

## References

Chowdhury, Tanvir, Shobnom Sultana, and Md Hassan. *Demonstration and Practical Visit of Power Generation, Power Transmission and Power Distribution System of BPDB Rajshahi*. Diss. East West University, 2018.

Chisim, Jenifer Jue, ShafinAkter, and NasrinAkter. *Combined Cycle Power Plant and Substation of Ashuganj Power Station Company Limited (APSCL)*. Diss. East West University, 2012.

Chisim, J. J., Akter, S., & Akter, N. (2012). *Combined Cycle Power Plant and Substation of Ashuganj Power Station Company Limited (APSCL)* (Doctoral dissertation, East West University).

Wies, R. W., Johnson, R. A., Agrawal, A. N., & Chubb, T. J. (2005). Simulink model for economic analysis and environmental impacts of a PV with diesel-battery system for remote villages. *IEEE Transactions on Power Systems*, 20(2), 692-700.