

DIGITAL TO-LET SYSTEM

BY

NIJHUM SULTANA

ID: 171-35-1981

This Report Presented in Partial Fulfillment of the Requirements for the Degree of
Bachelor of Software Engineering.

Supervised By

Mr. Farhan Anan Himu

Lecturer

Department of Software Engineering

Daffodil International University



DAFFODIL INTERNATIONAL UNIVERSITY

DHAKA, BANGLADESH

Fall – 2020

APPROVAL

This Project titled as “**Digital To-let System**”, submitted by **Nijhum Sultana** to the Department of Software Engineering, Daffodil International University, has been accepted as satisfactory for the partial fulfillment of the requirements for the degree of B.Sc. in Software Engineering and approved as to its style and contents.

BOARD OF EXAMINERS

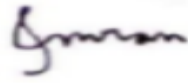

Chairman

Dr. Imran Mahmud
Associate Professor and Head
Department of Software Engineering
Faculty of Science and Information Technology
Daffodil International University



Internal Examiner 1

Dr. Md. Mostafijur Rahman
Associate Professor
Department of Software Engineering
Faculty of Science and Information Technology
Daffodil International University

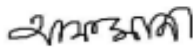

Internal Examiner 2

Afsana Begum
Lecturer (Senior)
Department of Software Engineering
Faculty of Science and Information Technology
Daffodil International University

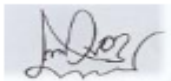

External Examiner

Professor Dr. Mohammed Nasir Uddin
Professor and Chairman
Department of Computer Science and Engineering
Jagannath University

DECLARATION

I, hereby state that, I have taken this project under the supervision of **Mr. Farhan Anan Himu Lecturer, Department of Software Engineering, Daffodil International University**. I also state that I have submitted neither this project nor any part of it for award of any degree.

Supervised by:

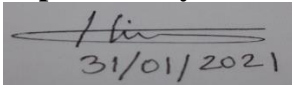

Mr. Farhan Anan Himu

Lecturer

Department of Software Engineering
Faculty of Science and Information Technology
Daffodil International University

Submitted by:

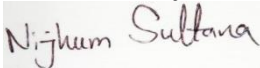

Nijhum Sultana

ID: 171-35-1981

Batch: 22nd

Department of Software Engineering
Faculty of Science and Information Technology
Daffodil International University

ACKNOWLEDGEMENT

I express my heartiest thanks and gratefulness to Almighty Allah for his divine blessing makes me possible to complete this project successfully.

I am grateful and wish my profound and indebtedness to **Mr. Farhan Anan Himu, Lecturer**, Department of SWE, Daffodil International University, Dhaka. Deep Knowledge and keen interest of my supervisor in the field of Web Programming to carry out this project. His endless patience, scholarly guidance, continual encouragement, constant and energetic supervision, constructive criticism, valuable advice, reading many inferior drafts and correcting them at all stages have made it possible to complete this project.

I would like to express my heartiest gratitude to **Dr. Imran Mahmud, Associate Professor and Head of Department**, Department of SWE, for his kind help to finish our project and also to other faculty members and the staffs of SWE department of Daffodil International University.

I would like to thank my entire course mates in Daffodil International University, who took part in this discuss while completing the course work.

Finally, I must acknowledge with due respect the constant support and patience of my parents.

EXECUTIVE SUMMARY

The “**Digital To-Let System**” is a web-based project that will help the general people for the sake of searching rented home/seat/sublet. The development process of “**Digital To-Let System**” is started from December, 2020. I had to think about a relevant problem regarding to our accommodation sector. Then I have tried my level best to think as an end user and polish my base idea and make it much detailed as possible. This documentation is the final result of that base idea.

The main purpose of “**Digital To-Let System**” is described in the first chapter. By going through it, one can understand the project Overview, Background, Goals and Benefits of the project. It also introduces the Stakeholders of the project. One can also get rough idea by going through the system model in this section.

The second chapter contains all the requirements of the stakeholders. These requirements were needed to be fulfilled by the system. These are mainly the functional requirements and non-functional requirements.

The third chapter contains the system analysis part. This part will describe the Use Case Diagram with description, Activity Diagram and Sequence Diagram. This part is based on analysis.

The fourth chapter contains the Development Tools and Technology. One can also find the Entity Relationship Diagram and Class Diagram.

The fifth chapter has system test case. Because developing is not the end of the project. It has to work perfectly before we can call it a functional project. For this, we have to make sure the quality of the product by undergoing various test cases.

We all know that, the User manual acts as a guide for the user. It helps them to get easily interact with the system. It contains all the information on how the system can be used properly and get information through the system. The sixth chapter will define briefly as much as possible.

The last chapter lists the conclusion part including GitHub Link, Project Summary, Limitations and Future Scope. I also included the list of all the resources as references that helped me to complete my project here.

Table of Contents

APPROVAL.....	i
DECLARATION.....	ii
ACKNOWLEDGEMENT	iii
EXECUTIVE SUMMARY.....	iv
Table of Contents	vi
Lists of Figures and Tables	xii
CHAPTER 1.....	1
INTRODUCTION	1
1.1 Project Overview	1
1.2 Project Purpose.....	2
1.2.1 Background	2
1.2.2 Benefits and Beneficiaries	2
1.2.3 Goals.....	3
1.3 Stakeholders	4
1.3.1 Owner	4
1.3.2 Tenant	4
1.3.3 Guest.....	4
1.3.4 Admin	4
1.4 System model for Digital To-Let System.....	5
CHAPTER 2.....	6
SOFTWARE REQUIREMENT SPECIFICATION (SRS)	6
2.1 Functional Requirements	6
2.1.1 Registration for users.....	8
2.1.2 Login for authenticate users.....	8
2.1.3 Logout for authenticate users.....	9
2.1.4 Can create property post	9
2.1.5 Can view property posts	9
2.1.6 Can update property posts.....	9
2.1.7 Can delete property posts.....	10
2.1.8 Can view necessity posts	10
2.1.9 Property search by location.....	10
2.1.10 Property search by amount	10
2.1.11 Can create necessity posts.....	11

2.1.12	Can update necessity posts	11
2.1.13	Can delete necessity posts.....	11
2.1.14	Can view Area Guide	11
2.1.15	Can view Blog.....	12
2.1.16	Can add Area Guide	12
2.1.17	Can edit Area Guide	12
2.1.18	Can delete Area Guide.....	12
2.1.19	Can add Blog.....	13
2.1.20	Can edit Blog	13
2.1.21	Can delete Blog.....	13
2.1.22	Contact with system admin.....	13
2.1.23	Retrieve password by email.....	14
2.2	Performance Requirements	14
2.2.1	Speed and latency Requirements	14
2.2.3	Capacity Requirements.....	15
2.3	Dependability Requirements.....	15
2.3.1	Reliability Requirements	16
2.3.2	Availability Requirements	16
2.3.3	Maintainability Requirements.....	16
2.4	Security System Requirements	16
2.5	Usability and Human-Interaction Requirements.....	17
2.5.1	Ease of Use Requirements	17
2.5.2	Understand Ability and Politeness Requirements.....	17
2.5.3	Accessibility Requirements	18
2.5.4	User Documentation Requirements.....	18
2.6	Training Requirements.....	18
2.7	Look and Feel Requirements	18
2.7.1	Appearance Requirements	19
2.7.2	Style Requirements.....	19
2.8	Operational and Environmental Requirements	19
2.9.1	Expected Physical Requirements	19
2.9.2	The Requirements for Interfacing Adjacent System.....	19
2.9	Legal Requirements.....	20
2.10	Compliance Requirements	20

CHAPTER 3.....	21
SYSTEM ANALYSIS.....	21
3.1 Use Case Diagram	21
3.1.1 Use Case Diagram for Owner	22
3.1.2 Use Case Diagram for Tenant.....	23
3.1.3 Use Case Diagram for Admin.....	24
3.1.4 Use Case diagram for Guest	25
3.2 Use Case Description.....	26
3.2.1 Registration	26
3.2.2 Login.....	27
3.2.3 Select User-role	28
3.2.4 Create Property Post	29
3.2.5 View Property Post.....	30
3.2.6 Update Property Post.....	31
3.2.7 Delete Property Post	32
3.2.8 Create Necessity Post	33
3.2.9 View Necessity Post	34
3.2.10 Update Necessity Post	35
3.2.11 Delete Necessity Post	36
3.2.12 Add Area Guide	37
3.2.13 View Area Guide.....	38
3.2.14 Update Area Guide	39
3.2.15 Delete Area Guide	40
3.2.16 Add Area Blog	41
3.2.17 View Area Blog.....	42
3.2.18 Update Area Blog.....	43
3.2.19 Delete Area Blog.....	44
3.2.20 FAQ	45
3.2.21 Logout.....	46
3.1 Activity Diagram.....	47
3.3.1 Registration	47
3.3.2 Login.....	47
3.3.3 Create Property Post	48
3.3.4 View Property Post.....	49

3.3.5	Update Property Post.....	50
3.3.6	Delete Property Post.....	51
3.3.7	Create Necessity Post.....	52
3.3.8	View Necessity Post.....	53
3.3.9	Update Necessity Post.....	54
3.3.10	Delete Necessity Post.....	55
3.3.11	Add Area Guide.....	56
3.3.12	View Area Guide.....	56
3.3.13	Edit Area Guide.....	57
3.3.14	Delete Area Guide.....	58
3.3.15	Add Area Blog.....	59
3.3.16	View Area Blog.....	59
3.3.17	Edit Area Blog.....	60
3.3.18	Delete Area Blog.....	61
3.3.19	Logout.....	61
3.3.20	FAQ.....	62
3.2	Sequence Diagram.....	63
3.4.1	Property Issue for Owner, Tenant and.....	63
3.4.2	Property Issue for Admin.....	64
3.4.3	Necessity Issue for Tenant, Owner and Guest.....	65
3.4.4	Necessity Issue for Admin.....	66
3.4.5	Area Guide Issue.....	67
3.4.6	Area Blog Issue.....	68
CHAPTER 4.....		69
SYSTEM DESIGN SPECIFICATION.....		69
4.1	Development Tools and Technology.....	69
4.1.1	User Interface Technology.....	69
4.1.2	Implementation Tools and Platform.....	69
4.1	Entity Relationship Diagram.....	70
4.2	Class Diagram.....	71
CHAPTER 5.....		72
SYSTEM TEST.....		72
5.1	Testing Features.....	72
5.1.1	Owner's features.....	72

5.1.2	Guest’s features	73
5.1.3	Admin features	74
5.1.4	Tenant features	75
5.2	Requirements Traceability Matrix.....	76
5.3	Black Box Testing with Test Cases.....	77
5.3.1	Registration	78
5.3.2	Login.....	79
5.3.3	Select User-role	80
5.3.4	Create Property Post	81
5.3.5	View Property Post.....	82
5.3.6	Update Property Post	83
5.3.7	Delete Property Post	84
5.3.8	Create Necessity Post	85
5.3.9	View Necessity Post	86
5.3.10	Update Necessity Post	87
5.3.11	Delete Necessity Post	88
5.3.12	Add Area Guide	89
5.3.13	View Area Guide.....	90
5.3.14	Update Area Guide	91
5.3.15	Delete Area Guide	92
5.3.16	Add Area Blog	93
5.3.17	View Area Blog.....	94
5.3.18	Edit Area Blog	95
5.3.19	Delete Area Blog.....	96
5.3.20	FAQ	97
5.3.21	Logout.....	98
CHAPTER 6.....		99
USER MANUAL		99
6.1	Home Page	99
6.2	Property for Guest.....	99
6.3	Necessity for Guest.....	100
6.4	Area Guide	100
6.5	About Us	101
6.6	Contact Us	101

6.7	Registration Page	102
6.8	Login Page.....	102
6.9	Forget Password.....	103
6.10	Admin Dashboard	103
6.11	Property view for Admin	104
6.12	Add Property for Admin	104
6.13	Update Property for Admin	105
6.14	Delete Property for Admin	105
6.15	Necessity view for Admin	106
6.16	Add Necessity for Admin	106
6.17	Update Necessity for Admin.....	107
6.18	Delete Necessity for Admin.....	107
6.19	Add Area Guide	108
6.20	View Area Guide for Admin.....	108
6.21	Delete Area guide.....	109
6.22	Manage About Us.....	109
6.23	Logout for Admin.....	110
6.24	Owner Dashboard.....	110
6.25	Create Property Post for Owner	111
6.26	View Property Post for Owner.....	111
6.27	Update Property Post for Owner	112
6.28	Delete Property Post for Owner	112
6.29	View Necessity Post for Owner	113
6.30	Logout for Owner.....	113
6.31	Tenant Dashboard	114
6.32	Create Necessity Post for Tenant	114
6.33	View Necessity Post for Tenant.....	115
6.34	Update Necessity Post for Tenant	115
6.35	Delete Necessity Post for Tenant	116
6.36	View Property Post for Tenant.....	116
6.37	Logout for Tenant.....	117
CHAPTER 7.....		118
CONCLUSION		118
7.1	GitHub Link	118

7.2	Project Summary	118
7.3	Limitation.....	118
7.4	Future Scope	118
	REFERENCES.....	119
	PLAGIARISM REPORT	120

Lists of Figures and Tables

Figure 1.1:	System Model for Digital To-Let System.....	5
Table 1.1:	Priority Chart	7
Table 1.2:	Priority of the system features based on Priority Chart	8
Figure 3.1:	Use case diagram for Digital To-Let System.....	21
Figure 3.2:	Use Case Diagram for Owner	22
Figure 3.3:	Use Case Diagram for Tenant	23
Figure 3.4:	Use Case Diagram for Admin	24
Figure 3.5:	Use Case Diagram for Guest.....	25
Figure 3.6:	Activity Diagram for Registration.....	47
Figure 3.7:	Activity Diagram for Login	47
Figure 3.8:	Activity Diagram for Create Property	48
Figure 3.9:	Activity Diagram for View Property Post.....	49
Figure 3.10:	Activity Diagram for Update Property Post.....	50
Figure 3.11:	Activity Diagram for Delete Property Post	51
Figure 3.12:	Activity Diagram for Create Necessity Post	52
Figure 3.13:	Activity Diagram for View Necessity Post	53
Figure 3.14:	Activity Diagram for Update Necessity Post	54
Figure 3.15:	Activity Diagram for Delete Necessity Post	55
Figure 3.16:	Activity Diagram for Add Area Guide	56
Figure 3.17:	Activity Diagram for View Area Guide.....	56
Figure 3.18:	Activity Diagram for Edit Area Guide.....	57
Figure 3.19:	Activity Diagram for Delete Area Guide	58
Figure 3.20:	Activity Diagram for Add Area Blog	59
Figure 3.21:	Activity Diagram for View Area Blog.....	59
Figure 3.22:	Activity Diagram for Edit Area Blog	60
Figure 3.23:	Activity Diagram for Delete Area Blog	61
Figure 3.24:	Activity Diagram for Logout.....	61
Figure 3.25:	Activity Diagram for FAQ.....	62
Figure 3.26:	Property Issue for Owner, Tenant and Guest	63
Figure 3.27:	Property Issue for Admin	64
Figure 3.28:	Necessity Issue for Tenant, Owner and Guest	65
Figure 3.29:	Necessity Issue for Admin	66
Figure 3.30:	Area Guide Issue	67
Figure 3.31:	Area Blog Issue	68
Figure 4.1:	Entity Relationship Diagram for Digital To-let System (DTS)	70
Figure 4.2:	Class diagram for Digital To-let System	71
Figure 6.1:	Home page	99

Figure 6.2: Property for Guest	99
Figure 6.3: Necessity for Guest.....	100
Figure 6.4: Area Guide	100
Figure 6.5: About Us	101
Figure 6.6: Contact Us.....	101
Figure 6.7: Registration Page.....	102
Figure 6.8: Login Page	102
Figure 6.9: Forget Password	103
Figure 6.10: Admin Dashboard.....	103
Figure 6.11: Property view for Admin	104
Figure 6.12: Add Property for Admin	104
Figure 6.13: Update Property for Admin.....	105
Figure 6.14: Delete Property for Admin.....	105
Figure 6.15: Necessity view for Admin.....	106
Figure 6.16: Add Necessity for Admin.....	106
Figure 6.17: Update Necessity for Admin	107
Figure 6.18: Delete Necessity for Admin	107
Figure 6.19: Add Area Guide.....	108
Figure 6.20: View Area Guide for Admin	108
Figure 6.21: Delete Area guide	109
Figure 6.22: Manage About Us.....	109
Figure 6.23: Logout for Admin	110
Figure 6.24: Owner Dashboard	110
Figure 6.25: Create Property Post for Owner	111
Figure 6.26: View Property Post for Owner	111
Figure 6.27: Update Property Post for Owner	112
Figure 6.28: Delete Property Post for Owner	112
Figure 6.29: View Necessity Post for Owner	113
Figure 6.30: Logout for Owner	113
Figure 6.31: Tenant Dashboard.....	114
Figure 6.32: Create Necessity Post for Tenant.....	114
Figure 6.33: View Necessity Post for Tenant	115
Figure 6.34: Update Necessity Post for Tenant	115
Figure 6.35: Delete Necessity Post for Tenant.....	116
Figure 6.36: View Property Post for Tenant.....	116
Figure 6.37: Logout for Tenant	117

CHAPTER 1

INTRODUCTION

1.1 Project Overview

Bangladesh is the most densely populated country in the world. Bangladesh ranks 11th in terms of population density. That's why its population faces an accommodation problem.

Bangladesh is improving the Educational sector day by day. Even the Rural students have realized the value of education. They are moving to the city for the sake of satisfying their hunger for education. As all the students don't belong to a well-established family, so they want to complete their education with limited expenses.

In our country, all industrial factories are situated in urban areas. That's why everyone from the lower class people to the upper-middle class is moving to the city. That's why there is a crisis for housing every year.

Most of the people are rushing from villages to cities for better treatment as all the well-facilitated hospitals are located in urban areas. Many have no relatives in the town. They face more problems in this case.

If we consider the situation a few months ago, we see that Bangladesh, like other countries, is in the grip of an epidemic. As a result, many have lost their jobs and have been forced to return to their respective villages. The homeowners have also suffered for this. But it will not be easy to find a home by maintaining safety when everything is back to normal and everyone is back at work.

By using Digital To-let System, people can easily search for home and able to alleviate the difficulty of finding their home.

1.2 Project Purpose

The “**Digital To-Let System**” is a web-based project that will help the general people for the sake of searching rented home/seat/sublet. As our country is a densely populated country that’s why every moment there is a crisis of accommodation. My system will help a tenant to find his/her desired home or seat or sublet which is given by the Owner. If he/she wants to contact the Owner, he/she can easily get the information through the system. On the other hand the system will not only solve the tenants’ problem but also able to solve the owners’ problem by getting information from tenant.

1.2.1 Background

Previously I have mentioned that Bangladesh is the most densely populated country and there is a lack of accommodation. I will not deny that there is no other source for rent. Of course there is, but I mean to say there is not a proper source. The owner still puts up posters to rent out their house, which seems unreasonable to me. Because now a days, everything is under the internet. So, I think Digital To-let system is a platform that can remove the all hassles and will be a proper website for the general people.

1.2.2 Benefits and Beneficiaries

My proposed project is **Digital To-let System** that will help the general people for searching rented home. Since my project will not only solve one specific problem, it is also effective in solving many problems at the same time so I think my field of work involves a lot of people at the same time.

My system will help a tenant to find his/her desired home or seat which is given by the owner directly. If he/she wants to contact with the owner, he/she can easily get the information through the system.

My system will help a tenant to find his/her desired home or seat which is given by the owner directly. If he/she wants to contact with the owner, he/she can easily get the information through the system.

There is an option for the tenant that he/she can search temporarily to stay with package requirements. Because most of the people are rushing from villages to cities for better treatment as all the well hospitals are located in urban areas. Many have no relatives in the town. They face more problems in this case. For solving this problem the option will helpful for them.

My system will provide information to the users according to their searching location.

If anyone wants to maintain his/her budget, he/she can also search home/seat according to his/her budget. That's mean it can also solve the budget issue.

Sometimes the owner or general-user has some issues that's why can't hang any to-let for their home/seat. For solving their problem they can create a post and easily can find a tenant.

1.2.3 Goals

My goal is to help the general people to fulfill their one basic need which is Accommodation needs. My project will not only solve the accommodation problem but also take care of the budget of the people as well as be able to stay in the location of their choice. So, I just want to help them through my project.

1.3 Stakeholders

In my project, I have defined four stakeholders. They are Admin, Owner, Tenant & Guest. Admin, Owner & Tenant are my internal stakeholders and Guest is my external stakeholder.

1.3.1 Owner

An owner is the owner of property (such as land, houses, apartments and hostels) that is leased or rented or another. In my system, the Owner can create a post for tenant, can view/delete/edit post if it is created. He can also view the tenant necessity post which is given by tenant.

1.3.2 Tenant

A tenant has the occupation or temporary possession of lands or tenements of another. In my system the tenant can search his/her desired home according to his/her choice (location or budget). The system will also help the tenant to create a post for his/her need which can be seen by the owner.

1.3.3 Guest

In my system, the guest users can only have the access to view some selected information. Guest users don't have the access to search home. But the guest user can ask any question to the system admin providing with his/her email.

1.3.4 Admin

The whole system will be supervised by Admin. He has the access to the all posts which is submitted by tenants and owner. He has the authority do delete posts. In a word, Admin is all in all in the system.

1.4 System model for Digital To-Let System

For developing my project I have proposed a system model. This will clarify the system in a brief.

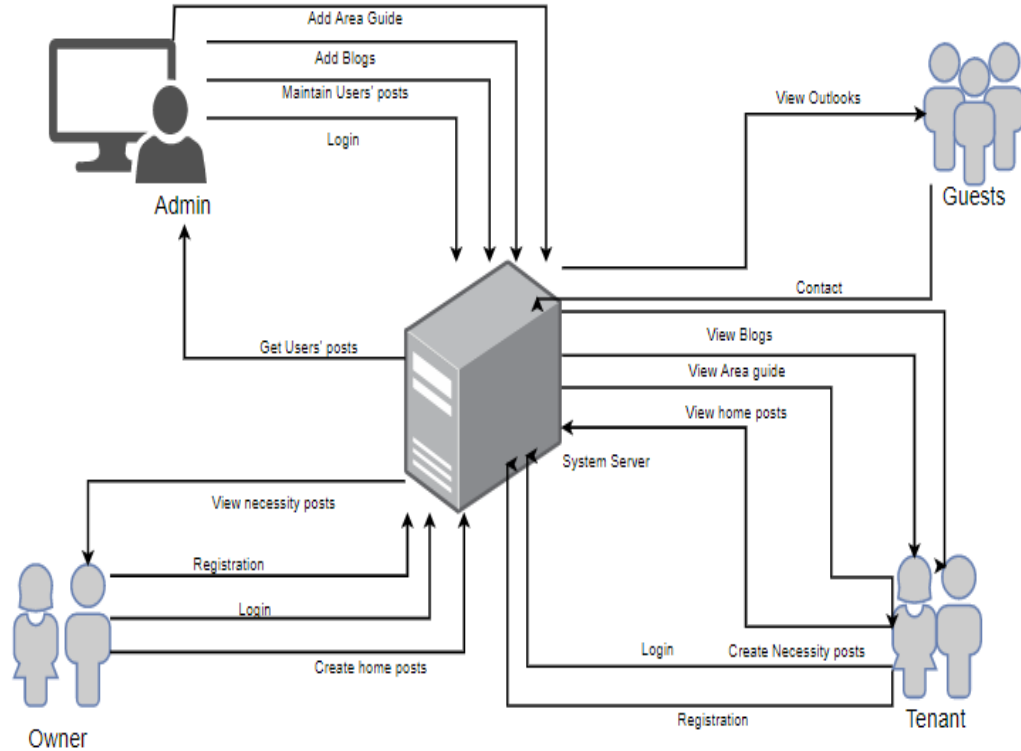

Figure 1.1: System Model for Digital To-Let System

In this system, there are four different users can interact with the system. Admin can maintain the users' posts and also have access on Area guide and Area blog. Owner only has the full access on his/her own property post and only can see the necessity posts created by tenant. Tenant has the full access on his/her on necessity post and can see the property post created by owner. Tenant can also view the Area guide and Area blog. The guest has only the access on some features like contact, about system etc.

CHAPTER 2

SOFTWARE REQUIREMENT SPECIFICATION (SRS)

We all know that, a project must be developed by considering with requirements. Without requirements, no one can build a single project. In this portion we are going to discuss the requirements related to my project.

2.1 Functional Requirements

There is no system without functional requirements. Therefore, I have tried to find out the functional requirements and arrange them considering to their priority in my project.

Priority Chart

It is a technique to assemble the requirements according to priority. Using this technique, we can easily categorized the functional requirements that can be performed by my system and can identify which function should get High Priority and which one should get Medium Priority and which one get Low Priority.

There are two parts of a Priority Matrix such as Important and Urgent.

If any function is:

Important also Urgent =High Priority

Important but not Urgent =Medium Priority

Not Important but Urgent =Low Priority

Not Important and not Urgent =Ignore

Important/Urgent	Yes	No
Yes	High Priority	Medium Priority
No	Low Priority	Ignore

Table 1.1: Priority Chart

FR ID	Description	Important	Urgent	Priority
FR01	Registration for users	Yes	Yes	High
FR02	Login for authenticate users	Yes	Yes	High
FR03	Logout for authenticate users	Yes	Yes	High
FR04	Can create property post	Yes	Yes	High
FR05	Can view property posts	Yes	Yes	High
FR06	Can update property posts	Yes	Yes	High
FR07	Can delete property posts	Yes	Yes	High
FR08	Can view necessity posts	Yes	Yes	High
FR09	Property search by location	Yes	No	High
FR10	Property search by amount	Yes	No	High
FR11	Can create necessity posts	Yes	Yes	High
FR12	Can update necessity posts	Yes	Yes	High
FR13	Can delete necessity posts	Yes	Yes	High
FR14	Can view Area Guide	Yes	Yes	High
FR15	Can view Blog	Yes	Yes	High
FR16	Can add Area Guide	Yes	Yes	High
FR17	Can edit Area Guide	Yes	Yes	High

FR 18	Can delete Area Guide	Yes	Yes	High
FR19	Can add Blog	Yes	Yes	High
FR20	Can edit Blog	Yes	Yes	High
FR21	Can delete Blog	Yes	Yes	High
FR22	Contact with system admin	Yes	Yes	High
FR23	Retrieve password by email	Yes	No	Medium

Table 1.2: Priority of the system features based on Priority Chart

2.1.1 Registration for users

FR01	Registration for users			
Description	Users can create a new account by providing required information through the registration form. The user needs to submit a request post by clicking “Register” button from the Home page.			
Stakeholders	Owner, Tenant, Admin	Priority	High	

2.1.2 Login for authenticate users

FR02	Login for authenticate users			
Description	Authenticate users can login to the system by using email and password.			
Stakeholders	Owner, Tenant, Admin	Priority	High	

2.1.3 Logout for authenticate users

FR03	Logout for authenticate users		
Description	Authenticate users can logout from the system by clicking “logout” button.		
Stakeholders	Owner, Tenant, Admin	Priority	High

2.1.4 Can create property post

FR04	Can create property post		
Description	Can create a new property post by providing required information. The user needs to submit a request post by clicking “Submit” button.		
Stakeholders	Owner	Priority	High

2.1.5 Can view property posts

FR05	Can view property posts		
Description	Can view property posts by clicking required button.		
Stakeholders	Owner, Admin, Tenant, Guest	Priority	High

2.1.6 Can update property posts

FR06	Can update property posts		
Description	Can update property posts by clicking “update” button.		
Stakeholders	Owner, Admin	Priority	High

2.1.7 Can delete property posts

FR07	Can delete property posts		
Description	Can delete property posts if it seems unnecessary by clicking “delete” button.		
Stakeholders	Owner, Admin	Priority	High

2.1.8 Can view necessity posts

FR08	Can view necessity posts		
Description	Can view necessity posts by clicking required button		
Stakeholders	Tenant, Owner, Admin, Guest	Priority	High

2.1.9 Property search by location

FR09	Property search by location		
Description	Can search property details by selecting location.		
Stakeholders	Tenant, Admin, Owner	Priority	High

2.1.10 Property search by amount

FR10	Property search by amount		
Description	Can search property details by selecting amount/budget.		
Stakeholders	Tenant, Admin, Owner	Priority	High

2.1.11 Can create necessity posts

FR11	Can create necessity posts		
Description	Can create a new necessity post by providing some required information. The user needs to submit a request post by clicking “Submit” button.		
Stakeholders	Tenant	Priority	High

2.1.12 Can update necessity posts

FR12	Can update necessity posts		
Description	Can update necessity information by clicking “update” button.		
Stakeholders	Tenant, Admin	Priority	High

2.1.13 Can delete necessity posts

FR13	Can delete necessity posts		
Description	Can delete necessity posts if it seems unnecessary by clicking “delete” button.		
Stakeholders	Tenant, Admin	Priority	High

2.1.14 Can view Area Guide

FR14	Can view Area Guide		
Description	Can view Area Guide by clicking “Area Guide” option.		
Stakeholders	Tenant, Admin, Owner, Guest	Priority	High

2.1.15 Can view Blog

FR15	Can view Blog		
Description	Can view Blog by clicking “Blog” option.		
Stakeholders	Tenant, Admin, Owner, Guest	Priority	High

2.1.16 Can add Area Guide

FR16	Can add Area Guide		
Description	Can add YouTube link as Area Guide by providing location. The user needs to submit a request post by clicking “Submit” button.		
Stakeholders	Admin	Priority	High

2.1.17 Can edit Area Guide

FR17	Can edit Area Guide		
Description	Can edit Area Guide information by clicking “Edit” button		
Stakeholders	Admin	Priority	High

2.1.18 Can delete Area Guide

FR18	Can delete Area Guide		
Description	Can delete Area Guide if it seems unnecessary.		
Stakeholders	Admin	Priority	High

2.1.19 Can add Blog

FR19	Can add Blog		
Description	Can add blog by providing location. The user needs to submit a request post by clicking “Submit” button.		
Stakeholders	Admin	Priority	High

2.1.20 Can edit Blog

FR20	Can edit Blog		
Description	Can edit Blog information by clicking “Edit” button		
Stakeholders	Admin	Priority	High

2.1.21 Can delete Blog

FR21	Can delete Blog		
Description	Can delete Blogs if it seems unnecessary.		
Stakeholders	Admin	Priority	High

2.1.22 Contact with system admin

FR22	Contact with system admin		
Description	Can contact with system by providing email.		
Stakeholders	Owner, Tenant, Guest	Priority	High

2.1.23 Retrieve password by email

FR23	Retrieve password by email		
Description	If users forget their password, they can retrieve password by email by clicking “Forgot Password?” option.		
Stakeholders	Owner, Tenant	Priority	Medium

2.2 Performance Requirements

Performance requirements defines how well the system performs under the required condition. It can be justified by measuring speed of response, throughput, execution time and storage capacity etc.

2.2.1 Speed and latency Requirements

In some cases, the legal requirements will dictate the response time. User satisfaction is largely dependent on response time in a system. If the system takes more than 10 seconds to load, it will be possibility to avoid the system by the users.

PR01	View and post result should be displayed in less than 1 second		
Description	When the user wants to see any information and want to manage the posts, the result must be shown in less than 3 second time period.		
Stakeholders	Owner, Tenant, Guest, Admin	Priority	High

2.2.2 Accuracy Requirements

Always should show the accurate result for all users. It is not accepted to show any wrong information.

PR02	Information should be accurate		
Description	When the user wants to see any information then the system must ensure that the provided information is most accurate.		
Stakeholders	Owner, Tenant, Guest, Admin	Priority	High

2.2.3 Capacity Requirements

The system should be capable of supporting a certain number of users and a certain number of interactions. It should not get crushed easily.

PR03	Information should be accurate		
Description	When the user wants to see any information then the system must ensure that the provided information is most accurate.		
Stakeholders	Owner, Tenant, Guest, Admin	Priority	High

2.3 Dependability Requirements

Dependability is a measure of a system's services to the users. It is based on five criteria. They are

- Reliability
- Availability
- Maintainability
- Durability
- Safety and Security

In my system, I have used three of them to fulfill the Dependability Requirements.

2.3.1 Reliability Requirements

DR01	System must provide continuity for correct service		
Description	All the information providing by the system must be reliable.		
Stakeholders	Owner, Tenant, Guest, Admin	Priority	High

2.3.2 Availability Requirements

DR02	The availability of the system to deliver services when requested.		
Description	The system must be available 24/7. It must be able to deliver services to the user when requested.		
Stakeholders	Owner, Tenant, Guest, Admin	Priority	High

2.3.3 Maintainability Requirements

DR03	Ability for easy maintenance		
Description	The system should provide the maintenance issue to the user.		
Stakeholders	Admin	Priority	High

2.4 Security System Requirements

System security is one of the most important requirements for any project. For the lacking of security service, the data could be manipulated. The system can face cyber-attack.

SR01: Login as Owner

SR02: Login as Tenant

SR03: Login as Admin

SR04: Logout as Owner

SR05: Logout as Tenant

SR06: Logout as Admin

2.5 Usability and Human-Interaction Requirements

User experience is one of the most important factors to any system. When anyone or any company develops any system, they try to make the system easier. That's why the system must be easy to use, easy to understand and easy to learn.

2.5.1 Ease of Use Requirements

The system is very easy to use and easy to understand. There is no long process to complete a task. User can complete any task with only a few steps.

EUR01	The system must be usable for all type of users		
Description	The system should be usable for the Owner, Admin and Tenant. The Guest user can also able to use the system.		
Stakeholders	Admin, Owner, Tenant, Guest	Priority	High

2.5.2 Understand Ability and Politeness Requirements

The system can be used by all types of people. The system will not use any term that is not specified in this web application.

2.5.3 Accessibility Requirements

The system is very user friendly. It is easy to use and understand for the users. There is no access requirements besides those that has been outline in the below:

AR ID	AR Name
AR01	Login as Admin
AR02	Login as Owner
AR03	Login as Tenant
AR04	Logout as Admin
AR05	Logout as Owner
AR06	Logout as Tenant

2.5.4 User Documentation Requirements

User feedback will be taken and analyzed properly to understand and fulfil their expectations. The requirements will be added to the system after proper analyzation.

2.6 Training Requirements

A simple user manual will be provided to the user for training purposes. The system is really easy to understand so extensive training is not required.

2.7 Look and Feel Requirements

User will feel bored to look at a monotonous user interface. Look and feel requirements provide information on how the system will look like and how the user interface or graphical user interface of the system will display to the user.

2.7.1 Appearance Requirements

LFR01	Mandatory input fields must have visible marking		
Description	If there is any mandatory input field in any form, the field must have visible marking for the user.		
Stakeholders	Owner, Tenant, Admin	Priority	High

2.7.2 Style Requirements

LFR02	All content must appear within the same format		
Description	Input field and other view results must be shown in a specific format.		
Stakeholders	Owner, Tenant, Admin, Guest	Priority	Medium

2.8 Operational and Environmental Requirements

This requirement focuses on how the users operate the system, include in interfaces and interoperability with other systems. The requirement established how the system can perform under conditions.

2.9.1 Expected Physical Requirements

There is no specific expected physical requirements.

2.9.2 The Requirements for Interfacing Adjacent System

There is no specific interface with adjacent system requirements.

2.9 Legal Requirements

Legal requirements are the rules and regulations set by any organization.

2.10 Compliance Requirements

There is no specific compliance requirements.

CHAPTER 3

SYSTEM ANALYSIS

3.1 Use Case Diagram

A use case diagram is a representation of a user's interaction with the system that shows the relationship between the user and the different use cases in which the user is involved. In My system, except Admin, all the users are primary actor. Owner can create property posts and Tenant can see those posts. On the other hand, Tenant can create necessity posts and Owner can view the post. Admin can do anything as he/she wants. He/she has the access to all the posts created by any users. Guest users has some specific field.

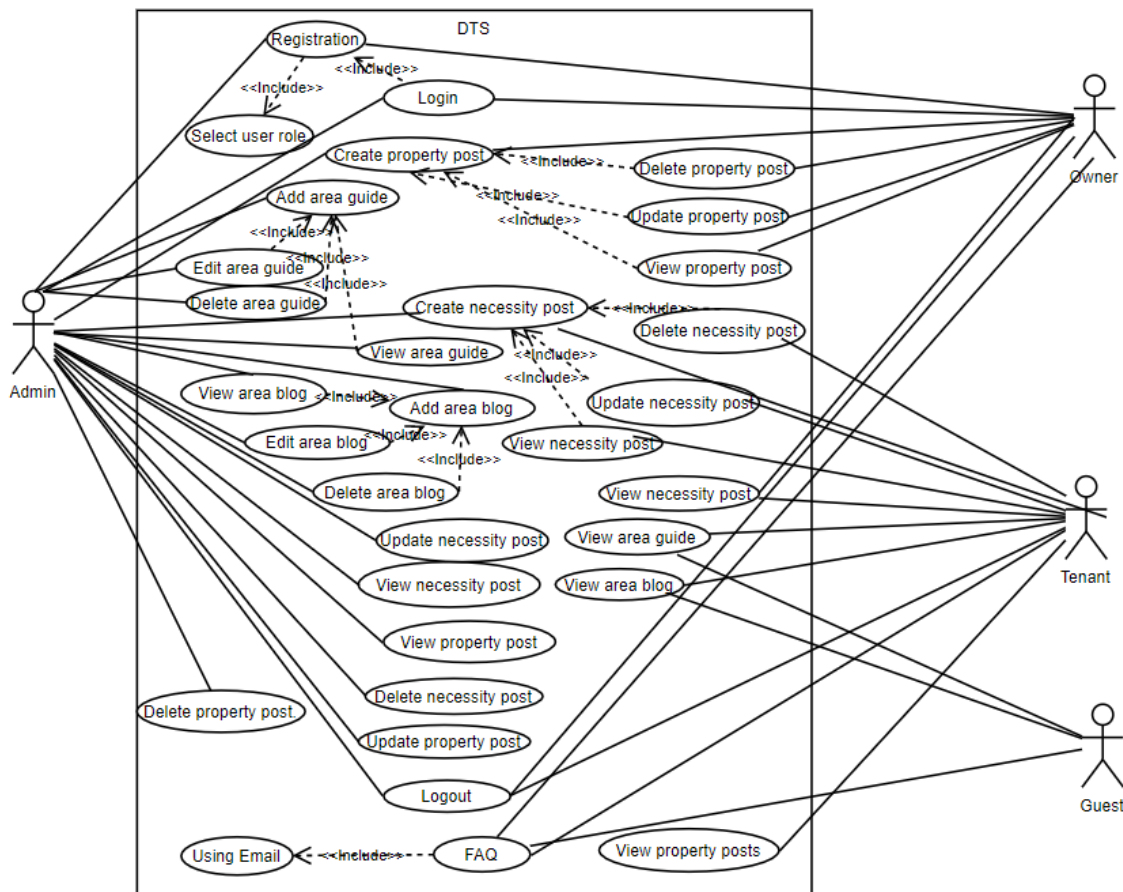

Figure 3.1: Use case diagram for Digital To-Let System

3.1.1 Use Case Diagram for Owner

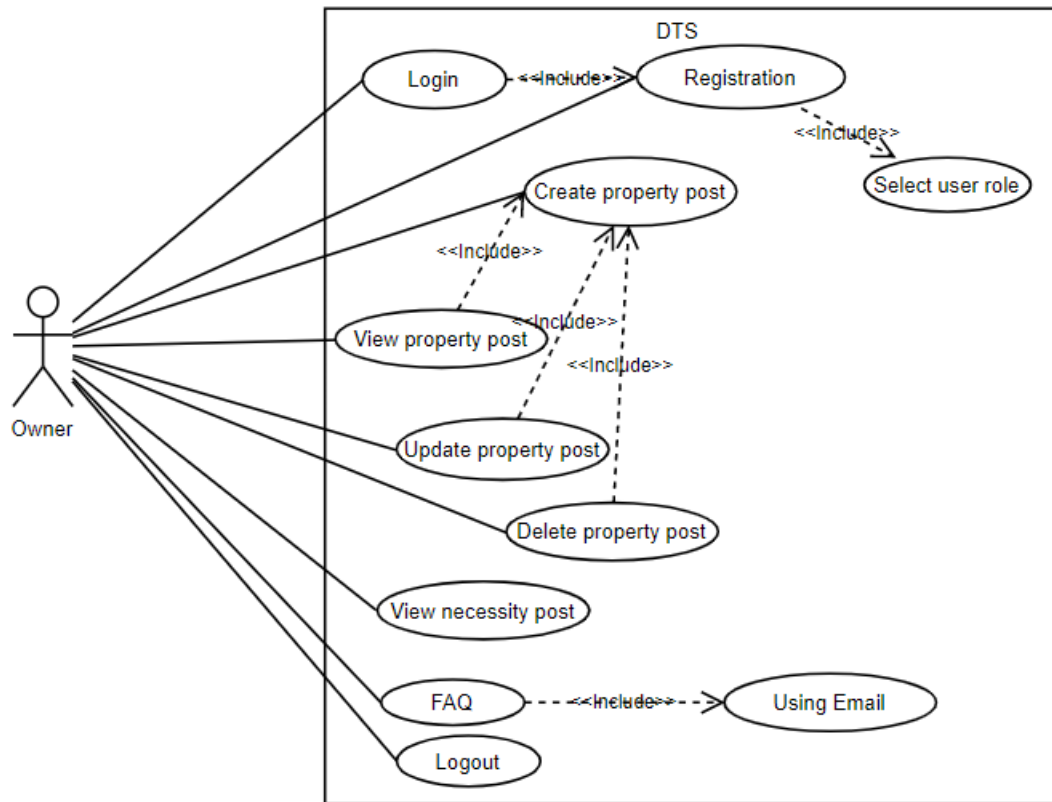

Figure 3.2: Use Case Diagram for Owner

Figure 3.2 represents the Owner Use Case Diagram. In my system, Owner needs to do registration for login to the system. After logging into the system, owner can create the property posts for the sake of rent. He has also the access to make any changes in his/her created posts. Our system will also provide to the owner about Necessity posts created by tenant.

3.1.2 Use Case Diagram for Tenant

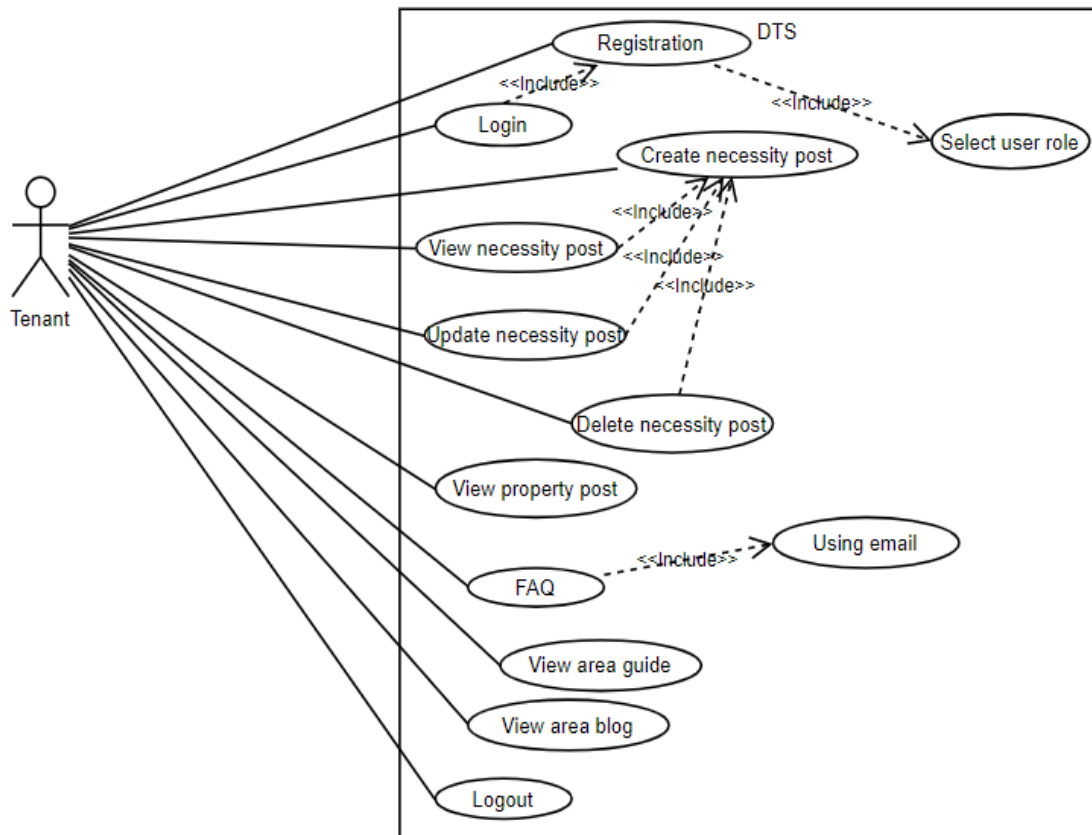

Figure 3.3: Use Case Diagram for Tenant

Figure 3.3 represents the Tenant Use Case Diagram. In my system, Tenant needs to do registration for login to the system. After logging into the system, Tenant can create the necessity posts for the sake of rent. He has also the access to make any changes in his/her created posts. Our system will also provide to the tenant about Property posts created by owner. Tenant can also see the area guide and area blog.

3.1.3 Use Case Diagram for Admin

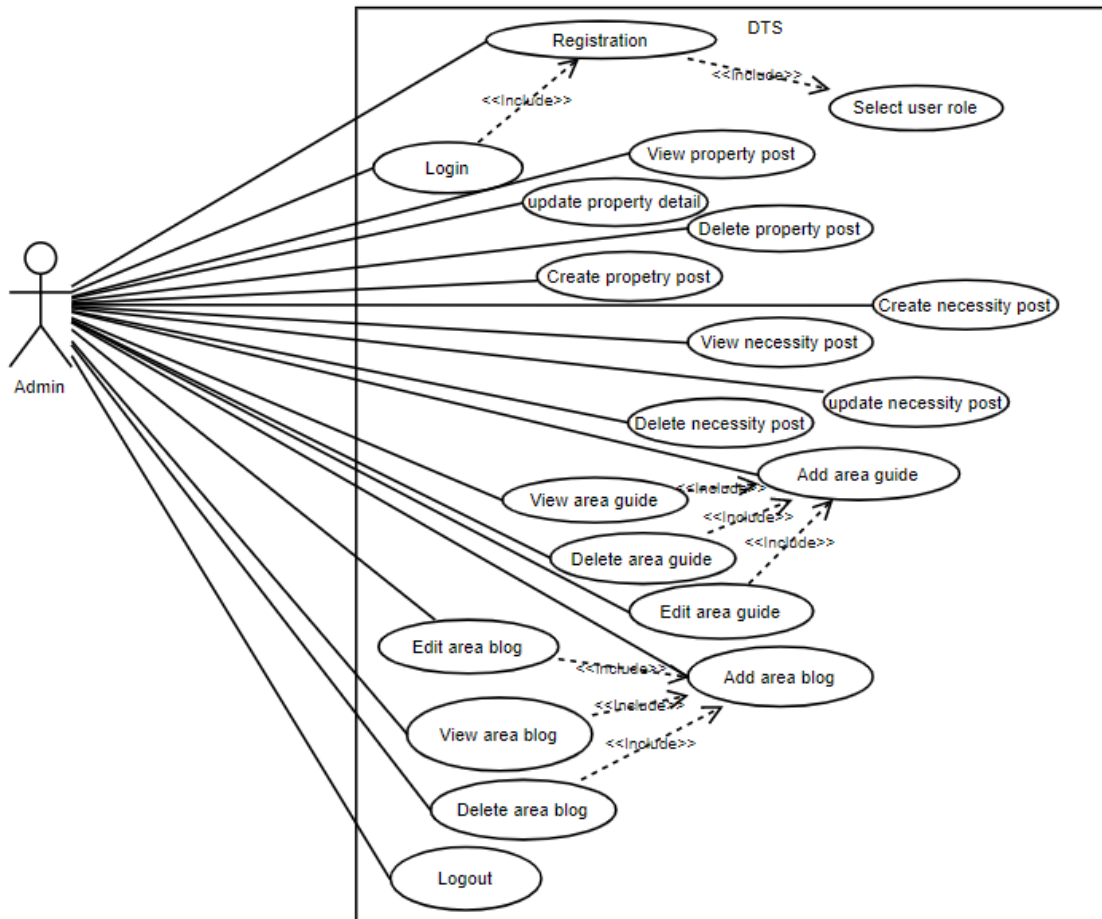

Figure 3.4: Use Case Diagram for Admin

Figure 3.4 represents the Admin Use Case Diagram. As we all know, an Admin is all in all in a system. Therefore, the whole system will be controlled by the Admin. He can make any changes to any user's posts. He can create the area blog and area guide and only he can make any changes to these portion. He can also send the answer which is come to the Guest users.

3.1.4 Use Case diagram for Guest

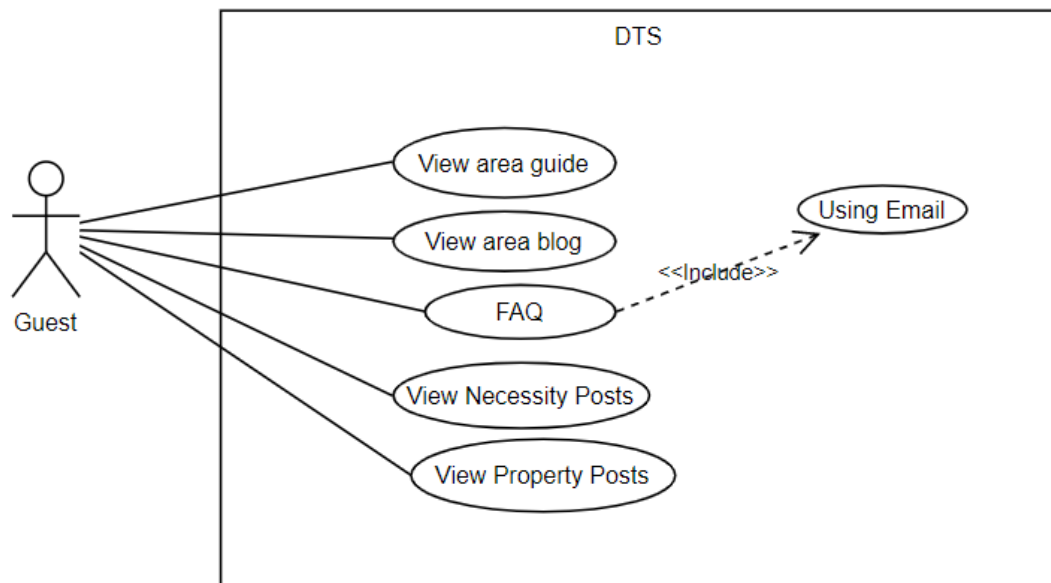

Figure 3.5: Use Case Diagram for Guest

Figure 3.5 represents the Guest Use Case Diagram. My system will give specific access to the Guest users. They can only view area guide and area blog and can send FAQ to the system Admin providing their email.

3.2 Use Case Description

3.2.1 Registration

Use Case	New account registration for Users	
Goal	Users can create an account successfully	
Precondition	N/A	
Success End Condition	New account is created	
Failed End Condition	Already have an account with the given email address	
Primary Actor	Owner, Tenant, Admin	
Secondary Actor	N/A	
Trigger	Click on the “Register” button	
Description / Main Success Scenario	Step	Action
	1	System will displays the Registration page
	2	Users fill-up the required fields
	3	Users clicks on the “Register” button
	4	Users has registered an account successfully
Alternative Flows	Step	Branching Action
	1	Mandatory / required input fields are not filled in
	2	Cannot access the system
Quality Requirements	Step	Requirements
	1	N/A

3.2.2 Login

Use Case	Login for registered users	
Goal	Registered users can login successfully	
Precondition	Registration successfully	
Success End Condition	Access to users' Dashboard	
Failed End Condition	Failed to login	
Primary Actor	Owner, Tenant, Admin	
Secondary Actor	N/A	
Trigger	Click on the "Login" button	
Description / Main Success Scenario	Step	Action
	1	System will displays the Login page
	2	It is mandatory to fill-up the login page with correct information
	3	Users clicks on the "Login" button
	4	Users has logged in successfully
Alternative Flows	Step	Branching Action
	1	Mandatory / required input fields are not filled with correct information
	2	Cannot access the system
Quality Requirements	Step	Requirements
	1	N/A

3.2.3 Select User-role

Use Case	Select User-role for Users	
Goal	Users can select role successfully	
Precondition	N/A	
Success End Condition	Users identity is created successfully	
Failed End Condition	Already selected the same role with same email.	
Primary Actor	Owner, Tenant, Admin	
Secondary Actor	N/A	
Trigger	Click on the “User-role” button	
Description / Main Success Scenario	Step	Action
	1	System will displays the Registration page
	2	Users fill-up the required fields with selecting user-role module
	3	Users select the user-role option
	4	Users has gained his/her required role successfully
Alternative Flows	Step	Branching Action
	1	User-role doesn't select
	2	Cannot access the system
Quality Requirements	Step	Requirements
	1	N/A

3.2.4 Create Property Post

Use Case	Create Property Post	
Goal	Users can create a property post successfully	
Precondition	Should be registered user	
Success End Condition	Create property post properly	
Failed End Condition	Failed to create property post	
Primary Actor	Owner	
Secondary Actor	Admin	
Trigger	Click on the “Submit” button	
Description / Main Success Scenario	Step	Action
	1	System will displays the “Property create” page
	2	Users fill-up the required fields
	3	Users clicks on the “Submit” button
	4	Users has created a property post successfully
Alternative Flows	Step	Branching Action
	1	Mandatory / required input fields are not filled in
	2	Cannot create property post
Quality Requirements	Step	Requirements
	1	N/A

3.2.5 View Property Post

Use Case	View Property Post	
Goal	Users can View Property Post successfully	
Precondition	Should be registered user	
	Property Post must be created by Owner	
Success End Condition	View Property Post Successfully	
Failed End Condition	Failed to see the Property Post	
Primary Actor	Owner, Tenant	
Secondary Actor	Admin	
Trigger	Click on the “View Property” button	
Description / Main Success Scenario	Step	Action
	1	System will displays the Dashboard page
	2	Users clicks on the “View Property” button
	3	Users can see the Property Post successfully
Alternative Flows	Step	Branching Action
	1	The system is failed to show Property Post
Quality Requirements	Step	Requirements
	1	N/A

3.2.6 Update Property Post

Use Case	Update Property post	
Goal	Users can update property information successfully	
Precondition	Should be Registered User	
	Property Post must be created by Owner	
Success End Condition	Update property post information successfully	
Failed End Condition	Failed to update information	
Primary Actor	Owner	
Secondary Actor	Admin	
Trigger	Click on the “Update” button	
Description / Main Success Scenario	Step	Action
	1	System will displays the Property Post
	2	Users can change information if he/she wants
	3	Users clicks on the “Update” button
	4	Users can update some information successfully
Alternative Flows	Step	Branching Action
	1	Data mismatched
	2	Failed to update
Quality Requirements	Step	Requirements
	1	N/A

3.2.7 Delete Property Post

Use Case	Delete Property Post	
Goal	Users can delete a post successfully if it seems unnecessary	
Precondition	Should be registered users	
	Property post must be created by owner	
Success End Condition	Successfully deleting post	
Failed End Condition	Failed to delete	
Primary Actor	Owner	
Secondary Actor	Admin	
Trigger	Click on the “Delete” button	
Description / Main Success Scenario	Step	Action
	1	System will displays the Property Post page
	2	Users clicks on the “Delete” button
	4	Users has deleted a property post successfully
Alternative Flows	Step	Branching Action
	1	Cannot delete a property post successfully
Quality Requirements	Step	Requirements
	1	N/A

3.2.8 Create Necessity Post

Use Case	Create Necessity Post	
Goal	Users can create a necessity post successfully	
Precondition	Should be registered user	
Success End Condition	Create necessity post properly	
Failed End Condition	Failed to create necessity post	
Primary Actor	Tenant	
Secondary Actor	Admin	
Trigger	Click on the “Submit” button	
Description / Main Success Scenario	Step	Action
	1	System will displays the “Necessity create” page
	2	Users fill-up the required fields
	3	Users clicks on the “Submit” button
	4	Users has created a necessity post successfully
Alternative Flows	Step	Branching Action
	1	Mandatory / required input fields are not filled in
	2	Cannot create necessity post
Quality Requirements	Step	Requirements
	1	N/A

3.2.9 View Necessity Post

Use Case	View Necessity Post	
Goal	Users can View Necessity Post successfully	
Precondition	Should be registered user	
	Necessity Post must be created by Tenant	
Success End Condition	View Necessity Post Successfully	
Failed End Condition	Failed to see the Necessity Post	
Primary Actor	Owner, Tenant	
Secondary Actor	Admin	
Trigger	Click on the “View Necessity” button	
Description / Main Success Scenario	Step	Action
	1	System will displays the Dashboard page
	2	Users clicks on the “View Necessity” button
	3	Users can see the Necessity Post successfully
Alternative Flows	Step	Branching Action
	1	The system is failed to show Necessity Post
Quality Requirements	Step	Requirements
	1	N/A

3.2.10 Update Necessity Post

Use Case	Update Necessity post	
Goal	Users can update necessity information successfully	
Precondition	Should be Registered User	
	Necessity Post must be created by Tenant	
Success End Condition	Update necessity post information successfully	
Failed End Condition	Failed to update information	
Primary Actor	Tenant	
Secondary Actor	Admin	
Trigger	Click on the “Update” button	
Description / Main Success Scenario	Step	Action
	1	System will displays the Necessity Post
	2	Users can change information if he/she wants
	3	Users clicks on the “Update” button
	4	Users can update some information successfully
Alternative Flows	Step	Branching Action
	1	Data mismatched
	2	Failed to update
Quality Requirements	Step	Requirements
	1	N/A

3.2.11 Delete Necessity Post

Use Case	Delete Necessity Post	
Goal	Users can delete a post successfully if it seems unnecessary	
Precondition	Should be registered users	
	Necessity post must be created by owner	
Success End Condition	Successfully deleting post	
Failed End Condition	Failed to delete	
Primary Actor	Tenant	
Secondary Actor	Admin	
Trigger	Click on the “Delete” button	
Description / Main Success Scenario	Step	Action
	1	System will displays the Necessity Post page
	2	Users clicks on the “Delete” button
	4	Users has deleted a necessity post successfully
Alternative Flows	Step	Branching Action
	1	Cannot delete a necessity post successfully
Quality Requirements	Step	Requirements
	1	N/A

3.2.12 Add Area Guide

Use Case	Add Area Guide	
Goal	Users can create an Area Guide successfully	
Precondition	Should be registered user	
Success End Condition	Add Area Guide properly	
Failed End Condition	Failed to create Area Guide	
Primary Actor	Admin	
Secondary Actor	N/A	
Trigger	Click on the “Submit” button	
Description / Main Success Scenario	Step	Action
	1	System will displays the “Add Area” page
	2	Users fill-up the required fields
	3	Users clicks on the “Submit” button
	4	Users has created an Area Guide successfully
Alternative Flows	Step	Branching Action
	1	Mandatory / required input fields are not filled in
	2	Cannot add Area Guide
Quality Requirements	Step	Requirements
	1	N/A

3.2.13 View Area Guide

Use Case	View Area Guide	
Goal	Users can View Area Guide successfully	
Precondition	Area Guide must be created by Admin	
Success End Condition	View Area Guide Successfully	
Failed End Condition	Failed to see the Area Guide	
Primary Actor	Owner, Tenant, Admin, Guest	
Secondary Actor	N/A	
Trigger	Click on the “View Area Guide” button	
Description / Main Success Scenario	Step	Action
	1	System will displays the Home page
	2	Users clicks on the “View Area Guide” button
	3	Users can see the Area Guide successfully
Alternative Flows	Step	Branching Action
	1	The system is failed to show Area Guide
Quality Requirements	Step	Requirements
	1	N/A

3.2.14 Update Area Guide

Use Case	Update Area Guide	
Goal	Users can update area guide information successfully	
Precondition	Should be Registered User	
	Area Guide must be created by Admin	
Success End Condition	Update Area guide information successfully	
Failed End Condition	Failed to update information	
Primary Actor	Admin	
Secondary Actor	N/A	
Trigger	Click on the “Update” button	
Description / Main Success Scenario	Step	Action
	1	System will displays the Area Guide
	2	Users can change information if he/she wants
	3	Users clicks on the “Update” button
	4	Users can update some information successfully
Alternative Flows	Step	Branching Action
	1	Data mismatched
	2	Failed to update
Quality Requirements	Step	Requirements
	1	N/A

3.2.15 Delete Area Guide

Use Case	Delete Area Guide	
Goal	Users can delete Area Guide successfully if it seems unnecessary	
Precondition	Should be registered users	
	Area Guide must be created by Admin	
Success End Condition	Successfully deleting post	
Failed End Condition	Failed to delete	
Primary Actor	Admin	
Secondary Actor	N/A	
Trigger	Click on the “Delete” button	
Description / Main Success Scenario	Step	Action
	1	System will displays the Area Guide page
	2	Users clicks on the “Delete” button
	4	Users has deleted area guide successfully
Alternative Flows	Step	Branching Action
	1	Cannot delete area guide successfully
Quality Requirements	Step	Requirements
	1	N/A

3.2.16 Add Area Blog

Use Case	Add Area Blog	
Goal	Users can create an Area Blog successfully	
Precondition	Should be registered user	
Success End Condition	Add Area Blog properly	
Failed End Condition	Failed to create Area Blog	
Primary Actor	Admin	
Secondary Actor	N/A	
Trigger	Click on the “Submit” button	
Description / Main Success Scenario	Step	Action
	1	System will displays the “Add Blog” page
	2	Users fill-up the required fields
	3	Users clicks on the “Submit” button
	4	Users has created an Area Blog successfully
Alternative Flows	Step	Branching Action
	1	Mandatory / required input fields are not filled in
	2	Cannot add Area Blog
Quality Requirements	Step	Requirements
	1	N/A

3.2.17 View Area Blog

Use Case	View Area Blog	
Goal	Users can View Area Blog successfully	
Precondition	Area Blog must be created by Admin	
Success End Condition	View Area Blog Successfully	
Failed End Condition	Failed to see the Area Blog	
Primary Actor	Owner, Tenant, Admin, Guest	
Secondary Actor	N/A	
Trigger	Click on the “View Area Blog” button	
Description / Main Success Scenario	Step	Action
	1	System will displays the Home page
	2	Users clicks on the “View Area Blog” button
	3	Users can see the Area Blog successfully
Alternative Flows	Step	Branching Action
	1	The system is failed to show Area Blog
Quality Requirements	Step	Requirements
	1	N/A

3.2.18 Update Area Blog

Use Case	Update Area Blog	
Goal	Users can update area blog information successfully	
Precondition	Should be Registered User	
	Area Blog must be created by Admin	
Success End Condition	Update Area Blog information successfully	
Failed End Condition	Failed to update information	
Primary Actor	Admin	
Secondary Actor	N/A	
Trigger	Click on the “Update” button	
Description / Main Success Scenario	Step	Action
	1	System will displays the Area Blog
	2	Users can change information if he/she wants
	3	Users clicks on the “Update” button
	4	Users can update some information successfully
Alternative Flows	Step	Branching Action
	1	Data mismatched
	2	Failed to update
Quality Requirements	Step	Requirements
	1	N/A

3.2.19 Delete Area Blog

Use Case	Delete Area Blog	
Goal	Users can delete Area Blog successfully if it seems unnecessary	
Precondition	Should be registered users	
	Area Blog must be created by Admin	
Success End Condition	Successfully deleting post	
Failed End Condition	Failed to delete	
Primary Actor	Admin	
Secondary Actor	N/A	
Trigger	Click on the “Delete” button	
Description / Main Success Scenario	Step	Action
	1	System will displays the Area Blog page
	2	Users clicks on the “Delete” button
	4	Users has deleted area blog successfully
Alternative Flows	Step	Branching Action
	1	Cannot delete area blog successfully
Quality Requirements	Step	Requirements
	1	N/A

3.2.20 FAQ

Use Case	FAQ for the users	
Goal	Users can Ask any question to the Admin	
Precondition	N/A	
Success End Condition	Can Ask a question to the admin through email	
Failed End Condition	Failed to ask questions	
Primary Actor	Owner, Tenant, Guest	
Secondary Actor	N/A	
Trigger	Click on the “FAQ” button	
Description / Main Success Scenario	Step	Action
	1	System will displays the FAQ page
	2	Users can fill-up the required fields and ask any question
	3	Users clicks on the “submit” button
	4	Users question can be seen by Admin
Alternative Flows	Step	Branching Action
	1	Mandatory / required input fields are not filled in
	2	Cannot ask any question
Quality Requirements	Step	Requirements
	1	N/A

3.2.21 Logout

Use Case	Logout for registered users	
Goal	Users can log out of their account	
Precondition	Users must be logged in to the system	
Success End Condition	Users log out form their Dashboard	
Failed End Condition	Cannot access to the system	
Primary Actor	Owner, Tenant, Admin	
Secondary Actor	N/A	
Trigger	Click on the “Log out” button	
Description / Main Success Scenario	Step	Action
	1	System will displays the member dashboard
	2	Users clicks on the “Log Out” button
	4	Users get logged out to the system
Alternative Flows	Step	Branching Action
	1	Cannot access the system
Quality Requirements	Step	Requirements
	1	N/A

3.1 Activity Diagram

3.3.1 Registration

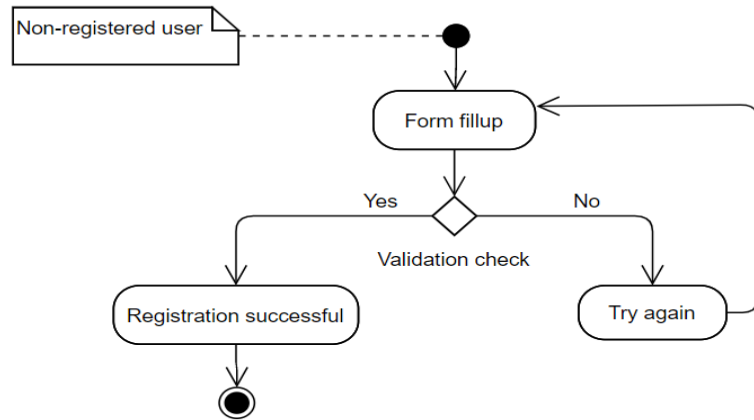

Figure 3.6: Activity Diagram for Registration

Figure 3.6 defines the Activity Diagram for Registration. Only non-registered users can do this activity. The system will provide a form for registration issue. Then, the system will check the validation of data and make the process complete.

3.3.2 Login

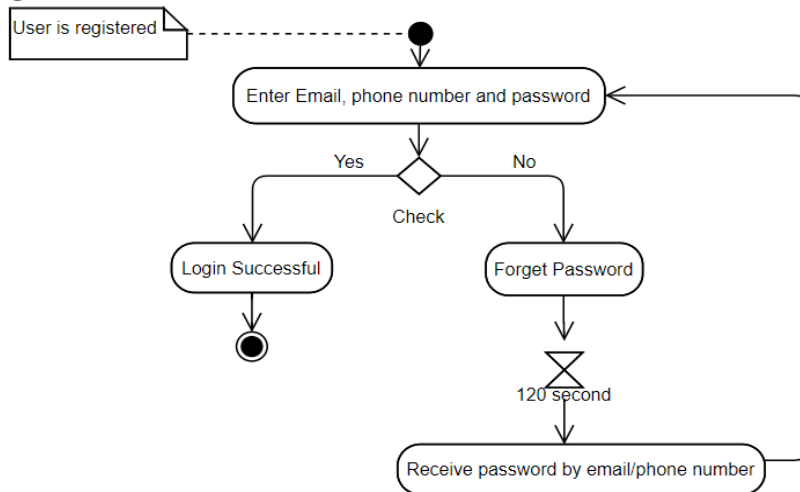

Figure 3.7: Activity Diagram for Login

Figure 3.7 defines the Activity Diagram for Login. Only registered users can do this activity. The system will want the email/ phone number and password to the users and check for authentication to complete the process.

3.3.3 Create Property Post

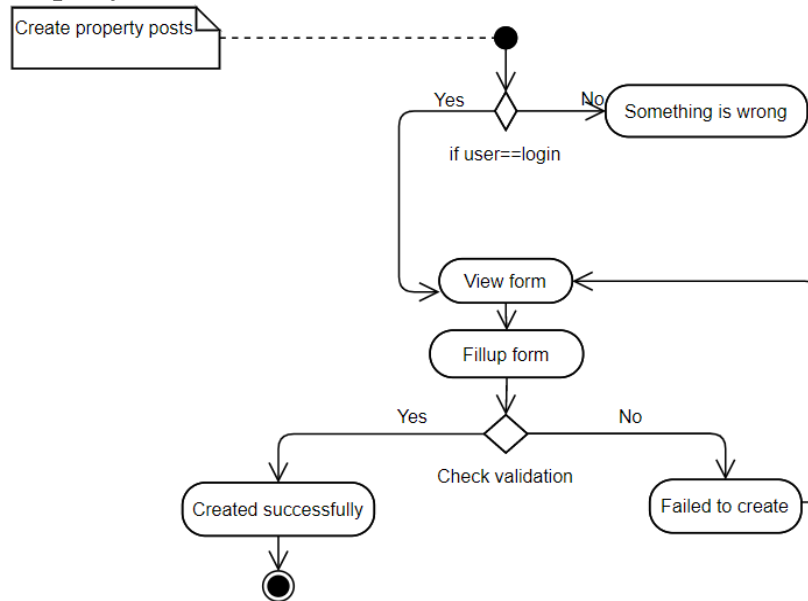

Figure 3.8: Activity Diagram for Create Property

Figure 3.8 represents the Activity Diagram for Create Property Post. Only the registered owner and admin users can have this access. They can create a property post by providing information about their property. Then the system will check the data validation and the process will be completed if the checking result is 'yes'. However, if the data validation result is 'no' then the process will give some message for data validation and the process will be started from the beginning.

3.3.4 View Property Post

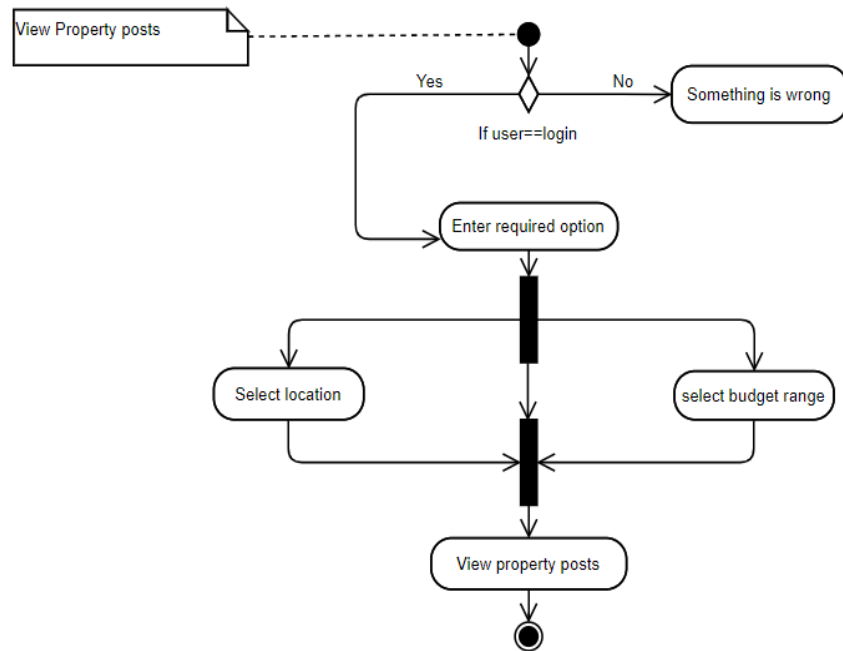

Figure 3.9: Activity Diagram for View Property Post

Figure 3.9 represents the Activity Diagram for View Property Post. All the users can access to the field and view the property posts which is created by Owner.

3.3.5 Update Property Post

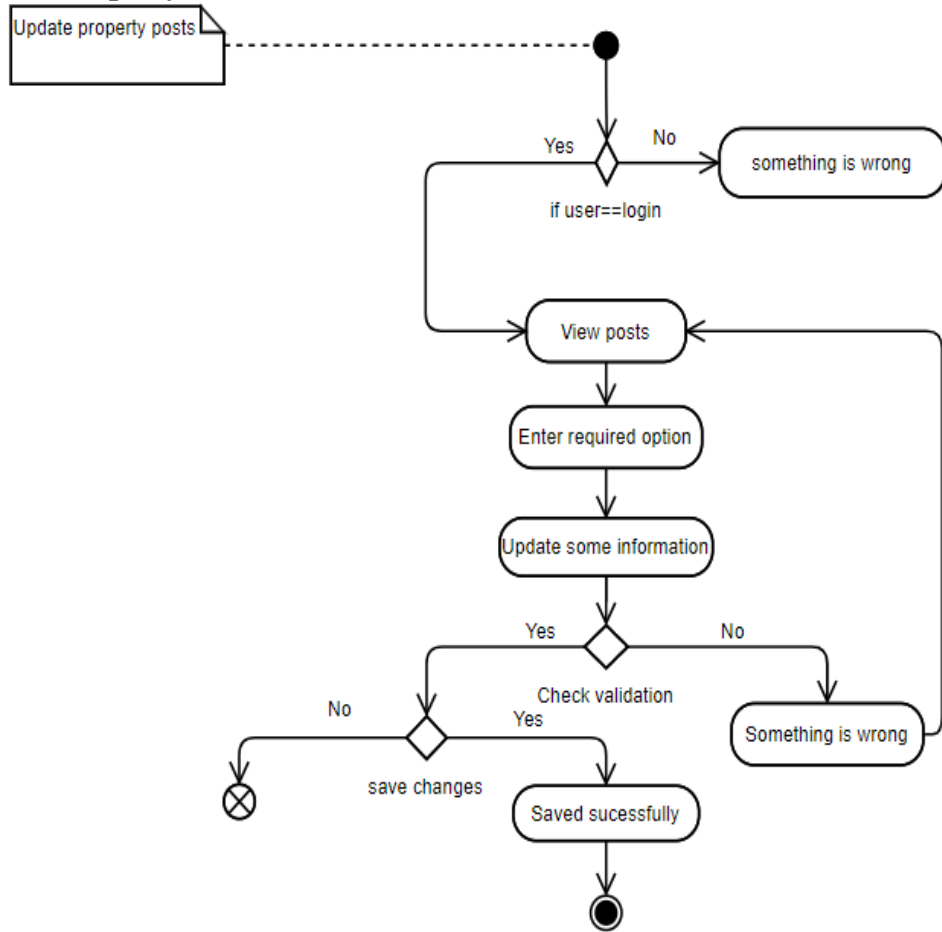

Figure 3.10: Activity Diagram for Update Property Post

Figure 3.10 represents the Activity Diagram for Update Property Post. The Owner and Admin can only do this activity if there is any created post. They can view the property post and specifically update any field by validating data.

3.3.6 Delete Property Post

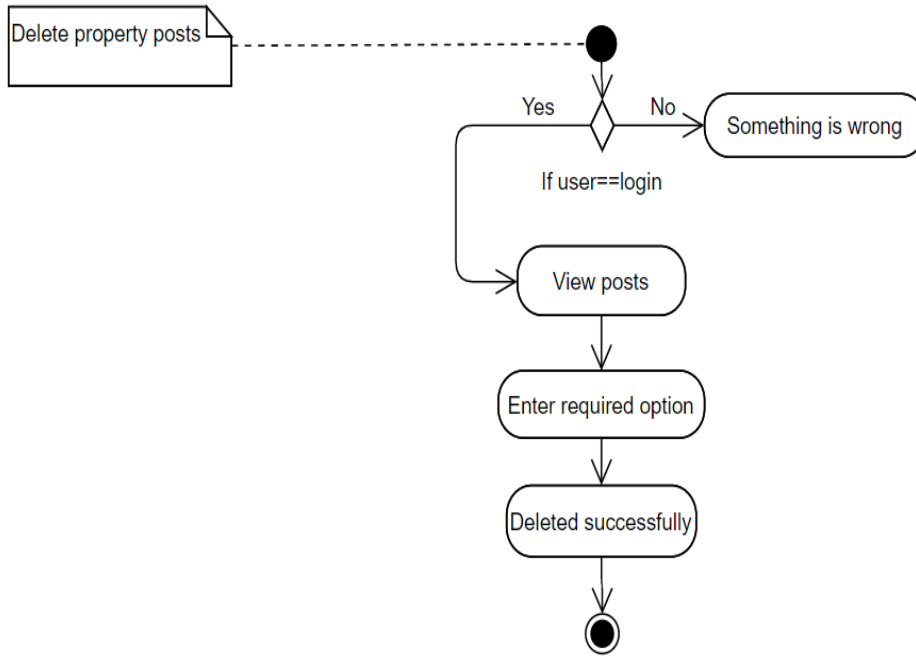

Figure 3.11: Activity Diagram for Delete Property Post

Figure 3.11 represents the Activity Diagram for Delete Property Post. The Owner and Admin can only do this activity if there is any created post. They can view the property post and specifically delete the post.

3.3.7 Create Necessity Post

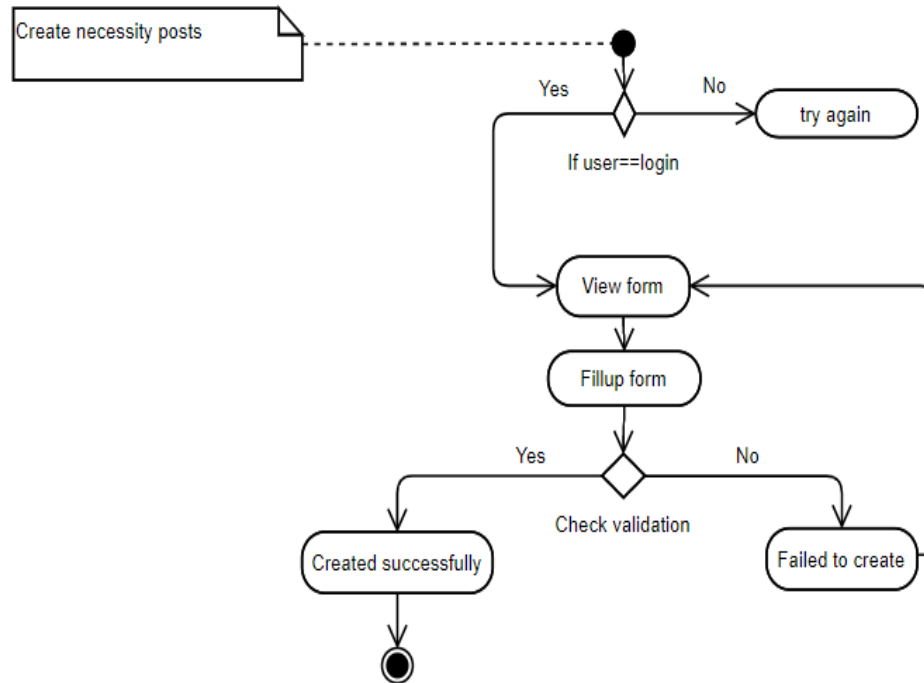

Figure 3 12: Activity Diagram for Create Necessity Post

Figure 3.12 represents the Activity Diagram for Create Necessity Post. Only the registered tenant and admin users can have this access. They can create a necessity post by providing information about their needs. Then the system will check the data validation and the process will be completed if the checking result is 'yes'. However, if the data validation result is 'no' then the process will give some message for data validation and the process will be started from the beginning.

3.3.8 View Necessity Post

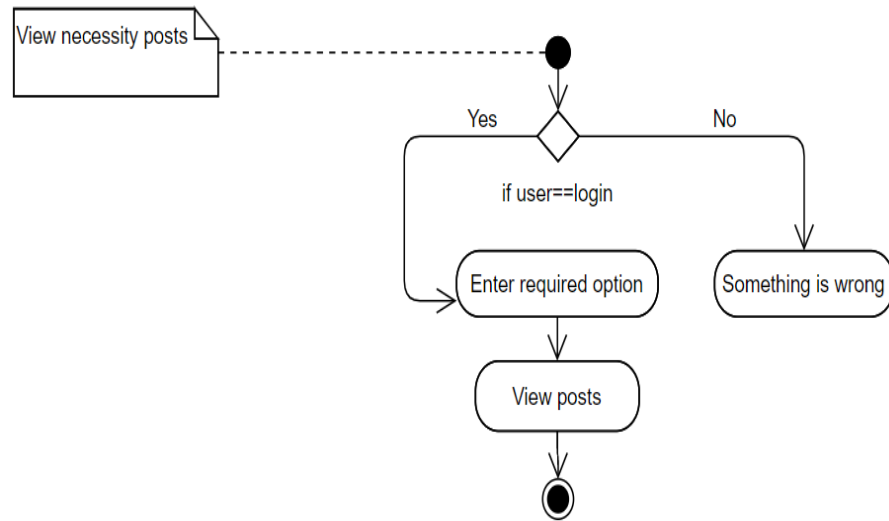

Figure 3 13: Activity Diagram for View Necessity Post

Figure 3.13 represents the Activity Diagram for View Necessity Post. All the users can access to the field and view the necessity posts which is created by Tenant.

3.3.9 Update Necessity Post

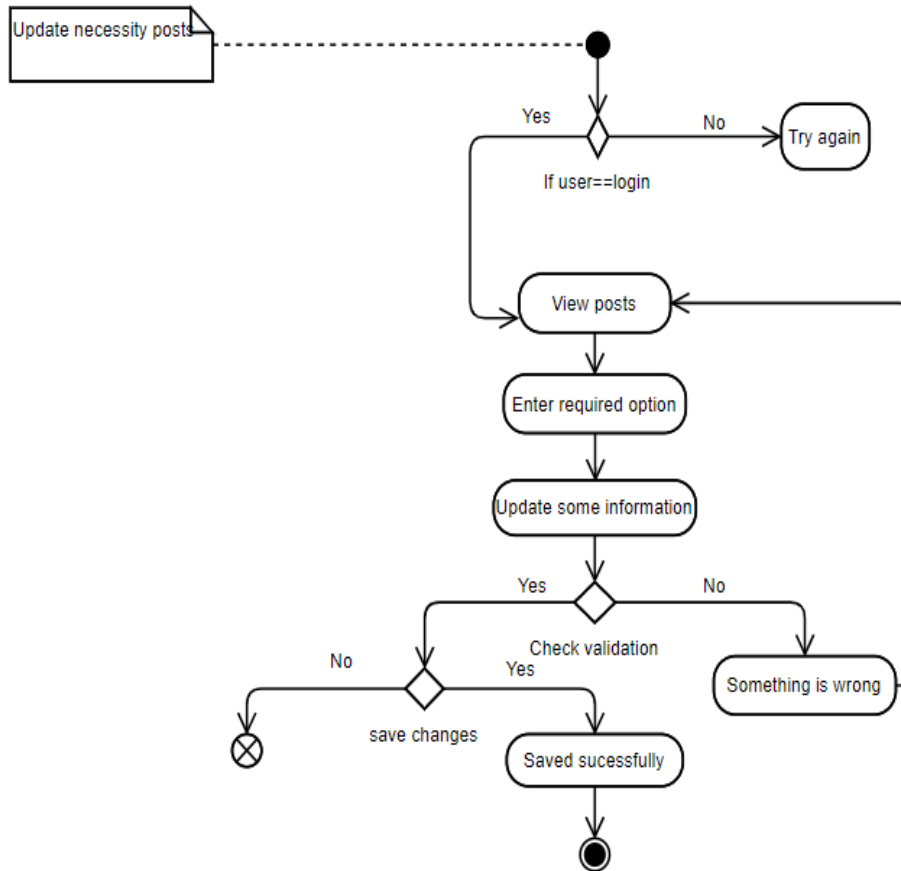

Figure 3 14: Activity Diagram for Update Necessity Post

Figure 3.14 represents the Activity Diagram for Update Property Post. The Tenant and Admin can only do this activity if there is any created post. They can view the property post and specifically update any field by validating data.

3.3.10 Delete Necessity Post

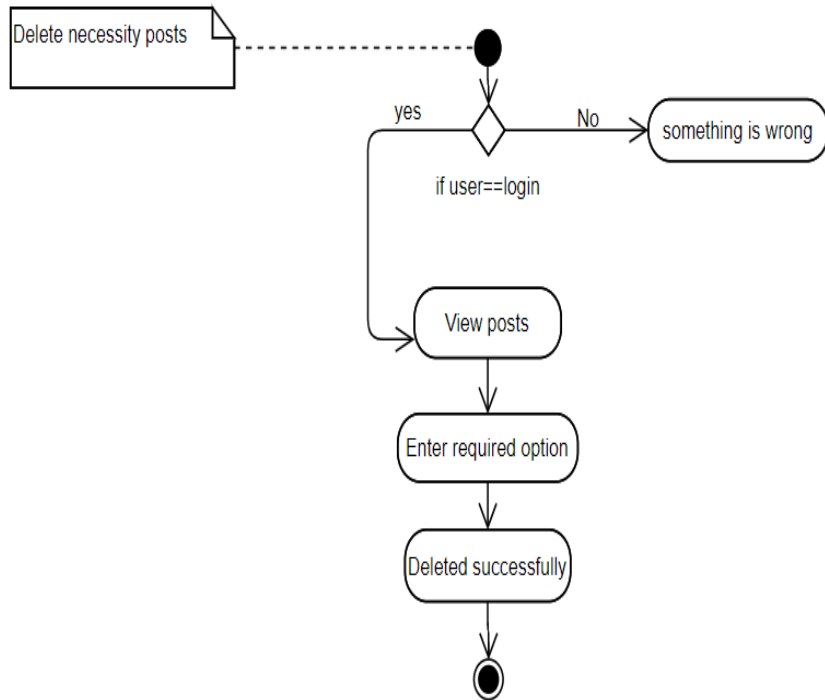

Figure 3.15: Activity Diagram for Delete Necessity Post

Figure 3.15 represents the Activity Diagram for Delete Necessity Post. The Tenant and Admin can only do this activity if there is any created post. They can view the property post and specifically delete the post.

3.3.11 Add Area Guide

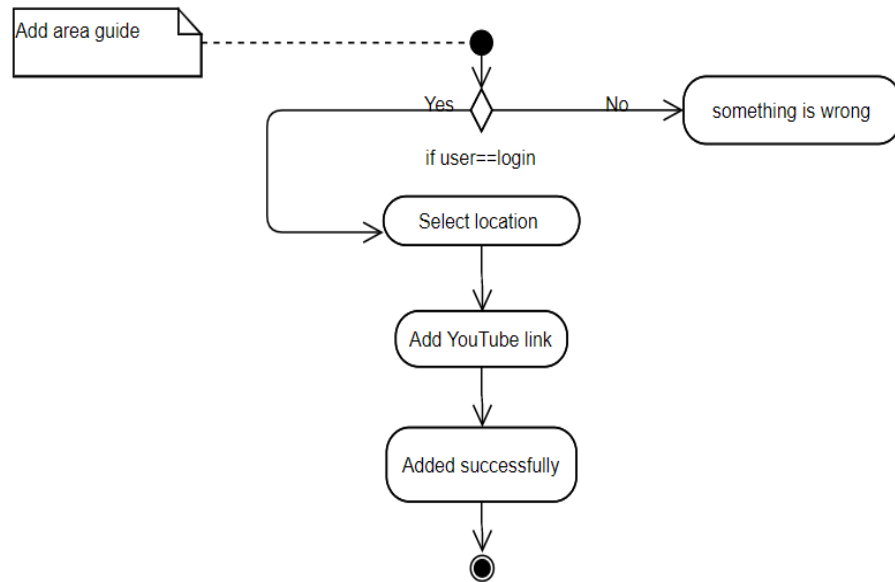

Figure 3.16: Activity Diagram for Add Area Guide

Figure 3.16 represents the Activity Diagram for Add Area Guide. Only the Admin can have this access. He/she can add an area guide by providing information. Then the system will check the data validation and the process will be completed if the checking result is 'yes'. However, if the data validation result is 'no' then the process will give some message for data validation and the process will be started from the beginning. It should be mentioned that, area guide must carry a YouTube link.

3.3.12 View Area Guide

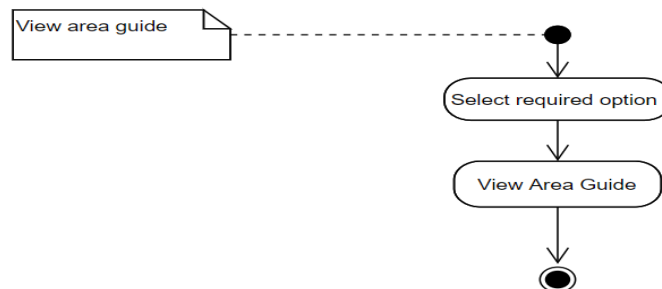

Figure 3.17: Activity Diagram for View Area Guide

Figure 3.17 represents the Activity Diagram for View Area Guide. All the users can access to the field and view the Area Guide.

3.3.13 Edit Area Guide

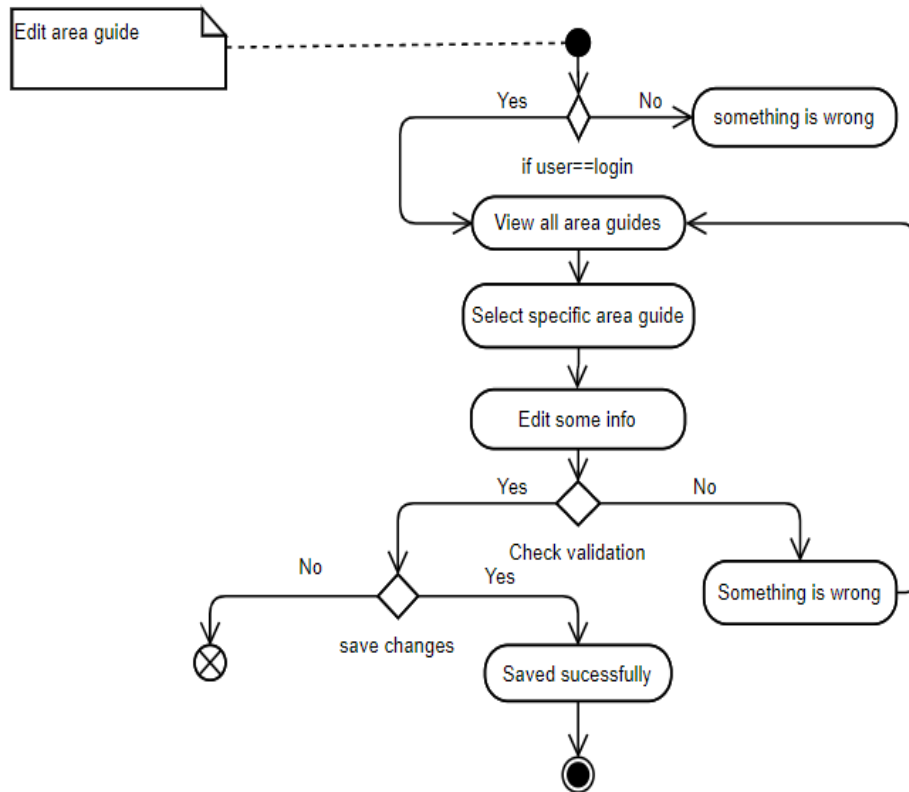

Figure 3.18: Activity Diagram for Edit Area Guide

Figure 3.18 represents the Activity Diagram for Edit Area Guide. The Admin can only do this activity if there is any created post. Admin can view the Area Guide and specifically update any field by validating data.

3.3.14 Delete Area Guide

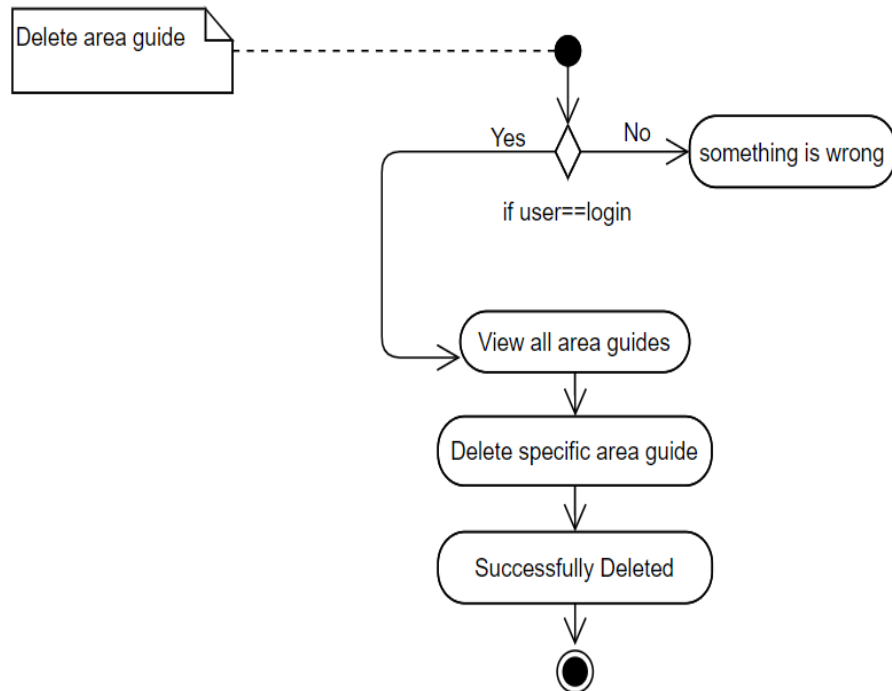

Figure 3.19: Activity Diagram for Delete Area Guide

Figure 3.19 represents the Activity Diagram for Delete Area Guide. Admin can only do this activity if there is any created post. Admin can view the area guide and specifically delete the post.

3.3.15 Add Area Blog

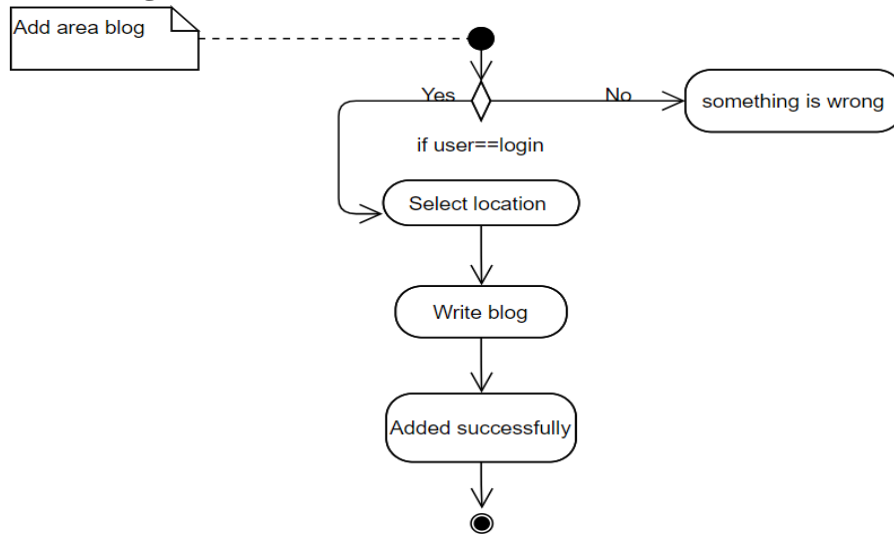

Figure 3.20: Activity Diagram for Add Area Blog

Figure 3.20 represents the Activity Diagram for Add Area Blog. Only the Admin can have this access. He/she can add an area blog by providing information. Then the system will check the data validation and the process will be completed if the checking result is 'yes'. However, if the data validation result is 'no' then the process will give some message for data validation and the process will be started from the beginning.

3.3.16 View Area Blog

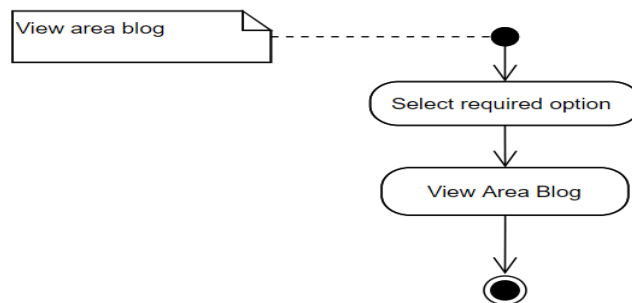

Figure 3.21: Activity Diagram for View Area Blog

Figure 3.21 represents the Activity Diagram for View Area Blog. All the users can access to the field and view the Area Blog.

3.3.17 Edit Area Blog

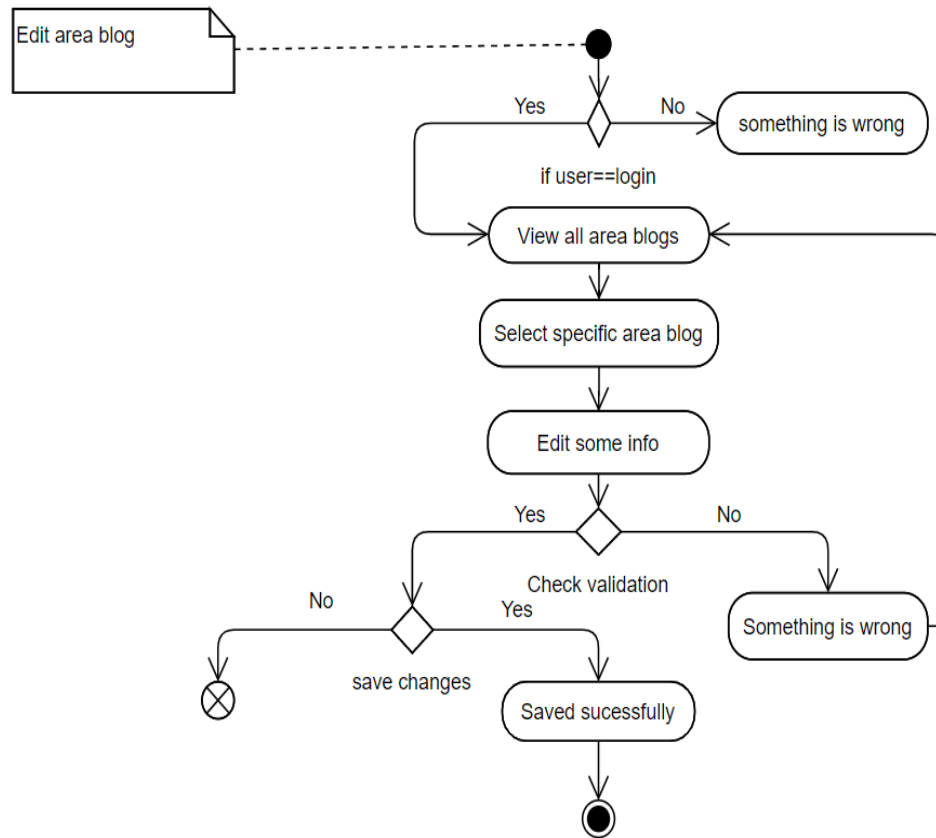

Figure 3.22: Activity Diagram for Edit Area Blog

Figure 3.22 represents the Activity Diagram for Edit Area Blog. The Admin can only do this activity if there is any created post. Admin can view the area blog and specifically update any field by validating data.

3.3.18 Delete Area Blog

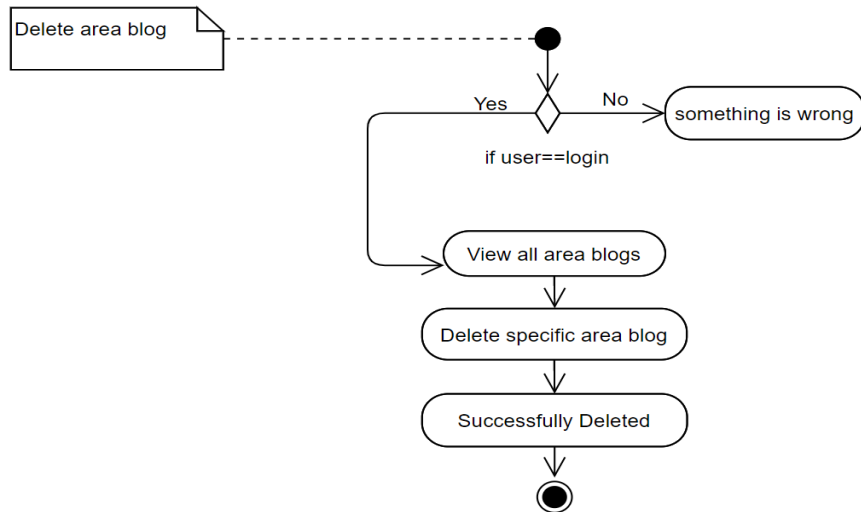

Figure 3.23: Activity Diagram for Delete Area Blog

Figure 3.23 represents the Activity Diagram for Delete Area Guide. Admin can only do this activity if there is any created post. Admin can view the area guide and specifically delete the post.

3.3.19 Logout

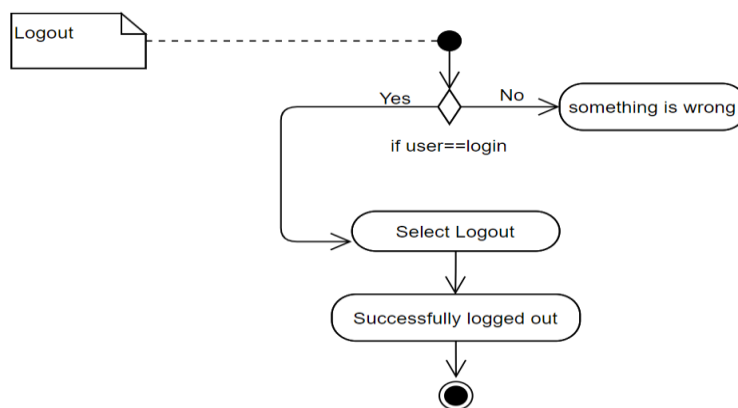

Figure 3.24: Activity Diagram for Logout

Figure 3.24 represents the Logout Activity. The registered users have the access and the users must be logged in to the system.

3.3.20 FAQ

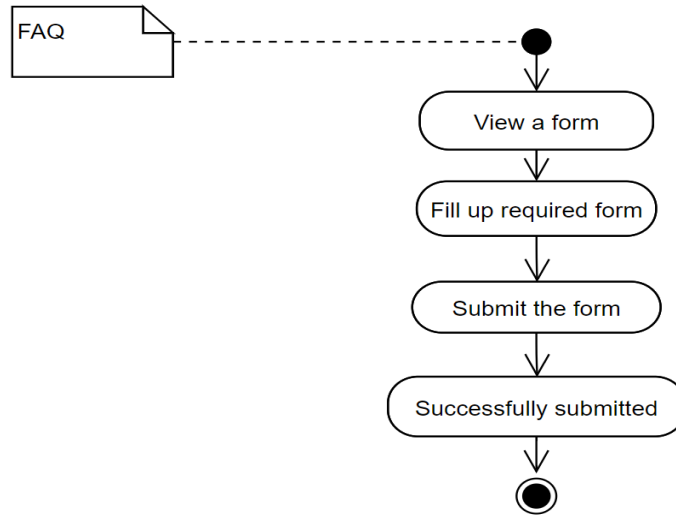

Figure 3.25: Activity Diagram for FAQ

Figure 3.25 represents the FAQ for Activity. All the users can ask any question by submitting a form with providing email.

3.2 Sequence Diagram

I have separated the Sequence Diagram according to the working issue.

3.4.1 Property Issue for Owner, Tenant and

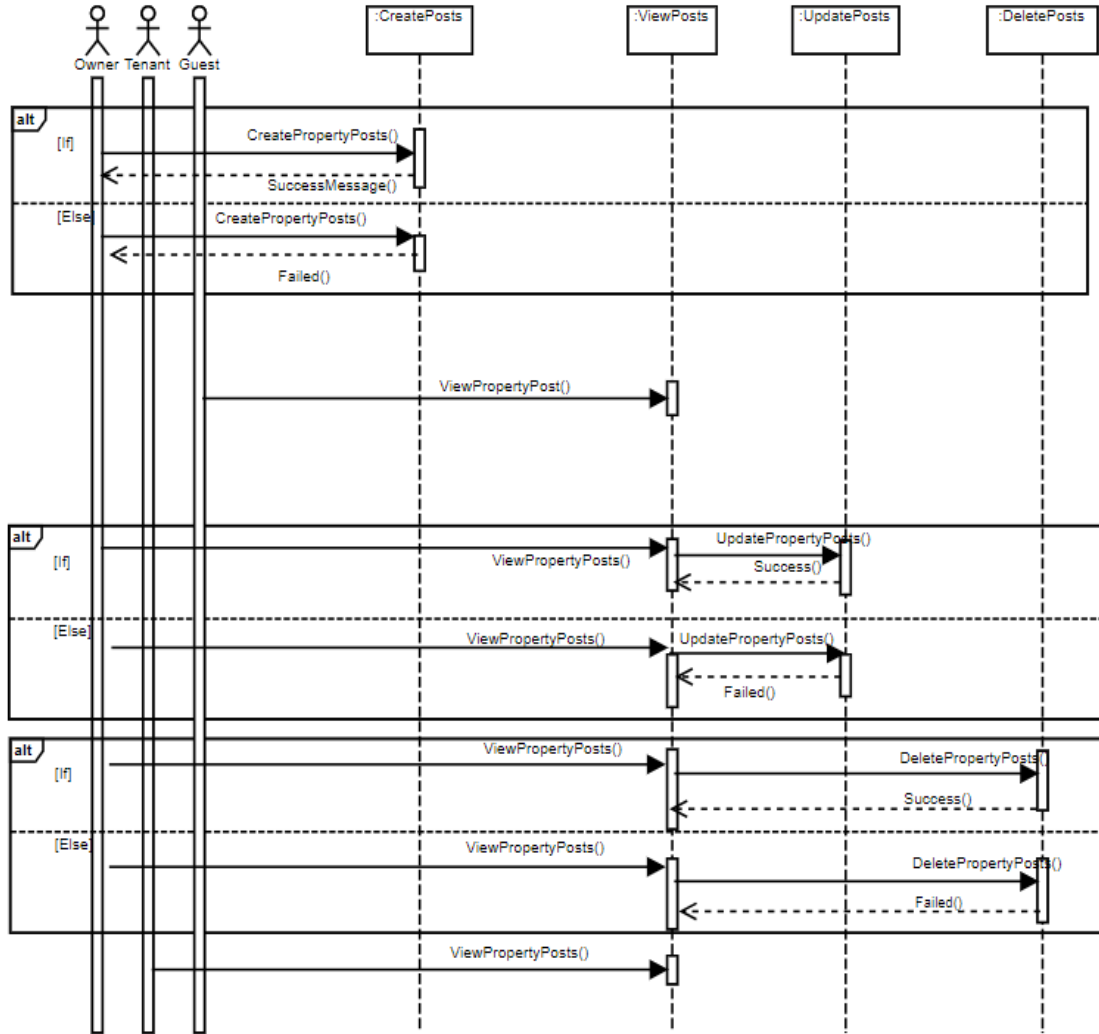

Figure 3.26: Property Issue for Owner, Tenant and Guest

Figure 3.26 represents the Property Issue for Owner, Tenant and Guest. I have tried to show the interaction between the objects and the users. It describes how and in what order the objects in a system function.

3.4.2 Property Issue for Admin

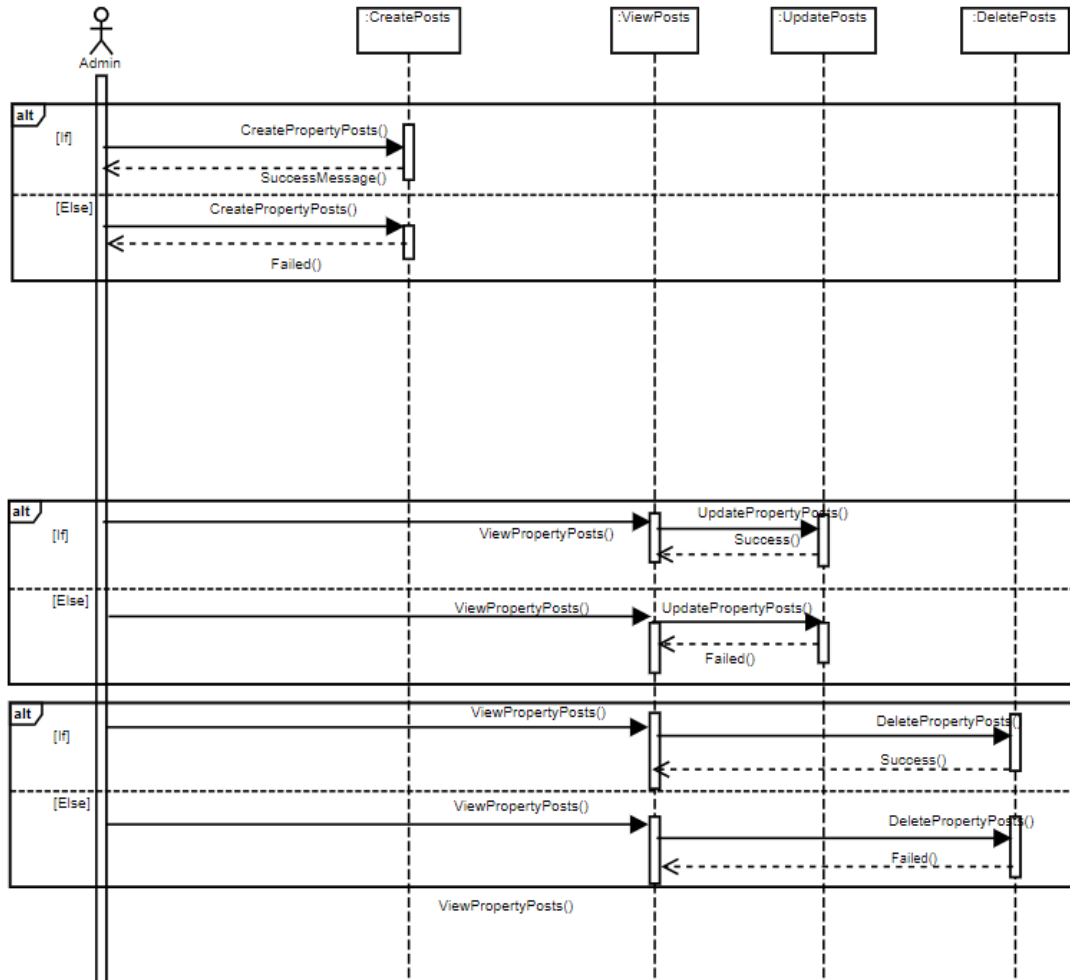

Figure 3.27: Property Issue for Admin

Figure 3.27 represents the Property Issue for Admin. I have tried to show the interaction between the objects and the users. It describes how and in what order the objects in a system function.

3.4.3 Necessity Issue for Tenant, Owner and Guest

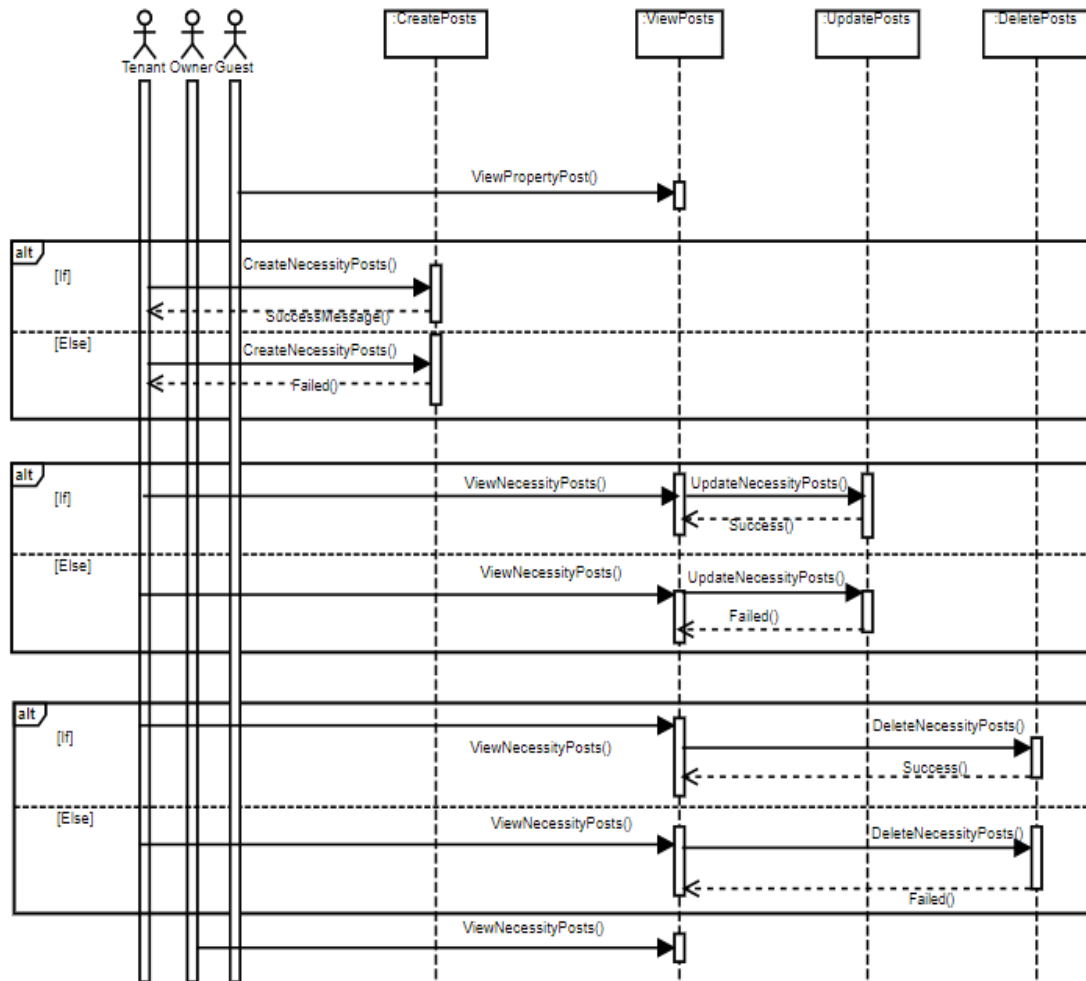

Figure 3 28: Necessity Issue for Tenant, Owner and Guest

Figure 3.28 represents the Necessity Issue for Owner, Tenant and Guest. I have tried to show the interaction between the objects and the users. It describes how and in what order the objects in a system function.

3.4.4 Necessity Issue for Admin

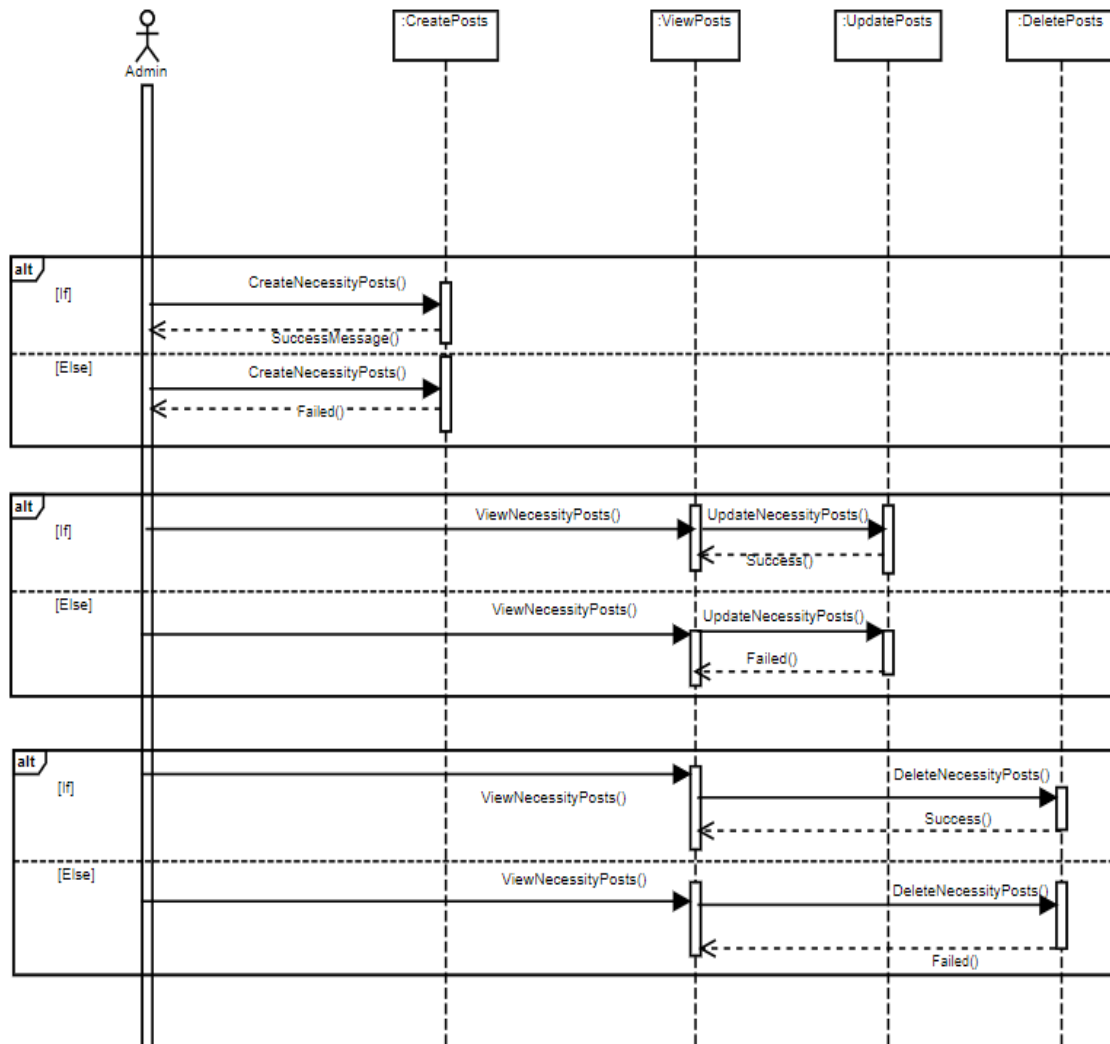

Figure 3 29: Necessity Issue for Admin

Figure 3.29 represents the Necessity Issue for Admin. I have tried to show the interaction between the objects and the users. It describes how and in what order the objects in a system function.

3.4.5 Area Guide Issue

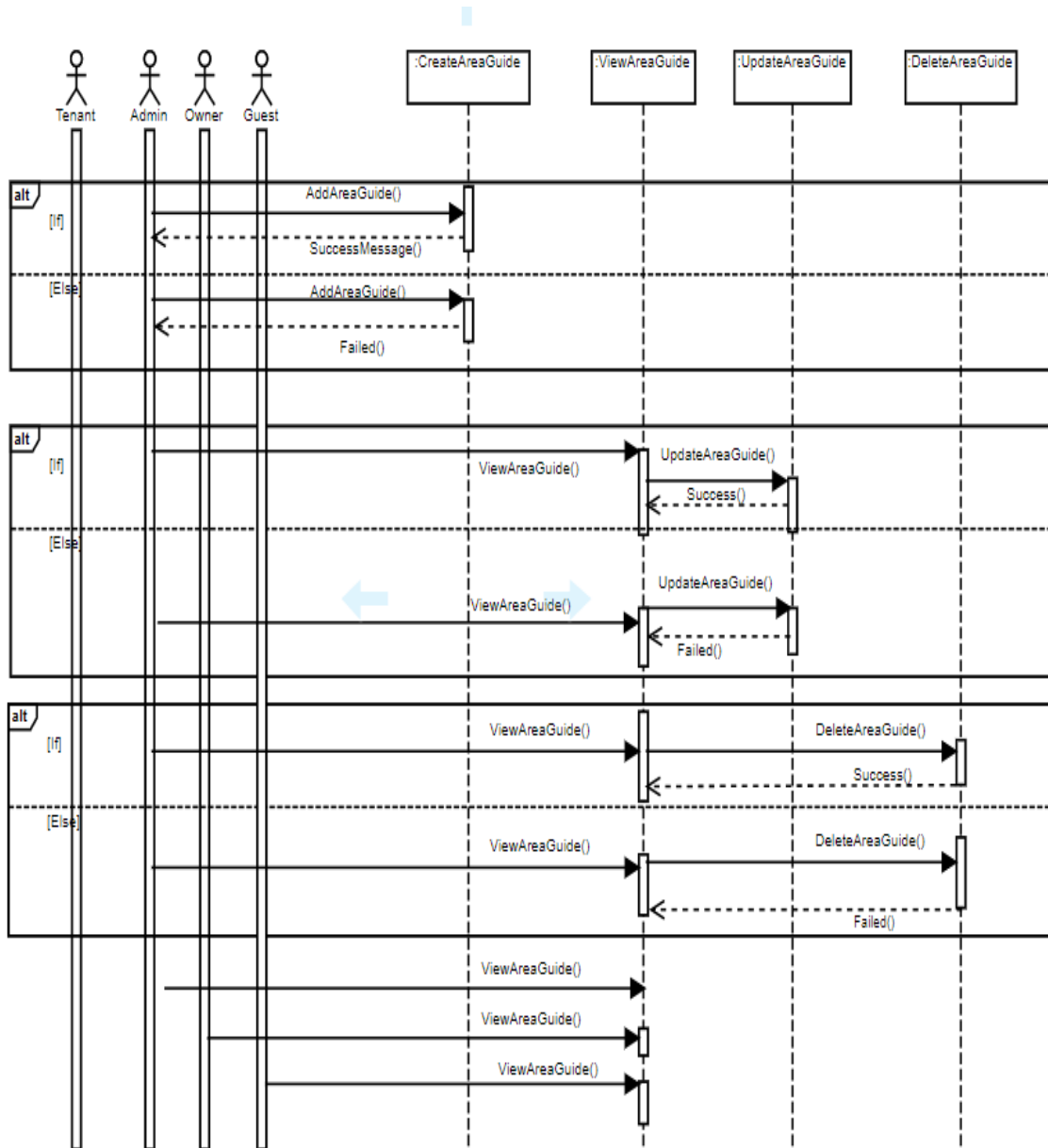

Figure 3 30: Area Guide Issue

Figure 3.30 represents the Area Guide Issue for Owner, Tenant, Guest and Admin. I have tried to show the interaction between the objects and the users. It describes how and in what order the objects in a system function.

3.4.6 Area Blog Issue

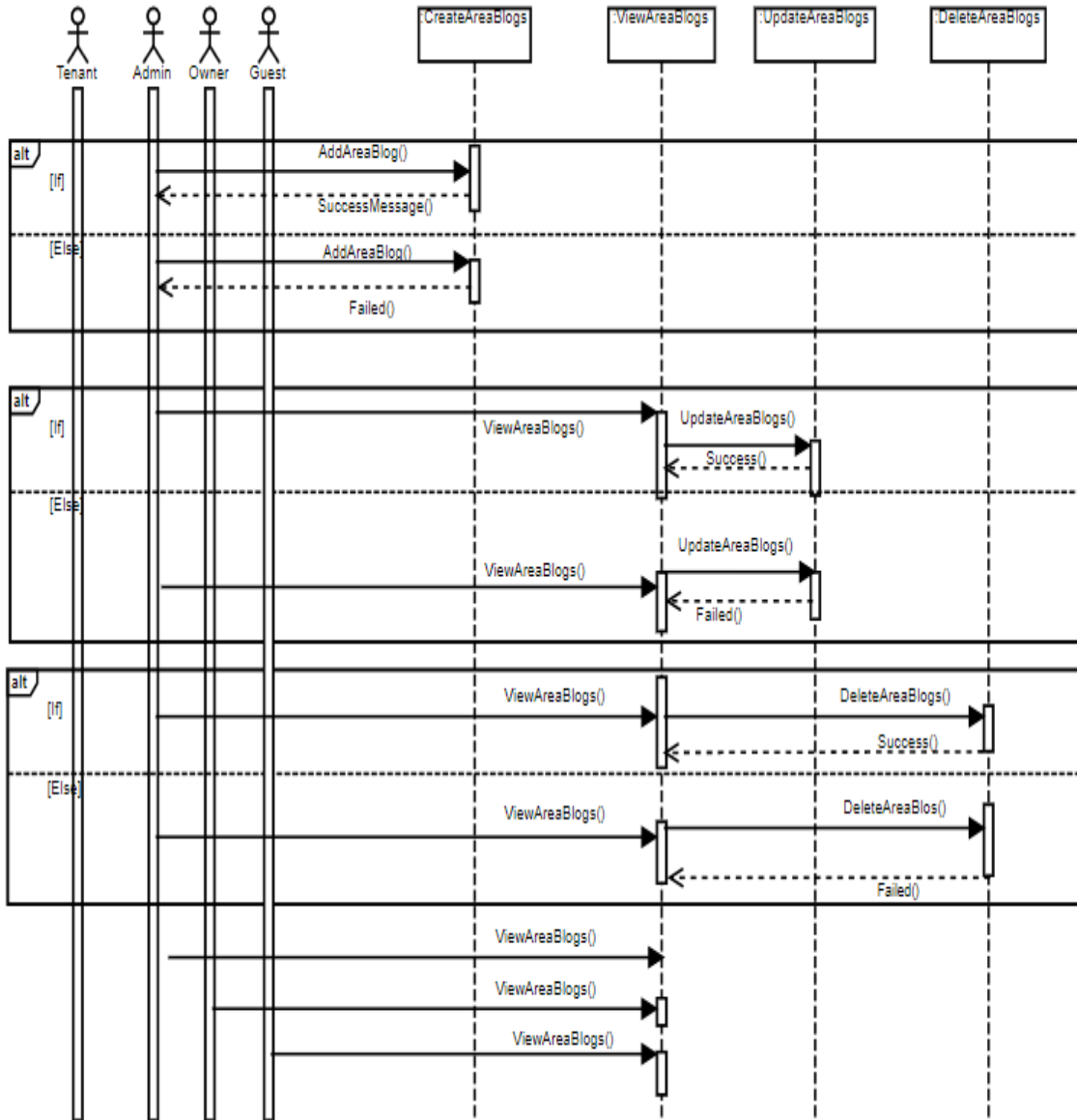

Figure 3.31: Area Blog Issue

Figure 3.31 represents the Area Blog Issue for Owner, Tenant, Guest and Admin. I have tried to show the interaction between the objects and the users. It describes how and in what order the objects in a system function.

CHAPTER 4

SYSTEM DESIGN SPECIFICATION

4.1 Development Tools and Technology

4.1.1 User Interface Technology

User Interface is the process to build interfaces in software or computerized devices, web developments, focusing on looks or style. In my project which technologies I have used to design interface are given below-

- i HTML
- ii CSS
- iii Bootstrap
- iv JavaScript
- v PHP

4.1.2 Implementation Tools and Platform

- i Xampp
- ii Composer
- iii Git Bash
- iv Laravel

4.1 Entity Relationship Diagram

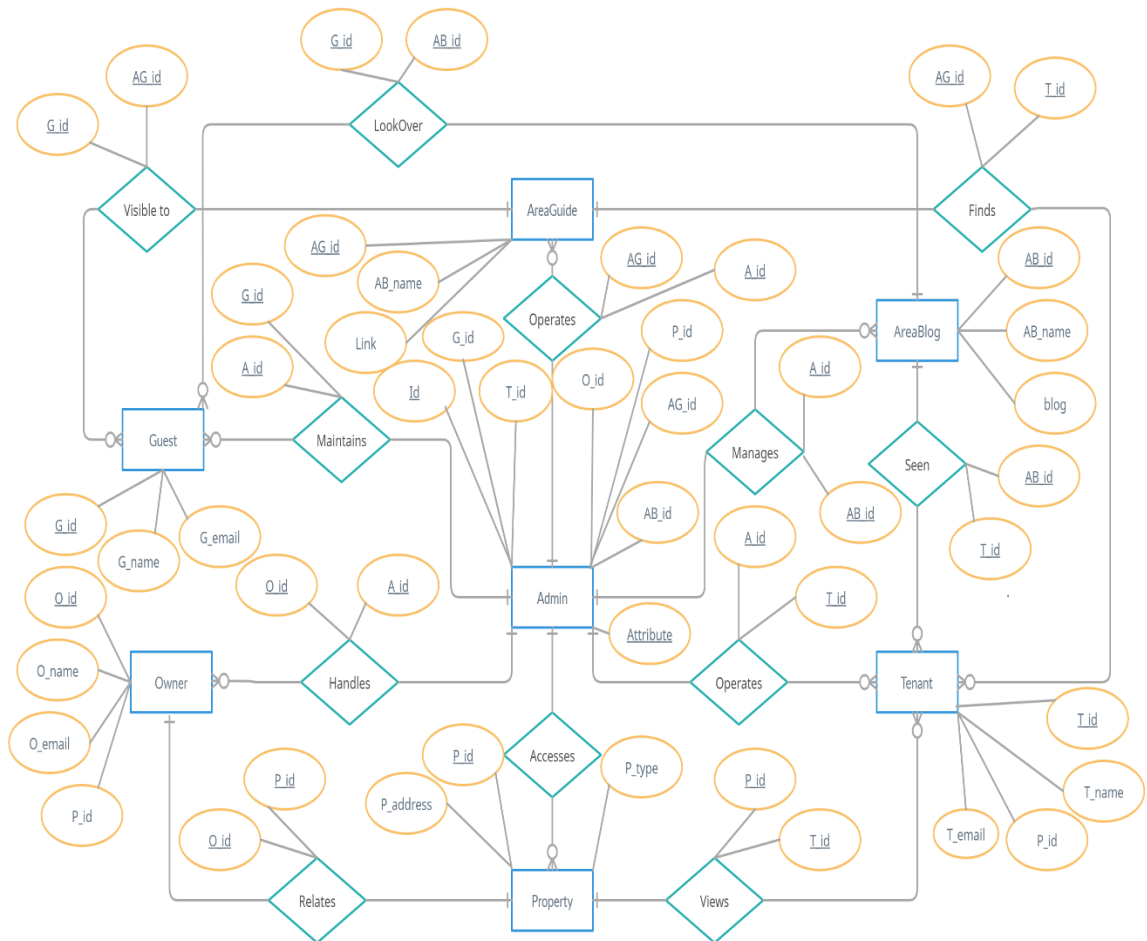

Figure 4.1: Entity Relationship Diagram for Digital To-let System (DTS)

Figure 4.1 represents the ERD for DTS. In this Diagram, there are seven entity related with each other based on Cardinality.

4.2 Class Diagram

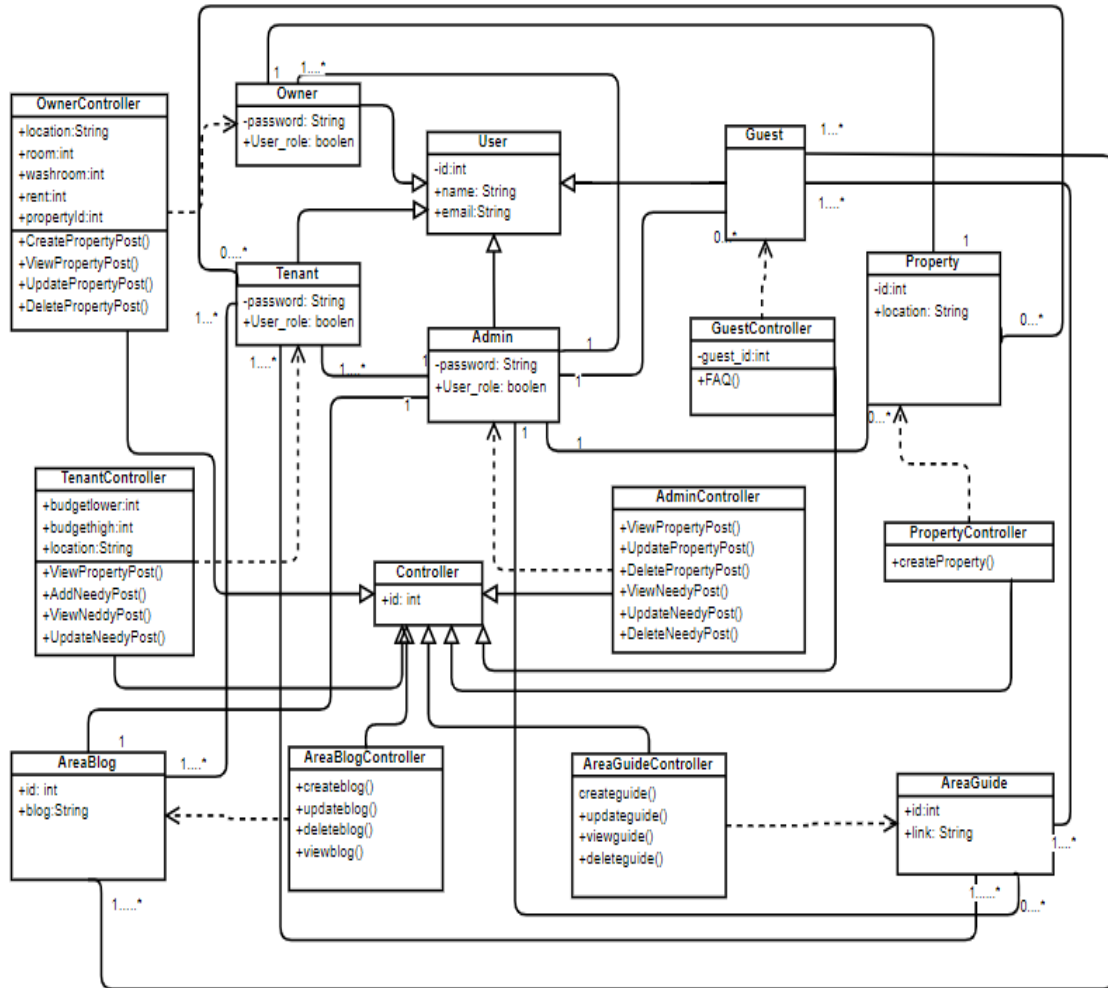

Figure 4.2: Class diagram for Digital To-let System

Figure 4.2 represents Class Diagram for DTS. In this diagram, I have used classes with attributes and operations. I have also used the association, inheritance and dependency to make it easier for the users.

CHAPTER 5
SYSTEM TEST

5.1 Testing Features

Priority Level

1 = Low Priority

2 = Medium Priority

3 = High Priority

5.1.1 Owner's features

Features	Priority	Description
Registration	3	System must validate the user
Login	3	Authenticate user should be logged in
Create Property Post	3	Owner can create property post with valid data
View Property Post	3	Owner can view his own property post
Update Property post	3	Owner can successfully update his property post
Delete Property Post	3	Owner can delete his own property post
View Necessity post	2	Owner can able to see the tenant necessity post

5.1.2 Guest's features

Features	Priority	Description
View Area Guide	2	Guests users have the access to see the area guide
View Area Blog	2	Guests users have the access to see the area blog
FAQ	3	It is mandatory for the users to ask any question to the system admin by providing email address

5.1.3 Admin features

Features	Priority	Description
Registration	3	System must validate the user
Login	3	Authenticate user should be logged in
View Property Post	3	Admin can view property post
Update Property post	3	Admin can successfully update property post
Delete Property Post	3	Admin can delete property post
View Necessity Post	2	Admin can view necessity post
Update Necessity Post	3	Admin can update necessity post
Delete Necessity Post	3	Admin can delete necessity post
Add Area Guide	3	Admin can add area guide
View Area Guide	3	Admin can view area guide
Edit Area Guide	3	Admin can edit area guide
Delete Area Guide	3	Admin can delete area guide
Add Area Blog	3	Admin can add area blog
View Area Blog	3	Admin can view area blog
Edit Area Blog	3	Admin can edit area blog
Delete Area Blog	3	Admin can delete area blog
View FAQ	3	Admin can View FAQ

5.1.4 Tenant features

Features	Priority	Description
Registration	3	System must validate the user
Login	3	Authenticate user should be logged in
Create Necessity Post	3	Tenant can create necessity post with valid data
View Necessity Post	3	Tenant can view his own necessity post
Update Necessity post	3	Tenant can successfully update his necessity post
Delete necessity Post	3	Tenant can delete his own necessity post
View Property post	3	Tenant can able to see the property post
View Area Guide	2	Tenant can see the area guide
View Area Blog	2	Tenant can see the area blog

5.2 Requirements Traceability Matrix

Project Manager:			Business Analyst Lead:		
QA Lead:			Target Implementation Date:		
BR#	Requirement Description	Actor	Use Case Reference	Test Case Reference	Comments
BR-01	Registration	Owner, Tenant, Admin	3.2.1	5.3.1	
BR-02	Login	Owner, Tenant, Admin	3.2.2	5.3.2	
BR-03	Select user-role	Owner, Tenant, Admin	3.2.3	5.3.3	
BR-04	Create property post	Owner	3.2.4	5.3.4	
BR-05	View property post	Owner, Tenant, Admin	3.2.5	5.3.5	
BR-06	Update property post	Owner, Admin	3.2.6	5.3.6	
BR-07	Delete property post	Owner, Admin	3.2.7	5.3.7	
BR-08	Create necessity post	Tenant	3.2.8	5.3.8	
BR-09	View necessity post	Tenant, Admin, Owner	3.2.9	5.3.9	
BR-10	Update necessity post	Tenant, Admin	3.2.10	5.3.10	

BR-11	Delete necessity post	Tenant, Admin	3.2.11	5.3.11	
BR-12	Add area guide	Admin	3.2.12	5.3.12	
BR-13	View area guide	Tenant, Admin, Guest	3.2.13	5.3.13	
BR-14	Edit area guide	Admin	3.2.14	5.3.14	
BR-15	Delete area guide	Admin	3.2.15	5.3.15	
BR-16	Add area blog	Admin	3.2.16	5.3.16	
BR-17	View Area blog	Admin, Tenant, Guest	3.2.17	5.3.17	
BR-18	Update area blog	Admin	3.2.18	5.3.18	
BR-19	Delete area blog	Admin	3.2.19	5.3.19	
BR-20	FAQ	Admin, Guest	3.2.20	5.3.20	
BR-21	Logout	Admin, Owner, Tenant	3.2.21	5.3.21	

5.3 Black Box Testing with Test Cases

As we know, Black box testing is the process of test a software system without view the code. It just tests the application system using input valid and invalid. That's why I have used that.

5.3.1 Registration

Test Case: 5.3.1		Test Case Name: Registration			
System: Digital To-Let System		Subsystem:			
Designed by: Nijhum Sultana		Design Date:			
Executed by:		Execution Date:			
Description: Unregistered users can register for the system access.					
Pre-condition:					
<ul style="list-style-type: none"> Email address must be unique Password must be 8 characters 					
Step	Email	Password	Response	Pass/Fail	Comment
1	nijhum@gmail.com	12345678	Registration Successful	Pass	
2	nijhum@gmail.com	12345678	Invalid email	Fail	
3	nijhum@gmail.com	1234	Password must contain 6 characters	Fail	
Post-condition: A new user account has been registered successfully					

5.3.2 Login

Test Case: 5.3.2		Test Case Name: Login			
System: Digital To-Let System		Subsystem:			
Designed by: Nijhum Sultana		Design Date:			
Executed by:		Execution Date:			
Description: Registered users can Login for the system access.					
Pre-condition:					
<ul style="list-style-type: none"> Registration Successful 					
Step	Email	Password	Response	Pass/Fail	Comment
1	nijhum@gmail.com	12345678	Registration successful	Pass	
2	mou@gmail.com	12345678	Invalid email	Fail	
3	nijhum@gmail.com	1234	Password must contain 6 characters	Fail	
Post-condition: A new user account has been registered successfully					

5.3.3 Select User-role

Test Case: 5.3.3		Test Case Name: Select User-role		
System: Digital To-Let System		Subsystem:		
Designed by: Nijhum Sultana		Design Date:		
Executed by:		Execution Date:		
Description: Users can Select role for role.				
Pre-condition:				
<ul style="list-style-type: none"> N/A 				
Step	role	Response	Pass/Fail	Comment
1	Tenant	Successful	Pass	
2	Owner	Successful	Pass	
3	Admin	Successful	Pass	
4	Null	Please select user- role	Fail	
Post-condition: A user can select User-role				

5.3.4 Create Property Post

Test Case: 5.3.4		Test Case Name: Create Property Post		
System: Digital To-Let System		Subsystem:		
Designed by: Nijhum Sultana		Design Date:		
Executed by:		Execution Date:		
Description: Authenticate User can Create Property Post				
Pre-condition:				
<ul style="list-style-type: none"> Login to the system 				
Step	Form fill-up	Response	Pass/ Fail	Comment
1	Users fill-up the required form properly	Submitted	Pass	
2	Users fill-up the required form except one/more field	All field must be required	Fail	
Post-condition: Property post should be created Successfully				

5.3.5 View Property Post

Test Case: 5.3.5		Test Case Name: View Property Post		
System: Digital To-Let System		Subsystem:		
Designed by: Nijhum Sultana		Design Date:		
Executed by:		Execution Date:		
Description: Authenticate user can view the Property posts				
Pre-condition:				
<ul style="list-style-type: none"> • Login to the system • Property post must be created 				
Step	Action	Response	Pass/ Fail	Comment
1	Click on “View Property” Button	View Property	Pass	
Post-condition: Users can view Property post successfully				

5.3.6 Update Property Post

Test Case: 5.3.6		Test Case Name: Update Property Post		
System: Digital To-Let System		Subsystem:		
Designed by: Nijhum Sultana		Design Date:		
Executed by:		Execution Date:		
Description: Authenticate User can Update Property Post				
Pre-condition:				
<ul style="list-style-type: none"> • Login to the system • Property Post must be created 				
Step	Action	Response	Pass/ Fail	Comment
1	Update Some Info	Updated	Pass	
2	Update Nothing	Nothing Updated	Pass	
Post-condition: Property post should be updated successfully				

5.3.7 Delete Property Post

Test Case: 5.3.5		Test Case Name: Delete Property Post		
System: Digital To-Let System		Subsystem:		
Designed by: Nijhum Sultana		Design Date:		
Executed by:		Execution Date:		
Description: Authenticate User can successfully delete Property Post				
Pre-condition:				
<ul style="list-style-type: none"> • Login to the system • Create property post 				
Step	Action	Response	Pass/ Fail	Comment
1	Click on “Delete Property” Button	Deleted	Pass	
Post-condition: Users can view Property post successfully				

5.3.8 Create Necessity Post

Test Case: 5.3.8		Test Case Name: Create Necessity Post		
System: Digital To-Let System		Subsystem:		
Designed by: Nijhum Sultana		Design Date:		
Executed by:		Execution Date:		
Description: Authenticate User can Create Necessity Post				
Pre-condition:				
<ul style="list-style-type: none"> Login to the system 				
Step	Form fill-up	Response	Pass/ Fail	Comment
1	Users fill-up the required form properly	Submitted	Pass	
2	Users fill-up the required form except one/more field	All field must be required	Fail	
Post-condition: Necessity post should be created Successfully				

5.3.9 View Necessity Post

Test Case: 5.3.9		Test Case Name: View Necessity Post		
System: Digital To-Let System		Subsystem:		
Designed by: Nijhum Sultana		Design Date:		
Executed by:		Execution Date:		
Description: Authenticate user can view the Necessity posts				
Pre-condition:				
<ul style="list-style-type: none"> • Login to the system • Necessity post must be created 				
Step	Action	Response	Pass/ Fail	Comment
1	Click on “View Necessity” Button	View necessity	Pass	
Post-condition: Users can view Necessity post successfully				

5.3.10 Update Necessity Post

Test Case: 5.3.10		Test Case Name: Update Necessity Post		
System: Digital To-Let System		Subsystem:		
Designed by: Nijhum Sultana		Design Date:		
Executed by:		Execution Date:		
Description: Authenticate User can Update Necessity Post				
Pre-condition:				
<ul style="list-style-type: none"> • Login to the system • Property Post must be created 				
Step	Action	Response	Pass/ Fail	Comment
1	Update Some Info	Updated	Pass	
2	Update Nothing	Nothing Updated	Pass	
Post-condition: Necessity post should be updated successfully				

5.3.11 Delete Necessity Post

Test Case: 5.3.11		Test Case Name: Delete necessity Post		
System: Digital To-Let System		Subsystem:		
Designed by: Nijhum Sultana		Design Date:		
Executed by:		Execution Date:		
Description: Authenticate user can delete necessity post successfully.				
Pre-condition:				
<ul style="list-style-type: none"> • Login to the system • Create property post 				
Step	Action	Response	Pass/ Fail	Comment
1	Click on “Delete Property”	Deleted	Pass	
Post-condition: Users can delete Necessity post successfully				

5.3.12 Add Area Guide

Test Case: 5.3.12		Test Case Name: Add Area Guide		
System: Digital To-Let System		Subsystem:		
Designed by: Nijhum Sultana		Design Date:		
Executed by:		Execution Date:		
Description: Admin can Add Area guide successfully				
Pre-condition:				
<ul style="list-style-type: none"> Login to the system 				
Step	Form fill-up	Response	Pass/ Fail	Comment
1	Users fill-up the required form properly	Submitted	Pass	
2	Users fill-up the required form except one/more field	All field must be required	Fail	
Post-condition: Area Guide should be created Successfully				

5.3.13 View Area Guide

Test Case: 5.3.13		Test Case Name: View Area Guide		
System: Digital To-Let System		Subsystem:		
Designed by: Nijhum Sultana		Design Date:		
Executed by:		Execution Date:		
Description: Authenticate user can view the Area Guide				
Pre-condition:				
<ul style="list-style-type: none"> • Login to the system • Area guide must be created 				
Step	Action	Response	Pass/ Fail	Comment
1	Click on “View Area guide” Button	View Area Guide	Pass	
Post-condition: Users can view Area guide successfully				

5.3.14 Update Area Guide

Test Case: 5.3.14		Test Case Name: Update Area Guide		
System: Digital To-Let System		Subsystem:		
Designed by: Nijhum Sultana		Design Date:		
Executed by:		Execution Date:		
Description: Authenticate User can Update Area Guide				
Pre-condition:				
<ul style="list-style-type: none"> • Login to the system • Area guide must be created 				
Step	Action	Response	Pass/ Fail	Comment
1	Update Some Info	Updated	Pass	
2	Update Nothing	Nothing Updated	Pass	
Post-condition: Area guide should be updated successfully				

5.3.15 Delete Area Guide

Test Case: 5.3.15		Test Case Name: Delete Area Guide		
System: Digital To-Let System		Subsystem:		
Designed by: Nijhum Sultana		Design Date:		
Executed by:		Execution Date:		
Description: Authenticate user can delete Area guide successfully.				
Pre-condition:				
<ul style="list-style-type: none"> • Login to the system • Create Area guide 				
Step	Action	Response	Pass/ Fail	Comment
1	Click on “Delete Area Guide” Button	Deleted	Pass	
Post-condition: Users can delete Area Guide successfully				

5.3.16 Add Area Blog

Test Case: 5.3.16		Test Case Name: Add Area Blog		
System: Digital To-Let System		Subsystem:		
Designed by: Nijhum Sultana		Design Date:		
Executed by:		Execution Date:		
Description: Admin can Add Area blog successfully				
Pre-condition:				
<ul style="list-style-type: none"> Login to the system 				
Step	Form fill-up	Response	Pass/ Fail	Comment
1	Users fill-up the required form properly	Submitted	Pass	
2	Users fill-up the required form except one/more field	All field must be required	Fail	
Post-condition: Area blog should be created Successfully				

5.3.17 View Area Blog

Test Case: 5.3.17		Test Case Name: View Area Blog		
System: Digital To-Let System		Subsystem:		
Designed by: Nijhum Sultana		Design Date:		
Executed by:		Execution Date:		
Description: Authenticate user can view the Area Blog				
Pre-condition:				
<ul style="list-style-type: none"> • Login to the system • Area blog must be created 				
Step	Action	Response	Pass/ Fail	Comment
1	Click on “View Area blog” Button	View Area Blog	Pass	
Post-condition: Users can view Area Blog successfully				

5.3.18 Edit Area Blog

Test Case: 5.3.18		Test Case Name: Update Area Blog		
System: Digital To-Let System		Subsystem:		
Designed by: Nijhum Sultana		Design Date:		
Executed by:		Execution Date:		
Description: Authenticate User can Update Area Blog				
Pre-condition:				
<ul style="list-style-type: none"> • Login to the system • Area blog must be created 				
Step	Action	Response	Pass/ Fail	Comment
1	Update Some Info	Updated	Pass	
2	Update Nothing	Nothing Updated	Pass	
Post-condition: Area blog should be updated successfully				

5.3.19 Delete Area Blog

Test Case: 5.3.19		Test Case Name: Delete Area Blog		
System: Digital To-Let System		Subsystem:		
Designed by: Nijhum Sultana		Design Date:		
Executed by:		Execution Date:		
Description: Authenticate user can delete Area blog successfully.				
Pre-condition:				
<ul style="list-style-type: none"> • Login to the system • Create Area blog 				
Step	Action	Response	Pass/ Fail	Comment
1	Click on “Delete Area Blog” Button	Deleted	Pass	
Post-condition: Users can delete Area blog successfully				

5.3.20 FAQ

Test Case: 5.3.20		Test Case Name: FAQ		
System: Digital To-Let System		Subsystem:		
Designed by: Nijhum Sultana		Design Date:		
Executed by:		Execution Date:		
Description: Users can Ask any question to the Admin				
Pre-condition:				
<ul style="list-style-type: none"> N/A 				
Step	Form fill-up	Response	Pass/ Fail	Comment
1	Users fill-up the required form properly	Submitted	Pass	
2	Users fill-up the required form except one/more field	All field must be required	Fail	
Post-condition: FAQ should be sent to Admin Successfully				

5.3.21 Logout

Test Case: 5.3.21		Test Case Name: Log Out		
System: Digital To-let System		Subsystem:		
Designed by: Nijhum Sultana		Design Date:		
Executed by:		Execution Date:		
Description: Registered members can log out from their dashboard and end session				
Pre-condition:				
<ul style="list-style-type: none"> The member must be logged in 				
Step	Action	Response	Pass/Fail	Comment
1	Member clicks on “Log Out” button	System will end the session and bring the user to the “Home” page	Pass	
Post-condition: Member logs out from their dashboard				

CHAPTER 6

USER MANUAL

6.1 Home Page

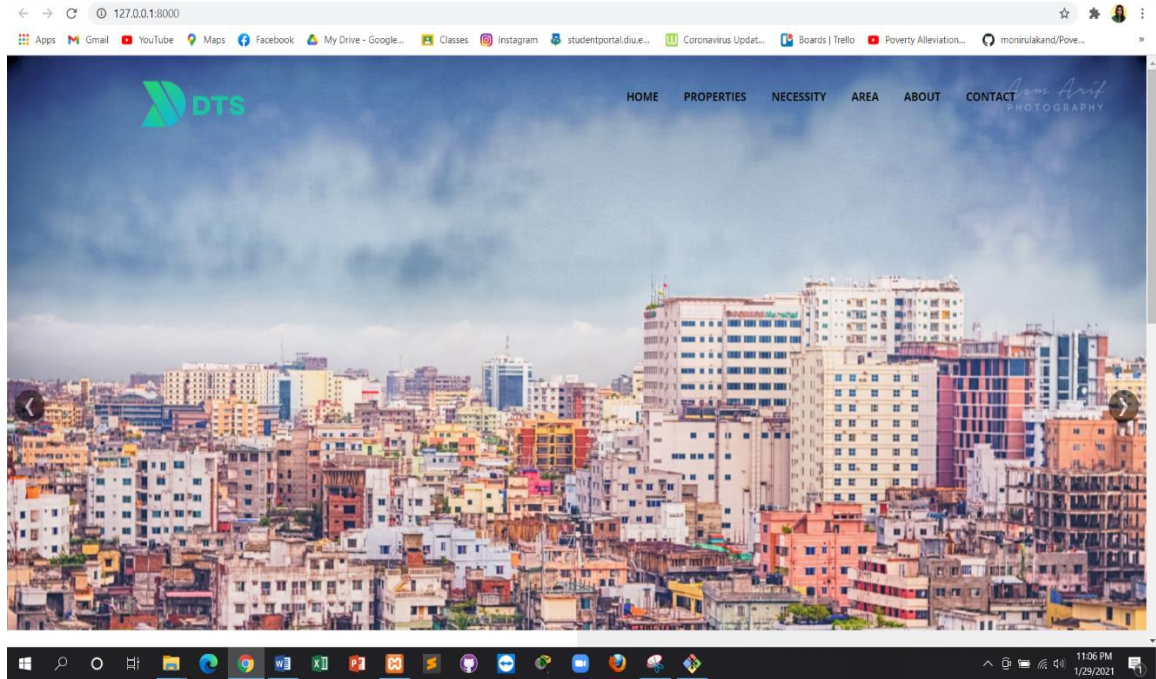

Figure 6.1: Home page

6.2 Property for Guest

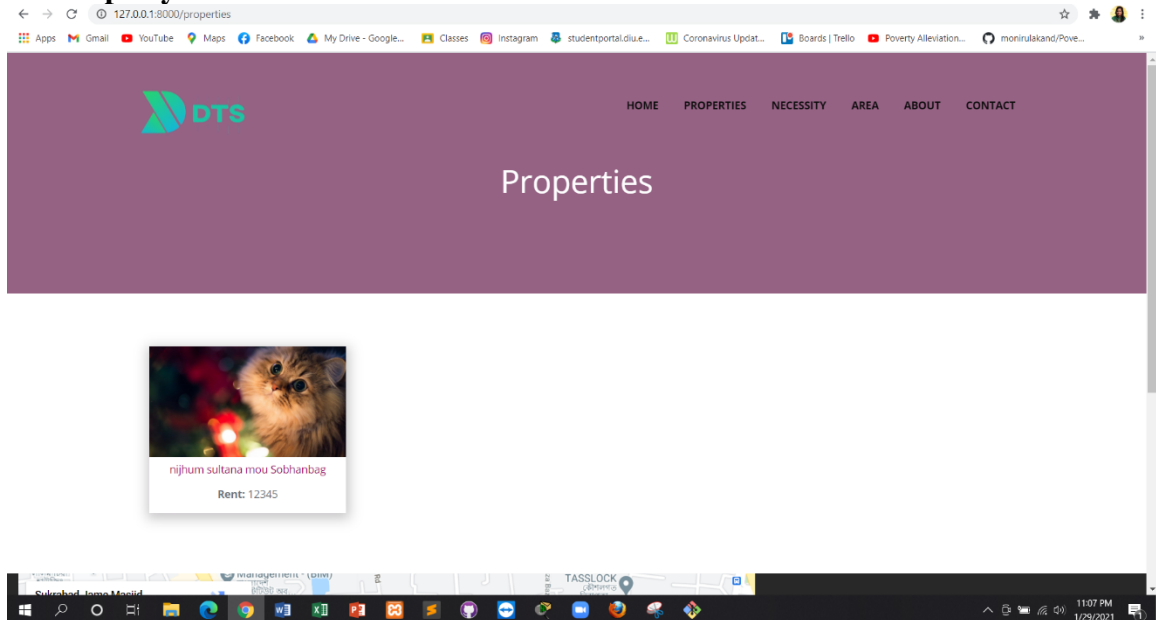

Figure 6.2: Property for Guest

6.3 Necessity for Guest

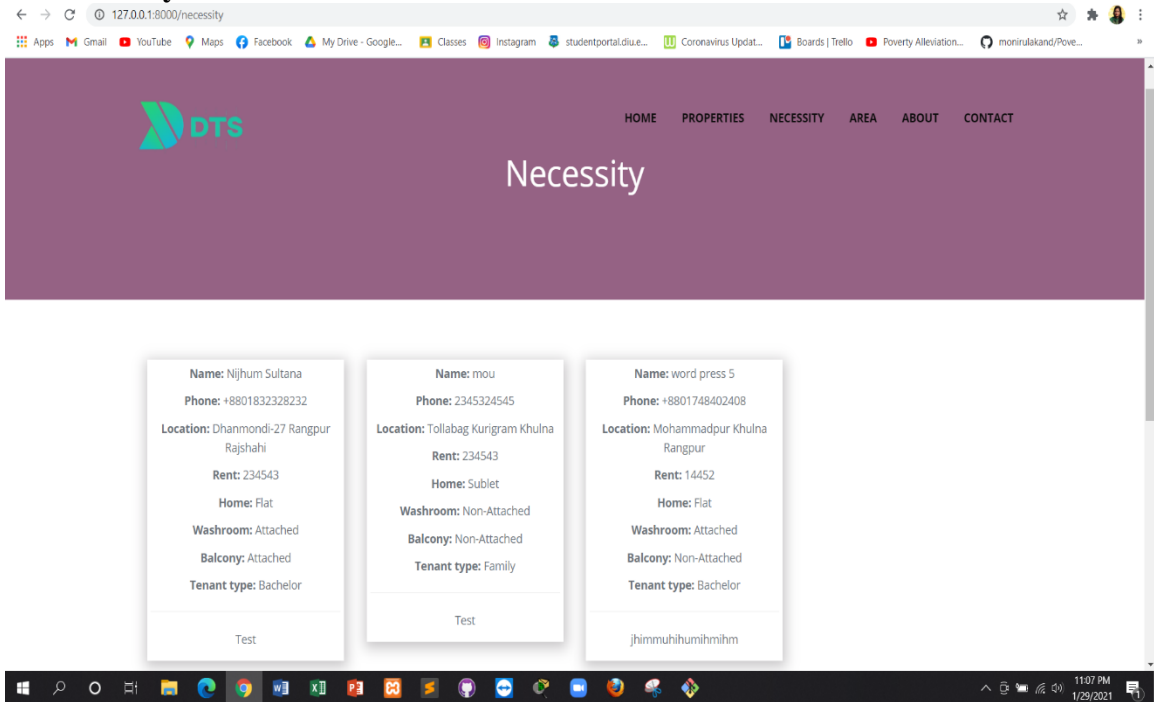

Figure 6.3: Necessity for Guest

6.4 Area Guide

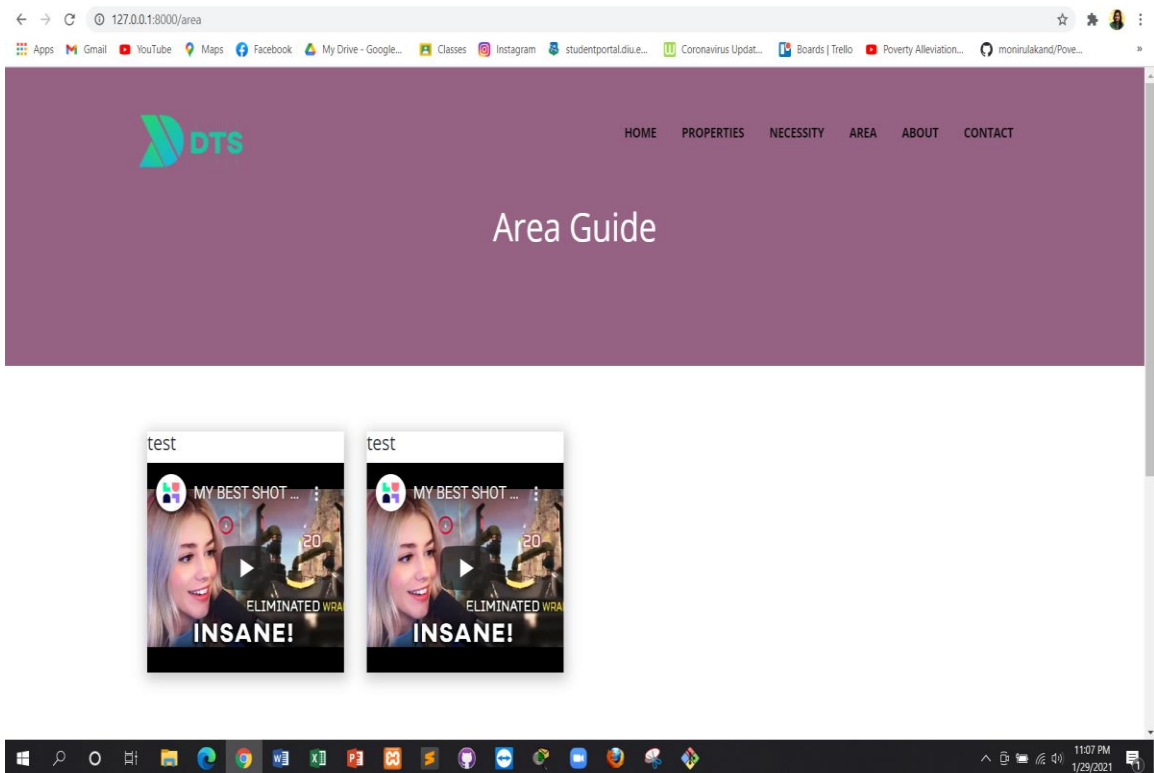

Figure 6.4: Area Guide

6.5 About Us

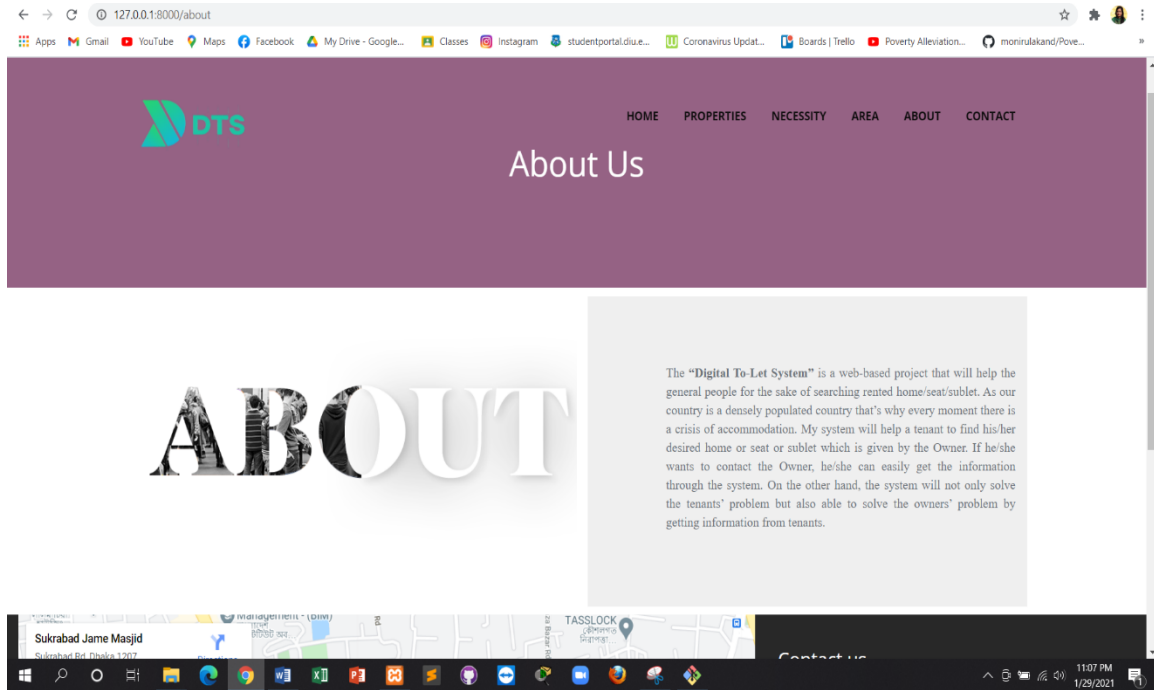

Figure 6.5: About Us

6.6 Contact Us

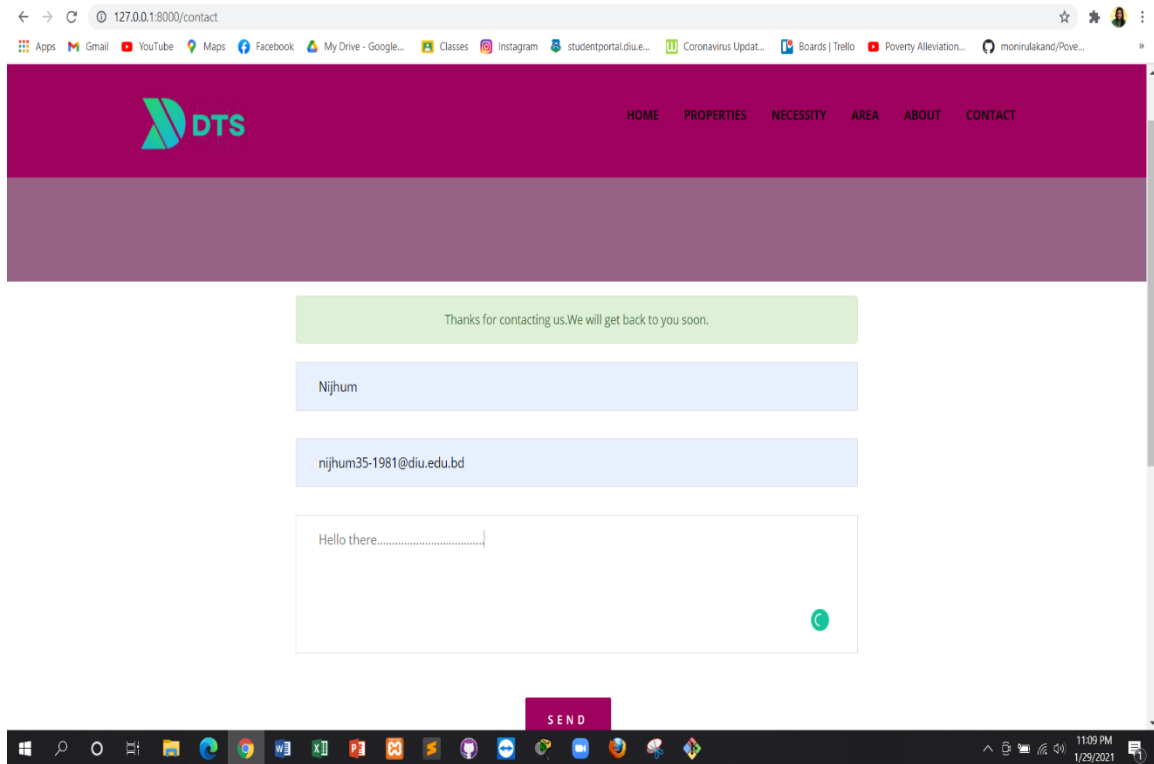

Figure 6.6: Contact Us

6.7 Registration Page

The screenshot shows a web browser window with the address bar displaying '127.0.0.1:8000/register'. The page content includes a navigation bar with 'Laravel' on the left and 'Login Register' on the right. The main content area features a 'Register' form with the following fields: 'Name' (filled with 'Nijhum Mou'), 'E-Mail Address' (filled with 'nijhumou@gmail.com'), 'Role' (a dropdown menu showing 'Tenant'), 'Password' (masked with dots), and 'Confirm Password' (masked with dots). A blue 'Register' button is positioned below the 'Confirm Password' field. The Windows taskbar at the bottom shows the time as 11:16 PM on 1/29/2021.

Figure 6.7: Registration Page

6.8 Login Page

The screenshot shows a web browser window with the address bar displaying '127.0.0.1:8000/login'. The page content includes a navigation bar with 'Laravel' on the left and 'Login Register' on the right. The main content area features a 'Login' form with the following fields: 'E-Mail Address' (filled with 'nijhumsultana007@gmail.com') and 'Password' (masked with dots). Below the password field is a 'Remember Me' checkbox. A blue 'Login' button is positioned below the 'Remember Me' checkbox, and a 'Forgot Your Password?' link is located to the right of the button. The Windows taskbar at the bottom shows the time as 11:16 PM on 1/29/2021.

Figure 6.8: Login Page

6.9 Forget Password

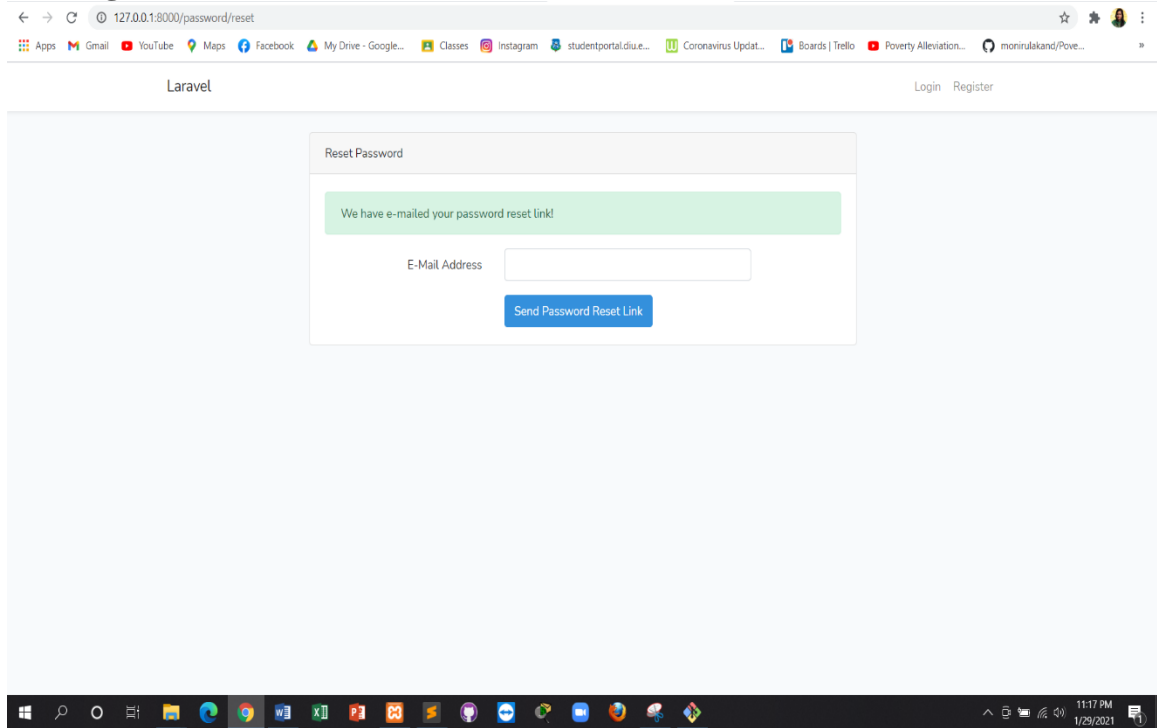

Figure 6.9: Forget Password

6.10 Admin Dashboard

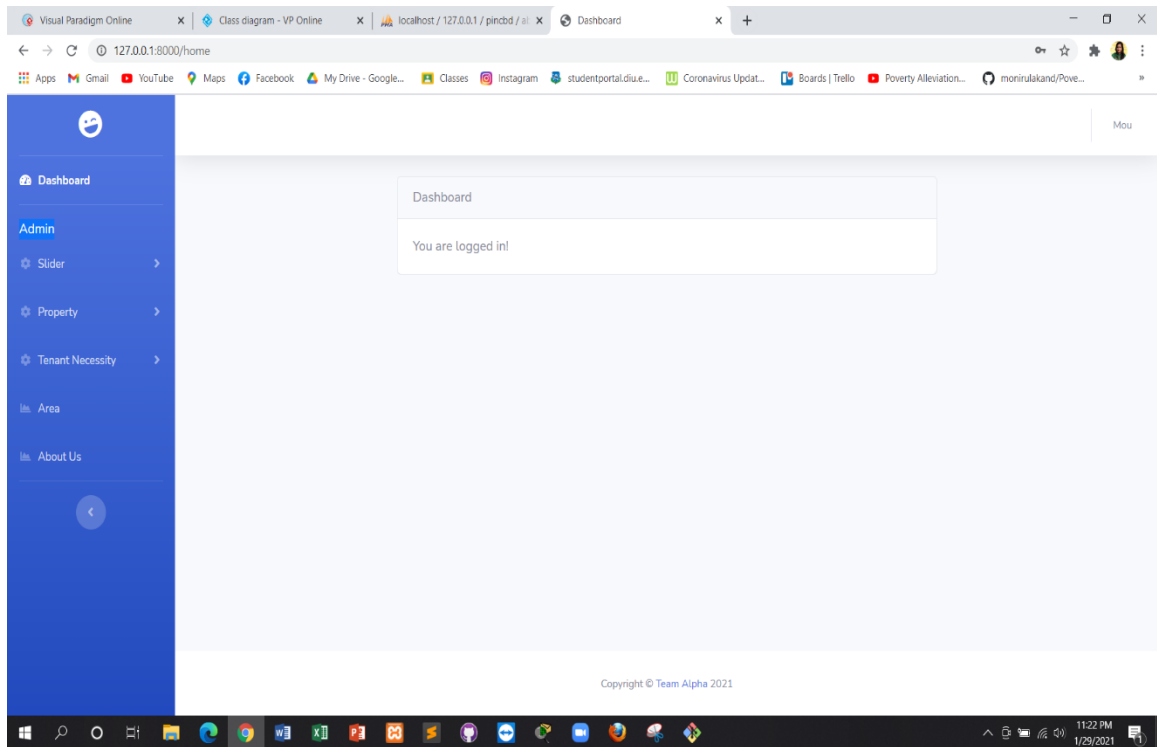

Figure 6.10: Admin Dashboard

6.11 Property view for Admin

Property

Show 10 entries Search:

Owner Name	Modile No	Division	District	Location	Tenant Type	Lift	Rent	Room-Quantity	Washroom-Quantity	Balcony-Quantity	F
nijhum sultana mou	+8801748402406	Rangpur	Bogura	Sobhanbag	Bachelor	yes	12345	2	2	2	2

Showing 1 to 1 of 1 entries Previous 1 Next

Copyright © Team Alpha 2021

Figure 6.11: Property view for Admin

6.12 Add Property for Admin

Property

Show 10 entries Search:

Owner Name	Modile No	Division	District	Location	Tenant Type	Lift	Rent	Room-Quantity	Washroom-Quantity	Balcony-Quantity	F
nijhum sultana mou	+8801748402406	Rangpur	Bogura	Sobhanbag	Bachelor	yes	12345	2	2	2	2
word press 5	+8801747402406	Mymensingh	Bogura	Sobhanbag	Bachelor	No	12345	1	1	1	1

Showing 1 to 2 of 2 entries Previous 1 Next

Copyright © Team Alpha 2021

Figure 6.12: Add Property for Admin

6.13 Update Property for Admin

Property updated successfully

Property

Show 10 entries Search:

Owner Name	Modile No	Division	District	Location	Tenant Type	Lift	Rent	Room-Quantity	Washroom-Quantity	Balcony-Quantity
nijhum sultana mou	+8801748402406	Rangpur	Khulna	Dhanmondi-32	Family	yes	22000	2	2	2
word press 5	+8801747402406	Mymensingh	Bogura	Sobhanbag	Bachelor	No	12345	1	1	1

Showing 1 to 2 of 2 entries Previous 1 Next

Copyright © Team Alpha 2021

Figure 6.13: Update Property for Admin

6.14 Delete Property for Admin

Property Deleted successfully

Property

Show 10 entries Search:

Owner Name	Modile No	Division	District	Location	Tenant Type	Lift	Rent	Room-Quantity	Washroom-Quantity	Balcony-Quantity	F
Nijhum Sultana	+8801748402406	Syhet	Khulna	Tollabag	Bachelor	No	12345	1	1	2	5

Showing 1 to 1 of 1 entries Previous 1 Next

Copyright © Team Alpha 2021

Figure 6.14: Delete Property for Admin

6.15 Necessity view for Admin

127.0.0.1:8000/admin/tenant/index

Dashboard

Admin

- Slider
- Property
- Tenant Necessity
- Area
- About Us

Tenant Necessity

Add New +

Search:

	Division	District	Location	Tenant Type	Budget	Home	Washroom	Balcony	Comment	Action
15	Khulna	Kurigram	Tollabag	Family	234543	Sublet	Non-Attached	Non-Attached	Test	Edit Delete
128232	Rajshahi	Rangpur	Dhanmondi-27	Bachelor	234543	Flat	Attached	Attached	Test	Edit Delete
102408	Rangpur	Khulna	Mohammadpur	Bachelor	14452	Flat	Attached	Non-Attached	jhimmuhihumihimih	Edit Delete

Previous 1 Next

Copyright © Team Alpha 2021

Figure 6.15: Necessity view for Admin

6.16 Add Necessity for Admin

127.0.0.1:8000/admin/tenant/index

Dashboard

Admin

- Slider
- Property
- Tenant Necessity
- Area
- About Us

Tenant Necessity

Add New +

✓ You Successfully added Necessity

Show 10 entries

Search:

Tenant Name	Phone	Division	District	Location	Tenant Type	Budget	Home	Washroom	Balcony	Comm
mou	2345324545	Khulna	Kurigram	Tollabag	Family	234543	Sublet	Non-Attached	Non-Attached	Test
Nadim Hasan	01745214586	Rajshahi	Kurigram	Badda	Bachelor	2244	Seat	Non-Attached	Non-Attached	nothing
Nijhum Sultana	+8801832328232	Rajshahi	Rangpur	Dhanmondi-27	Bachelor	234543	Flat	Attached	Attached	Test
word press 5	+8801748402408	Rangpur	Khulna	Mohammadpur	Bachelor	14452	Flat	Attached	Non-Attached	jhimmu

Showing 1 to 4 of 4 entries

Previous 1 Next

Figure 6.16: Add Necessity for Admin

6.17 Update Necessity for Admin

Tenant updated successfully

Tenant Necessity Add New +

Show 10 entries Search:

Tenant Name	Phone	Division	District	Location	Tenant Type	Budget	Home	Washroom	Balcony	Comment
mou	2345324545	Khulna	Kurigram	Tollabag	Family	234543	Sublet	Non-Attached	Non-Attached	Test
Nadim Hasan	01745214586	Rajshahi	Kurigram	Badda	Bachelor	2244	Seat	Non-Attached	Non-Attached	nothing
Nijhum Sultana	+8801832328232	Rajshahi	Rangpur	Dhanmondi-27	Bachelor	234543	Flat	Attached	Attached	Test
word press 5	+8801748402408	Barishal	Bogura	Tollabag	Bachelor	4622	Seat	Attached	Attached	tenant po

Showing 1 to 4 of 4 entries Previous 1 Next

Figure 6.17: Update Necessity for Admin

6.18 Delete Necessity for Admin

Property Deleted successfully

Tenant Necessity Add New +

Show 10 entries Search:

Tenant Name	Phone	Division	District	Location	Tenant Type	Budget	Home	Washroom	Balcony	Comment
mou	2345324545	Khulna	Kurigram	Tollabag	Family	234543	Sublet	Non-Attached	Non-Attached	Test
Nijhum Sultana	+8801832328232	Rajshahi	Rangpur	Dhanmondi-27	Bachelor	234543	Flat	Attached	Attached	Test
Nijhum Sultana	+8801748402406	Barishal	Natore	Badda	Family	12356	Sublet	Attached	Attached	nothing
word press 5	+8801748402408	Barishal	Bogura	Tollabag	Bachelor	4622	Seat	Attached	Attached	tenant po

Showing 1 to 4 of 4 entries Previous 1 Next

Figure 6.18: Delete Necessity for Admin

6.19 Add Area Guide

127.0.0.1:8000/admin/area/index

✓ You Successfully added area guide

Area [Add New +](#)

Show 10 entries Search:

No	Area	Link	Action
1	test	KTa9c9mB2s4	
2	test	KTa9c9mB2s4	
3	Mirpur-2	rSMdGelwA5U	

Showing 1 to 3 of 3 entries [Previous](#) [1](#) [Next](#)

Copyright © Team Alpha 2021

Figure 6.19: Add Area Guide

6.20 View Area Guide for Admin

127.0.0.1:8000/admin/area/index

Mou

Area [Add New +](#)

Show 10 entries Search:

No	Area	Link	Action
1	test	KTa9c9mB2s4	
2	test	KTa9c9mB2s4	

Showing 1 to 2 of 2 entries [Previous](#) [1](#) [Next](#)

Copyright © Team Alpha 2021

Figure 6.20: View Area Guide for Admin

6.21 Delete Area guide

Area guide Deleted successfully

Area

Show 10 entries Search:

No	Area	Link	Action
1	test	KTagc9mB2s4	
2	Mirpur-2	rSMdGeJwA5U	

Showing 1 to 2 of 2 entries Previous 1 Next

Copyright © Team Alpha 2021

Figure 6.21: Delete Area guide

6.22 Manage About Us

About Us

Show 10 entries Search:

Title	Details	Image	Action
About Us	The "Digital To-Let System" is a web-based project that will help the general people for the sake of searching rented home/seat/sublet. As our country is a densely populated country that's why every moment there is a crisis of accommodation. My system will help a tenant to find his/her desired home or seat or sublet which is given by the Owner. If he/she wants to contact the Owner, he/she can easily get the information through the system. On the other hand, the system will not only solve the tenants' problem but also able to solve the owners' problem by getting information from tenants.	ABOUT	
About Us	Bangladesh is the most densely populated country in the world. Bangladesh ranks 11th in terms of population density. That's why its population faces an accommodation problem. Bangladesh is improving the Educational sector day by day. Even the Rural students have realized the value of education. They are moving to the city for the sake of satisfying their hunger for education. As all the students don't belong to a well-established family, so they want to complete their education with limited expenses. In our country, all industrial factories are situated in urban areas. That's why everyone from the lower class people to the upper-middle class is moving to the city. That's why there is a crisis for housing every year.	ABOUT	
About Us	Bangladesh is the most densely populated country in the world. Bangladesh ranks 11th in terms of population density. That's why its population faces an accommodation problem. Bangladesh is improving the Educational sector day by day. Even the Rural students have realized the value of education. They	ABOUT	

Mou

Figure 6.22: Manage About Us

6.23 Logout for Admin

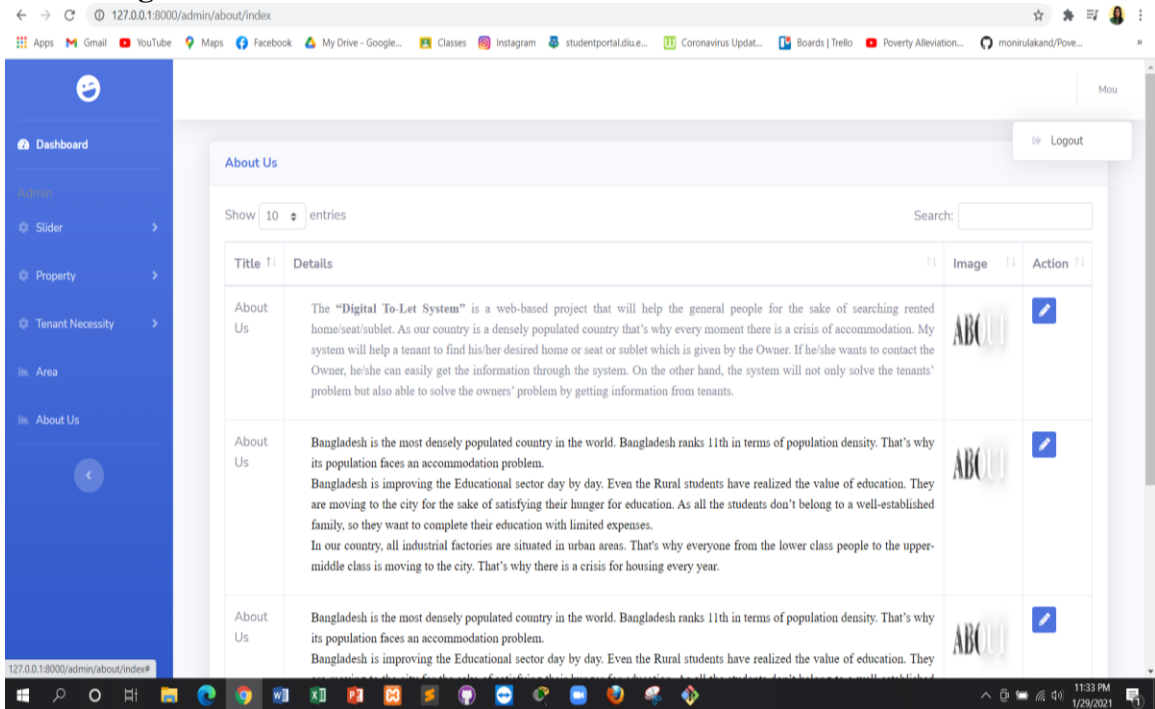

Figure 6.23: Logout for Admin

6.24 Owner Dashboard

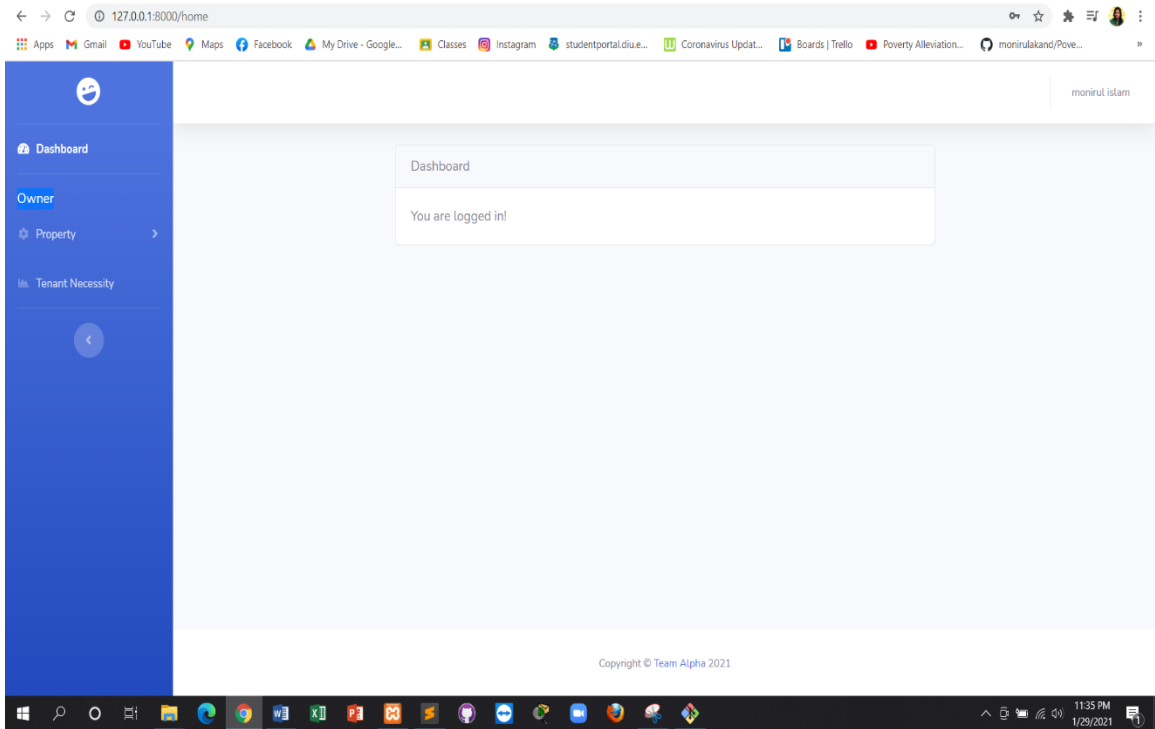

Figure 6 24: Owner Dashboard

6.25 Create Property Post for Owner

Property

Show 10 entries Search:

Owner Name	Modile No	Division	District	Location	Tenant Type	Lift	Rent	Room-Quantity	Washroom-Quantity	Balcony-Quantity
Nijhum Sultana	+8801748402406	Sylhet	Khulna	Tollabag	Bachelor	No	12345	1	1	2
word press 5	+8801747402406	Mymensingh	Bogura	Sobhanbag	Bachelor	No	12345	1	1	1

Showing 1 to 2 of 2 entries

Previous 1 Next

Copyright © Team Alpha 2021

Figure 6.25: Create Property Post for Owner

6.26 View Property Post for Owner

Property

Show 10 entries Search:

Owner Name	Modile No	Division	District	Location	Tenant Type	Lift	Rent	Room-Quantity	Washroom-Quantity	Balcony-Quantity
Nijhum Sultana	+8801748402406	Sylhet	Khulna	Tollabag	Bachelor	No	12345	1	1	2
word press 5	+8801747402406	Mymensingh	Bogura	Sobhanbag	Bachelor	No	12345	1	1	1

Showing 1 to 2 of 2 entries

Previous 1 Next

Copyright © Team Alpha 2021

Figure 6.26: View Property Post for Owner

6.27 Update Property Post for Owner

Property updated successfully

Property

Add New +

Search:

Division	District	Location	Tenant Type	Lift	Rent	Room-Quantity	Washroom-Quantity	Balcony-Quantity	Floor	Image	Comment
sylhet	Khulna	Tollabag	Bachelor	No	12345	1	1	2	5		tfvbutybuyinl
chittagong	Kurigram	Banani	Bachelor	yes	12345	1	1	1	2		jmhnhniuhni

Previous 1 Next

Copyright © Team Alpha 2021

Figure 6.27: Update Property Post for Owner

6.28 Delete Property Post for Owner

Property Deleted successfully

Property

Add New +

Show 10 entries

Search:

Owner Name	Modile No	Division	District	Location	Tenant Type	Lift	Rent	Room-Quantity	Washroom-Quantity	Balcony-Quantity	Floor
No data available in table											

Showing 0 to 0 of 0 entries

Previous Next

Copyright © Team Alpha 2021

Figure 6.28: Delete Property Post for Owner

6.29 View Necessity Post for Owner

The screenshot displays a web application interface for viewing tenant necessity posts. The main content area features a table with the following data:

Tenant Name	Phone	Division	District	Location	Tenant Type	Budget	Home	Washroom	Balcony	Comment
mou	2345324545	Khulna	Kurigram	Tollabag	Family	234543	Sublet	Non-Attached	Non-Attached	Test
Nadim Hasan	01745214586	Rajshahi	Kurigram	Badda	Bachelor	2244	Seat	Non-Attached	Non-Attached	nothing
Nijhum Sultana	+8801832328232	Rajshahi	Rangpur	Dhanmondi-27	Bachelor	234543	Flat	Attached	Attached	Test
word press 5	+8801748402408	Barishal	Bogura	Tollabag	Bachelor	4622	Seat	Attached	Attached	tenant po

The interface also includes a sidebar with navigation options (Dashboard, Owner, Property, Tenant Necessity), a top navigation bar with 'Logout' and 'Add New +' buttons, and a table control showing 'Showing 1 to 4 of 4 entries' with 'Previous' and 'Next' buttons.

Figure 6.29: View Necessity Post for Owner

6.30 Logout for Owner

The screenshot displays the same web application interface as Figure 6.29, showing the 'Tenant Necessity' table with the same data. The interface elements, including the sidebar, top navigation bar, and table control, are identical. The 'Logout' button in the top navigation bar is highlighted, indicating the user is about to log out.

Figure 6.30: Logout for Owner

6.31 Tenant Dashboard

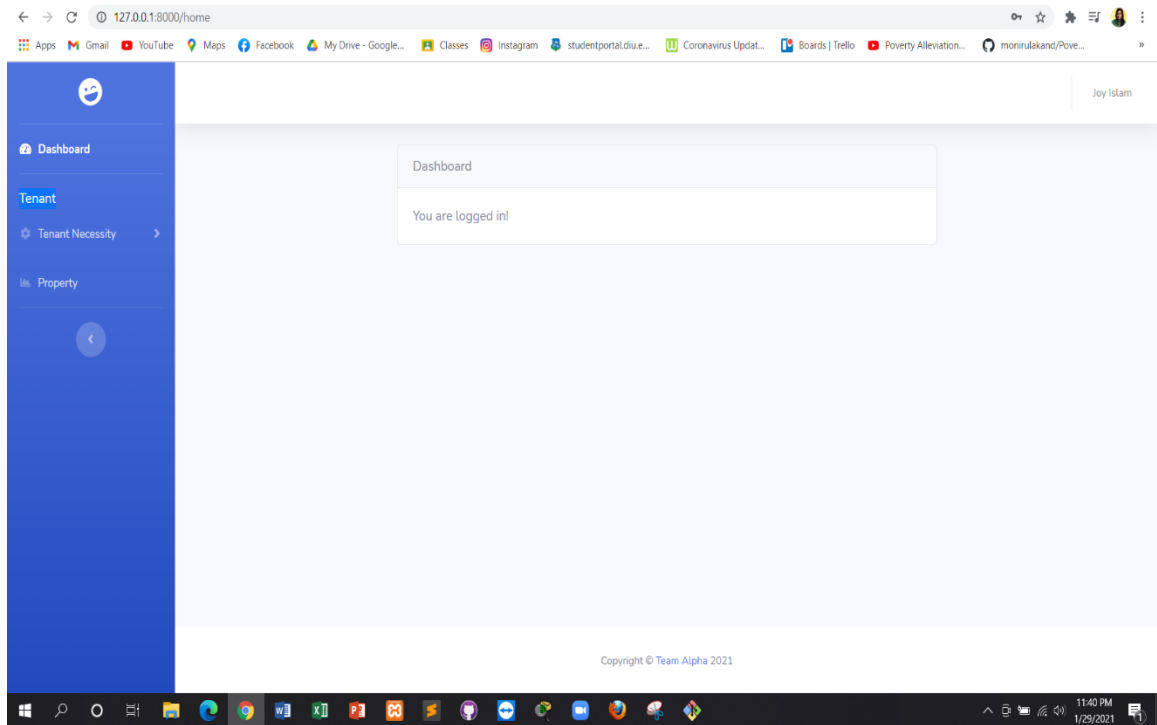

Figure 6.31: Tenant Dashboard

6.32 Create Necessity Post for Tenant

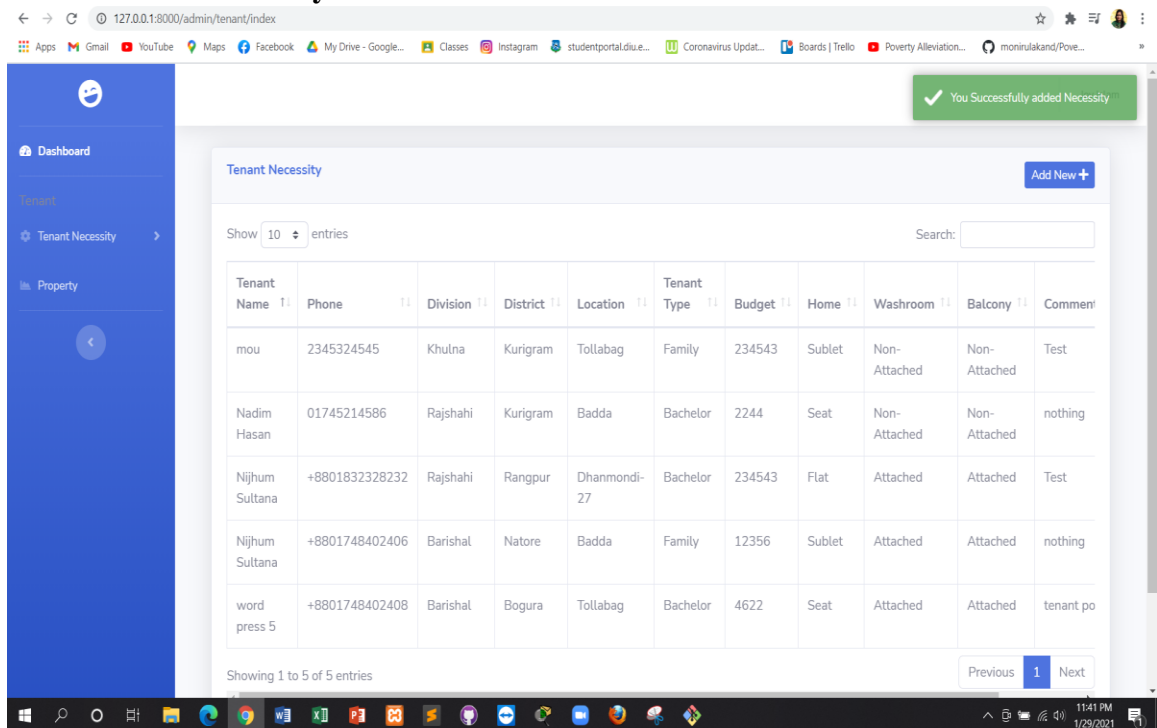

Figure 6.32: Create Necessity Post for Tenant

6.33 View Necessity Post for Tenant

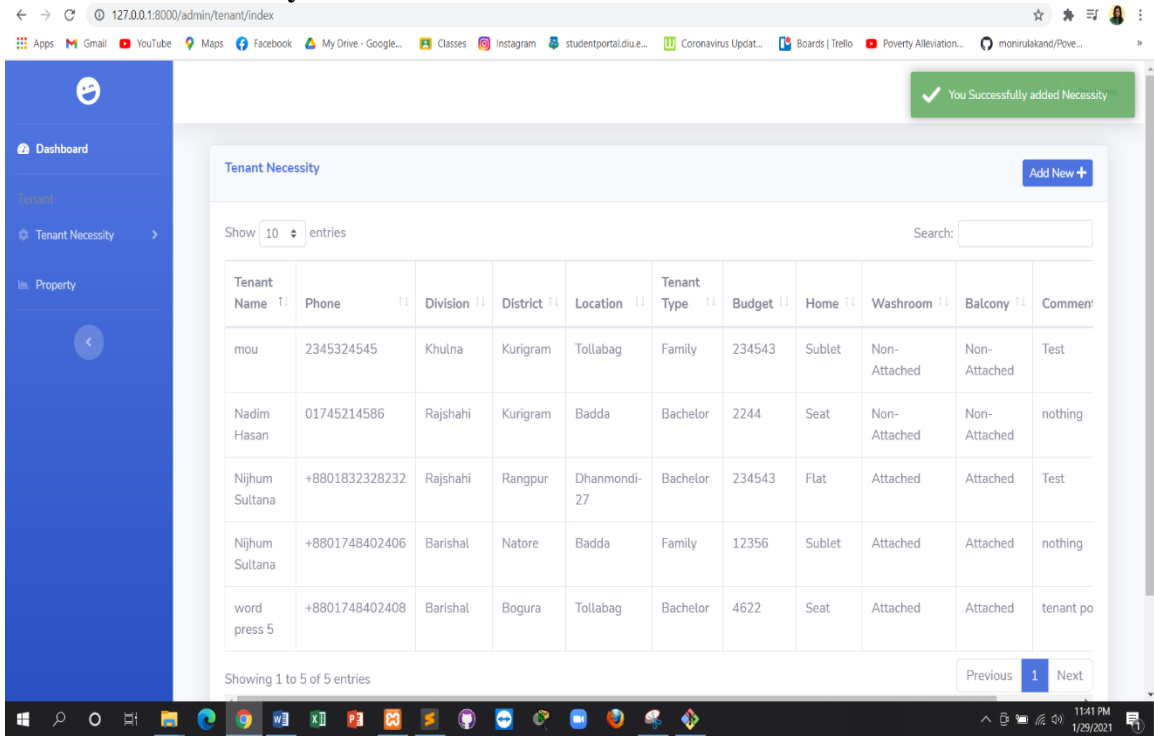

Figure 6.33: View Necessity Post for Tenant

6.34 Update Necessity Post for Tenant

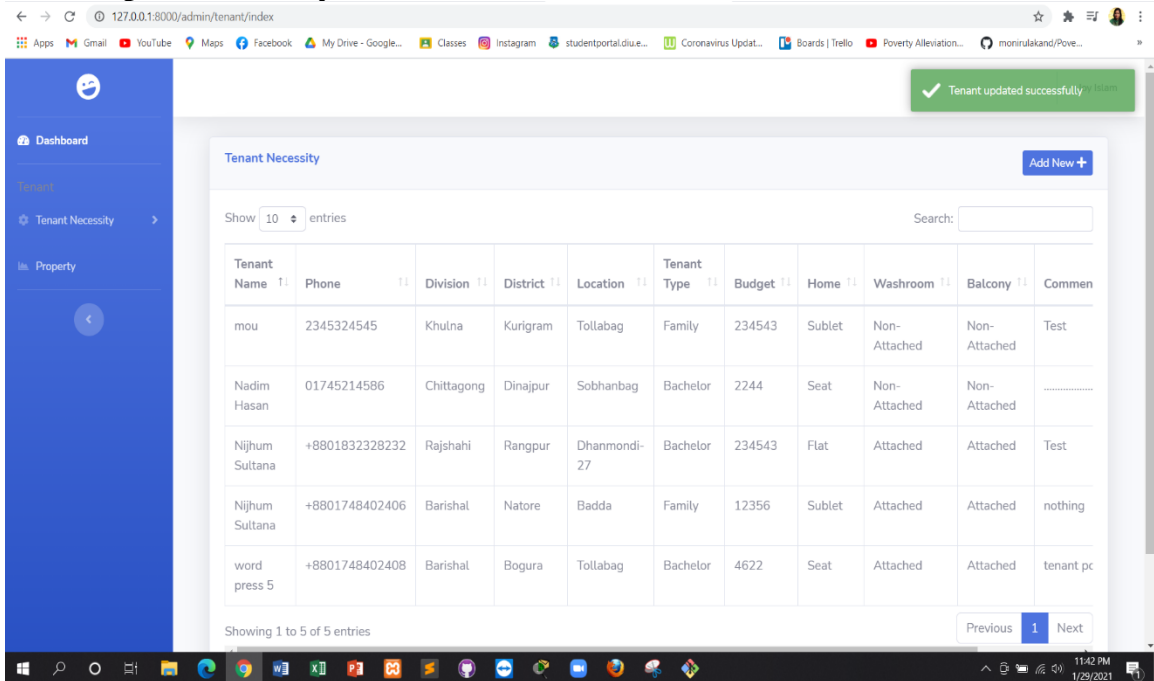

Figure 6.34: Update Necessity Post for Tenant

6.35 Delete Necessity Post for Tenant

Property Deleted successfully

Tenant Necessity

Show 10 entries Search:

Tenant Name	Phone	Division	District	Location	Tenant Type	Budget	Home	Washroom	Balcony	Comment
Nijhum Sultana	+8801832328232	Rajshahi	Rangpur	Dhanmondi-27	Bachelor	234543	Flat	Attached	Attached	Test
Nijhum Sultana	+8801748402406	Barishal	Natore	Badda	Family	12356	Sublet	Attached	Attached	nothing
word press 5	+8801748402408	Barishal	Bogura	Tollabag	Bachelor	4622	Seat	Attached	Attached	tenant post

Showing 1 to 3 of 3 entries

Previous 1 Next

Copyright © Team Alpha 2021

Figure 6.35: Delete Necessity Post for Tenant

6.36 View Property Post for Tenant

Joy Islam

Property

Show 10 entries Search:

Owner Name	Modile No	Division	District	Location	Tenant Type	Lift	Rent	Room-Quantity	Washroom-Quantity	Balcony-Quantity
Nijhum	+8801748402406	Rangpur	Kurigram	Mohammadpur	Bachelor	No	14569	1	1	1

Showing 1 to 1 of 1 entries

Previous 1 Next

Copyright © Team Alpha 2021

Figure 6.36: View Property Post for Tenant

6.37 Logout for Tenant

The screenshot displays a web application interface for managing properties. The browser address bar shows the URL `127.0.0.1:8000/admin/property/index`. The user is logged in as 'Joy Islam'. The main content area is titled 'Property' and features a table with the following data:

Owner Name	Modile No	Division	District	Location	Tenant Type	Lift	Rent	Room-Quantity	Washroom-Quantity	Balcony-Quantity
Nijhum	+8801748402406	Rangpur	Kurigram	Mohammadpur	Bachelor	No	14569	1	1	1

Below the table, it indicates 'Showing 1 to 1 of 1 entries' with 'Previous' and 'Next' navigation buttons. A 'Logout' button is located in the top right corner of the application area. The sidebar on the left contains navigation links for 'Dashboard', 'Tenant', 'Tenant Necessity', and 'Property'. The footer of the application area contains the text 'Copyright © Team Alpha 2021'. The Windows taskbar at the bottom shows the system time as 11:11 PM on 1/30/2021.

Figure 6.37: Logout for Tenant

CHAPTER 7

CONCLUSION

7.1 GitHub Link

<https://github.com/NijhumSultanaMou/Final-Project>

7.2 Project Summary

I have started to work on this project from December 2020. Actually, I built this project for public purpose. This site helps users a lot by reducing their time and cost. Public can get the facility of servicing system. They can find their accommodation easily staying at their home.

7.3 Limitation

I have tried my level best to make things better but some of the required features are not properly created.

- UI is not so good as it should.

7.4 Future Scope

- Notification for the registered user
- User profile update
- Admin approval

REFERENCES

W3Schools Online Web Tutorials. W3schools.com. Retrieved 29 January 2021, from

<https://www.w3schools.com/>.

Laravel Documentation - Laravel - The PHP Framework For Web Artisans. Laravel.com. Retrieved

29 January 2021, from <https://laravel.com/docs/8.x/readme>.

Property & Real Estate for sale and for rent in Bangladesh | bproperty.com. Bproperty.com.

Retrieved 29 January 2021, from <https://www.bproperty.com/>.

Stack Overflow - Where Developers Learn, Share, & Build Careers. Stack Overflow. Retrieved 30

January 2021, from <https://stackoverflow.com/>.

Retrieved 30 January 2021, from <https://www.youtube.com/watch?v=ImtZ5yENzgE>.

Retrieved 30 January 2021, from

<https://www.youtube.com/watch?v=zckH4xalOns&list=PL4cUxeGkcC9hL6aCFKyagrT1RCfVN4w2Q>.

Retrieved 30 January 2021, from

https://www.youtube.com/watch?v=t_2Gv5gx5Pk&list=PLxFwLONcxFJBjuZEHqaZrbbj83IRQkiz&ab_channel=PenguinDigital&fbclid=IwAR1f-auhcnYCKzjH_GUF-RJicDp9IGeuuRhG_n-x-rux752Oc8DUP2NFVs.

PLAGIARISM REPORT

2/1/2021

Turnitin

Turnitin Originality Report

Processed on: 01-Feb-2021 11:09 +06

ID: 1498793494

Word Count: 13826

Submitted: 1

171-35-1981 By Nijhum Sultana

Similarity Index

15%

Similarity by Source

Internet Sources: 14%

Publications: 1%

Student Papers: 7%

4% match (Internet from 01-Apr-2020)

<https://www.slideshare.net/RaihanMahmud5/rempte-doctor-project-report>

3% match (student papers from 30-Jul-2020)

[Submitted to Daffodil International University on 2020-07-30](#)

1% match (Internet from 09-May-2009)

<http://www.ismi.sematech.org/emanufacturing/docs/guidebook.pdf>

1% match (Internet from 10-Jan-2020)

<http://dspace.daffodilvarsity.edu.bd:8080/bitstream/handle/123456789/3551/P13655%2823%25%29.pdf?isAllowed=v&sequence=1>

1% match (Internet from 10-Nov-2020)

<http://dspace.daffodilvarsity.edu.bd:8080/bitstream/handle/123456789/3552/P13658%20%287%25%29.pdf?isAllowed=v&sequence=1>

1% match (Internet from 27-Aug-2020)

http://dspace.daffodilvarsity.edu.bd:8080/bitstream/handle/123456789/4173/P15398%20%2820_%29_.pdf?isAllowed=v&sequence=1

1% match (Internet from 15-Mar-2020)

<http://dspace.daffodilvarsity.edu.bd:8080/bitstream/handle/123456789/3553/P13659%20%2829%25%29.pdf?isAllowed=v&sequence=1>

< 1% match (Internet from 06-Jan-2020)

<http://dspace.daffodilvarsity.edu.bd:8080/bitstream/handle/123456789/3547/P13646%20%2824%25%29.pdf?isAllowed=v&sequence=1>

< 1% match (Internet from 14-May-2019)

<https://www.irjet.net/archives/V6/i3/IRJET-V6I3466.pdf>

< 1% match (Internet from 20-Dec-2019)

<http://dspace.daffodilvarsity.edu.bd:8080/bitstream/handle/123456789/3545/P13643%20%2816%25%29.pdf?isAllowed=v&sequence=1>

< 1% match (Internet from 02-Nov-2020)

<http://dspace.daffodilvarsity.edu.bd:8080/bitstream/handle/123456789/4609/162-10-402.pdf?isAllowed=v&sequence=1>

< 1% match (Internet from 07-Jan-2020)

<http://dspace.daffodilvarsity.edu.bd:8080/bitstream/handle/123456789/2198/P13011%20%28oid%29.docx?isAllowed=v&sequence=1>

< 1% match (Internet from 24-Sep-2015)

<http://www.theflud.com/www-myuhc-com-igin-united-health-care-to-get-health-plans/>

< 1% match (Internet from 16-May-2020)

<https://id.123dok.com/document/zog18zo-implemnetasi-algoritma-k-nearest-neighbor-untilk-mengklasifikasi-motif-batik-besurek-bengkulu.html>

https://www.turnitin.com/newreport_printview.asp?eq=1&eb=1&esm=10&oid=1498793494&sid=0&n=0&m=2&sv=48&r=64.14882544561343&langne... 1/19