

**INTERNSHIP ON INTERNET SERVICE PROVIDER (ISP)**

**BY**

**Name: Abu Saleh Md Noman**

**ID: 191-15-12897**

This Report Presented in Partial Fulfillment of the Requirements for the Degree of Bachelor of Science in Computer Science and Engineering.

Supervised By

**Name: Md. Sazzadur Ahamed**

Sr. Lecturer

Department of CSE

Daffodil International University

Co-Supervised By

**Ms. Nusrat Jahan**

Sr. Lecturer

Department of CSE

Daffodil International University



**DAFFODIL INTERNATIONAL UNIVERSITY**

**DHAKA, BANGLADESH**

**6<sup>TH</sup> JANUARY, 2022**

## **APPROVAL**

This Project/Internship titled “**INTERNSHIP ON ISP OPERATION**”, submitted by **Abu Saleh Md Noman, ID No 191-15-12897** to the Department of Computer Science and Engineering, Daffodil International University, has been accepted as satisfactory for the partial fulfillment of the requirements for the degree of B.Sc. in Computer Science and Engineering and approved as to its style and contents. The presentation has been held on **06/01/2022**

### **BOARD OF EXAMINERS**



**Chairman**

---

**Dr. S.M Aminul Haque**

**Associate Professor and Associate Head**

Department of Computer Science and Engineering

Faculty of Science & Information Technology

Daffodil International University

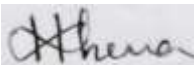

**Internal Examiner**

---

**Most. Hasna Hena (HH)**

**Assistant Professor**

Department of Computer Science and Engineering

Faculty of Science & Information Technology

Daffodil International University

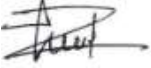

**Internal Examiner**

---

**Md. Jueal Mia (MJM)**

**Senior Lecturer**

Department of Computer Science and Engineering

Faculty of Science & Information Technology

Daffodil International University



**External Examiner**

---

**Dr. Md Arshad Ali**

**Associate Professor**

Department of Computer Science and Engineering

Hajee Mohammad Danesh Science and Technology  
University

## DECLARATION

We hereby declare that, this project has been done by us under the supervision of **Md. Sazzadur Ahamed, Sr. Lecturer, Department of CSE**, Daffodil International University. We likewise announce that neither this project nor any piece of this undertaking has been submitted somewhere else for grant of any degree or diploma.

### Supervised by:



---

**Md Sazzadur Ahamed**  
**Sr. Lecturer**  
Department of CSE  
Daffodil International University

### Co-Supervised by:

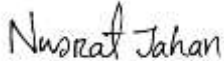

---

**Ms. Nusrat Jahan**  
**Sr. Lecturer**  
Department of CSE  
Daffodil International University

### Submitted by:



---

**Abu Saleh Md Noman**  
**ID: 191-15-12897**  
Department of CSE  
Daffodil International University  
©Daffodil International University

## ACKNOWLEDGEMENT

First I am express of heartiest thanks and gratefulness to almighty God for His divine blessing makes us possible to complete the final year project/internship successfully.

I'm really grateful and wish of my profound our indebtedness to **Md. Sazzadur Ahamed Sr. Lecturer**, Department of CSE Daffodil International University, Dhaka, deep Knowledge & keen interest of our supervisor in the field of ISP “Networking” to carry out this project. His endless patience ,scholarly guidance ,continual encouragement , constant and energetic supervision, constructive criticism , valuable advice ,reading many inferior draft and correcting them at all stage have made it possible to complete this project.

I would like to express of my heartiest gratitude to **Professor Dr. Touhid Bhuiyan**, Professor, Department of CSE and Head Department of CSE, for his caring assistance to complete our venture and furthermore to other employee and the staff of CSE department of Daffodil International University.

I would like to thank of my entire course mate in Daffodil International University, who took part in this discuss while completing the course work.

At last, we should recognize with due regard the steady help and patients of our folks.

## **ABSTRACT**

This internship represents on ISP Operation. The main reason and objective of the report is learning about Computer Networking, ISP Networking Device such as Server, Computer, Cable, Router and Switch connection by practical experience at Aamra Network Limited, Banani, Dhaka.

At Aamra Network Limited working with MIKROTIK, CISCO ,NETGEAR, WINDOWS SERVER and so on . Working with them I can gather a lot of knowledge about how the configure a network, how the troubleshoot a problem with a large network.

In my four-month internship time at Aamra Network Limited, I gain a lot of knowledge about working environment.

# CONTENTS

## TABLE OF CONTENTS

<b>CONTENTS</b>	<b>PAGE</b>
Approval:	i
Board of Examiners:	i-ii
Declaration:	iii
Acknowledgement:	iv
Abstract:	v
<b>CHAPTER 1: INTRODUCTION</b>	<b>1-3</b>
1.1 Introduction	1
1.2 Motivation	1-2
1.3 Internship Objectives	2
1.4 Introduction to Company	2
1.5 Report Layout	3
<b>CHAPTER 2: ORGANIZATION</b>	<b>4-5</b>
2.1 Introduction	4
2.2 Product and Market Situation	4
2.3 Organizational Structure	5
©Daffodil International University	vi

<b>CHAPTER 3: BASIC NETWORKING KNOWLEDGE</b>	<b>6-12</b>
3.1 Daily Task and Activities	6
3.2 First few days they teach me about basic knowledge	6
3.3 Node, End device	6
3.4 Network Topology	6-7
3.5 Categories of Network	8-10
3.6 Transmission Type	11-12
3.7 Ethernet Cabling	12
<b>CHAPTER 4: IP ADDRESS</b>	<b>13-33</b>
4.1 IP Address	13
4.2 IP Address Class	14
4.3 C –class subnet mask	14-16
4.4 A-class subnet mask	17-18
4.5 B Class subnet mask	19-21
4.6 Routing protocol	21
4.7 Administrative Distance	22
4.8. Routing Information protocol Basic	23-24
4.9 Rip v-2	24-26
4.10 EIRGP	27-29
4.11 Static Routing Configuration Guide	30-31
4.12 Default Routing	32-33



<b>CHAPTER 5: MIKROTIK</b>	<b>34-43</b>
5.1 Definition of MikroTik Router	34
5.2 Router Setup Steps	34
5.3 Mikrotik Router Features	34-35
5.4 MikroTik Router Interface	35
5.5 Bridge Interface	36
5.6 Concept of Bandwidth Control	37
5.7 Configuration	37-38
5.8 DHCP Server on MikroTik Router Basic	39-41
5.8.1 DHCP Server	39
5.8.2 DHCP Server Configuration	40-41
5.9 NAT	41
5.9.1 Working Procedure of NAT	42
(ISP) Network Diagram	43
<b>CHAPTER 6: CONCLUSION</b>	<b>44</b>
Future outcome	45
<b>Appendixes</b>	<b>46</b>
<b>References</b>	<b>47</b>

# LIST OF FIGURES

<b>FIGURES</b>	<b>Page</b>
Figure 3.1: Local Area Network	8
Figure 3.2: Metropolitan Area Network	9
Figure 3.3: World Area Network	10
Figure 3.4: Unicast	11
Figure 3.5: Multicast	11
Figure 3.6: Broadcast	11
Figure 3.7: RJ 45 Connector	12
Figure 3.8: CAT 5 UTP	12
Figure 4.1: IP Related Figure	22
Figure 4.2 RIP V-1	23
Figure 4.3: RIP V-2	25
Figure 4.4: EIGRP	28
Figure 4.5: Static Routing	30
Figure 4.6: Default Routing	32
Figure 5.1: Mikrotik interface	35
Figure 5.2: Bridge Interface	36
Figure 5.3: B/w control	38
Figure 5.4: DHCP Server Configuration	39
Figure 5.5: DHCP Server Configuration	40
Figure 5.6: IP Address Assigned	41
Figure 5.7.: NAT Routing	41
Figure 5.8: NAT Configure	42

<b>Table</b>	<b>Page</b>
Table: 4.1 Subnet Mask Class A/12	17
Table: 4.2 Subnet Mask Class A/13	18
Table: 4.3 Subnet Mask Class B /19	19
Table: 4.4 Subnet Mask Class B/21	20
Table: 4.5 Subnet Mask Class B /17	21

# CHAPTER 1

## Introduction of Networking

### 1.1 Introduction

Internship is one kind of opportunity for express someone's perfect talent. We need to store some of useful information for our each and every if the education is not over yet. The internship is for those student who are self-sufficient and successful with the opportunity to be validated by teachers and supervisors for the best future. In each case, they have achieved it despite obstacles that we cannot imagine perfectly. That is also most important matter to choose one firm or institute for Internship, which is better than the other companies. So we can learn a lot from a good organization. As a student of Computer Science and Engineering I joined the “Aamra Network Limited” to finish of my BSc in CSE and nurtured her desire to learn as much as I could. The point to which you read the book is not very different but this is much of difficult to understood from the book how the ISP organization and network is run. The languages of books are not honestly easy, but the language of internal composition. Basically it is taught about network, configuration, server and so on related to this things. That is also learning how people work and work overnight to support the network & also support network provide. Helps to learn things after being involved. This experience helps you do things after being involved in a task. Global experience and achievement. I found networking, communication, find problem and try to solve this, configuration and site research also, server management and others that I could not learn through the textbook. Ideal for my future work in network services with a network administrator.

### 1.2 Motivation

A computer network is a process of computer systems and attaches with other computer hardware. A communication network that allows a computer to transfer data one device to another devices. That is founded connection two or many more than two device. That is can connect via wire or wireless connection between each and other devices. If we can connect our device physically, that doesn't mean we are done yet. For setup a network which transfer data, we need to set the protocol, how data can be transmit each moment via cable or wireless network system. Now a day's internet is the most popular for communication system. Network can connect globally in one network.

We know that Internet can connect very easily one country to another country all over the world through by powerful internet system. Internet as like as easy but it's too risky if we don't have any kinds of idea about how to secure and use network. Most of the problem with the internet is Hacker. Sometime Hacker can hack our computer or any device via internet .For this reason we need to make a strong security system for banking and office network. Office network setup system is very important nowadays, because of all kinds of office (Public or Private) all of them using internet and other networking device for their communication and maintaining the office work.

### **1.3 Internship Objectives:**

The goal of my internship is achieving good work experience on this field or branch .I can use it of my future career.

But the main goal of the internship is fulfilling of the requirement complete of BSc in CSE program.

There are having some other goal is-

- Gather knowledge about ISP Networking System
- Achieving knowledge about Router and Server configuration, Routing about ISP
- Establishing connection of entire network of organization
- Configuring network of entire network of organization.

### **1.4 Introduction to The company**

If I want to complete my BSc, I need to fulfill its requirement finishes. And internship of an organization is the requirement for completing my BSc. So I can choose Aamra Network Limited, for completing my internship. Because it's the one of most popular and best Internet Provider. They are provide TR 1 and TR 2 types of service. Bangladesh Government, BCB and BFF got internet service from them .There are having multiple branches all over the country .They are independent company. And the most important thing is they teach first then they give the opportunity to internship in their company.

## **1.5 Report Layout**

At the first chapter of this report its discuss about introduction of my internship and briefly discuss about of my motivation. In second chapter that is briefly discuss about my internship 's organization. It's told about role of my organization, product and market place, target group, SWOT analysis, organization structure. In chapter three its briefly discussed about my daily task and what I learn from my internship session. In chapter four discussed about similarly which is I learned from institute and that is continue up to before the last chapter. In the last chapter discuss about the conclusion and about my future life on this area.

## **CHAPTER 2**

### **ORGANIZATION**

#### **2.1 Introduction**

I want to join Internet Service Provider company which is serve internet, mail service, cloud storage service, server configuration network troubleshoots for reputed client. It will be good for me for future carrier. When I will get resource about ISP provider company, it will be very easier for me. When any task assign for me, I will be able to finish task easily due to my previous internship training. I am try to join Aamra Network Limited for internship. Then, I discussed with them. I try to research about them and I found its nationwide ISP in the country. This company have much of brunch all over the countries. Its headquarter 20 Kemal Ataturk Avenue, Banani C/A, Dhaka, Bangladesh.

#### **2.2 Product and Market Situation**

In internship program I have worked with Cisco, Mikrotik Router, DHCP and DNS Server, configuration AP Configuration Cloud and standalone mode Network and so on.

Especially I have learned about Cisco routing and switching. That is use for Corporate office & Garments, textile, multinational company, university hotel, for network configuration. Product of cisco range are switch, router, Security fabric, wireless system, storage networking and cloud computing service.

We know that network field job market is very large in the world. All multinational, company corporate office, 5-star hotel, Garments, university of any kind of organization need their own network. In this marketplace I have some good opportunities to make my future career.

## 2.3 Organizational Structure

Aamra networks organizational structure are given below.

- Chairman
- Managing Director
  - COO
  - General Manager
  - Deputy General Manager
  - Assistant General Manager
  - Senior Manager
  - Manager
  - Assistant Manager
  - Senior Engineer
  - Engineer
  - Junior Engineer



## **CHAPTER 3**

### **BASIC NETWORKING KNOWLEDGE**

#### **3.1 Daily Work and Performances**

As a intern I have a lot of work and performance every day. I have stored knowledge from my Internship Company which name is Aamra Network Limited. Every day I discuss with my team, they tech me all the term.

#### **3.2 First few days they teach me about basic knowledge**

1. Node, End device
2. Categories of Network
3. Network Topology
4. Types of transmission
5. Ethernet Cabling

#### **3.3 Node, End device**

Laptop Computer, Desktop Computer, Mobile Phone ,Scanner and any kinds of related device which is capable to send and receive data.

#### **3.4 Network Topology**

That is element of the communication network.

Types of Network Topology:

a. Mesh

b. Star

c. Bus

d. Ring and

e. Hybrid Topology

**a. Mesh Topology:** Dedicated point to point link to each several nodes. In this network with  $n$  nodes has  $n(n-1)/2$  ports

**b. Star Topology:** Star network most usual network. Star network configuration, each with main network device, as like as a switch, computer, hub and so on. Main network device working as like as a server.

**c. Bus Topology:** Each and every node are connect with a large cable .We know that it is called Bus topology.

**d. Ring Topology:** Ring topology is connected with point to point (P to P) link with each side only two nodes.

**e. Hybrid Network:** Hybrid network is combine multiple topology. That is sharing the advantage of various topology

### 3.5 Categories of Network

- a. Local Area Network (LAN)
- b. Metropolitan Area Network (MAN)
- c. Wide Area Network (WAN)

#### Local Area Network (LAN):

- a. Generally that is particular and owned.
- b. LAN Structure use for Residence, School ,College, Home and so on.
- c. There are using Ring, Bus and Star Topologies.

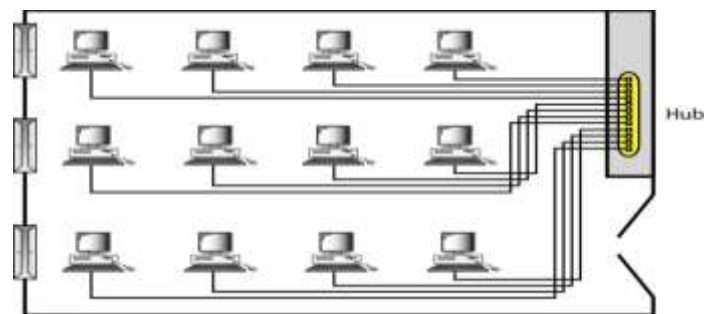

Figure 3.1: LAN

## Metropolitan Area network (MAN):

- a. That is design for whole city.
- b. ISP Provider and TV Cable Network,
- c. It is can be owned by a private or a public.

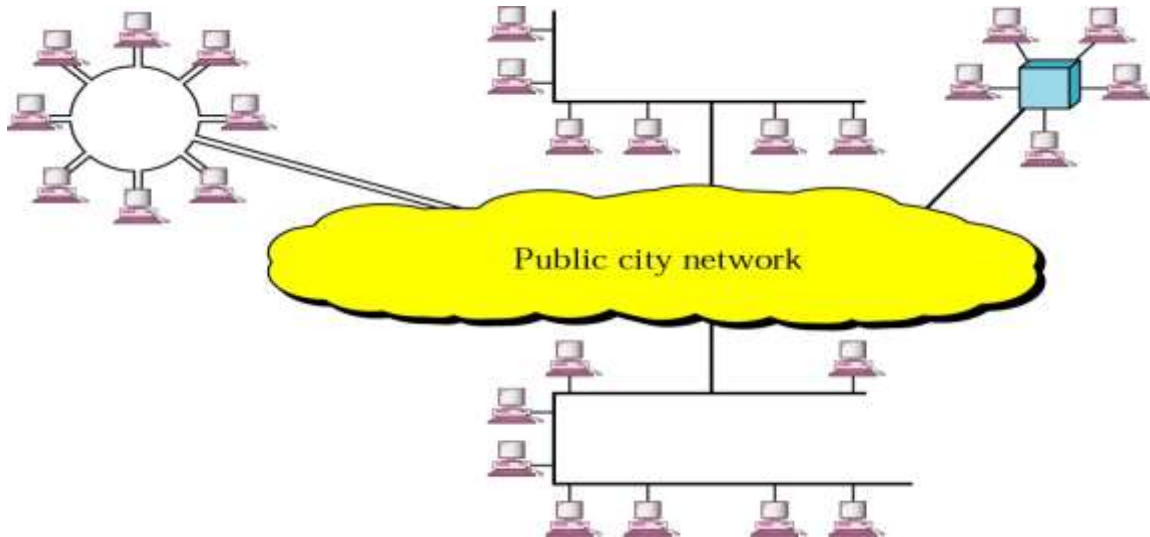

Figure3.2: Metropolitan Area Network

## Wide Area Network:

- a. Use for long distance transmission.
- b. WAN owned and used by one company.

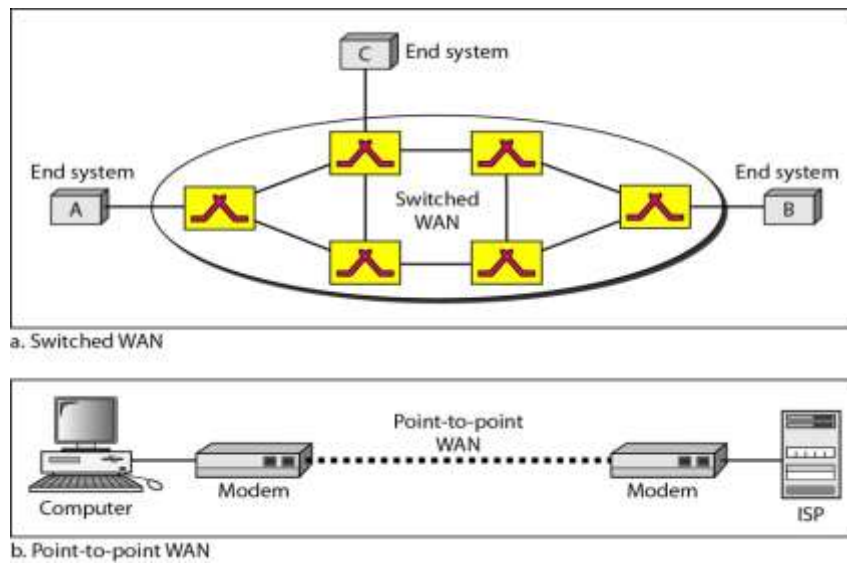

Figure 3.3: Wide Area Network

### 3.6 Transmission Type:

- a. Unicast
- b. Multicast
- c. Broadcast

**Unicast:** There are One sender and one receiver over the full network.

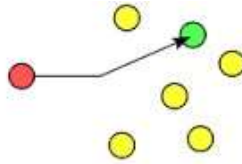

Figure 3.4: Unicast

**Multicast:** Multicast is communication one sender to some specific receiver over the full network.

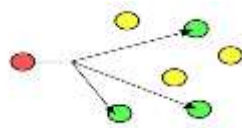

Figure 3.5: multicast

**Broadcast:** Broadcast is commonly used for one sender to all receiver over entire the network.

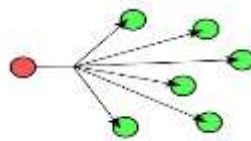

Figure 3.6: broadcast

## Connector:

There are using Ethernet Cabling. We can use here RJ 45 Connector .

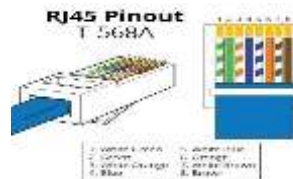

Fig 3.7: RJ-45 connector

## 3.7 Ethernet Cabling:

1. Straight Through
2. Crossover
3. Rolled Wire

When I build a network with Ethernet cabling, in this time I need to take an Ethernet cable. Which is used nowadays, the “Cat 5 Extended UTP”.



Fig 3.8: Category 5 Enhanced UTP

## Chapter 4

### CISCO

#### 4.1 IP Address

'IP' stands for 'Internet Protocol'. There are having two versions of IP that now coexist in the universal Internet (IPv4) and (IPv6). It is addresses are made up of binary and it is drive to the routing of all data over the Internet. IPv4 addresses are 32 bits long on the other hand IPv6 addresses are 128 bits long.

Both of them Still there will be a transition from IPv4 to IPv6. Although these two protocols cannot interact with each other directly, "dual stack" systems provide advantages for barter data between IPv4 and IPv6. Most important things is TCP/IP on the IP Addressing. That is written in dotted decimal form. 4 Octet are divided by dots (192.168.10.1). All octet carries a number between 0 to 255.

Internet Protocol are mandatory for internet communication. That maintain international protocol for Internet.[1]



## 4.2 IP address classes

<b>Class</b>	<b>Address range</b>
Class A	1.0.0.1 to 126.255.255.254
Class B	128.1.0.1 to 191.255.255.254
Class C	192.0.1.1 to 223.255.254.254
Class D	224.0.0.0 to 239.255.255.255

## 4.3 IP Subnet Class C

192.168.1.1/28

Block Size =240-256=16 Block size

$2^n=2^4=16$  Network

Host

$2^n - 2$

$2^4 - 2 = 16 - 2 = 14$

Subnet Mask: 255.255.255.240

Network	Host	B/A
192.168.1.0	1-14	15
192.168.1.16	17-30	31
192.168.1.32	33-46	47
192.168.1.48	49-62	63
192.168.1.64	65-78	79
192.168.1.80	81-94	95
192.168.1.96	97-110	111

192.168.1.112	113-126	127
192.168.1.128	129-142	14
192.168.1.144	145-158	159
192.168.1.160	161-174	175
192.168.1.176	177-190	191
192.168.1.192	193-206	207
192.168.1.208	209-222	223
192.168.1.224	225-238	239
192.168.1.240	241-254	255

192.168.1.1/29

Block Size = 248 – 256 = 8

$2^n = 2^5 = 32$  Network

Host

$2^n - 2$

$2^3 - 2 = 8 - 2 = 6$

Subnet Mask : 255 . 255 . 255 . 248

192 . 168 . 1 . 0/29

Subnet Mask: 255 . 255 . 255 . 248

$2 = 2^5 = 32$

$2^3 - 2 = 8 - 2 = 6$  Host

Block Size = 256 - 248 = 8

Network	Host	B/A
192.168.1.0	1-6	7
192.168.1.8	9-14	15
192.168.1.16	17-22	23
192.168.1.24	25-30	31

192.168.1.32	33-38	39
192.168.1.40	41-46	47
192.168.1.48	49-54	55
192.168.1.56	57-62	63
192.168.1.64	65-70	71
192.168.1.72	73-78	79
192.168.1.80	81-86	87
192.168.1.88	89-94	95
192.168.1.96	97-102	103
192.168.1.104	105-110	111
192.168.1.112	113-118	119
192.168.1.120	121-126	127
192.168.1.248	249-254	255

#### 4.4 A-Class Subnet Mask

10.0.0.0/12

Subnet Mask = 255.240.0.0

Block Size= 256-240=16

$2^n=2^4=16$  Network

$2^{20}-2=1048576-2=1048574$  Host

Table: 4.1 Subnet Mask Class A /12

Network	Host	B/A
10.0.0.0	10.0.0.1-10.15.255.254	10.15.255.255
10.16.0.0	10.16.0.1-10.31.255.254	10.31.255.255
10.32.0.0	10.32.0.1-10.47.255.254	10.47.255.255
10.48.0.0	10.48.0.1-10.63.255.254	10.63.255.255
10.64.0.0	10.64.0.1-10.79.255.254	10.79.255.255
10.80.0.0	10.80.0.1-10.95.255.254	10.95.255.255
10.96.0.0	10.96.0.1-10.111.255.254	10.111.255.255
10.112.0.0	10.112.0.1-10.127.255.254	10.127.255.255
10.128.0.0	10.128.0.1-10.143.255.254	10.143.255.255
10.144.0.0	10.144.0.1-10.159.255.254	10.159.255.255
10.160.0.0	10.160.0.1-10.175.255.254	10.175.255.255
10.176.0.0	10.176.0.1-10.191.255.254	10.191.255.255
10.192.0.0	10.192.0.1-10.207.255.254	10.207.255.255
10.208.0.0	10.208.0.1-10.223.255.254	10.223.255.255
10.224.0.0	10.224.0.1-10.239.255.254	10.239.255.255
10.240.0.0	10.240.0.1-10.255.255.254	10.255.255.255

10.0.0.0/13

Subnet Mask = 255.240.0.0

Block Size= 256-248=8

$2^n=2^5=32$  Network

$2^{19}-2=524288-2=524286$  Host

Table: 4.2 Subnet Mask Class A /13

Network	Host	B/A
10.0.0.0	10.0.0.1-10.7.255.254	10.7.255.255
10.8.0.0	10.8.0.1-10.15.255.254	10.15.255.255
10.16.0.0	10.16.0.1-10.23.255.254	10.23.255.255
10.24.0.0	10.24.0.1-10.31.255.254	10.31.255.255
10.32.0.0	10.32.0.1-10.39.255.254	10.39.255.255
10.40.0.0	10.40.0.1-10.47.255.254	10.47.255.255
10.48.0.0	10.48.0.1-10.55.255.254	10.55.255.255
10.56.0.0	10.56.0.1-10.63.255.254	10.63.255.255
10.64.0.0	10.64.0.1-10.71.255.254	10.71.255.255
10.72.0.0	10.72.0.1-10.79.255.254	10.79.255.255
10.80.0.0	10.80.0.1-10.87.255.254	10.87.255.255
10.88.0.0	10.88.0.1-10.95.255.254	10.95.255.255
10.96.0.0	10.96.0.1-10.103.255.254	10.103.255.255
10.104.0.0	10.104.0.1-10.111.255.254	10.111.255.255
10.112.0.0	10.112.0.1-10.119.255.254	10.119.255.255
10.120.0.0	10.120.0.1-10.127.255.254	10.127.255.255
10.128.0.0	10.128.0.1-10.135.255.254	10.135.255.255
10.136.0.0	10.136.0.1-10.143.255.254	10.143.255.255
10.144.0.0	10.144.0.1-10.151.255.254	10.151.255.255
10.152.0.0	10.152.0.1-10.159.255.254	10.159.255.255
10.160.0.0	10.160.0.1-10.167.255.254	10.167.255.255
10.168.0.0	10.176.0.1-10.175.255.254	10.175.255.255

10.176.0.0	10.176.0.1-10.183.255.254	10.183.255.255
10.184.0.0	10.184.0.1-10.191.255.254	10.191.255.255
10.192.0.0	10.192.0.1-10.199.255.254	10.199.255.255
10.200.0.0	10.200.0.1-10.207.255.254	10.207.255.255
10.208.0.0	10.208.0.1-10.215.255.254	10.215.255.255
10.216.0.0	10.216.0.1-10.223.255.254	10.223.255.255
10.224.0.0	10.224.0.1-10.231.255.254	10.199.255.255
10.232.0.0	10.232.0.1-10.239.255.254	10.1239.255.255
10.240.0.0	10.240.0.1-10.247.255.254	10.247.255.255
10.248.0.0	10.248.0.1-10.255.255.254	10.255.255.255

[2]

## 4.5 Sub-networking mask, B-class

### 172.16.0.0/19

Subnet Mask = 255.255.224.0

Block Size= 256-224=32

$2^n=2^3=8$  Network

$2^{13}-2=8192-2=8190$  Host[2]

Table: 4.3 Subnet Mask Class B /19

<b>Network</b>	<b>Host</b>	<b>B/A</b>
172.16.0.0	172.16.0.1-172.16.31.254	172.16.31.255
172.16.32.0	172.16.32.1-172.16.63.254	172.16.63.255
172.16.64.0	172.16.64.1-172.16.95.254	172.16.95.255
172.16.96.0	172.16.96.1-172.16.127.254	172.16.127.255
172.16.128.0	172.16.128.1-172.16.159.254	172.16.159.255
172.16.160.0	172.16.160.1-172.16.191.254	172.16.191.255
172.16.192.0	172.16.192.1-172.16.223.254	172.16.223.255
172.16.224.0	172.16.224.1-172.16.255.254	172.16.255.255

## 172.16.0.0/21

Subnet Mask = 255.255.248.0

Block Size= 256-248=8

$2^n=2^5=32$  Network

$2^{11}-2=2048-2=2046$  Host[2]

Table: 4.4 Subnet Mask Class A /21

<b>Network</b>	<b>Host</b>	<b>B/A</b>
172.16.0.0	<b>172.16.0.1-172.16.7.254</b>	172.16.7.255
172.16.8.0	<b>172.16.8.1-172.16.15.254</b>	172.16.15.255
172.16.16.0	<b>172.16.16.1-172.16.23.254</b>	172.16.23.255
172.16.24.0	<b>172.16.24.1- 172.16.31.254</b>	172.16.31.255
172.16.32.0	<b>172.16.32.1-172.16.39.254</b>	172.16.39.254
172.16.40.0	<b>172.16.40.1-172.16.47.254</b>	172.16.47.255
172.16.48.0	<b>172.16.48.1-172.16.55.254</b>	172.16.55.255
172.16.56.0	<b>172.16.56.1-172.16.63.254</b>	172.16.63.255
172.16.64.0	<b>172.16.64.1-172.16.71.254</b>	172.16.71.255
172.16.72.0	<b>172.16.72.1-172.16.79.254</b>	172.16.79.255
172.16.80.0	<b>172.16.80.1-172.16.87.254</b>	172.16.87.255
172.16.88.0	<b>172.16.88.1-172.16.95.254</b>	172.16.95.255
172.16.96.0	<b>172.16.96.1-172.16.103.254</b>	172.16.103.255
172.16.104.0	<b>172.16.104.1-172.16.111.254</b>	172.16.111.255
172.16.112.0	<b>172.16.112.1-172.16.119.254</b>	172.16.119.255
172.16.120.0	<b>172.16.120.1-172.16.127.254</b>	172.16.127.255
172.16.128.0	<b>172.16.128.1-172.16.135.254</b>	172.16.135.255
172.16.136.0	<b>172.16.136.1-172.16.143.254</b>	172.16.143.255
172.16.144.0	<b>172.16.144.1-172.16.151.254</b>	172.16.151.255
172.16.152.0	<b>172.16.152.1-172.16.159.254</b>	172.16.159.255
172.16.160.0	<b>172.16.160.1-172.16.167.254</b>	172.16.167.255
172.16.168.0	<b>172.16.168.1-172.16.175.254</b>	172.16.175.255
172.16.176.0	<b>172.16.176.1-172.16.183.254</b>	172.16.183.255

172.16.184.0	<b>172.16.184.1-172.16.191.254</b>	172.16.191.255
172.16.192.0	<b>172.16.192.1-172.16.199.254</b>	172.16.199.255
172.16.200.0	<b>172.16.200.1-172.16.207.254</b>	172.16.207.255
172.16.208.0	<b>172.16.208.1-172.16.215.254</b>	172.16.215.255
172.16.216.0	<b>172.16.216.1-172.16.223.254</b>	172.16.223.255
172.16.224.0	<b>172.16.224.1-172.16.231.254</b>	172.16.231.255
172.16.232.0	<b>172.16.232.1-172.16.239.254</b>	172.16.239.255
172.16.240.0	<b>172.16.240.1-172.16.247.254</b>	172.16.247.255
172.16.248.0	<b>172.16.248.1-172.16.255.254</b>	172.16.255.255

## 172.16.0.0/17

Subnet Mask = 255.255.128.0

Block Size= 256-128=128

$2^1=2^1=2$  Network

$2^{15}-2=32768-2=32766$  Host

Table: 4.5 Subnet Mask Class B /17

<b>Network</b>	<b>Host</b>	<b>B/A</b>
172.16.0.0	<b>172.16.0.1-172.16.0127.254</b>	172.16.127.255
172.16.128.0	<b>172.16.128.1-172.16.255.254</b>	172.16.255.255

[2]

## 4.6 Routing Protocol

1. Distance vector routing protocol Used bellman ford algorithm RIP V-1
2. Link state OSPF, IS-IS
3. Hybrid EIGP RIP V-2

### Link state Routing Protocol

A, Neighbor Table

B. Topology Table Neighbor information

C. Routing SPF



## 4.7 Administrative Distance

Connected	0
Static	0/1
EIGRP	90
EIGRP	100
OSPF	110
RIP	120
EIGRP EX	170



Figure 4.1 : IP Related

## 4.8 Routing Information Protocol Basic

1. Distance vector routing protocol
2. Bellman ford Algorithm
3. Local Broadcast to share routing information
4. Class full routing protocol
5. Broadcast update 30 sec
6. Hold down Timer 180 Sec
7. Flash Timer 240 sec
8. Uses Hop count as Metric
9. Maximum hop count 15
10. Four equal cost load Balance.[3]

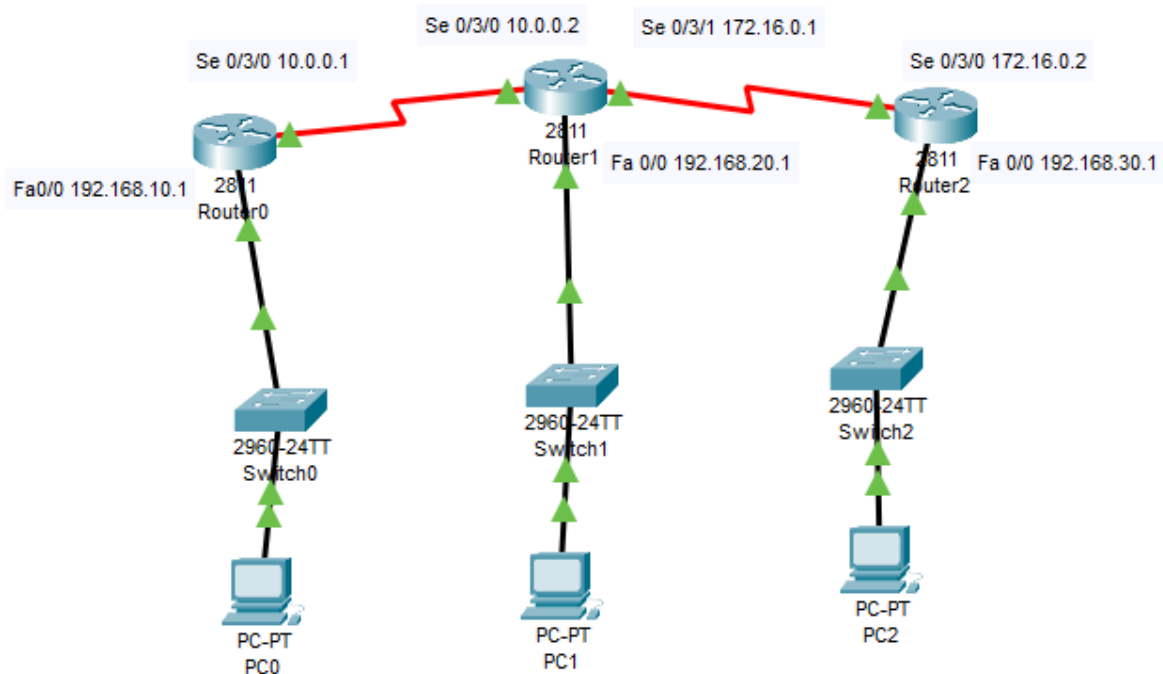

Figure 4.2: RIP V-1

## **RIP Version-1 Configuration Output**

```
router1#show ip route
```

Gateway of last resort is not set

C 10.0.0.0/8 is directly connected, Serial0/3/0

R 172.16.0.0/16 [120/1] via 10.0.0.2, 00:00:14, Serial0/3/0

C 192.168.10.0/24 is directly connected, FastEthernet0/0

R 192.168.20.0/24 [120/1] via 10.0.0.2, 00:00:14, Serial0/3/0

R 192.168.30.0/24 [120/2] via 10.0.0.2, 00:00:14, Serial0/3/0

```
router2#show ip route
```

Gateway of last resort is not set

C 10.0.0.0/8 is directly connected, Serial0/3/0

C 172.16.0.0/16 is directly connected, Serial0/3/1

R 192.168.10.0/24 [120/1] via 10.0.0.1, 00:00:15, Serial0/3/0

C 192.168.20.0/24 is directly connected, FastEthernet0/0

R 192.168.30.0/24 [120/1] via 172.16.0.2, 00:00:01, Serial0/3/1[3]

## **4.9 RIP V-2**

1. Hybrid routing Protocol
2. Based on rip V1
3. Multicasts to disseminate routing information 224.0.0.9
4. Supports triggered update.
5. Supports VLSM
6. Others are same to rip V1[3]

## 4.9.1 Rip V2 Configure

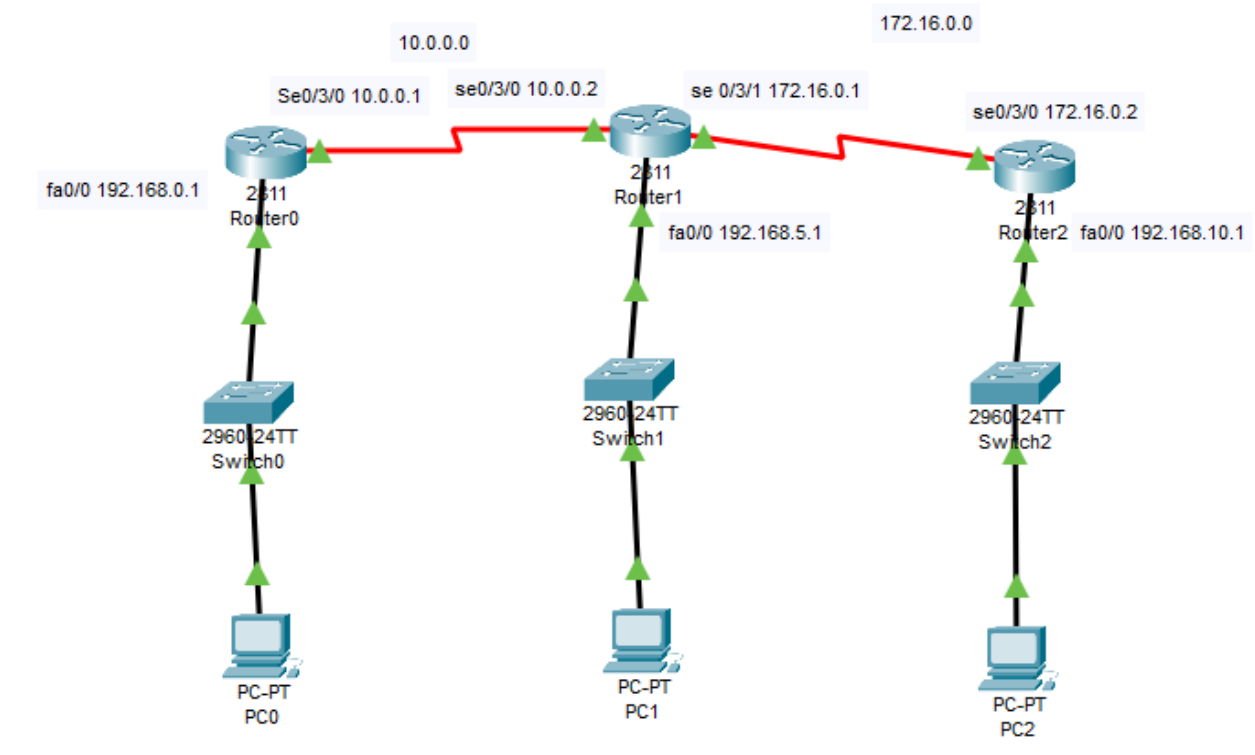

Figure: 4.3 RIP V-2

[3]

## RIP V2 Configuration Output

[OK]

Router#show ip route

Codes: C - connected, S - static, I - IGRP, R - RIP, M - mobile, B - BGP

Gateway of last resort is not set

C 10.0.0.0/8 is directly connected, Serial0/3/0

C 172.16.0.0/16 is directly connected, Serial0/3/1

R 192.168.0.0/24 [120/1] via 10.0.0.1, 00:00:17, Serial0/3/0

C 192.168.5.0/24 is directly connected, FastEthernet0/0

R 192.168.10.0/24 [120/1] via 172.16.0.2, 00:00:00, Serial0/3/1

Router# show ip route

Gateway of last resort is not set

R 10.0.0.0/8 [120/1] via 172.16.0.1, 00:00:24, Serial0/3/0

C 172.16.0.0/16 is directly connected, Serial0/3/0

R 192.168.0.0/24 [120/2] via 172.16.0.1, 00:00:24, Serial0/3/0

R 192.168.5.0/24 [120/1] via 172.16.0.1, 00:00:24, Serial0/3/0

C 192.168.10.0/24 is directly connected, FastEthernet0/0[3]

## 4.10 EIGRP

1. Enhanced interior gateway routing protocol
2. Based on EIGRP
3. Cisco proprietary
4. Hybrid routing protocol
5. Fast convergence
6. Support VLSM
7. Support IP, AppleTalk
8. Communication among the EIGRP routers are handed by RTP reliable transport protocol.
9. EIGRP is the best path are selected using dual (Diffusing update algorithm.
10. That is loop free topology
11. Manually and automatic route summarization by default auto summarization
12. Here is metric used bandwidth, delay ,load and reliability MTU .
13. Multicast and incremental update multicast address.

### 4.10.1 Three table are maintained by EIGRP.

1. Neighbor table.
2. Hellow Message after 5 sec
3. K Values (Means Metric)

### 4.10.2 Troubleshooting Command

Given in Appendix

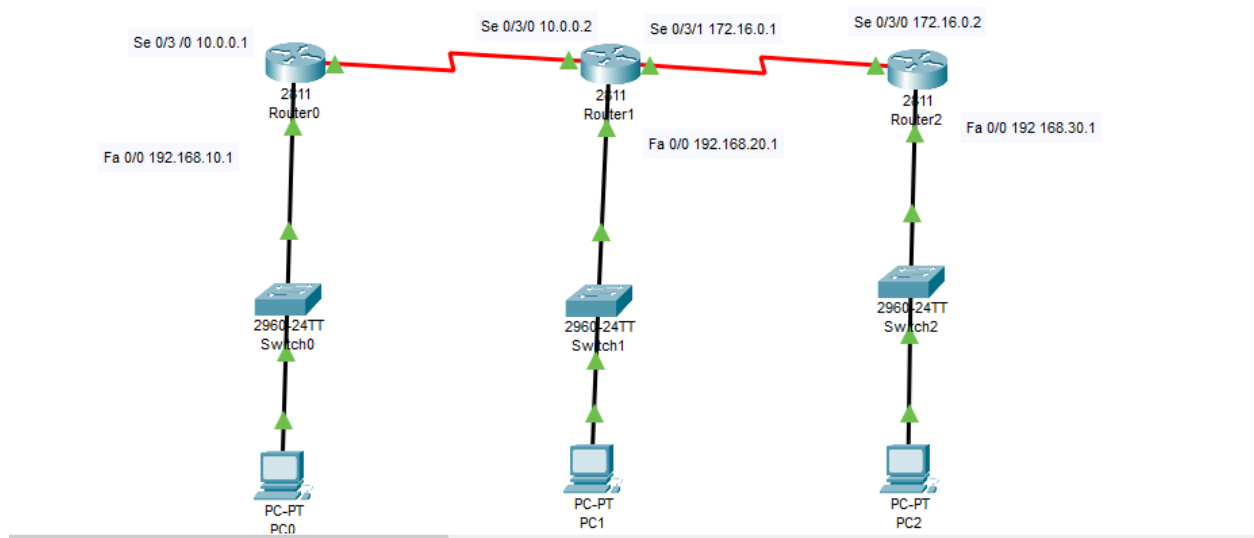

Figure 4.4 : EIGRP

## EIGRP Configuration Output

Router0#show ip route

Gateway of last resort is not set

C 10.0.0.0/8 is directly connected, Serial0/3/0

D 172.16.0.0/16 [90/2681856] via 10.0.0.2, 00:07:26, Serial0/3/0

C 192.168.10.0/24 is directly connected, FastEthernet0/0

D 192.168.20.0/24 [90/2172416] via 10.0.0.2, 00:06:48, Serial0/3/0

D 192.168.30.0/24 [90/2684416] via 10.0.0.2, 00:04:11, Serial0/3/0

Router1#show ip route

Gateway of last resort is not set

C 10.0.0.0/8 is directly connected, Serial0/3/0

C 172.16.0.0/16 is directly connected, Serial0/3/1

D 192.168.10.0/24 [90/2172416] via 10.0.0.1, 00:14:37, Serial0/3/0

C 192.168.20.0/24 is directly connected, FastEthernet0/0

D 192.168.30.0/24 [90/2172416] via 172.16.0.2, 00:10:59, Serial0/3/1

Router2#show ip route

Gateway of last resort is not set

D 10.0.0.0/8 [90/2681856] via 172.16.0.1, 00:14:10, Serial0/3/0

C 172.16.0.0/16 is directly connected, Serial0/3/0

D 192.168.10.0/24 [90/2684416] via 172.16.0.1, 00:14:10, Serial0/3/0

D 192.168.20.0/24 [90/2172416] via 172.16.0.1, 00:14:10, Serial0/3/0

C 192.168.30.0/24 is directly connected, FastEthernet0/0



## 4.11 Static Routing Configuration Guide

Static routing is the most safety way of routing. It decreases overload from network field. This type of routing generally add routes in routing table. It is useful where numbers of route are limited. Like other routing methods static routing also has its pros and cons.

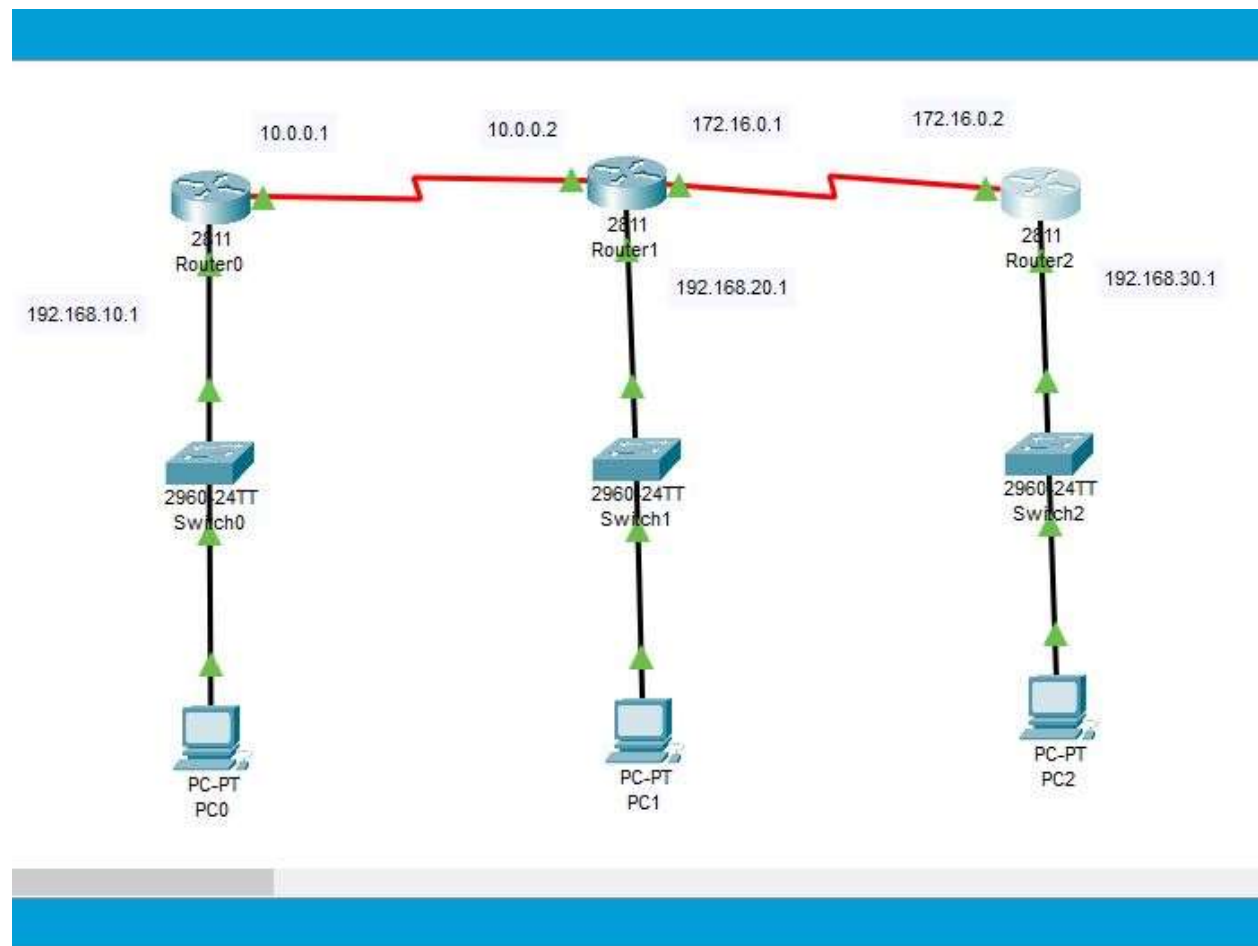

Figure 4.5: Static Routing

## Static Routing Configuration Output

Router0#

Gateway of last resort is not set

C 10.0.0.0/8 is directly connected, Serial0/3/0

C 172.16.0.0/16 is directly connected, Serial0/3/1

S 192.168.10.0/24 [1/0] via 10.0.0.1

C 192.168.20.0/24 is directly connected, FastEthernet0/0

S 192.168.30.0/24 [1/0] via 172.16.0.2

Router2#show ip route

Gateway of last resort is not set

S 10.0.0.0/8 [1/0] via 172.16.0.1

C 172.16.0.0/16 is directly connected, Serial0/3/0

S 192.168.10.0/24 [1/0] via 172.16.0.1

S 192.168.20.0/24 [1/0] via 172.16.0.1

C 192.168.30.0/24 is directly connected, FastEthernet0/0

## 4.12 Default Routing:

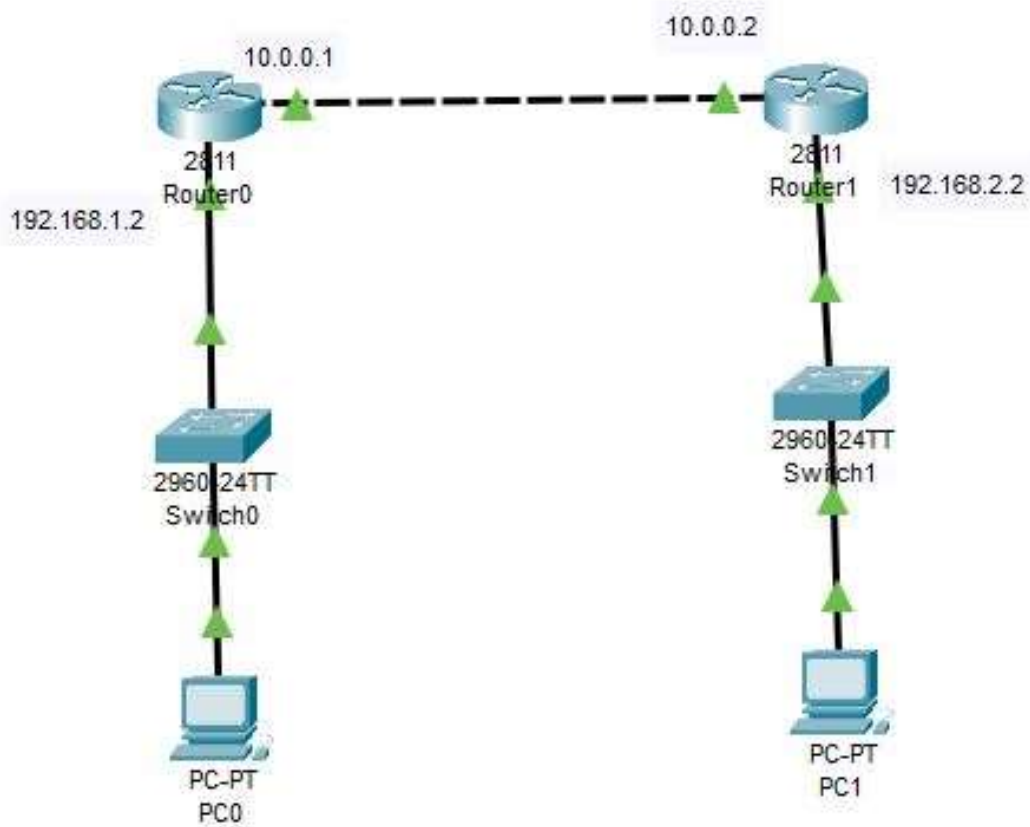

Figure 4.6:Default Routing

## Default Routing configuration Output

Router0(config)#do show ip route

Gateway of last resort is 10.0.0.2 to network 0.0.0.0

C 10.0.0.0/8 is directly connected, FastEthernet0/0

C 192.168.1.0/24 is directly connected, FastEthernet0/1

S\* 0.0.0.0/0 [1/0] via 10.0.0.2

## Router 1

--- System Configuration Dialog ---

Would you like to enter the initial configuration dialog? [yes/no]: no

## **CHAPTER 5**

### **MikroTik Router**

#### **5.1 Definition of Mikrotik Router**

MikroTik is a branding router. That is Linux type router. It was founded in 1996 to develop routers and wireless ISP systems. Now they give services about hardware and software.

That is well suited for any kinds of size. Customers that require a router which is in expensive and it's provides all of the features their network administrators necessity to secure and the monitor also. I have not found a model which is comes with an ADSL model, and I would not consider them for such network connections.[4]

#### **5.2 Router Setup Steps**

- Step 1: At first take Decide to where places the router
- Step 2: Now, Connect with the network.
- Step 3: Configure the wireless router gateway
- Step 4: Connect with gateway to the router.
- Step 5: App or web dashboard using here.
- Step 6: Make a username and set up password

#### **5.3 MikroTik Router Features[4]**

- a. Hardware Device Support
- b. Installation
- c. Configuration
- d. Backup or Restart devices
- e. Firewall Control
- f. Routing Related Device
- g. MPLS
- h. VPN
- i. Wireless
- j. DHCP Server

- k. Using Hot sopt
- l. Q o S
- m. Tools
- n. Proxy and
- o. All kinds of other feature[4]

## 5.4 MikroTik Router Interface

[4]MikroTik Router Operator System supports many kinds of network interface cards which is virtual interfaces . There are Bridge Interface, VLAN , Bonding and so on. There are having own of them sub menu . All interfaces can be configured and read in the general interfaces menu , all of them common quality properties . [4]

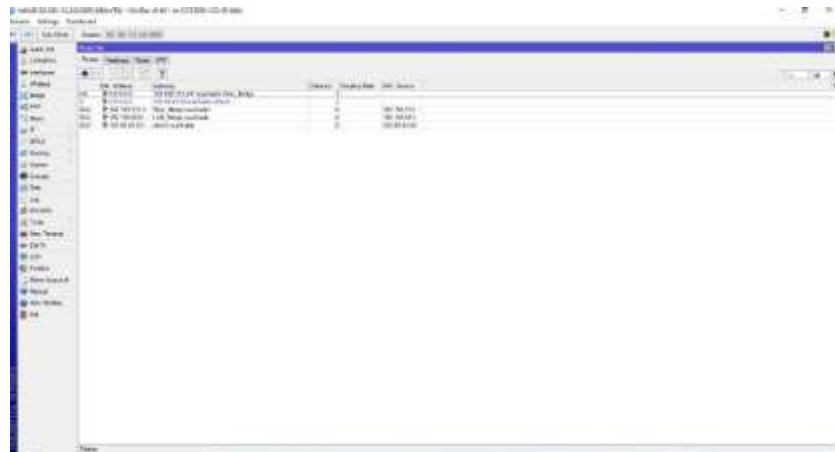

Figure 5.1: Mikrotik Interface

## 5.5 Bridge Interface

Bridge Interface accommodates diverse interfaces only one virtual interface and the bridge those interface. That is a function. Every accommodated interfaces connected to a physical segment. This segment is controlled as a one segment.

We can add an interface to a bridge. At first we will open a network setting system and then attach a new interface, which is types of bridge. Then attach a new bridge connection .After all this operation select the address of MAC .Now MAC address of the device add to the bridge.

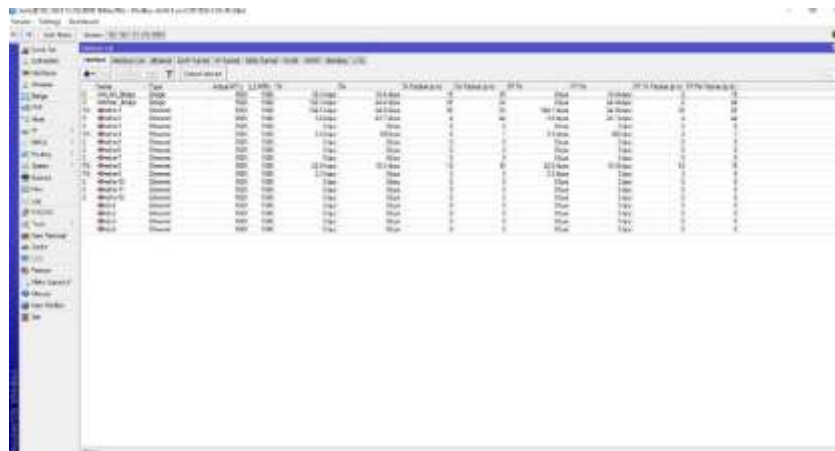

Figure 5.2: Bridge Interface

## 5.6 Concept of Bandwidth Control

B/W Control stand for Bandwidth Control. We know that is much of important peculiarity of MikroTik router. When provide the fixed Bandwidth service form ISP and distribution Local area Network (LAN) sites. If we accept or provide 50 MBPS Bandwidth form ISP and I have 20 personal computers, then how can I will provide Bandwidth into all PC. For this reason B/W maintaining device is too much important and this is necessity for data distribution all over the PC.

MikroTik router is a powerful and excellent B/W monitoring device. If we contemplate that, there are large of workers in an office and every person need internet Bandwidth but some person don't need all time Bandwidth and some person every time need Bandwidth as per his official work. Consider this matter then fix Bandwidth. We can get 20 MB Bandwidth form ISP and distribute it 20 PC. Each Computer ret 1024 kbps.

Some of them cannot use proper Bandwidth. Even that, some user have no bandwidth for this reason B/W control is needed. So we will show MikroTik router configure step by step now.

## 5.7 Configuration

### Step 1:

At first on the win box software > Queues > simple Queues > click plus >

Name = queue1 > Target Address = 192.168.10.1



Target upload, Max Limit = 1024kbps, Target Download

Max Limit = 1024kbps > Apply > Okay

**Step2:**

Again on win box > Queues > simple Queues > click plus >

Name = queue 2 > Target Address = 192.168.10.2

Target upload, Max Limit = 1024k, Target Download,

Max Limit = 1024 k > Apply > Okay

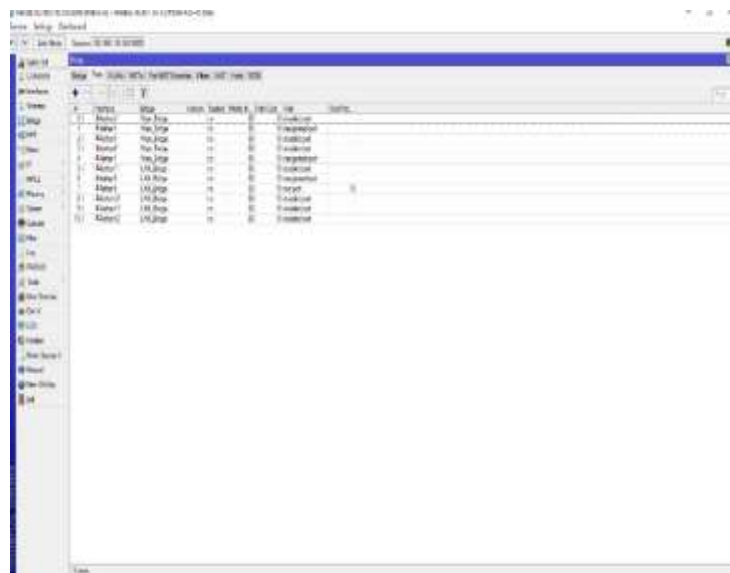

Figure 5.3: B/W Control



## 5.8.2 DHCP Server Configuration

- a. At first go to the IP > DHCP server menu from the win box. Then DHCP server window will present.
- b. Now DHCP Server window, then touch on the DHCP Setup button and choose the interface which is necessary for setup DHCP server from same quality server. Drop down the interface and then click the next button.
- c. LAN and close the DHCP address Space on the input box. Now click on the next step button. Client got IP address.
- d. Choose gateway address for the given network in gateway for DHCP Network input box and then click the next button.
- e. Give IP range from the DHCP client or LAN user will be get IP address to provide outside input box and now click on the next button.
- f. Give DNS server IP and then click Next button.
- g. IP lease time. Now click on the up next button. Default lease time is 3 days, which is automatically setup.
- h. DHCP setup is complete now and this is successful message will be shown here.  
Now connect any IP device as like Laptop, Desktop, Smartphone and so on to the network.

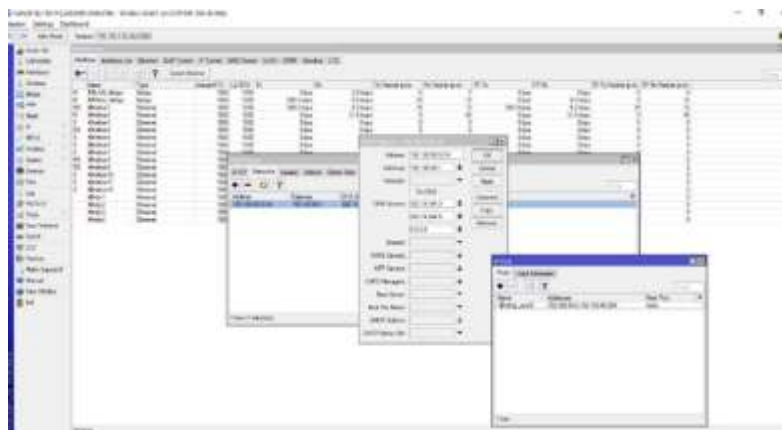

Figure 5.5: DHCP Server Configuration



Figure 5.6 : IP Address Assigned

## 5.9 NAT

Network Address Translation. That is system for more than one map which is local and private addresses to a public one before the transferred the data and information also. Want to much devices to work a single IP address use Network Addresses Translation. As like as maximum are same to home or personal routers. [5]

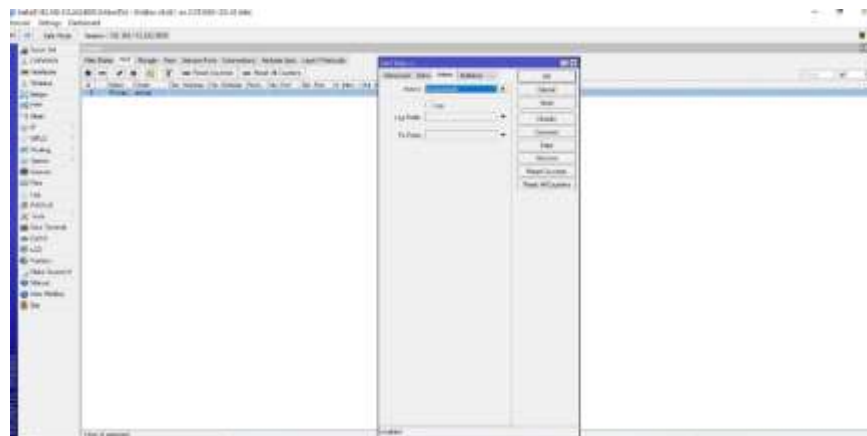

Figure 5.7: NAT Routing

## 5.9.1 Working Procedure of NAT

It allows single types devices. As like as router to act as an leader between the internet. On the other hand we can say that public network and local network. That is means only a single unique IP address is required to represent an all over the group computers for any kinds of outside for their own network .[5]

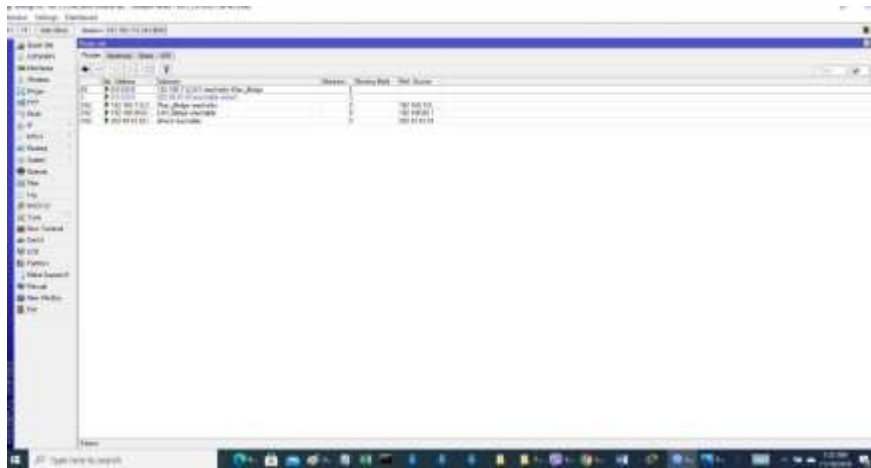
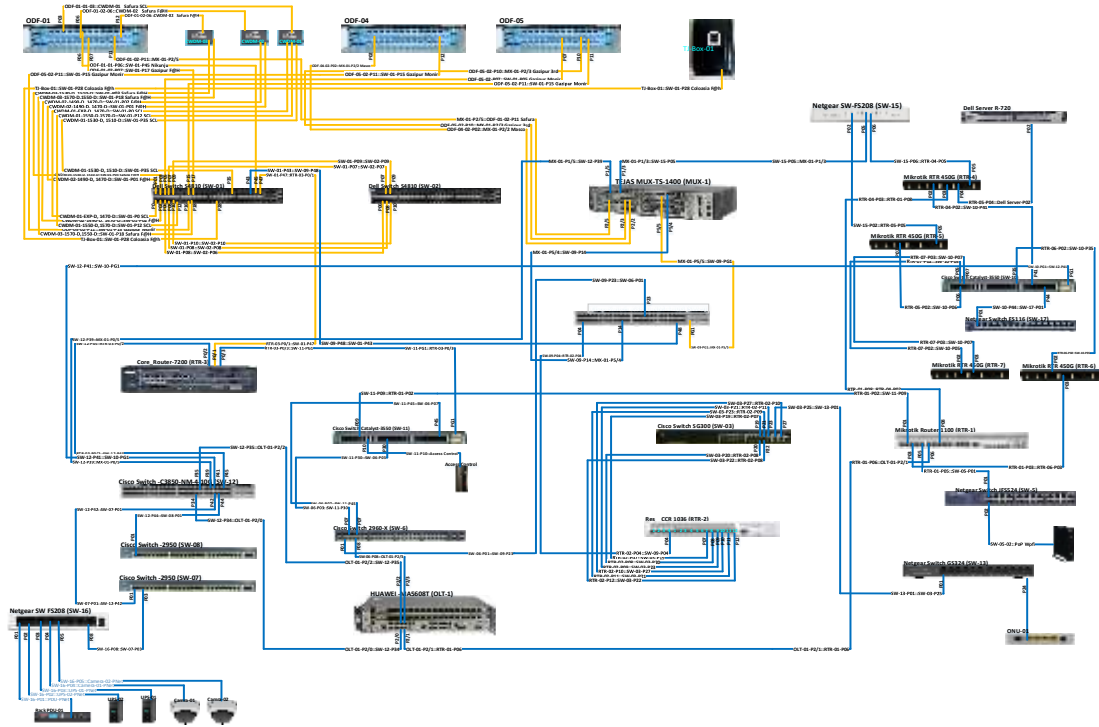

Figure 5.8: NAT Routing Configuration

# ISP Network Diagram

IPS Network Diagram



## CHAPTER 6

### Conclusions

I got much of opportunity to work on the Aamra Network Limited. There are many ways and gathered a lot of experience throughout the entire internship session. There was a scope in the field of computer office network planning and designing, working on this field. Data and internet connectivity, ensuring network security, different types of application configuration, and maintenance. In this report, I have explained my experiences with Office Network Setup, Designing and Optimization also. I have discovered much of good sized processes from my supervisors and carried out some of duties on an ordinary basis during my complete Internship duration and ultimately learned the confidence to address venture myself. I think that far an excellent possibility to apply the knowledge and skills that I had acquired from them. I also learned the way to take care of essential faults and got new thoughts every day. Doing this sort of work is virtually useful for my future profession and I am trying to this form of paintings once more.

Actual getting to know comes on the cease of the working length while I used to be given the possibility to consider what I saw and what I skilled in experimental teaching and internship session. I exploit the proper business etiquette to study with the aid of gazing clients and professional etiquette and gaining knowledge of the way to communicate with expert caregivers and another group of workers, as well as an expert within the discipline. I'm imposing the strategic vision of a corporation, how to connect to colleagues, a way to proportion assets, how to arrange, how to make choices, a few technical cognizance's of the business enterprise's surroundings, and the organization's responsibility and responsiveness. The internship revel in on the quilt of my internship manager via an assessment and individual meetings offers a possibility of searching for an expert opinion. I think that, this internship will help me of my future career. That is learned me that how way working with other team members and how way treat to all of other them.

## **Future Outcome:**

I achieve a lot of knowledge about the network through by in this internship. It was helpful for myself. May it will be help me for my future life and professional career also.

- a. For this internship experience help me for got a good job.
- b. I can start a ISP business.
- c. I gather knowledge about this field, so that I can try work on this area such as a skilled.
- d. This internship can may help for Bank Job.
- e. I can take preparation for CCNA Exam.
- f. Help me for make a network design.



# Appendixes

## Appendix A: Internship Reflection

The true knowledge is that I have put an end to the length of the work. Used to give compliments to the consider what I saw and what gifts I gave Search guidance and internship. I abuse that the proper trade behavior. Think with the help of clients and efficient behavior and picking Ways to communicate with the master caregiver and another. A bunch of experts, as well as a master within the teacher. I'm pressing the key. An entrepreneurial approach, how to engage with colleagues, ways to increase resources, some special knowledge work on how to orchestrate, how to make choices. The environment of trade enterprise, and the duties of the organization and Feedback Internship Glad knitting by my internship director. An evaluation medium and offers an indulgence to look for individual assemblies Guess a master.

## Appendix B: Company Details

Name : Aamra Networks Limited  
Address : Safura Tower (9,12 and 15<sup>th</sup> floor), 20 Kemal  
Ataturk Avenue, Banani, Dhaka-1213, Bangladesh  
Telephone: 88 022222 81100  
E-mail : info.networks@aamra.com.bd  
Website : [www.aamranetworks.com](http://www.aamranetworks.com)  
Types of Company: Tr 1 and Tr 2  
Employees : More than 500+

## References:

[1] Learn about IP Address. Available at Book Name: Cisco Certified Network Associate(**Todd Lammle**) Sixth Edition, Wiley publishing 2007, Page, 113-135, 383-398, 417-438.

[2] Learn about Subnet mask. available at

<<https://www.techopedia.com/definition/28328/subnetting>> Last Access on 3.49pm 03-01-2022.

[3] Learn about RIP(Routing information Protocol), available at  
<<https://www.guru99.com/routing-protocol-types.html>> Last Access 3.57pm 03-01-2022.

[4] Learn About Mikrotik Router. Available at  
[https://wiki.mikrotik.com/wiki/Manual:IP/DHCP\\_Server](https://wiki.mikrotik.com/wiki/Manual:IP/DHCP_Server) Last Access on 4.03pm 03-01-2022.

[5] Learn about NAT (Network Address Translation), available at  
<https://wiki.mikrotik.com/wiki/Manual:IP/Firewall/NAT> . Last Access on 4.10pm 03-01-2022

## INTERNET SERVICE PROVIDER (ISP)

### ORIGINALITY REPORT

30%

SIMILARITY INDEX

28%

INTERNET SOURCES

6%

PUBLICATIONS

14%

STUDENT PAPERS

### PRIMARY SOURCES

1

[dspace.daffodilvarsity.edu.bd:8080](http://dspace.daffodilvarsity.edu.bd:8080)

Internet Source

17%

2

Submitted to Kingston University

Student Paper

4%

3

[www.slideshare.net](http://www.slideshare.net)

Internet Source

1%

4

Submitted to Daffodil International University

Student Paper

1%

5

[www.apnic.net](http://www.apnic.net)

Internet Source

1%

6

Submitted to TMG College Australia

Student Paper

1%

7

[www.aspell.org](http://www.aspell.org)

Internet Source

1%

8

[blog.unsri.ac.id](http://blog.unsri.ac.id)

Internet Source

<1%

9

[www.coursehero.com](http://www.coursehero.com)

Internet Source

<1%