

Smart Rajshahi: A Cross-platform Application

BY

Kawsar Ali
ID: 201-15-14060

This Report Presented in Partial Fulfillment of the Requirements for the Degree
of Bachelor of Science in Computer Science and Engineering

Supervised By

Dewan Mamun Raza
Senior Lecturer
Department of CSE
Daffodil International University

Co-Supervised By

Ms. Asma Mariam
Lecturer
Department of CSE
Daffodil International University



DAFFODIL INTERNATIONAL UNIVERSITY

DHAKA, BANGLADESH

JANURAY 2023

APPROVAL

This Project titled “**Smart Rajshahi: A Cross-platform Application**”, submitted by **Kawsar Ali** the Department of Computer Science and Engineering, Daffodil International University, has been accepted as satisfactory for the partial fulfillment of the requirements for the degree of B.Sc. in Computer Science and Engineering and approved as to its style and contents. The presentation has been held on March 24,2022.

BOARD OF EXAMINERS



Dr. Touhid Bhuiyan
Professor and Head

Department of Computer Science and Engineering
Faculty of Science & Information Technology
Daffodil International University

Chairman



Subhenur Latif
Assistant Professor

Department of Computer Science and Engineering
Faculty of Science & Information Technology
Daffodil International University

Internal Examiner



Tania Khatun
Assistant Professor

Department of Computer Science and Engineering
Faculty of Science & Information Technology
Daffodil International University

Internal Examiner



Md. Safaet Hossain
Associate Professor & Head

Department of Computer Science and Engineering
City University

External Examiner

DECLARATION

I hereby declare that, this project has been done by me under the supervision of **Mr. Dewan Mamun Raza, Senior Lecturer, Department of CSE** Daffodil International University. I also declare that neither this project nor any part of this project has been submitted elsewhere for award of any degree or diploma.

Supervised by:



Mr. Dewan Mamun Raza
Senior Lecturer
Department of CSE Daffodil
International University

Co-Supervised by:



Ms. Asma Mariam
Lecturer
Department of CSE
Daffodil International University

Submitted by:

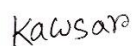

Kawsar Ali
ID: 201-15-14060
Department of CSE
Daffodil International University

ACKNOWLEDGEMENT

In preparing this thesis, I was in contact with many people, researchers, academicians, and practitioners. They have contributed towards my understanding and thoughts.

First of all, I thanked Allah for providing me with a once-in-a-lifetime chance to accomplish my Final Year Project. I'd want to offer my deepest thanks to my parents and family for their unconditional support, both mentally and physically, during my time at Daffodil International University.

In particular, I wish to express my sincere appreciation to my main project supervisor Dewan Mamun Raza, for encouragement, guidance, critics and friendship. It would have been difficult to progress without her continuous support. I am also very thankful to my project supervisor for her guidance, advices and motivation.

My fellow student's support should also be credited. My sincere gratitude also goes out to all of my friends and those who have helped me at separate times. Their suggestions and opinions are quite helpful. Unfortunately, there isn't enough room to mention them all in this area. I am grateful to every member of my family

ABSTRACT

The development and implementation of the Smart Rajshahi are the objectives of is project. The Smart Rajshahi idea offers an appealing framework for the development of IT-enabled services. It presents a picture of the city where service providers interact with residents using information technology to build better urban organizations and systems that can enhance quality of life. Through this application citizens will be able to submit issues like Miscellaneous Certificates, Dispute resolution, Rent of Corporation premises, Trade License New, Renewal of Trade License, Application for Advertisement (Registration), Registration in private educational institutions coaching centers, Registration of premises , Environmental pollution complaints, Response to Environmental Pollution, Garbage removal and Construction material removal truck rental garbage, water and gas supply problem and so on to the concerned officials, employees and councilors of Rajshahi district. This system being developed using the flutter.

TABLE OF CONTENTS

CONTENTS	PAGE
Approval	ii
Declaration	iii
Acknowledgements	iv
Abstract	v
CHAPTER	
CHAPTER 1: INTRODUCTION	10
1.1 Smart Rajshahi system	10
1.2 Project initiation planning	11
1.3 Project motivation	11
1.4 Objectives	12
CHAPTER 2: METHODOLOGY	13
2.1 Concept	13
2.1.1 Flutter Framework	13
2.1.2 Dart	13
2.1.3 Flutter package	14
2.1.4 SQFlite	14
2.1.5 DBMS	15
2.1.6 Rest Api	15
2.1.7 Google Font Flutter	15
2.1.8 Font Awesome Icons	16
CHAPTER 3: Requirement Specification	17
3.1 Database design	17
3.2 Entity relationship model	17
3.3 Entity relationship diagram	18
3.4 Use case diagram	20

3.4.1 Use Case List	21
3.4.2 Use Case Description	22
3.5 Class diagram	25
3.6 Tables	25
3.8 Sequence Diagram	28
CHAPTER 4: IMPLEMENTATION AND TESTING	31
4.1 Implementation of Database	31
4.1.1 Database Design	31
4.2 Implementation of Front-end Design	32
4.2.1 Login	32
4.2.2 Home	33
4.2.3 Administrative	33
4.2.4 Engineering	34
4.2.5 Health	34
4.2.6 Revinue	35
4.2.7 Notice	35
4.3 Overall Development	36
4.4 Testing Implementation	36
4.5 Test Reports and Results	37
CHAPTER 5: APLLICATION DESIGN AND DESCRIPTION	38
5.1 Home	38
5.2 Registration	39
5.3 Notice	35
5.4 Registration	40
5.6 Login	40
5.7 User Profile	41
5.8 Department list	43
5.9 Engineering	44
5.10 Revenue	47
5.11 Administrative	47
5.12 Health	47

5.13 Waste Management	49
5.14 Notice	49
CHAPTER 6: CONCLUSION AND FUTURE SCOPE	
6.1 Discussion and Conclusion	52
6.2 Limitations	52
6.3 Scope for Future Developments	53
REFERENCES	53
	54

5

LIST OF FIGURES

FIGURE NAME	PAGE NO
Figure 3.1: Database design	17
Figure 3.2: Entity relationship diagram	17
Figure 3.3: Entity relationship diagram	17
Figure 3.4: Use case diagram	20
Figure 3.5: Class diagram	25
Figure 3.7.1: Admin Table	26
Figure 3.7.2: User Table	27
Figure 3.8.1: Sequence diagram	28
Figure 3.8.2: Sequence diagram	30
Figure 4.2.1: Login	32
Figure 4.2.2: Home	32
Figure 4.2.3: Administrative	33
Figure 4.2.4: Engineering	33
Figure 4.2.5: Health	34
Figure 4.2.6: Revenue	34
Figure 4.2.7: Notice	36
Figure 5.1: Home	38
Figure 5.2: Registration	39
Figure 5.3: Login	40
Figure 5.4: User Profile	41
Figure 5.5: Department List	42
Figure 5.6: Administrative	43
Figure 5.7: Engineering	44
Figure 5.8: Revenue	47
Figure 5.9: Health	47
Figure 5.10: Waste management Department	49
Figure 5.11: Notice	49

LIST OF TABLES

TABLE NAME	PAGE NO
Table 3.4.2.1: Use case 1	22
Table 3.4.2.2: Use case 2	22
Table 3.4.2.3: Use case 3	23
Table 3.4.2.4: Use case 4	23
Table 3.4.2.5: Use case 5	23
Table 3.4.2.6: Use case 6	24
Table 3.4.2.7: Use case 7	24
Table 3.4.2.8: Use case 8	24
Table 3.4.2.9: Use case 9	24
Table 3.7.2: Admin Table	26
Table 4.1: Test Case	36

CHAPTER 1

INTRODUCTION

Smart Rajshahi is a citizen engagement management platform that allows Rajshahi citizens to easily access services offered by the corporation in Rajshahi's service zones. Rajshahi residents can install this app on their Android handsets. Smart City (Smart Rajshahi) System Application has been developed for all types of services provided to Rajshahi district residents. An administrator enters all of the data in this framework. Data may be accessed from anywhere in the globe over the web using smart mobile phones, PCs, and other associated devices. In this framework service recipient of Rajshahi can take all services like: administration department, engineering department, revenue department, health department and waste management system. Through this application, citizens will be able to submit issues like Water and gas services, Miscellaneous Certificates, Dispute resolution, Rent of Corporation premises, Trade License New, Renewal of Trade License, Application for Advertisement (Registration), Registration in private educational institutions coaching centers, Registration of premises , Environmental pollution complaints, Response to Environmental Pollution, Garbage removal and Construction material removal truck rental directly to the concerned officials, employees and councilors of Rajshahi [1].

1.1 Smart Rajshahi System

Smart Rajshahi System that controls all types of department services information and an automated procedure that provides more accuracy and reduces mistakes[2]. Rajshahi citizens can benefit from this system. A large part of departments like providing financial assistance, city corporation space rent, water and gas service, contractor license, Application for land use no objection clearance, Dispute resolution, can apply for Application for new holdings, garbage removal, medical registration, Succession certificate, and many more things. So, many facilities offer all of the systems[3]. The citizens of Rajshahi receive all information about Smart Rajshahi and its departments in a distributed way. To replace the system, a smart Rajshahi system was created and implemented. My system will manage the following departmental information: administration department, engineering department, revenue department, health department and waste management department. And their services. Services are department wise: **Administration Department** (Divorce, Miscellaneous Certificates, Dispute resolution, Rent of Corporation premises, providing financial assistance, Succession certificate) **Engineering Department** (Water and gas services, Vehicle equipment rental, Enrolled in contractor's license,

Application for No Objection Clearance for Land Use) Revenue Department (Trade License New, Renewal of Trade License, Application for Advertisement (Registration), Application for Advertisement (Renewal), Nomenclature Application (Holding), Application for new holding, Holding Tax Review, Registration in private educational institutions coaching centers, Nomenclature Application (Holding), Renovation of coaching centers in private educational institutions) Health Department (Registration of premises , Environmental pollution complaints, Response to Environmental Pollution, Complaints, Medical registration, Pet license) Waste Management Department (Garbage removal, Construction material removal truck rental). The main purpose of this system is to easily accessed by both admin and users to Smart Rajshahi.

Project initiation planning

This project's only member is myself. This is the outcome of my ideas and work and effort. Initially, I had various ideas for my final project. I couldn't determine what my project would be. At the time, I saw that my city had different departments that provided various services to Rajshahi citizens. However, my city lacked a centralised source for all municipal-related information. Regarding various city departments, we lacked clear information. Additionally, we had little knowledge of the service departments. As I saw this circumstance, I had a thought for my project. After consulting with the authority and my supervisor, I settled on this specific project since I believe it is desperately needed by all Rajshahi residents. Then I started working on my project. My supervisor had provided me with valid advice and information.

1.3 Project motivation

Bangladesh is a developing country, and every sector is going digital. The ICT division is aware of this and is working to grow quickly, and our college is also IT-based. Each semester, the Department of Computer Science and Engineering graduates a significant number of understudies with their final project [4]. Diverse students choose their assignments for a variety of reasons, each with a unique thought process. It is wise to choose an effective project. Since completing an assignment isn't just for academic credit but also for doing your part for the community. If I look at my existing diversified structure, I can see that a big amount of it is manual, distributed, and has various problems. Therefore, I believe that I can convert a scattered framework into a single location using automated mechanization for everyone. Despite the fact that many students have tried it before without success [5]. As a result, I'm making an effort to move forward legally and have chosen the term "Improvement of Smart Rajshahi System Application" for my project. I might wish to show off my shrewd ideas. In my deeper heart, I believe that it is my duty to take on an effort that is both effective and doable for my country

and college overall.

1.1 Objective of this project

There are several goals for this project. The following list of key goals includes:

- To provide every information in an efficient way.
- To provide each and every update to the user instantly.
- To maintain the services of city departments properly.
- To provide an online smart city (Smart Rajshahi).
- To provide a better service to citizen of Rajshahi.

CHAPTER 2

METHODOLOY

The "**DEVELOPMENT OF SMART RAJSHAHI SYSTEM APPLICATION**" was created to handle services in our Rajshahi city in the simplest and most effective way possible, so that Rajshahi inhabitants may quickly go from one department to another. I created this system with the intention of providing online services to my district's services as well as using it in numerous department fields. In reality, this might be used as a comprehensive municipal services system.

2.1 Concept

- Flutter
- Dart
- Flutter Package
- SQFLITE
- Database
- Rest API
- Google fonts
- Font Awesome Icons

2.1.1 Flutter Framework

Flutter is an open-source framework to create high quality, high performance mobile applications across mobile operating systems - Android and iOS. It offers a straightforward, strong, effective, and simple SDK that makes it simple to create mobile applications in Dart, Google's own programming language. This lesson explains the fundamentals of the Flutter framework, how to install the Flutter SDK, how to set up Android Studio to create Flutter-based applications, and how to create various types of mobile applications using the Flutter framework [6].

2.1.2 Dart

Dart is a high-level, general-purpose programming language that was created by Google. The new programming language debuted in 2011, but its stable version wasn't made public until June 2017 [7]. When the Flutter uses dart, it becomes more popular than it was at the

time. Closure and lexical scope are features of the dynamic, class-based, object-oriented programming language Dart. It is very similar to Java, C, and JavaScript in terms of syntax [8]. You can learn Dart with ease if you are familiar with any of these programming languages. Dart is an open-source programming language that is frequently used to create Internet of Things (IoT) apps, modern web applications, desktop applications, and mobile applications.

2.1.3 Flutter Package

According to the Flutter docs, packages are described as shareable packages that are provided to the Flutter and Dart ecosystems by other developers. Without having to start from scratch, this enables developers to quickly create an app [9].

2.1.4 SQFLITE

Flutter SQFLITE plugin enables MacOS, iOS, and Android. It handles batches and transactions. On iOS and Android, automatic version management for open Helpers for insert, query, update, and delete DB operations are carried out in a background thread. Different platforms provide: Support for SQFLITE common on Linux, Windows, and Dart VM. There is no support for Web. Examples of usage Simple flutter notepad compatible with Windows, Linux, Mac, iOS, and Android is notepad SQFLITE [10].

2.1.5 DBMS

A database is a dealt with amassing of data. The data are usually made to indicate relevant pieces of reality in a manner that supports shapes requiring this information. For example, showing the availability of rooms in hotels in a way that supports finding a motel with circumstances.

Database the administrators systems (DBMSs) are remarkably arranged applications that work together with the customer, distinctive applications, and the database itself to catch and separate data. A comprehensively valuable database the board system (DBMS) is an item structure expected to allow the definition, creation, addressing, revive, and association of databases. For my application I have used MySQL [10].

2.1.6 Rest API

Application programming interface, or API for short, is a collection of definitions and protocols used to create and integrate application software.

REST is neither a protocol or a standard; it is a set of architectural restrictions. REST can be implemented in many different ways by API developers.

A RESTful API transmits a representation of the resource's state to the requester or endpoint when a client request is made through it. One of various formats, including JSON (Javascript Object Notation), HTML, XLT, Python, PHP, or plain text, is used to send this information or representation via HTTP. Despite its name, JSON is the most widely used file format because it can be read by both humans and machines and is language-independent [11].

2.1.6 Google Font Flutter

A font is a graphic representation of text that may be printed or displayed and can have various typefaces, point sizes, weights, colors, and designs. The typeface is the type design used for a group of fonts, and the typeface family is made up of variations on this design. Numerous fonts of a typeface family may come in various weights, styles, and sizes. Serif, sans serif, scripts, and decorative types can be split into four fundamental categories for the most part. Sans serif typefaces lack the tiny lines (serifs) that serif typefaces have at the ends of the strokes that form the letters and symbols (sans is French for without) [12]. Script typefaces are based on the connected, fluid strokes of handwriting, whereas decorative typefaces are purely decorative and are not meant to be used for long text setting. There are tens of thousands of different typefaces in use, and more are always being created. Selecting the appropriate

typeface for your Flutter project is an important choice that can significantly affect the final app's appearance and feel. The main Font Awesome is so far open source and absolutely free for business subjects, modules, and endeavors [13]

2.1.8 Font Awesome Icons

Flutter provides an inbuilt icon pack for your app to use, however it only has a small selection of icon sets, so you must rely on additional icon packs. One of the best icon sets for flutter or web applications is Font Awesome.

CHAPTER 3

Requirement Specification

3.1 Database design

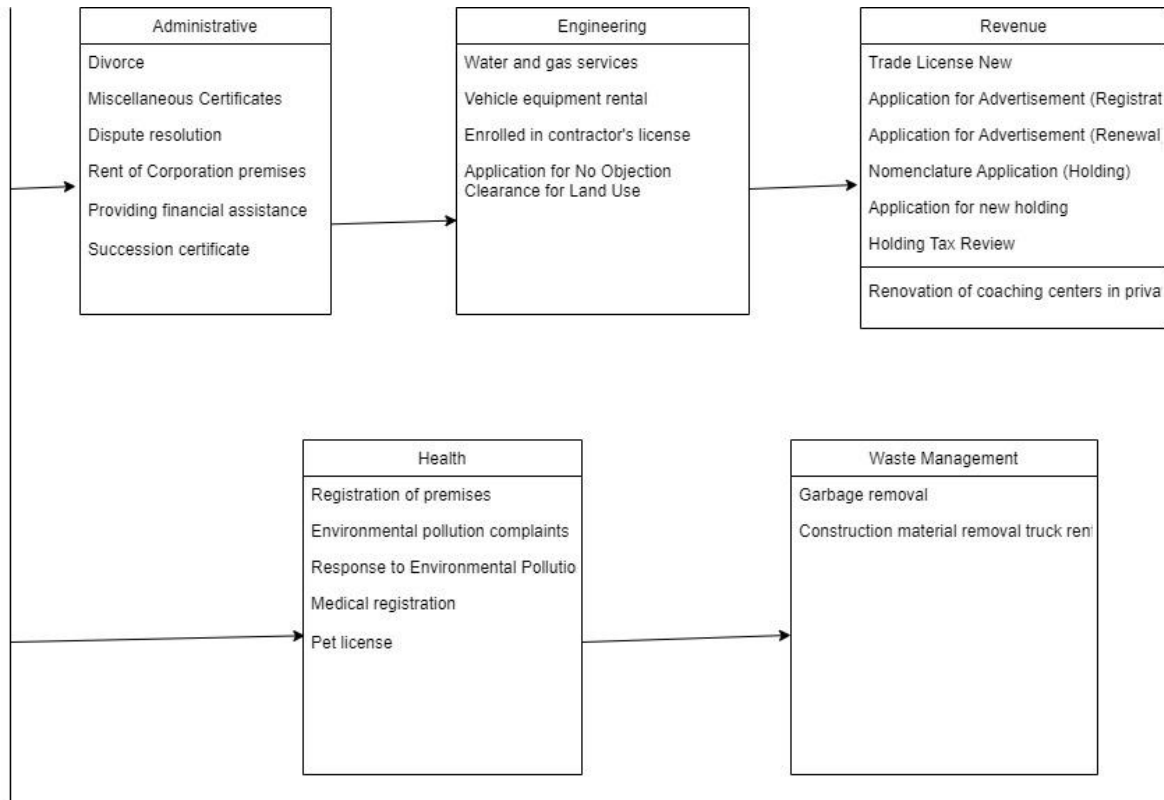
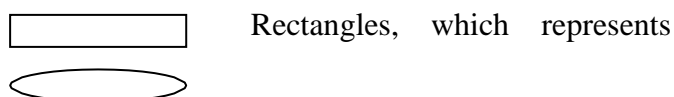

Figure 3.1: Database design of the system.

3.1 Entity relationship model

A visual representation of entities and their connections to one another is an element relationship model. To accurately capture this current reality in a database is the primary goal of ER demonstrations. We don't really get a database representation from the ER display. It provides us a little advantage that makes describing a database not too complex. Usually, an ER display is actualized as a database. Each column of a table in a simple social database refers to one instance of a substance type, and each field refers to a characteristic type. A link between items in a relational database is established by storing the primary key of one element as a pointer, or "foreign key," in the table of another element [14].

Figure 3.2 below lists the E-R diagram's main elements.



entity set. Ellipse, which represents attributes.

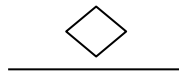

Diamonds, which represents relationship sets.

Line, which link attributes to entity sets and entity sets to relationshipsets.

3.1 Entity relationship diagram

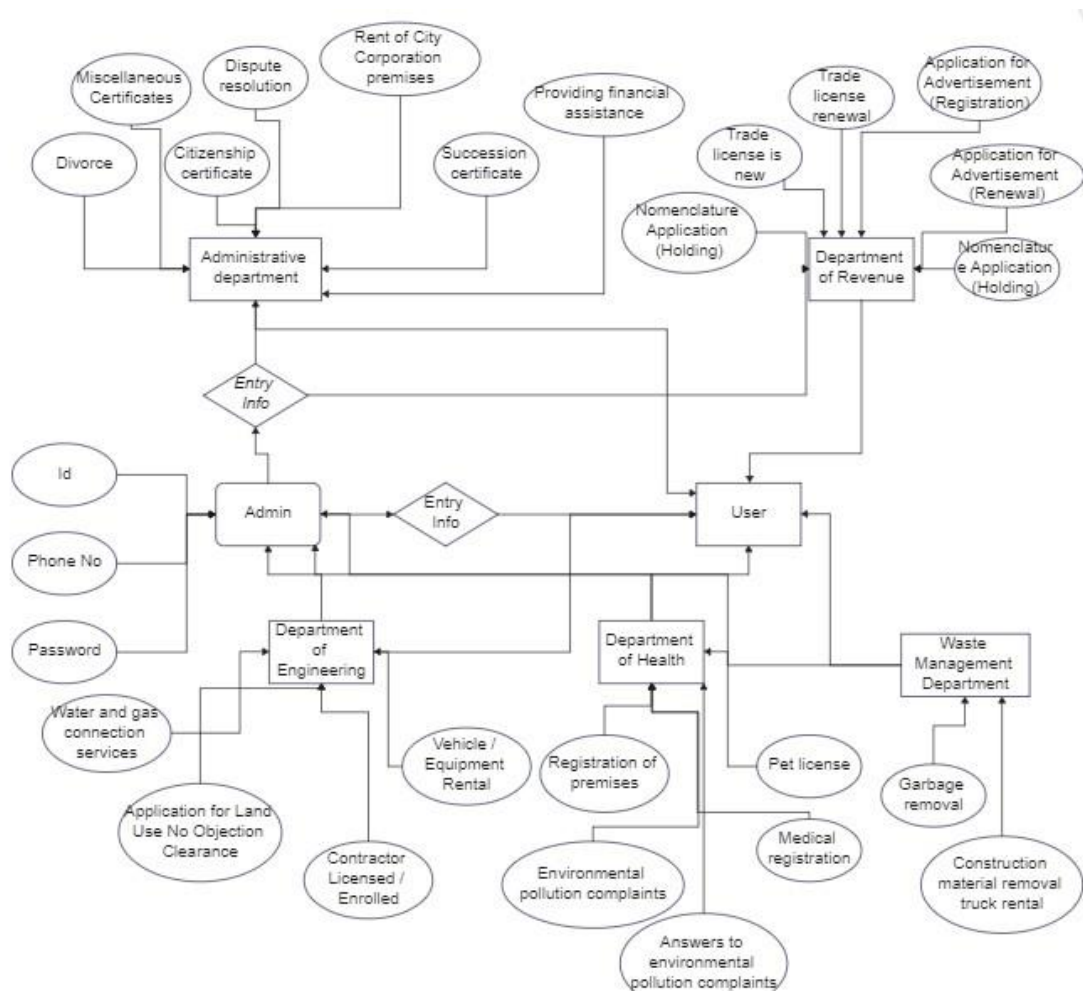

Figure: 3.3 representing different relationship between the entities of the system.

3.1 Use Case diagramActors:

Admin: Admin can set, update and delete the information.

User: User can view and send all the information related to the services.

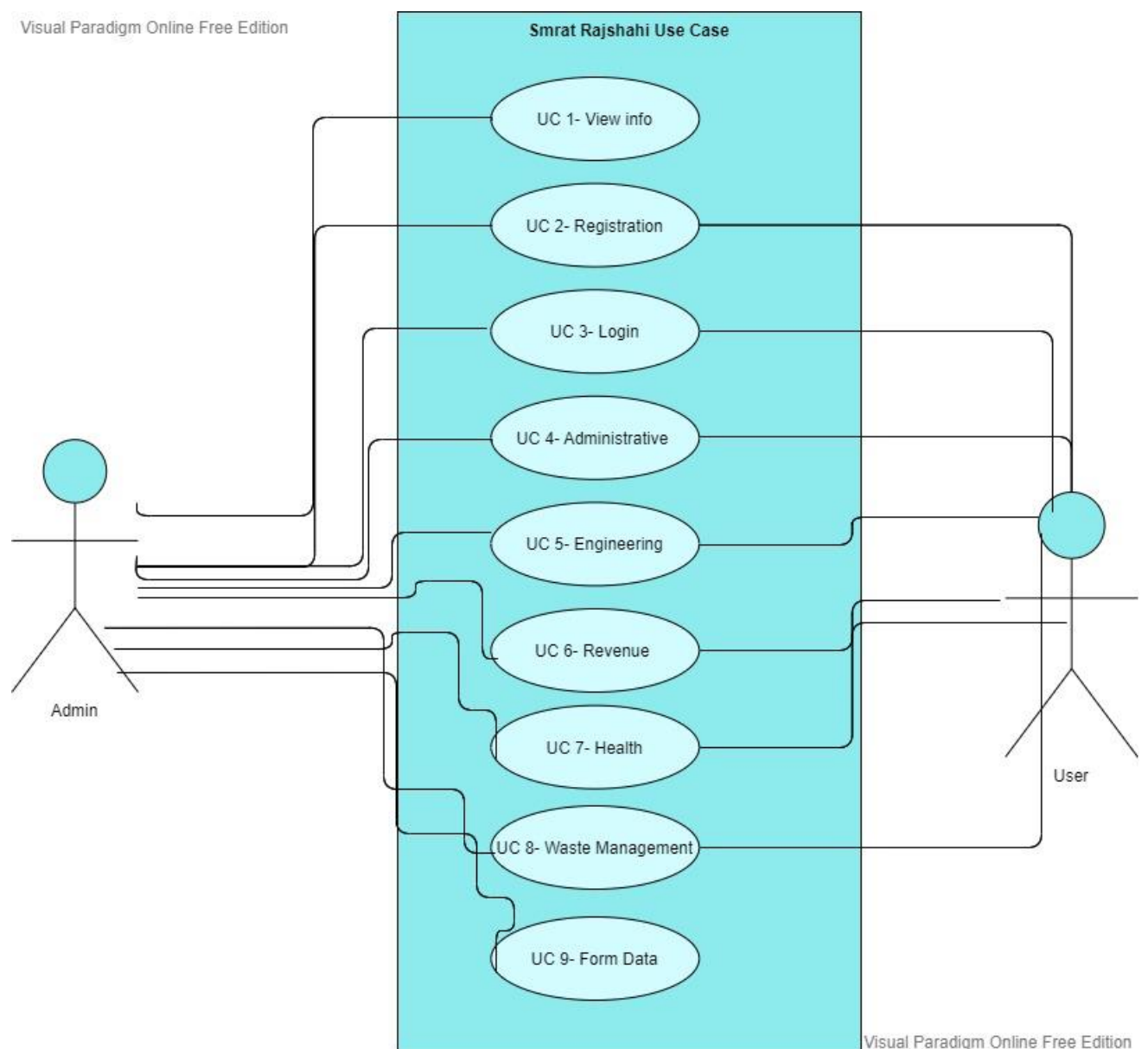

Figure 3.4: Use case diagram of the system.

Use Case List:

- **UC 1- View info:** User can view information of the city services.
- **UC 2- Registration:** Admin and User can registration.
- **UC 3- Login:** Admin and User can login.
- **UC 4- Administrative Department:** Admin can set, update and delete the administrative department service and user can upload and sent message.
- **UC 5- Engineering Department:** Admin can set, update and delete the engineering department service and user can upload and sent message.
- **UC 6- Revenue Department:** Admin can set, update and delete the revenue department service and user can upload and sent message.
- **UC 7- Health Department:** Admin can set, update and delete the health department service and user can upload and sent message.
- **UC 8- Waste Management Department:** Admin can set, update and delete the waste management department service and user can upload and sent message.
- **UC 9- Form Data:** Admin can set, update and delete the form data information and user can send the data.

Use Case Description:

Table 3.4.2.1 Use case 1

Use Case Id: 1

Use Case Name:	View Info
Created By:	Kawsar Ali
Date Of Creation:	25-11-2022
Description:	This use case will allow user to view information of the city services
Primary Actor:	User
Secondary Actor:	None
Precondition:	None
Post condition:	The system will display the home page

Table 3.4.2.2 Use case 2

Use Case Id:	2
Use Case Name:	Registration

Created By:	Kawsar Ali
Date Of Creation:	25-11-2022
Description:	This use case will allow admin and user to registration in the system.
Primary Actor:	Admin and User
Secondary Actor:	None
Precondition:	None
Post condition:	The system will display the Registration page

Table 3.4.2.3 Use case 3

Use Case Id:	3
Use Case Name:	Login
Created By:	Kawsar Ali
Date Of Creation:	25-11-2022
Description:	This use case will allow admin and user login in the system.
Primary Actor:	Admin and User
Secondary Actor:	None
Precondition:	None
Post condition:	The system will display the login page

Table 3.4.2.4 Use case 4

Use Case Id:	4
Use Case Name:	Administrative Department
Created By:	Kawsar Ali
Date Of Creation:	25-11-2022
Description:	This use case will allow admin to set, update and delete the administrative department service and user can upload and sent message.
Primary Actor:	Admin and User
Secondary Actor:	None
Precondition:	None
Post condition:	The system will display the administrative department page.

Table 3.4.2.5 Use case 5

Use Case Id:	5
Use Case Name:	Engineering Department
Created By:	Kawsar Ali
Date Of Creation:	25-11-2022
Description:	This use case will allow admin to set, update and delete the engineering department service and user can upload and sent message.
Primary Actor:	Admin and user
Secondary Actor:	None
Precondition:	None
Post condition:	The system will display the engineering department.

Table 3.4.2.6 Use case 6

Use Case Id:	6
Use Case Name:	Revenue Department
Created By:	Kawsar Ali
Date Of Creation:	25-11-2022
Description:	This use case will allow admin to set, update and delete the revenue department service and user can upload and sent message.
Primary Actor:	Admin and User
Secondary Actor:	None
Precondition:	None
Post condition:	The system will display the schedule revenue department page

Table 3.4.2.7 Use case 7

Use Case Id:	7
Use Case Name:	Health Department
Created By:	Kawsar Ali
Date Of Creation:	25-11-2022
Description:	This use case will allow admin to set, update and delete the health department service and user can upload and sent message.
Primary Actor:	Admin and User
Secondary Actor:	None
Precondition:	None
Post condition:	The system will display the health department page.

Table 3.4.2.8 Use case 8

Use Case Id:	8
Use Case Name:	Waste Management Department
Created By:	Kawsar Ali
Date Of Creation:	25-11-2022
Description:	This use case will allow admin to set, update and delete the waste management department service and user can upload and sent message.

Primary Actor:	Admin and user
Secondary Actor:	None
Precondition:	None
Post condition:	The system will display the waste management department page.

Table 3.4.2.9 Use case 9

Use Case Id:	9
Use Case Name:	Form Data
Created By:	Kawsar Ali
Date Of Creation:	25-11-2022
Description:	This use case will allow admin to set, update and delete the form data information and user can send the data after fill up the form.
Primary Actor:	Admin and user
Secondary Actor:	None
Precondition:	None
Post condition:	The system will display the form data page.

3.1 Class diagram

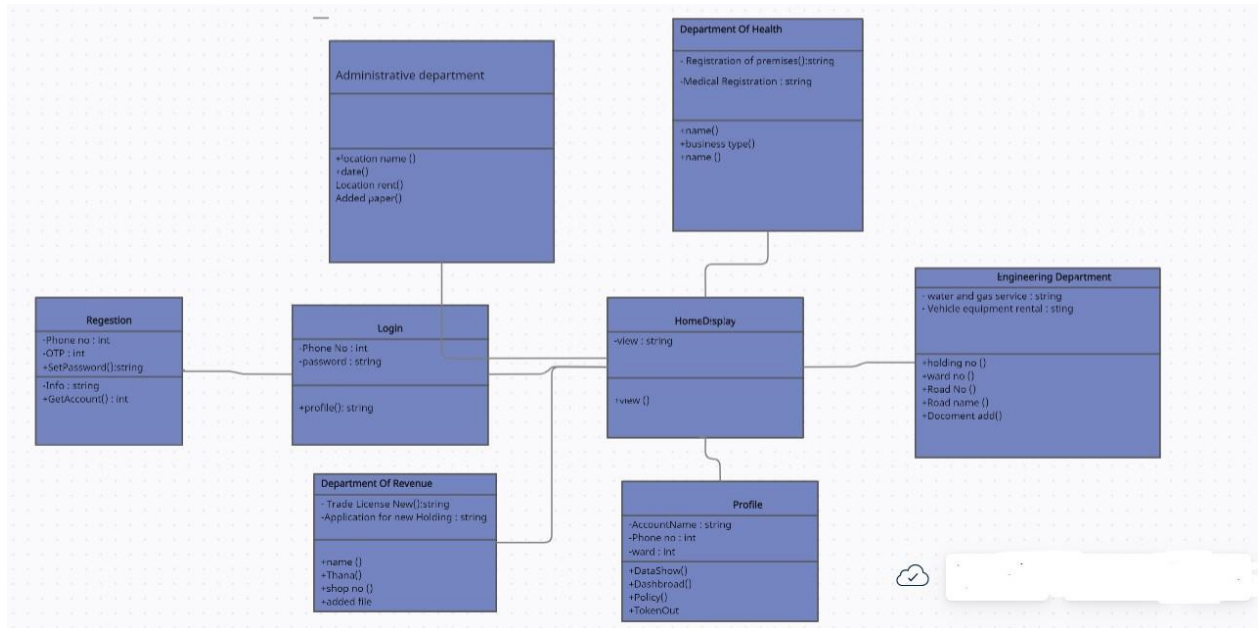

Figure 3.5: Class diagram of the System.

3.2 Table

Table 3.7.1: Admin.

Six columns make up the admin table. Id (data type int), Email (data type varchar), Password (data type varchar), and Remember token are the three (data type varchar), Id is the main key and the dates Created at and updated at are of the timestamp data type.

Figure 3.7.1 displays the current administrative data.

Field Name	Data Type	Primary Key	Default Value	Description
Id	Int.	Primary key		
Email	Varchar			
Password	Varchar			

Remember token	Varchar			
Created at	Timestamp			
Updated at	Timestamp			

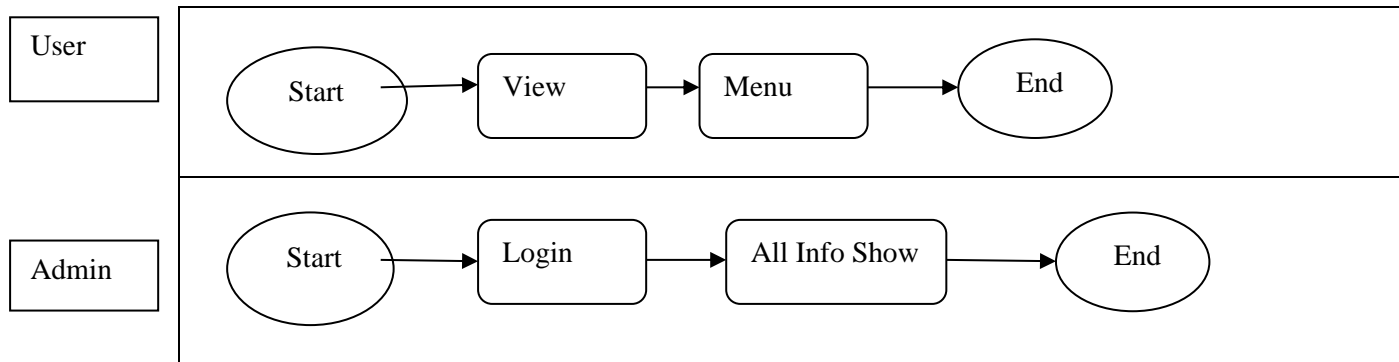

Figure 3.7.1: Admin table.

In User table, there are six columns. They are; Id (data type int), Name (data type varchar), AC (data type Varchar), Seat (data type double), Created_at (data type Timestamp) and Updated_at (data type Timestamp), where Id is primary key.

Field Name	Data Type	Primary Key	Default Value	Description
Id	Int.	Primary key		Bus identification
Name	Varchar			
AC	Varchar			
Seat	Double			
Created at	Timestamp			
Updated at	Timestamp			

3.1 Sequence Diagram

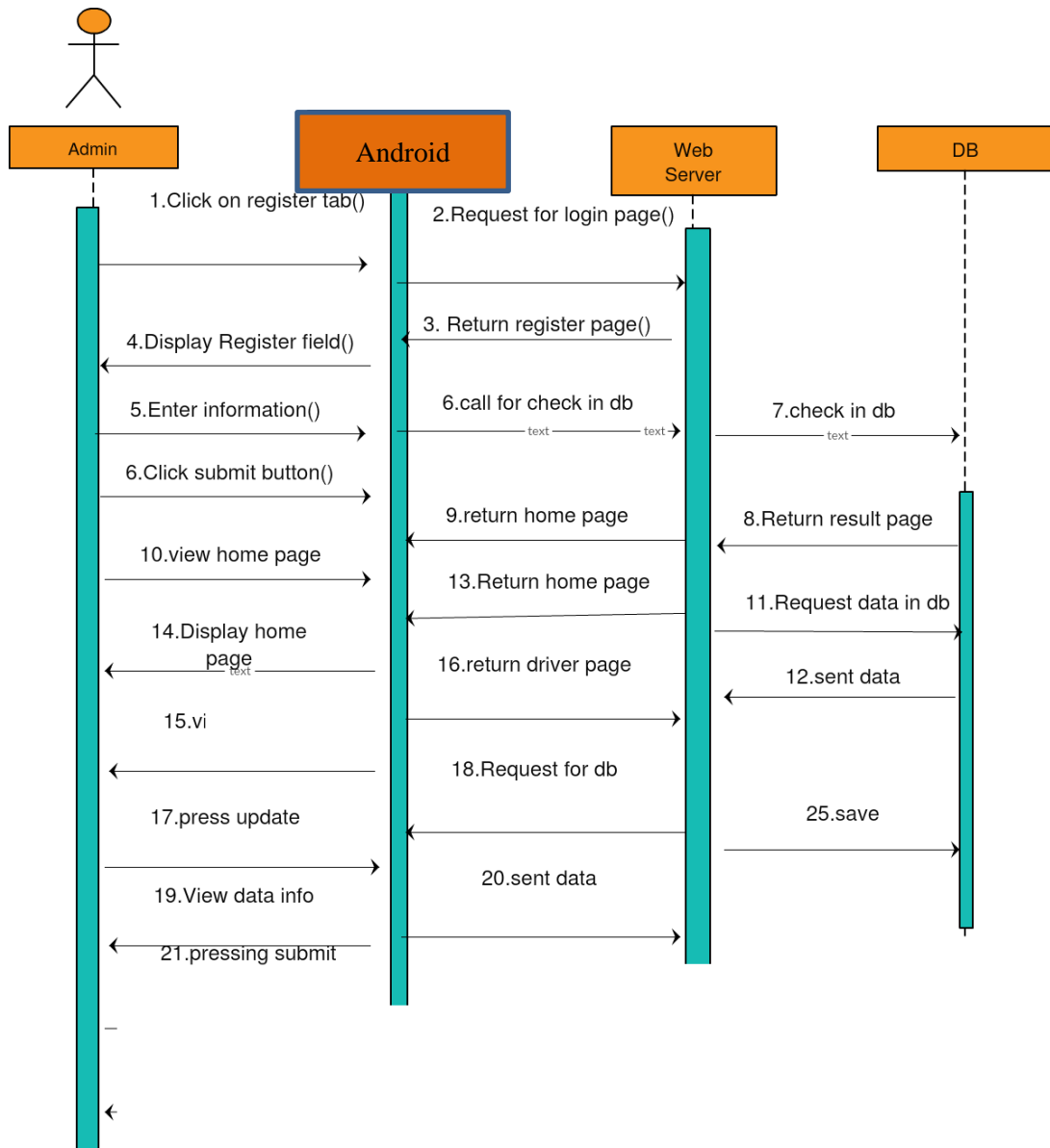

Figure 3.8.1: Sequence diagram of admin for the system.

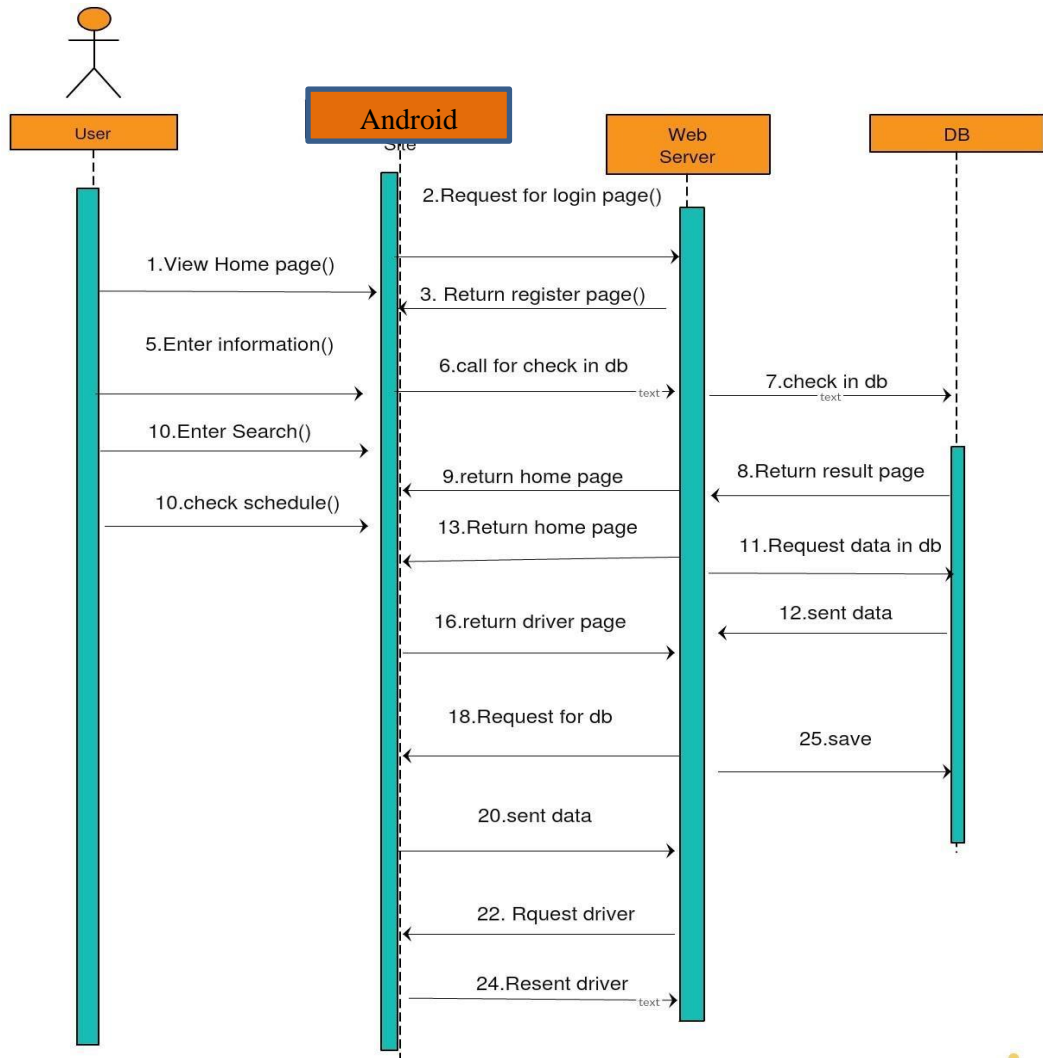

Figure 3.8.2: Sequence diagram of user for the system.

CHAPTER 4

IMPLEMENTATION AND TESTING

4.1 Implementation OF Database

In the implementation phase, the necessary hardware is installed with the DBMS, the database is optimized for that hardware and software platform, the database is built, and the data is loaded. A database might contain preexisting data that has been imported or new data that has been directly collected. During this step, you also create database security and provide the different users you've identified access that is appropriate for their needs.

4.1.1 Database Design

Mine programs' data was stored in a SQLite database. Most Android applications ought to eventually save user data. Although there are many ways to save client data, SQLite databases are a very effective and quick method for preserving client or application data.

An opensource SQL database called SQLite saves data on a device as a content document. Like Oracle, MySQL, and SQLite is a platform for managing social databases. It is possibly the most widely used database engine on the globe due to its small footprint and open area permission. It is used in a variety of programming, ranging from embedded frameworks, programs, and functioning frameworks.

4.2 Implementation of Front-end Design

The sample coding for login page, homepage, administrative page, engineering page, revenue page, medical page, notice page and logout page.

Login.dart is shown below.

The screenshot shows an IDE with the project structure on the left and the code for login_page.dart in the main editor. The file login_page.dart is highlighted in the project structure. The code defines a Container widget with padding, a Column of children, a Form widget with a key and child, a Center widget with an image asset, and another Container widget with alignment, padding, and a Text widget.

```

49 child: Container(
50   padding: const EdgeInsets.all(15),
51   child: Column(
52     children: <Widget>[
53       Form(
54         key: _formKey,
55         child: Column(
56           children: <Widget>[
57             const SizedBox(
58               height: 32,
59             ), // SizedBox
60             Center(
61               child: Image.asset(
62                 'assets/images/logo.png',
63                 width: 85,
64                 height: 85,
65               ), // Image.asset
66             ), // Center
67             Container(
68               alignment: Alignment.center,
69               padding: const EdgeInsets.all(10),
70               child: const Text(
71                 'স্বাগতম',
72                 style: TextStyle(
73                   fontSize: 24,
74                   fontWeight: FontWeight.w500,

```

Figure 4.2.1 login design code

Homepage code:

The screenshot shows an IDE with the project structure on the left and the code for home_page.dart in the main editor. The file home_page.dart is highlighted in the project structure. The code defines a Scaffold widget with a SingleChildScrollView child, a Column of children, a CustomBanner widget, a SizedBox widget, a Container widget with margin, a Row widget with children, an Expanded widget with a GestureDetector child, and a Card widget with a RoundedRectangleBorder child.

```

44 @override
45 Widget build(BuildContext context) {
46   return Scaffold(
47     body: SingleChildScrollView(
48       child: Column(children: <Widget>[
49         const CustomBanner(
50           url:
51             "https://smartrajshahi.gov.bd/media/main-banners/brand_image.jpeg",
52         ), // CustomBanner
53         const SizedBox(
54           height: 16,
55         ), // SizedBox
56         Container(
57           margin: const EdgeInsets.all(8.0),
58           child: Row(
59             children: <Widget>[
60               Expanded(
61                 child: GestureDetector(
62                   onTap: () {
63                     Get.to(const AcademicPage());
64                   },
65                 child: Card(
66                   shape: RoundedRectangleBorder(
67                     borderRadius: BorderRadius.circular(10.0),
68                   ), // RoundedRectangleBorder

```

Figure 4.2.2 home page design code

Administrative page code:

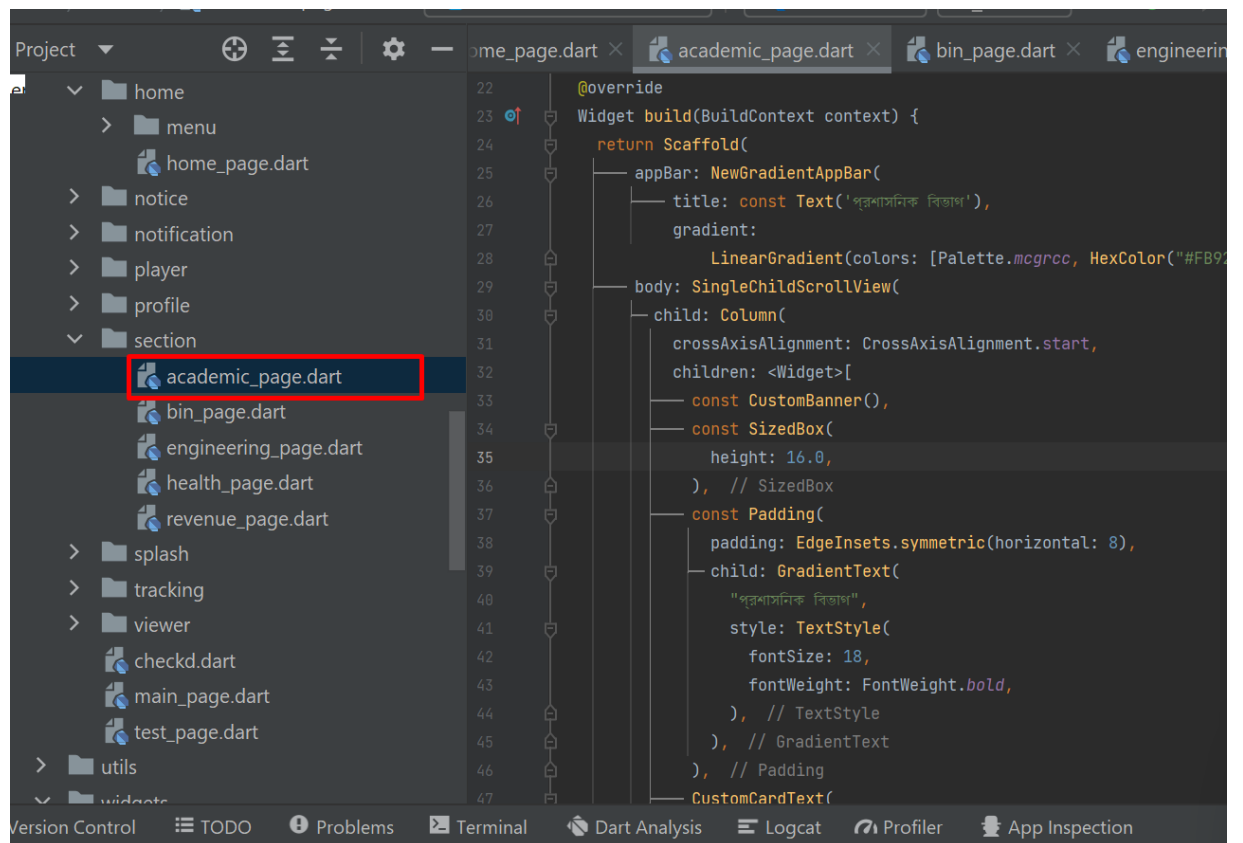

```
Project
├── home
│   └── menu
│       ├── home_page.dart
│       ├── notice
│       ├── notification
│       ├── player
│       ├── profile
│       └── section
│           ├── academic_page.dart
│           ├── bin_page.dart
│           ├── engineering_page.dart
│           ├── health_page.dart
│           └── revenue_page.dart
├── splash
├── tracking
├── viewer
│   ├── checkd.dart
│   ├── main_page.dart
│   └── test_page.dart
├── utils
└── widgets
```

```
22 @override
23 Widget build(BuildContext context) {
24   return Scaffold(
25     appBar: NewGradientAppBar(
26       title: const Text('প্ৰশাসনিক বিভাগ'),
27       gradient:
28         LinearGradient(colors: [Palette.mcgrcc, HexColor("#FB9933")],
29           begin: Alignment.topLeft,
30           end: Alignment.bottomRight),
31     body: SingleChildScrollView(
32       child: Column(
33         crossAxisAlignment: CrossAxisAlignment.start,
34         children: <Widget>[
35           const CustomBanner(),
36           const SizedBox(
37             height: 16.0,
38           ), // SizedBox
39           const Padding(
40             padding: EdgeInsets.symmetric(horizontal: 8),
41             child: GradientText(
42               "প্ৰশাসনিক বিভাগ",
43               style: TextStyle(
44                 fontSize: 18,
45                 fontWeight: FontWeight.bold,
46               ), // TextStyle
47             ), // GradientText
48           ), // Padding
49           CustomCardText(
```

Figure 4.2.3 administrative page code

Engineering page code:

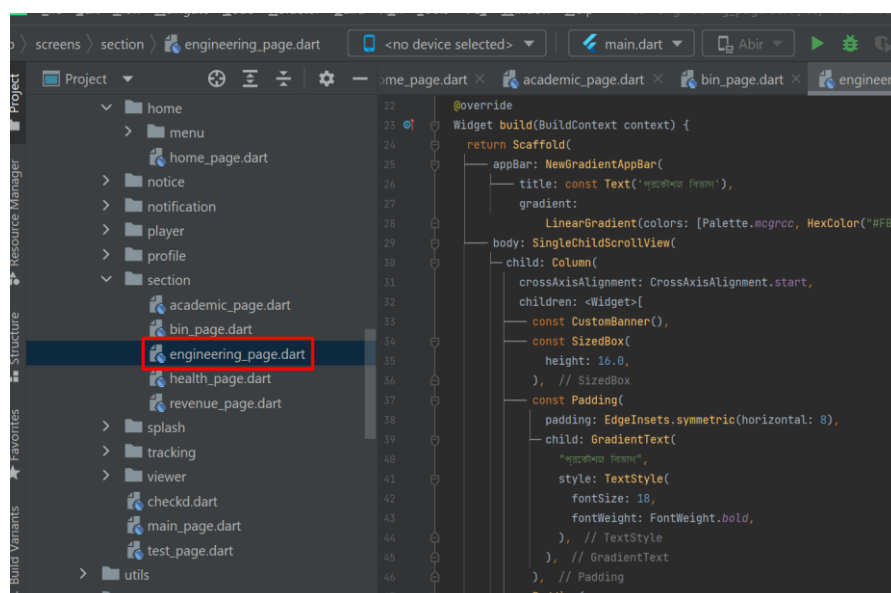

```
Project
├── home
│   └── menu
│       ├── home_page.dart
│       ├── notice
│       ├── notification
│       ├── player
│       ├── profile
│       └── section
│           ├── academic_page.dart
│           ├── bin_page.dart
│           ├── engineering_page.dart
│           ├── health_page.dart
│           └── revenue_page.dart
├── splash
├── tracking
├── viewer
│   ├── checkd.dart
│   ├── main_page.dart
│   └── test_page.dart
├── utils
└── widgets
```

```
22 @override
23 Widget build(BuildContext context) {
24   return Scaffold(
25     appBar: NewGradientAppBar(
26       title: const Text('প্ৰশাসনিক বিভাগ'),
27       gradient:
28         LinearGradient(colors: [Palette.mcgrcc, HexColor("#FB9933")],
29           begin: Alignment.topLeft,
30           end: Alignment.bottomRight),
31     body: SingleChildScrollView(
32       child: Column(
33         crossAxisAlignment: CrossAxisAlignment.start,
34         children: <Widget>[
35           const CustomBanner(),
36           const SizedBox(
37             height: 16.0,
38           ), // SizedBox
39           const Padding(
40             padding: EdgeInsets.symmetric(horizontal: 8),
41             child: GradientText(
42               "প্ৰশাসনিক বিভাগ",
43               style: TextStyle(
44                 fontSize: 18,
45                 fontWeight: FontWeight.bold,
46               ), // TextStyle
47             ), // GradientText
48           ), // Padding
49           CustomCardText(
```

Figure 4.2.4 engineering page code

Health page code:

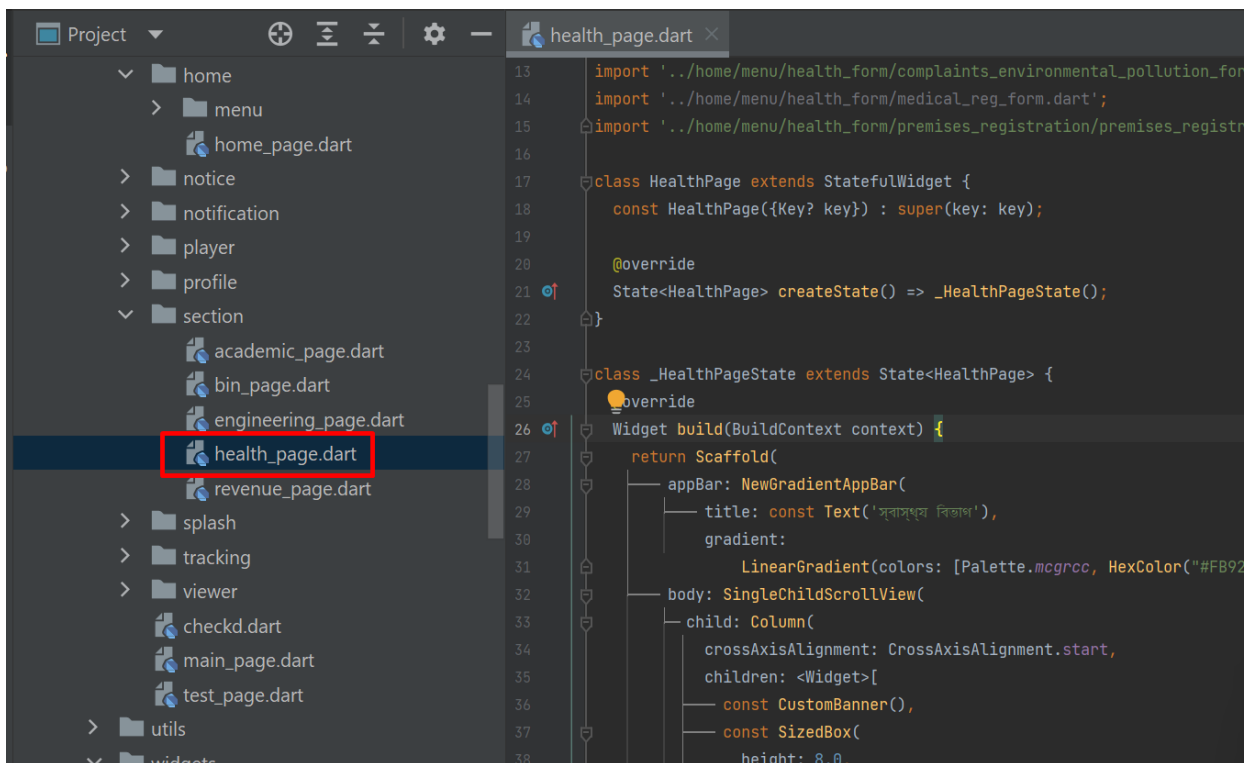

```
13 import '../home/menu/health_form/complaints_environmental_pollution_for
14 import '../home/menu/health_form/medical_reg_form.dart';
15 import '../home/menu/health_form/premises_registration/premises_registr
16
17 class HealthPage extends StatefulWidget {
18   const HealthPage({Key? key}) : super(key: key);
19
20   @override
21   State<HealthPage> createState() => _HealthPageState();
22 }
23
24 class _HealthPageState extends State<HealthPage> {
25   @override
26   Widget build(BuildContext context) {
27     return Scaffold(
28       appBar: NewGradientAppBar(
29         title: const Text('স্বাস্থ্য বিভাগ'),
30         gradient:
31           LinearGradient(colors: [Palette.mcgrcc, HexColor("#FB92
32       body: SingleChildScrollView(
33         child: Column(
34           crossAxisAlignment: CrossAxisAlignment.start,
35           children: <Widget>[
36             const CustomBanner(),
37             const SizedBox(
38               height: 8.0,
```

Figure 4.2.5 health page code

Revenue page code:

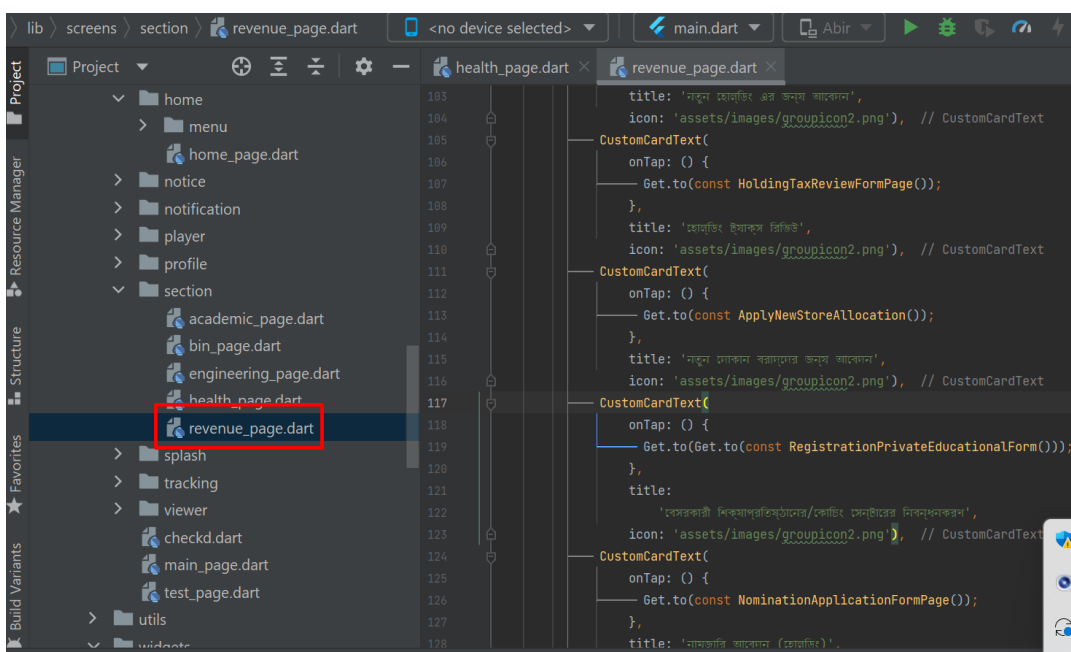

```
183 title: 'নতুন হোল্ডিং এর জন্য আবেদন',
184 icon: 'assets/images/groupicon2.png'), // CustomCardText
185 CustomCardText(
186   onTap: () {
187     Get.to(const HoldingTaxReviewFormPage());
188   },
189   title: 'সোল্ডিং ইনস্কস বিলিট',
190   icon: 'assets/images/groupicon2.png'), // CustomCardText
191 CustomCardText(
192   onTap: () {
193     Get.to(const ApplyNewStoreAllocation());
194   },
195   title: 'নতুন দোকান পরামর্শের জন্য আবেদন',
196   icon: 'assets/images/groupicon2.png'), // CustomCardText
197 CustomCardText(
198   onTap: () {
199     Get.to(Get.to(const RegistrationPrivateEducationalForm()));
200   },
201   title:
202     'বেসরকারী শিক্ষাপ্রতিষ্ঠানের/স্বাধীন চাকরির নিম্নধারকরন',
203   icon: 'assets/images/groupicon2.png'), // CustomCardText
204 CustomCardText(
205   onTap: () {
206     Get.to(const NominationApplicationFormPage());
207   },
208   title: 'নামজারি আবেদন (সোল্ডিং)',
```

Figure 4.2.6 revenue page code

Notice page code:

```

31 }
32
33 Future<void> _fetchPage(int pageKey) async {
34   try {
35     final response = await _dioClient?.get("/api/v1/notice/?page=$pageKey");
36     final newItems = NoticeResponse.fromJson(response).results!;
37     final isLastPage = newItems.length < _pageSize;
38     if (isLastPage) {
39       _pagingController.appendLastPage(newItems);
40     } else {
41       final nextPageKey = pageKey + newItems.length;
42       _pagingController.appendPage(newItems, nextPageKey);
43     }
44   } catch (error) {
45     _pagingController.error = error;
46   }
47 }
48
49 @override
50 void dispose() {
51   _pagingController.dispose();
52   super.dispose();
53 }
54
55 @override
56 Widget build(BuildContext context) {

```

Figure 4.2.7 notice page code

4.3 Overall Development System

All of the work was done in Android Studio, with Dart as the main programming language and Flutter as the framework for this project. After all of the requirements specified in the documentation have been implemented, system testing has already been completed before the entire project is published to the Android using Flutter and made available to users. After the code and database have been set up, the system is published and ready for users to utilize [15].

4.4 Testing Implementation

Table 4.1: Test Case

Test Case	Test Input	Expected Output	Actual Output	Result	Tested On
-----------	------------	-----------------	---------------	--------	-----------

1. Install Application	Tested on various Android version - Jelly Bean (4.1- 4.3.1) KitKat (4.4- 4.4.4) Lollipop (5.5-5.0.2) Marshmallow (6.0) Nougat (7.0-7.1)	Successfully Install all those versions.	Install successful.	Passed	25/11/2022
------------------------	---	--	---------------------	--------	------------

2. Upload file	Except excel and CSV file format.	To Restrict to upload the file.	Showed an error message "Upload valid format".	Passed	25/11/2022
3. notice that are ready to take update info	Click the given notice list button	Show the uploaded notice list.	Showed the list	Passed	25/11/2022
4. Delete notice	Click the delete button.	Delete notice successfully	Showed the warning.	Passed	25/11/2022
5. One tap selecting.	Check select all checkbox.	To select all user those are registered.	All checkboxes are checked.	passed	25/11/2022
6. Submit form.	Click the submit button.	To submit form.	Showed a message "Successfully submitted".	passed	25/11/2022
7. Add user.	Click Add new user button.	To add new user that are not yet registered.	Take name and phone.	passed	25/11/2022

4.5 Test Reports and Results

The testing report is required to represent testing results in a formal manner, allowing for fast estimation of testing outcomes. It is a document that organizes data acquired from an assessment experiment, describes the ambient or operational circumstances, and compares test findings to objectives. The test case, test input, expected output, actual output, and ultimately our results are found in chapter 4.4. The test result was extremely successful. Mine application has satisfied the user.

CHAPTER 5

APPLICATION DESIGN AND DESCRIPTION

The applications that are designed for the venture will be shown in this section. It is explained visually so that everyone may understand it. Graphic representation and illustration of the structure

5.1 Home

After visiting the application, the first page is application home page. Both admin and user have to visit this page, from this page user can go to any page they want and from this page admin has to registration and login to update information.



Figure 5.1: Welcome Home page

5.2 Registration page

From this page user and admin can registration to the system.

9:41

স্মার্ট রাজস্বাহী

আবেদন জমার আগে আপনার প্রোফাইলের সকল তথ্য প্রদান করুন

আপনার প্রোফাইল পিকচার সেট করুন

ছবি তুলুন

ছবি আপলোড করুন

আপডেট করুন

ফোন নাম্বার

0১৭৭২-৮৮ ৮৮ ৮৮

আপনার নাম

আপনার নাম লিখুন

পিতার নাম

আপনার পিতার নাম লিখুন

মাতার নাম

আপনার মাতার নাম লিখুন

আপনার ই-মেইল দিন

আপনার ই-মেইল এড্রেস লিখুন

আপনার জন্ম তারিখ

আপনার জন্ম তারিখ দিন

আপনার এনআইডি (NID)

আপনার এনআইডি (NID) নম্বর দিন

আপনার তিকানা

আপনার তিকানা দিন

ওয়ার্ড নম্বর

মহল্লা

আপনার ওয়ার্ড নম্বর

আপনার মহল্লার নাম

থানা

আপনার থানা

সাবমিট করুন

আপনার এনআইডি (NID) সন্মুখভাগ

ছবি তুলুন

ছবি আপলোড করুন

আপনার এনআইডি (NID) পশ্চাৎভাগ

ছবি তুলুন

ছবি আপলোড করুন

আপডেট করুন

Figure 5.2: Registration page.

5.3 Login Page

From this page user and admin can registration to the system. According to the registration phone number the user can receive a OTP. Then easily can access into the site.

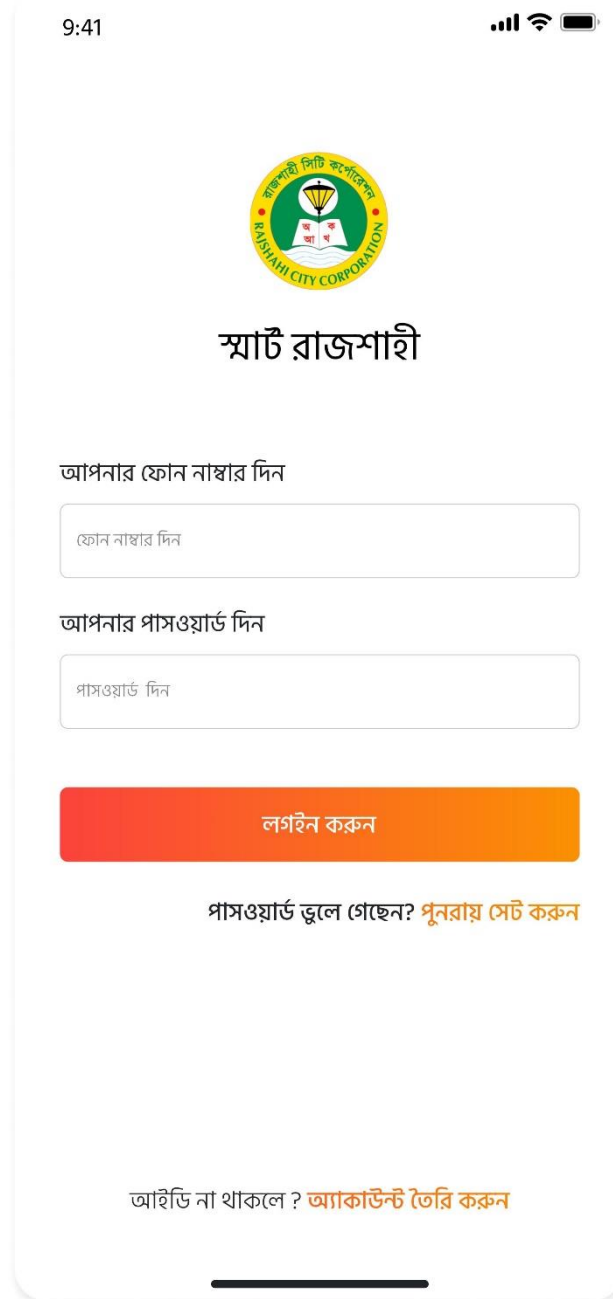

9:41

স্মার্ট রাজশাহী

আপনার ফোন নাম্বার দিন

ফোন নাম্বার দিন

আপনার পাসওয়ার্ড দিন

পাসওয়ার্ড দিন

লগইন করুন

পাসওয়ার্ড ভুলে গেছেন? [পুনরায় সেট করুন](#)

আইডি না থাকলে? [অ্যাকাউন্ট তৈরি করুন](#)

Figure 4.3: Login Page

5.4 User Profile

After log in user can view the profile page. Here user can edit some settings.

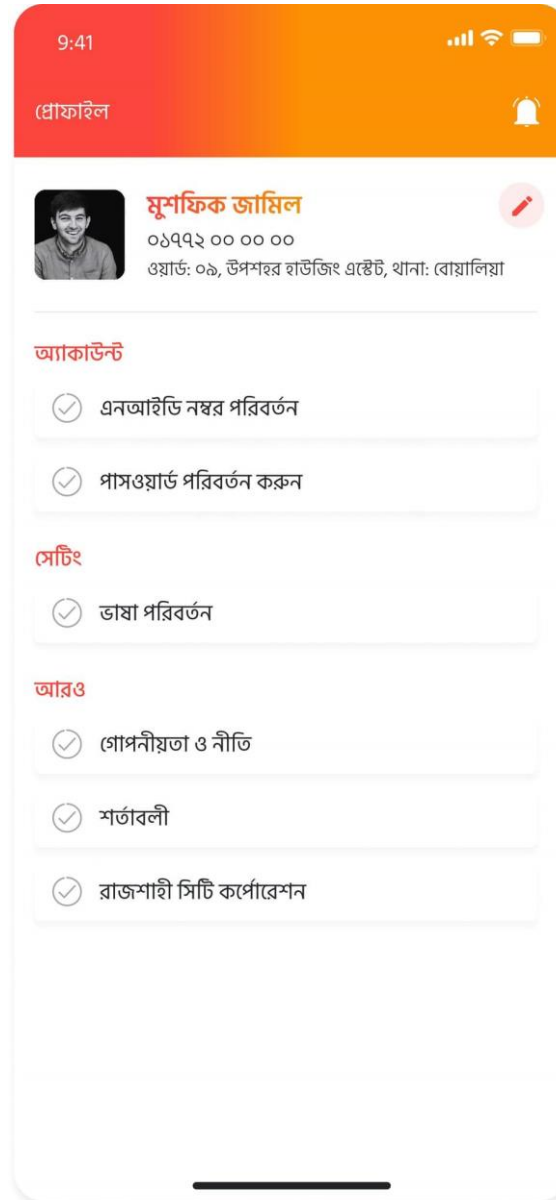

Figure 4.4 User Profile page.

5.5 Department's list

Admin and user can view the city departments list where city provided the services.

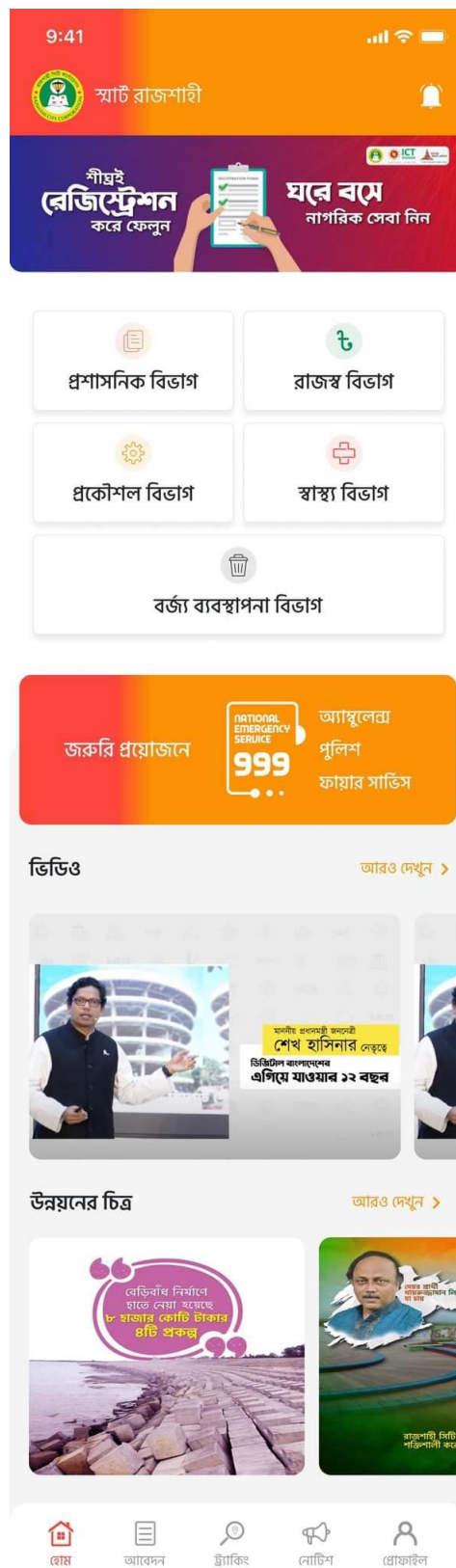

Figure 4.5: Department's list

5.6 Administrative Department

In this page viewer can view the administrative department's services. Any services can edit, update by Admin and any kind of form or message can submit by the user

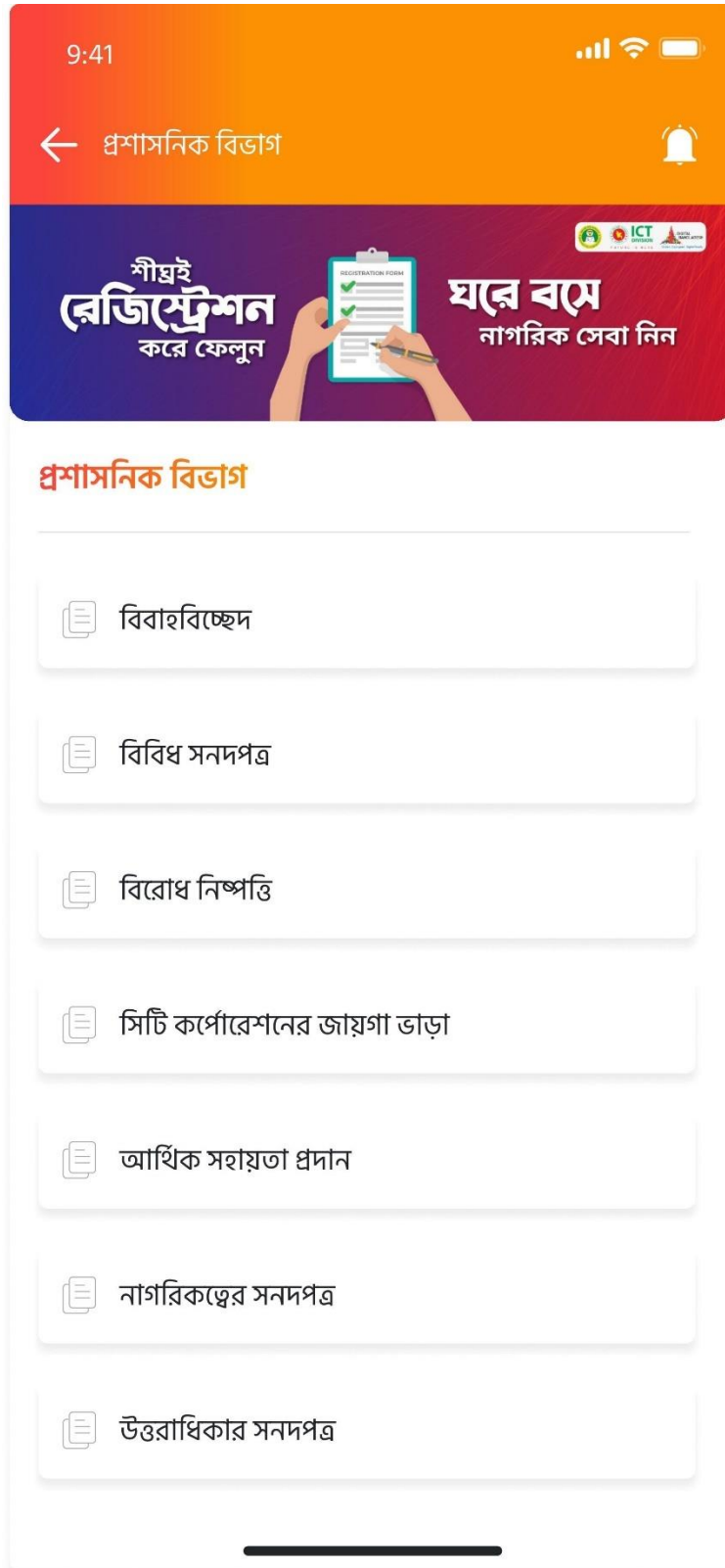

Figure 4.6: Administrative Department

5.7 Engineering Department

This page viewer can view the engineering department's services. Any services can edit, update by admin and any kind of form or message can submit by the user.

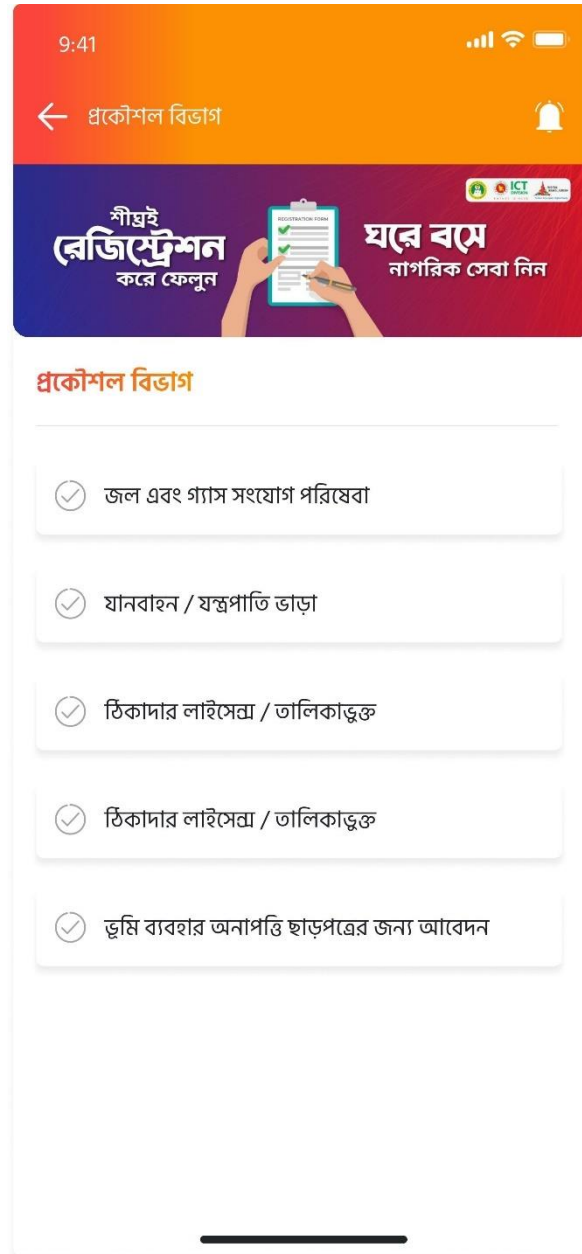

Figure 4.7: Engineering Department

5.8 Revenue Department

This page viewer can view the revenue department's services. Any services can edit, update by admin and any kind of form or message can submit by the user.

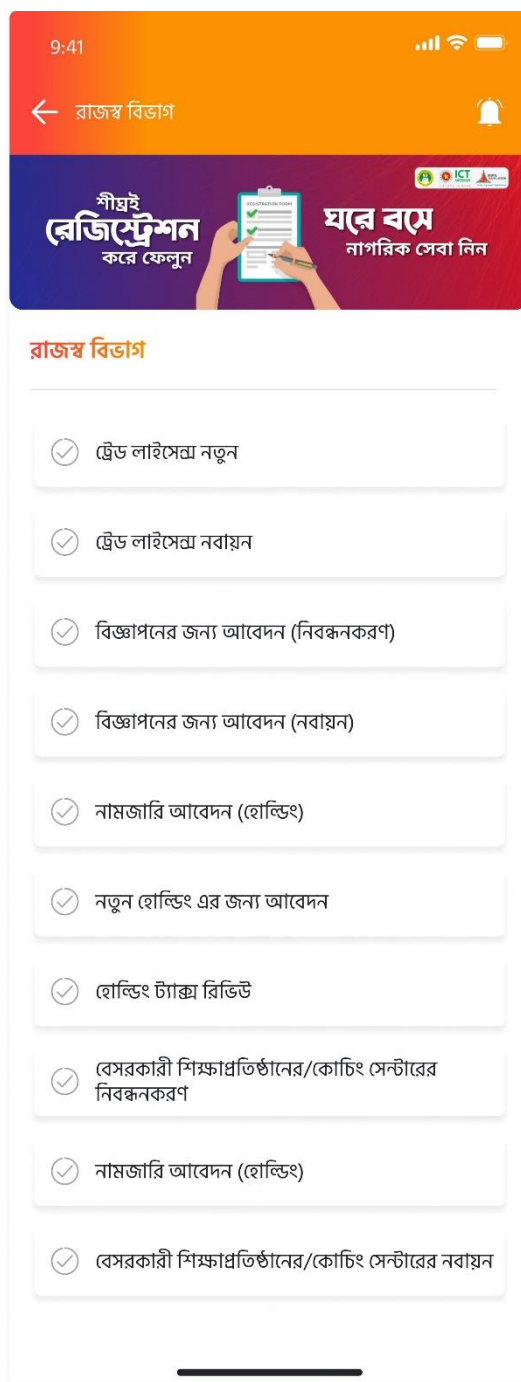

Figure 4.8: Revenue Department

5.9 Health Department

In this page viewer can view the health department's services. Any services can edit, update by Admin and any kind of form or message can submit by the user.

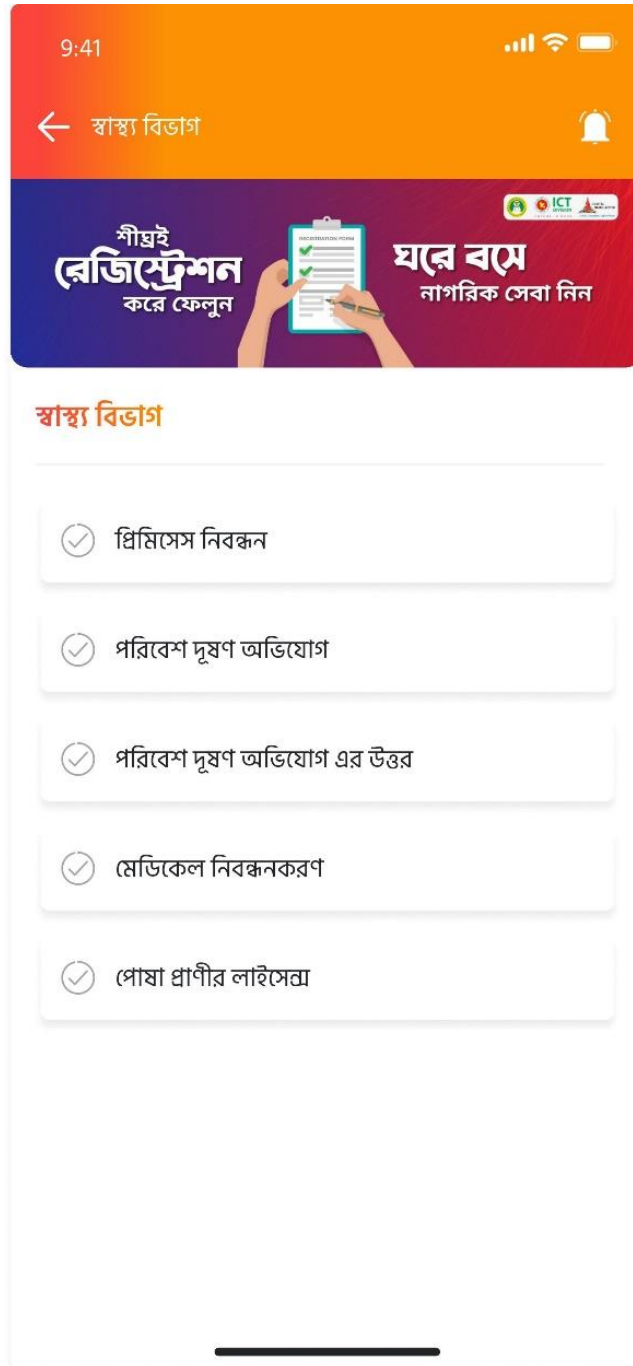

Figure 4.9: Health Department

5.10 Waste Management Department

In this page viewer can view the administrative department's services. Any services can edit, update by Admin and any kind of form or message can submit by the user.

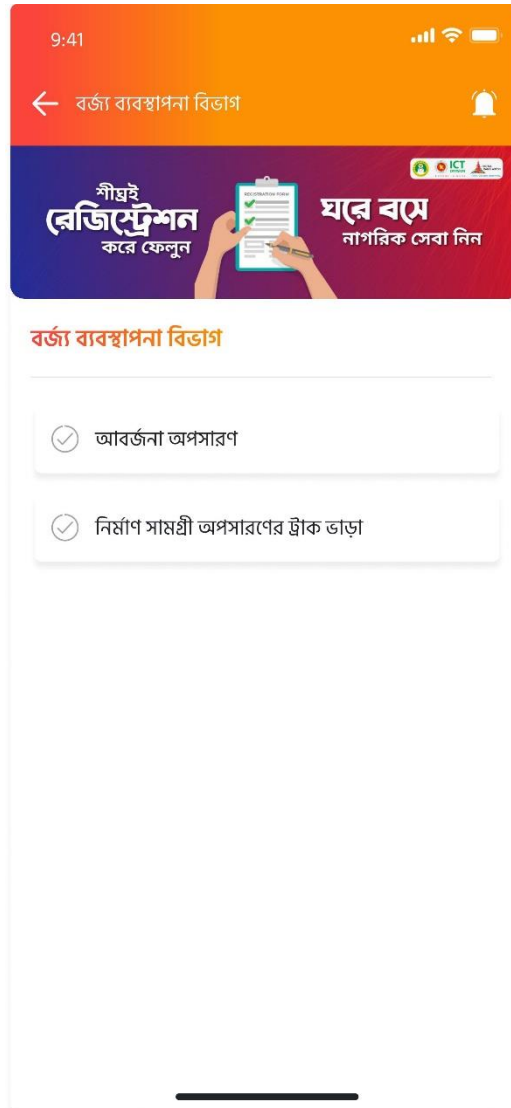

Figure 4.10: Waste Management Department

5.11 Notice Page

This page views the whole notice what submitted by the Admin of the City corporation.

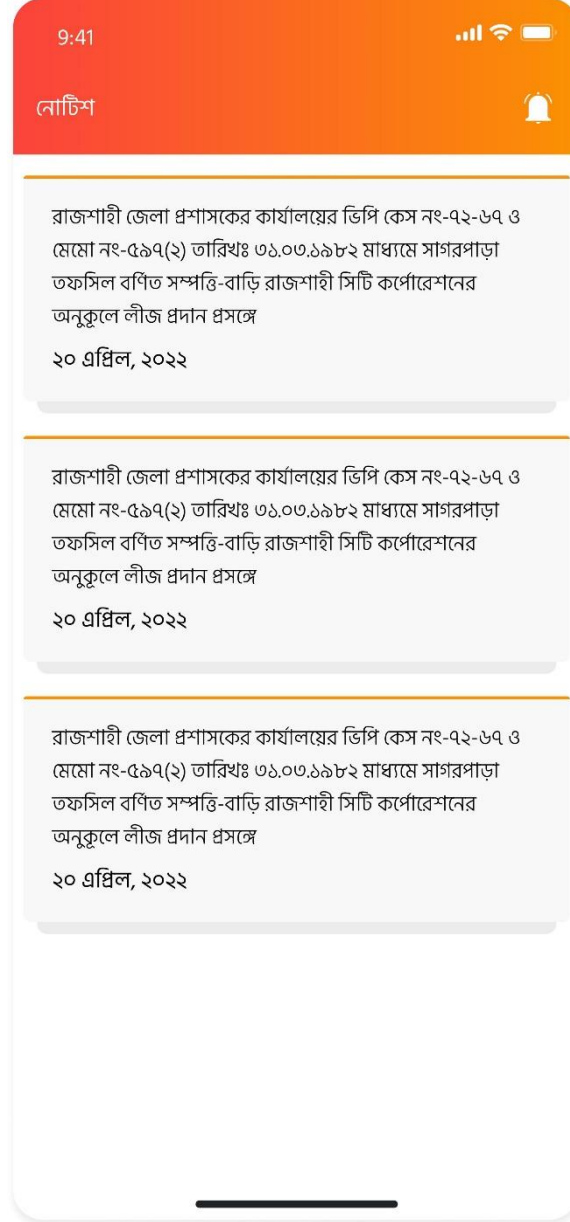

Figure 4.11: Notice Page

CHAPTER 6

CONCLUSION AND FUTURE SCOPE

6.1 Discussion and Conclusion

A mobile application based on Android has been successfully implemented. I tested it with several devices and it worked well and provided the needed info. This application's design is incredibly user friendly, so anyone with a basic understanding of smartphones may use it. I am motivated to design this type of application since I have seen similar applications in our Dhaka city. Developing smart connected systems for our city Rajshahi provides several benefits for citizens, not only for improving quality of life, but also for ensuring sustainability and the most effective utilization of resources. It is beneficial to Rajshahi residents. It is a useful application that saves time. Everything now depends on computer science and information technology. I'm starting this project as an Android app, and I'm hoping that people will find it useful.

6.2 Limitations

My application has some limitations. I'll get beyond such restrictions in the future. Among the major limitations are:

- I only developed for android version.
- Security challenges in smart Rajshahi apps.

6.3 Scope for Future Developments

- I'll attempt to create this application for all platforms in the future.
- I'll plan to implement data mining so that students may grow by taking lessons from earlier experiences.
- To improve user engagement, I will create the UI design.
- In order to serve larger enterprises, I'll add more features to make it more dynamic.

References

- [1] Y. Ki and D. Lee, "A traffic accident recording and reporting model at intersections," in *IEEE Transactions on Intelligent Transportation Systems*, vol. 8, no. 2, pp. 188–194, June 2007.
- [2] A. Franklin, "The future of cctv in road monitoring," in *Proc. of IEE Seminar on CCTV and Road Surveillance*, May 1999, pp. 10/1–10/4.
- [3] F. Baselice, G. Ferraioli, G. Matuozzo, V. Pascazio, and G. Schirinzi, "3d automotive imaging radar for transportation systems monitoring," in *Proc. of IEEE Workshop on Environmental, Energy, and Structural Monitoring Systems*, Sep 2014, pp. 1–5.
- [4] Y. Ki, J. Choi, H. Joun, G. Ahn, and K. Cho, "Real-time estimation of travel speed using urban traffic information system and cctv," in *Proc. of International Conference on Systems, Signals and Image Processing (IWSSIP)*, May 2017, pp. 1–5.
- [5] R. J. Blissett, C. Stennett, and R. M. Day, "Digital cctv processing in traffic management," in *Proc. of IEE Colloquium on Electronics in Managing the Demand for Road Capacity*, Nov 1993, pp. 12/1–12/5.
- [6] "Road safety facts," <https://www.asirt.org/safe-travel/road-safety-facts/>. [7] W. Hu, X. Xiao, D. Xie, T. Tan, and S. Maybank, "Traffic accident prediction using 3-d model-based vehicle tracking," in *IEEE Transactions on Vehicular Technology*, vol. 53, no. 6, pp. 677–694, May 2004.
- [8] K. He, G. Gkioxari, P. Dollr, and R. Girshick, "Mask r-cnn," in *Proc. of IEEE International Conference on Computer Vision (ICCV)*, Oct 2017, pp. 2980–2988.
- [9] T. Lin, M. Maire, S. J. Belongie, L. D. Bourdev, R. B. Girshick, J. Hays, P. Perona, D. Ramanan, P. Dollár, and C. L. Zitnick, "Microsoft COCO: common objects in context," in *CoRR*, vol. abs/1405.0312, 2014. [Online]. Available: <http://arxiv.org/abs/1405.0312>
- [10] D. Singh and C. K. Mohan, "Deep spatio-temporal representation for detection of road accidents using stacked autoencoder," in *IEEE Transactions on Intelligent Transportation Systems*, vol. 20, no. 3, pp. 879–887, March 2019.
- [11] Z. Hui, X. Yaohua, M. Lu, and F. Jiansheng, "Vision-based real-time traffic accident detection," in *Proc. of World Congress on Intelligent Control and Automation*, June 2014, pp. 1035–1038.
- [12] Y. Ki and D. Lee, "A traffic accident recording and reporting model at intersections," in *IEEE Transactions on Intelligent Transportation Systems*, vol. 8, no. 2, pp. 188–194, June 2007.
- [13] "Object detection for dummies part 3: R-cnn family," <https://lilianweng.github.io/lil-log/assets/images/rcnn-family-summary.png>.
- [14] Z. Hui, X. Yaohua, M. Lu, and F. Jiansheng, "Vision-based real-time traffic accident detection," in *Proc. of World Congress on Intelligent Control and Automation*, June 2014, pp. 1035–1038.
- [15] D. Singh and C. K. Mohan, "Deep spatio-temporal representation for detection of road accidents using stacked autoencoder," in *IEEE Transactions on Intelligent Transportation Systems*, vol. 20, no. 3, pp. 879–887, March 2019.

Smart Rajshahi: A Cross-platform Application

ORIGINALITY REPORT

16%

SIMILARITY INDEX

14%

INTERNET SOURCES

0%

PUBLICATIONS

4%

STUDENT PAPERS

PRIMARY SOURCES

1	dspace.daffodilvarsity.edu.bd:8080 Internet Source	11%
2	Submitted to University of Strathclyde Student Paper	3%
3	www.talentedladiesclub.com Internet Source	<1%
4	Submitted to University of Wales, Lampeter Student Paper	<1%
5	Henry Li. "Introduction to Windows Azure", Springer Science and Business Media LLC, 2009 Publication	<1%
6	Submitted to Universiti Teknologi Malaysia Student Paper	<1%
7	Submitted to CSU, San Jose State University Student Paper	<1%

Exclude bibliography On