

**Daffodil International University**  
*Department of Electrical & Electronic Engineering*



**Design of an Uninterruptible Power Supply  
(UPS)**

**Supervised by**

**Kazi Taufiqur Rahman**

**Lecturer**

Department of Electrical & Electronic Engineering

Daffodil International University

Dhaka-1207, Bangladesh

**Submitted by**

**Md. Hafizur Rahman**

ID: 103-33-370

**Md.Habibur Rahman**

ID: 103-33-377

A project submitted to the department of Electrical & Electronic Engineering, Daffodil International University, Dhaka, in partial fulfillment of the requirement for the degree of  
**“Bachelor of Science in Electrical & Electronic Engineering”**.

## DECLARATION

We hereby declare that, this project has been done under the supervision of Kazi Taufiqur Rahman, Lecturer, Department of EEE, Daffodil International University. We also declare that neither this project nor any part of this project has been submitted elsewhere for award of any degree or diploma.

**Supervisor**  
**Kazi Taufiqur Rahman**  
Lecturer,  
Dept. of EEE  
Daffodil International University

**Md. Hafizur Rahman**  
**ID: 103-33-370**

**Md.Habibur Rahman**  
**ID: 103-33-377**

## ACKNOWLEDGEMENT

First we express our heartiest thanks and gratefulness to almighty Allah for his diving blessing makes us possible to complete this project successfully.

We feel grateful to and wish our profound our indebtedness to Supervisor **Kazi Taufiqur Rahman**, Department of EEE, Daffodil International University, and **Md. Jewel Rana**, Lecturer, Department of EEE, Daffodil International University, Dhaka. Deep Knowledge & keen interest of our supervisor in the field of electric power influenced us to carry out this project. His endless patience, scholarly guidness, continual encouragement, constant and energetic supervision, constructive criticism, vaiuable advice at all stage made it possible to complete this project.

We would like to thank our entire course mate in Daffodil International University, who took part in this discuss while completing the course work.

Finally, we must acknowledge with due respect the constant support and patients of our parents.

## ABSTRACT

Digital equipment such as computers, telecommunication systems and instruments use microprocessors that operate at high frequencies allowing them to carry out millions or even billions of operations per second. A disturbance in the electrical supply lasting just a few milliseconds can affect thousands or millions of basic operations. The result may be malfunctioning and loss of data with dangerous or costly consequences (e.g. loss of production). That is why many loads, called sensitive or critical loads, require a supply that is protected. Many manufacturers of sensitive equipment specify very strict tolerances, much stricter than those in the distribution system for the supply of their equipment, one example being Computer Business Equipment Manufacturer's Association for computer equipment against distribution system disturbances. The design of this uninterrupted power supply (UPS) for personal computer (PC) is necessitated due to a need for enhanced portability in the design of personal computer desktop workstations. Apart from its original functionality as a backup source of power, this design incorporates the unit within the system unit casing, thereby reducing the number of system components available. Also, the embedding of this unit removes the untidiness of connecting wires and makes the whole computer act like a laptop. Not to be left out is the choice of a microcontroller as an important part of the circuitry. This has eliminated the weight and space-consuming components that make up an original design. The singular use of this microcontroller places the UPS under the class of an advanced technology device.

# CONTENTS

<b>Chapter 1</b>	<b>Introduction</b>	<b>1-6</b>
1.1	Introduction	2
1.2	Why is a UPS Needed?	
	1.2.1 Power Problems	3
	1.2.2 Spikes	3
	1.2.3 Electrical Noise	4
	1.2.4 Surges	4
	1.2.5 Sags	4
	1.2.6 Harmonics	4
	1.2.7 Brownouts	5
	1.2.8 Blackouts	5
1.3	Critical Load Applications	5
1.4	Summary	5
<b>Chapter 2</b>	<b>Fundamentals of UPS</b>	<b>7-12</b>
2.1	UPS Rating	8
2.2	VA and Watts	8
2.3	Power Factor (pf)	9
2.4	Types of UPS	10
	2.4.1 'Micro' Systems – up to 250VA	10
	2.4.2 Mini-Systems – 500-2000 VA	10
	2.4.3 Medium-Sized Systems – 3-20kVA	11
	2.4.4 High-Power Systems (typically 30-400kVA)	11
2.5	Summary of UPS types	12
2.6	Use of UPS types in the industry	12
<b>Chapter 3</b>	<b>System Description</b>	<b>13-17</b>
3.1	Construction of UPS	14
3.2	The UPS Solution	15
3.3	System Concept	15

<b>Chapter 4</b>	<b>UPS Control</b>	<b>18-23</b>
4.1	Control Techniques	19
	4.1.1 Battery Charger Control	19
	4.1.2 Power Factor Correction Control	20
	4.1.3 Dc/dc Step-Up Converter Control	21
	4.1.4 Output Inverter Control	22
<b>Chapter 5</b>	<b>Hardware Design</b>	<b>24-35</b>
5.1	Uninterruptible Power Supply (UPS): Basic Circuit Diagram	25
5.2	Design criteria and selection	26
5.3	Bypass mode	28
5.4	Single-phase SCR characteristics	31
5.5	Effects of loads on static UPS systems	34
<b>Chapter 6</b>	<b>Conclusion</b>	<b>36-37</b>
6.1	Conclusions	36
<b>References</b>		<b>38</b>

## **Chapter 1**

# **INTRODUCTION**

## 1.1 Introduction

An uninterruptible power supply, commonly called a UPS is a device that has the ability to convert and control direct current (DC) energy to alternating current (AC) energy. It uses a conventional battery of 12V rating as the input source and by the action of the inverter circuitry; it produces an alternating voltage which is sent to the load. This particular UPS is designed for a small scale load like a personal computer and hence only a basic power rate is generated by the UPS. Many believe that because an inverter is operating from a nominal 12V battery and it cannot deliver as much output as a normal mains power outlet, it's relatively safe. This is not usually true. Even a low power inverter rated at a mere 60watts has an output which is potentially fatal if you become its load. Such an inverter can have a typical output of 350mA at 230V. This is above ten (10) times the current level connected to cause fatal fibrillation and stop your heart.

Generally, uninterrupted power supply (UPS) can be grouped by source or method of functionality. By Source: Here we have a voltage source (DC) for its operation or a current source (DC). The current source however is used for very high power consumption devices hence this design is a voltage source UPS.

Amongst others here is the single tracked and dual-tract UPS. The single-tract UPS feeds the load continuously from the rectified supply directly. This type of UPS is disadvantaged because a fault in the rectification stage leads to a complete system failure. The dual tract acts like the single tract but it has a bypass that source from the mains supply. Hence the battery is used only as backup and does not run all the time unlike the single track. This design is a dual track methodology. For an ideal UPS, basic functionality is needed Being a backup utility, a UPS must ensure that there is no break in the power supply at any point in time unless major faults like fuse cuts are experienced.

An ideal UPS must provide the battery with an adequate charge so as to maintain the optimum conversion rate to AC when needed. It must also ensure overcharge protection to prevent the battery from being damaged. All forms of surges and undesired wave forms that may emanate from inverted source voltage are to be filtered and well suited to the output level. Must be sensitive to maintain stability when the battery safe voltage is being exceeded. It must also provide an overload protection for the entire unit.

Many embedded devices provide a rich GUI-based user experience; use file systems, multiprocessing, and multi-threading; and include networking. An operating system (OS) can provide this feature to support the rapid development of application programs [1, 2]. In charging a battery of the personal computer (PC), a cheap, unattended, unregulated charger can destroy a battery by overcharging it. A temperature compensated charger is also highly recommended [3]. Thus most power supplies have a PWM controller based on the well-known TL494 [4] or equivalent chips (for instance KA7500). TL494 features two error amplifiers, but most power supplies only use one of these. A PWM controller featuring two error amplifiers is recommended in some design because one controls the output voltage and the other controls the output current.



However, after careful consideration of any existing design of the UPS and some embedded Systems, this particular design incorporated the following methodology upgrades: (1) The battery charging unit is basically handled by the micro-controller which detects in split microseconds the point at which the safe battery (voltage at which operating the battery to generate alternating voltage is not safe) is being exceeded. This causes the system to shut down in order to prevent damage to the battery. (2) Also handled by the microcontroller is the overcharge protection. The controller disengages the battery at full charge voltage. (3) Application software interfaced via the USB (Universal Serial Bus) port of the computer motherboard maintains a constant check link between the operating system and the UPS. (4) To enhance compactness, 2-pole relays and switches are used to eliminate duplication of components. (5) Very simple and readily available components are sourced making the device commercially viable.

## 1.2 Why is a UPS Needed?

### 1.2.1 Power Problems

A sudden loss of power will disrupt most business operations, it is not only total mains failures or ‘blackouts’ which can trigger devastating effects. Many electrical loads, for example computer systems, are equally susceptible to power sags, brown-outs, blackouts, power spikes and surges, noise and radio frequency interference, and supply frequency changes. Such loads are often referred to as ‘critical loads’, partly because their continuous operation is fundamental to the functioning of the business, and also because they require a more stable and reliable power source than that generally offered by the utility mains supply in order to guarantee their correct function.

### 1.2.2 Spikes

Spikes are short duration rapid voltage transitions super imposed on the mains wave for Spikes can inflict both positive and negative voltage excursions and can damage or destroy electrical/electronic components. Spikes are typically caused by thermostats or other equipment switching high electrical currents, or load switching by the power companies. Locally grounded lightning strikes are without doubt the most serious and

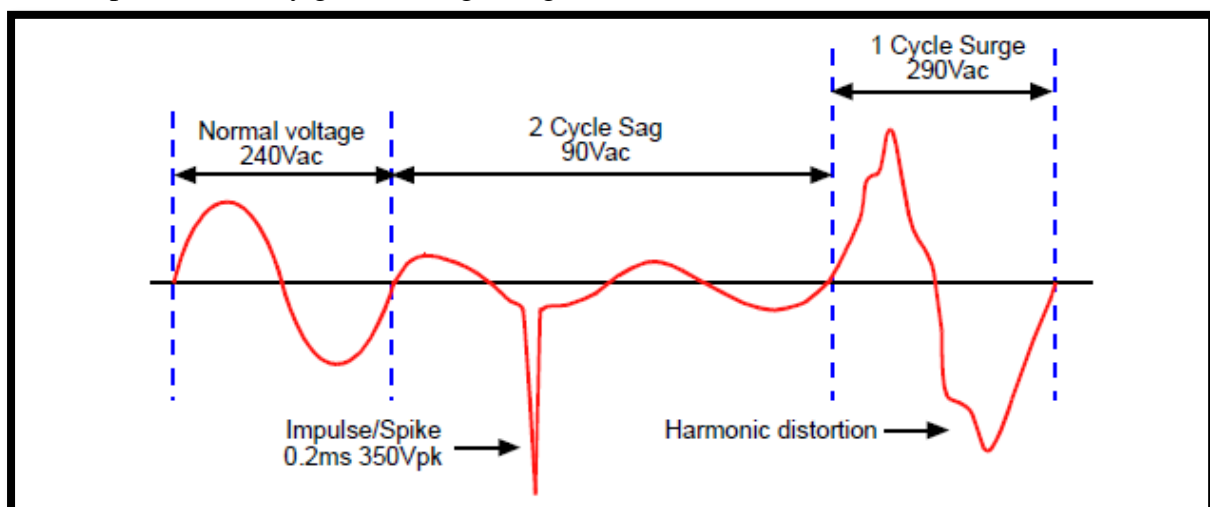

Figure 1.1: Power problems

dramatic cause of spikes, particularly when induced into telecommunications cables. Spikes can damage hardware and corrupt software. Hardware damage is an inevitable result of exposing sensitive electronic devices to high voltages. Software damage can be more costly in the long run; as periodically read files become corrupted and routine system processing may well compound the errors.

### **1.2.3 Electrical Noise**

Common Mode noise is a result of disturbances between the supply lines and earth. Normal Mode noise is the result of disturbances between line-to-line and line-to-neutral and can be caused by lightning strikes, load switching, cable faults, and nearby radio frequency equipment etc. High frequency noise energy entering the earth line can affect sensitive circuits that use the supply earth as reference for internal control logic. This type of interference is not only mains borne but can also be induced through communications cables and other external connections. It is generally minimized by fitting surge suppression filters to offending equipment and implementing proper cable screening and earthing arrangements. Electrical Noise can cause computers to 'hang' and corrupt data.

### **1.2.4 Surges**

Surges are sustained voltage increases above the normal mains value that last for more than one cycle. They typically appear after a large load is switched off or following load switching at substations. Due to their relatively long duration, voltage surges can degrade a computer's switched mode power supply components and lead to premature failure.

### **1.2.4 Sags**

Sags are drops in the mains supply that can last for several cycles. They are similar in generation to negative spikes but have a much longer duration. Sags are very common occurrences that are usually the result of switching on a large load, such as air conditioning equipment, or starting rotating machinery. Sags can cause a computer re-boot if the mains voltage falls so low that the computer believes it has been switched off.

### **1.2.5 Harmonics**

Harmonics are generally caused by non-linear loads which pull current from the mains supply in large peaks. Loads containing controlled rectifiers, switched mode power supplies, or rotating machines are particularly noted for generating this type of interference – for example computers, photocopiers, laser printers and variable-speed motors. Harmonics cause a disproportionate rise in current, resulting in increased temperatures which can cause component failure, general equipment overheating etc. Most PCs are driven by internal switched mode power supplies and the problems relating to harmonics build up progressively as the number of PCs in a building increases. In extreme cases the heat generated by the harmonics could destroy the site's main neutral bus bars unless they are significantly over-rated. Where there are a large number of computers on a site it may be necessary to employ a UPS having a low input current THD (total harmonic distortion) – e.g. less than 10%.

### **1.2.6 Brownouts**

Brownouts are identical to sags but have a much longer duration and are generally more serious. They are caused when the mains supply is unable to cope with the present load demand and the generating company drops the overall network voltage. Depending on the supply company response, brownouts could last for several hours in extreme circumstances.

### **1.2.7 Blackouts**

Blackouts are complete power losses, where the mains supply fails totally. They can be caused by supply line faults, accidents, thunderstorms and a range of other conditions. Blackouts have an obvious, sometimes devastating effect.

## **1.3 Critical Load Applications**

The numbers and types of load falling into the 'critical' category are rapidly expanding as an ever increasing range of microprocessor-based equipment enters both the industrial and commercial marketplaces. This is typified by the growth of on-line transaction processing and Ecommerce where 24 hour trading demands absolute power quality with zero downtime.

Among typical critical loads are:

- Computers – e.g. data processing and control systems.
- Industrial process equipment – e.g. precision manufacturing.
- Medical equipment – e.g. life support and monitoring systems.
- Telecommunications network equipment – e.g. PABX.
- Point of sales (POS) terminals – e.g. retailing environment.
- On-line business transactions – e.g. internet shopping.

The effects of an inadequate supply to a critical load can include:

- Cessation of the business process – i.e. a total inability to trade and/or communicate
- Data loss or corruption due to software crashing
- Expensive hardware failure including component damage – e.g. due to power sags, spikes etc.
- Production loss due to incorrect operation of a manufacturing process and possible production equipment damage
- Inappropriate control system operation
- Lost business due to failed POS or telecommunications equipment
- Possible time penalty paid to repair/reset affected systems.

## **1.4 Summary**

There is a substantial number of possible power disturbances that can affect the operation of a critical load. The one common aspect to all the disturbances described above is their total unpredictability. Any measures taken to safeguard the critical load supply must be effective at all times when the load is in use. In general, computers typically have specified upper and lower limits for steady state slow averaged rms line voltage variations of between  $\pm 5\%$  to  $\pm 10\%$ , depending on the manufacturer, but will tolerate short duration line voltage excursions outside those limits. The shorter the duration of the

excursion, the greater the excursion which can be tolerated. Some computers have sufficient energy stored in their internal power supply reservoir capacitors to sustain the dc supply to logic circuits during line voltage sags and power line interruptions of up to a 1/2 cycle (10ms), although not all units have this much ride-through capability. If the computer user is striving for less downtime and fewer errors, the electrical environment must be closely controlled.

## Chapter 2

# Fundamentals of UPS

## 2.1 UPS Rating

The power rating of electrical equipment may be stated in Watts (W) or Volt Amperes (VA) (1kVA=1000VA) but rarely both. UPS manufacturers generally use VA (or kVA) to describe the UPS output ratings, and it is this rating which determines the maximum load that can continuously be supported by the UPS when the mains supply fails. When selecting a UPS to service a particular load it is important that the combined load does not exceed the UPS output rating, and if the load equipment is specified in Watts it is necessary to convert this to VA in order to assess the UPS/load rating compatibility.

## 2.2 VA and Watts

The terms 'VA' and 'Watts' are often confused, but an understanding of the relationship between the two parameters is necessary when matching a UPS to a combination of load equipment. The VA (Volt Ampere) rating of electrical equipment is calculated by multiplying the supply Voltage (V) by the current (A) drawn from the supply – using the rms (root mean square) values of voltage and current in each case. This is illustrated in the upper diagram of Figure 5-2 which shows that a load drawing 5A from a 240V supply is rated at 1200VA (or 1.2kVA). Watts (W) are a measure of the 'real power' consumed by a load. In a dc circuit this is calculated by multiplying the supply voltage by the load current in exactly the same way as described above for VA – i.e. ( $W = A \times V$ ). In fact, in an ac circuit feeding a purely resistive (linear) load, where the supplied voltage and load current are in phase, the circuit values of VA and Watts are identical. The lower diagram in Figure 5-2 illustrates an instantaneous power waveform for a linear load and shows how the r.m.s. wattage value is obtained. In practice the load connected to an ac circuit is usually far from linear. Typical ac loads such as transformers, switched mode power supplies, motors etc. are all inductive in nature and cause the load current to lag behind the applied voltage by an amount proportional to the load's reactance.

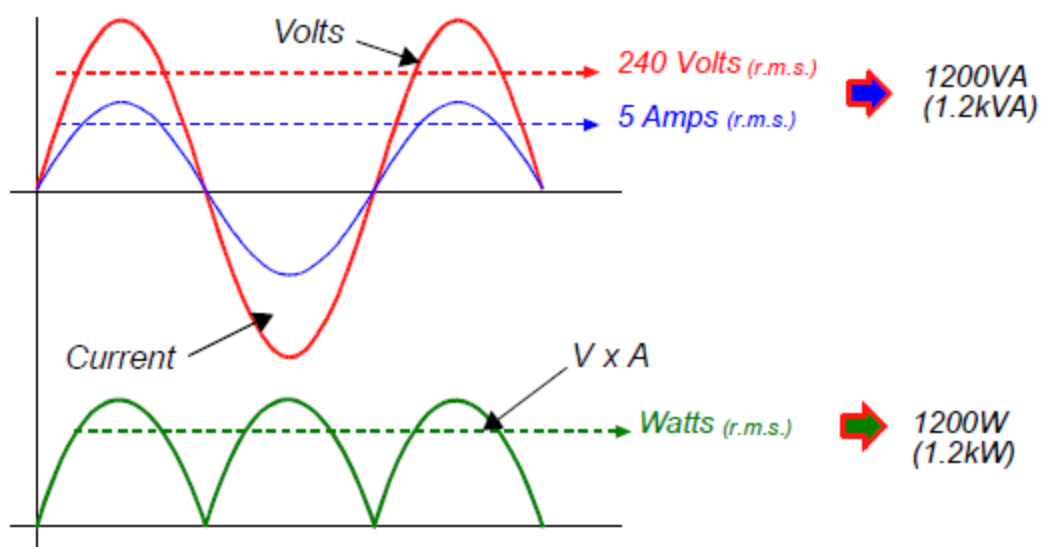

Figure 2.1: VA and Watts in a linear circuit

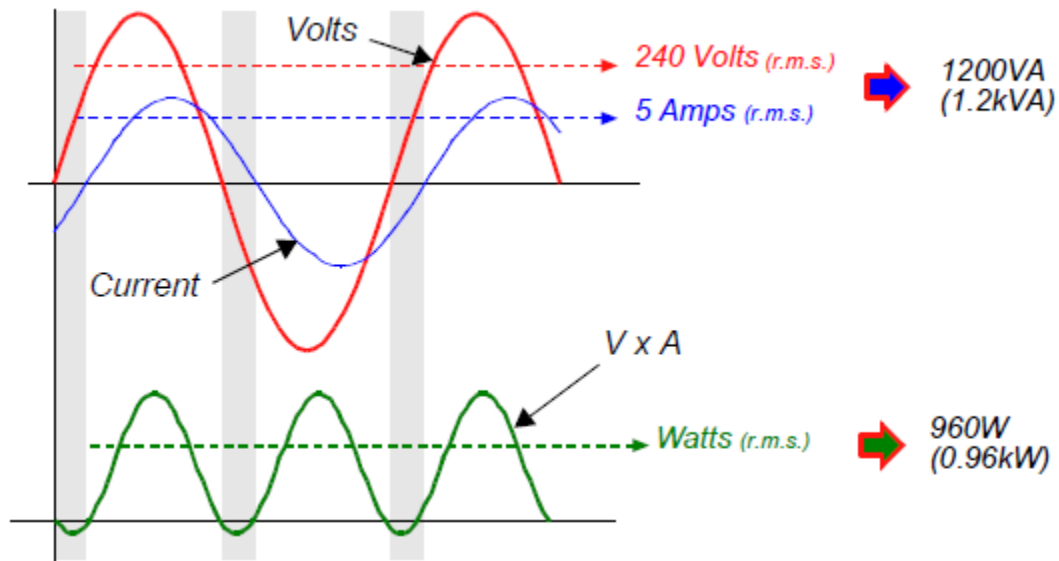

Figure 2.2: VA and Watts in a non-linear circuit

This is illustrated in where the current is shown to lag the supply voltage by approximately  $36^\circ$ . Notice that the VA rating in this example is identical to that calculated in because the rms values of the voltage and current waveforms are unaffected by the relative phase shift and the current drawn from the supply is the same in both examples. However, the lower diagram in shows a reduction in wattage rating to 960W from the previously calculated 1200W – i.e. the load is dissipating fewer Watts for the same value of VA. The reduced wattage is due to the phase relationship between the voltage and current waveforms in that the product of  $V \times A$  generates a negative value when the parameters are of different polarities. This is shown graphically in as negative excursions in the ‘Watts’ curve which occur during the shaded areas of the voltage and current waveforms.

The illustrated negative power excursions are broadly theoretical but represent ‘wasted’ power – i.e. power not dissipated usefully in the load. This is sometimes referred to as ‘reactive’ power as it is caused by, and is proportional to, the load’s reactance.

### 2.3 Power Factor (pf)

In an ac circuit the relationship between real and reactive power is known as the ‘power factor’ (pf) and is the ratio of Watts to VA. The power factor can also be determined by calculating the cosine of the phase angle between the voltage and current waveforms. For example, in Figure 3.3 where a phase angle of  $36^\circ$  was assumed, the load power dissipation (W) could be calculated as: . Clearly, if two loads of the same wattage rating but different power factors are connected to the same supply voltage the load with the higher power factor will draw less current from the supply than its partner. As mentioned at the beginning of this section, it is usual to describe a UPS in terms of its output VA (kVA) rating. If the UPS output power factor is not specified it is usual to assume a figure of 0.8. For example a 1kVA UPS would have a maximum power rating of 800W (0.8kW) and under these circumstances the total load must not exceed either of these values. Where large or highly reactive loads are concerned, measures are sometimes taken to improve the overall power factor, bringing it closer to unity. This is known as ‘power

factor correction and is generally achieved by adding a capacitive load in parallel with the load equipment to reduce the overall circuit reactance.

## **2.4 Types of UPS**

The range of UPS modules currently available is vast, beginning with ultra compact desktop units to modules of several hundred kVA. Furthermore, some manufacturers design UPS modules which can be configured as parallel-controlled multi-module systems, increasing the total system rating to several thousand kVA – e.g. 2 or 3MVA systems are possible.

### **2.4.1 ‘Micro’ Systems – up to 250VA**

Modules in this power range are typically designed to supply a single personal computer (PC) workstation and are normally housed in a mini-tower case about half the size of a typical personal computer system unit. The UPS is connected to a standard utility mains supply outlet such as a three-pin 13A socket (UK) and due to their small weight and dimensions can be considered as being portable. Modules at this power level include on-line, off-line and line interactive designs and provide a single point solution to a particular power need.

Load equipment is usually connected to a standard mains connector (IEC) on the back of the UPS which is usually protected by a circuit breaker or fuse.

At this power level the batteries are usually integral to the UPS cabinet, and extended battery cabinets are unlikely to be offered as an optional extra.

Because these modules are designed to be placed adjacent to the load equipment user it is not generally necessary to provide any remote alarm facilities to warn the operator of the module’s operational status. However, current practice might include installing an automatic control interface between the UPS and computer e.g. SMNP (Simple Network Management Protocol) or automatic shutdown software.

### **2.4.2 Mini-Systems – 500-2000 VA**

Modules in this power range are in many ways similar to the ‘micro’ UPS systems described above in that they are designed for office use and can be considered to be portable. However, the increased rating makes these modules suitable to supply a fileserver or a complete workstation comprising a PC and its peripheral equipment, such as printer (but not a laser printer), scanner etc. These modules are again connected to a standard utility mains supply outlet such as a three-pin 13A socket (UK) and can include on-line, off-line and line interactive designs.

The load equipment is usually connected to standard mains connectors (IEC) on the back of the UPS which are usually protected by a circuit breaker or fuse, but it is likely that several supply outlets are provided to facilitate the connection of several small items of load equipment. At this power level the batteries are usually integral to the UPS cabinet, but some modules might have provision to connect to additional batteries contained in a purpose built extended battery cabinet to increase the total battery back-up (autonomy) time. Where this is the case the battery charger within the module is usually sufficiently rated to provide the additional battery charging current. However, in extreme



circumstances the extended battery cabinet must include a dedicated charger system to cater for the additional batteries and will therefore also require connecting to the mains supply. As with the 'micro' UPS systems, it is not generally necessary to provide any remote alarm facilities for this size of UPS due to the close proximity of the system to the load operator. However, as with 'micro' systems, SNMP or automatic shutdown software may well be a requirement depending upon the criticality of the load.

#### **2.4.3 Medium-Sized Systems – 3-20kVA**

Modules in this power range are designed to offer more than the single point power provision afforded by the smaller desktop modules, being typically used to power a complete office network, server farm or communications centre. These modules, which cannot be considered as being portable (especially those in the upper end of the range), are permanently wired to the mains supply using medium power switchgear and may require some external input overload protection device as a standard part of the installation. The larger modules in this range may require a three-phase input supply – and indeed may even produce a three-phase output. The question of batteries varies across this particular power range. At the lower end the comments concerning the batteries fitted to the desktop systems are still valid, but when considering modules rated 15-20kVA it may well be that the batteries are housed in a separate cabinet which is positioned alongside the UPS module. In fact, most manufacturers offer a series of matching cabinets at this power level to provide a range of aesthetically appealing equipment that fits into an office environment. At the higher power levels the load equipment is either hard wired to distribution bus bars fitted within the module cabinet or the UPS output is fed to a purpose designed distribution system. At the lower end of the power range it is possible that the UPS may be fitted with standard utility power outlet sockets in the same way as the desktop models. Most modules in this power range will include facilities for remote alarms and status indications. Modules of this rating can service a major data centre but are not generally suited to an office environment due to the noise levels associated with their cooling fans and the heat generated when operating on high loads. Such modules are therefore usually located in a remote position such as a plant room, and their outputs connected to numerous loads using a dedicated mains distribution system incorporating external switchgear and protective devices.

#### **2.4.4 High-Power Systems (typically 30-400kVA)**

Modules in this power range are almost exclusively of an on-line design and invariably three phase input and output. It is unlikely that the batteries are housed within the UPS module cabinet itself, and depending on the module rating and projected autonomy time, they may be housed in a separate cabinet(s) adjacent to the UPS module or, in the case of very large systems, rack-mounted in a dedicated battery room. Some of the larger modules in this range may employ a 12-pulse rectifier to reduce the amount of mains polluting harmonics generated within the UPS entering the utility mains supply. Where a 12-pulse rectifier is used it is sometimes contained in a separate cabinet which must be positioned immediately adjacent to the main UPS cabinet, increasing the required system footprint and weight. A stand-by generator may be incorporated into the system design to

provide an alternative source of UPS input power during a utility mains failure. Such a generator must be self starting and be sufficiently large to maintain a stable output with the UPS on full load. When selecting a stand-by generator for this duty several features must be taken into account in order to ensure proper operation because the UPS input can present a hostile load to some generator systems. Due to the module's location it is usual to include a remote alarm/control panel with this type of installation, and virtually all modules in this range offer this facility as a standard feature.

## 2.5 Summary of UPS types

The following table shows some of the characteristics of the various UPS types. Some attributes of a UPS, like efficiency, are dictated by the choice of UPS type. Since implementation and manufactured quality more strongly impact characteristics such as reliability, these factors must be evaluated in addition to these design attributes.

	Practical Power Range (kVA)	Voltage Conditioning	Cost per VA	Efficiency	Inverter always operating
Standby	0 - 0.5	Low	Low	Very High	No
Line Interactive	0.5 - 5	Design Dependent	Medium	Very High	Design Dependent
Standby Ferro	3 - 15	High	High	Low - Medium	No
Double Conversion On-Line	5 - 5000	High	Medium	Low - Medium	Yes
Delta Conversion On-Line	5 - 5000	High	Medium	High	Yes

## 2.6 Use of UPS types in the industry

The current UPS industry product offering has evolved over time to include many of these designs. The different UPS types have attributes that make them more or less suitable for different applications and the APC product line reflects this diversity as shown in the table below:

	Commercial Products	Benefits	Limitations	APC's Findings
Standby	APC Back-UPS Tripp-Lite Internet Office	Low cost, high efficiency, compact	Uses battery during brownouts, Impractical over 2kVA	Best value for personal workstations
Line Interactive	APC Smart-UPS Powerware 5125	High reliability, High efficiency, Good voltage conditioning	Impractical over 5kVA	Most popular UPS type in existence due to high reliability, ideal for rack or distributed servers and/or harsh power environments
Standby Ferro	BEST Ferrups	Excellent voltage Conditioning, High reliability	Low efficiency, unstable in combination with some loads and generators	Limited application because low efficiency and instability issues are a problem, and N+1 On-Line design offers even better reliability
Double Conversion On-Line	APC Symmetra Powerware 9170	Excellent voltage conditioning, ease of paralleling	Low efficiency, Expensive under 5kVA	Well suited for N+1 designs
Delta Conversion On-Line	APC Silcon	Excellent voltage conditioning, High efficiency	Impractical under 5kVA	High efficiency reduces the substantial life-cycle cost of energy in large installations

Chapter 3

# **System Description**

### 3.1 Construction of UPS

Mainly UPS consists of the following elements as shown in block diagram:

1. Rectifier (Battery Charger)
2. Battery
3. Inverter
4. Static Switch or Contactor

**Rectifier:** As we all know that the main function of rectifier is to convert alternating input supply to D.C. which will be used to charge the battery and then fed to inverter circuit. Its output may depend upon the load requirement.

**Battery:** The storage battery is used to store energy for future use in case of main supply failure. This battery may be lead acid or any other type depends on the requirement.

**Inverter:** It does the invert process of rectifier. It converts the incoming D.C. supply to alternating power supply for the use of load. The output of inverter is sine wave. It converts D.C. to A.C. of constant frequency and amplitude. The output of Inverter may contain harmonics which can be eliminated by using external circuit or special type of inverters.

**Static Switch or Transfer Switch:** A static switch or transformer switch is required to change over the circuit that is to transfer the source of power. The operation of this time should be very fast. Generally, the switches having switching time within 10 milli seconds are used.

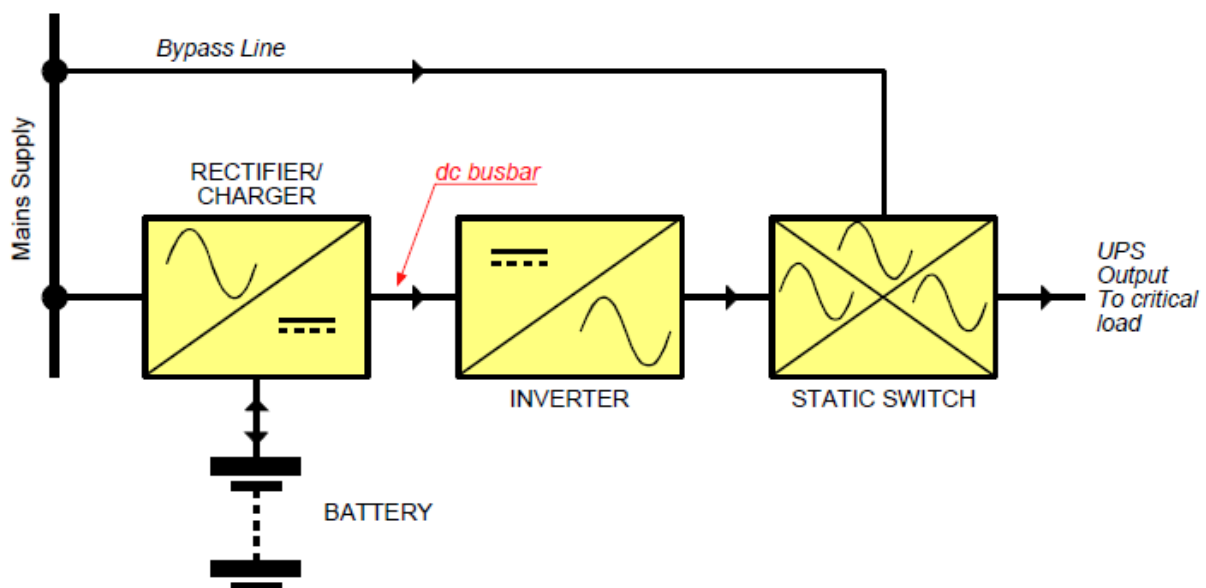
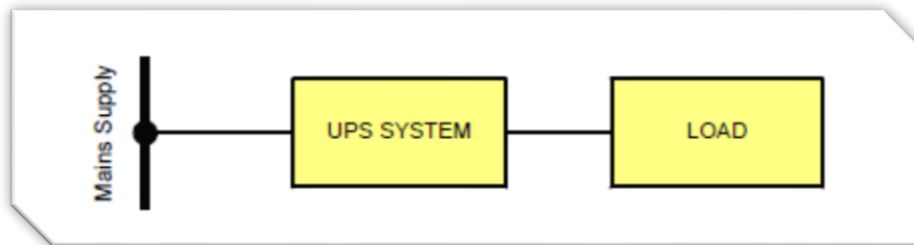

Figure 3.1: Block diagram of an UPS

### 3.2 The UPS Solution

After identifying an item of load equipment as being ‘critical’ the argument for protecting its power supply is overwhelming. However, to some extent the necessary degree of protection depends on the particular load application. For example, radio frequency noise interference and spikes can be substantially reduced by fitting suitable filters and some form of isolation transformer in the supply line. Surges also can be reduced using externally connected components. However, when considering the effects of a brownout or complete power loss, individual load requirements must be taken into account. For example a power disruption of just a few milliseconds may cause certain equipment or operations to fail completely; yet others will ride through several cycles of mains failure without harmful effects. If the load calls for a particularly close-tolerance supply, or is intended for 24-hour daily use there is no alternative but to install a form of Uninterruptible Power Supply (UPS) to provide it with continuous, processed, clean power.



*Figure 3.2: Typical UPS System Installation*

solid-state equipment which can be connected between the incoming mains supply and critical load to protect against supply aberrations including total mains failures. Because these systems are solid-state they are often described as static UPS systems, as opposed to rotary systems which are based on motor/generator technology. Rotary systems are still available, and have their uses, but in recent years they have generally been superseded for most applications by the developing static UPS technology. Therefore this chapter concentrates on static UPS systems. There are several forms of static UPS system available, employing various power topologies see However, irrespective of their category they all use a battery to provide a back-up energy store which can be called upon if the mains supply fails.

### 3.3 System Concept

The system concept of the UPS is Input consists of a rectifier (D1, D5) and a power factor correction (L1, D2, Q2). The power factor correction is controlled by a mixed approach. The dc-bus voltage control loop of PFC is controlled by the MCU. The output of the voltage controller defines the amplitude of the input current. Based on the required amplitude, the MCU generates a current reference signal. The current reference signal inputs to an external logic, which performs current controller working in hysteresis mode.

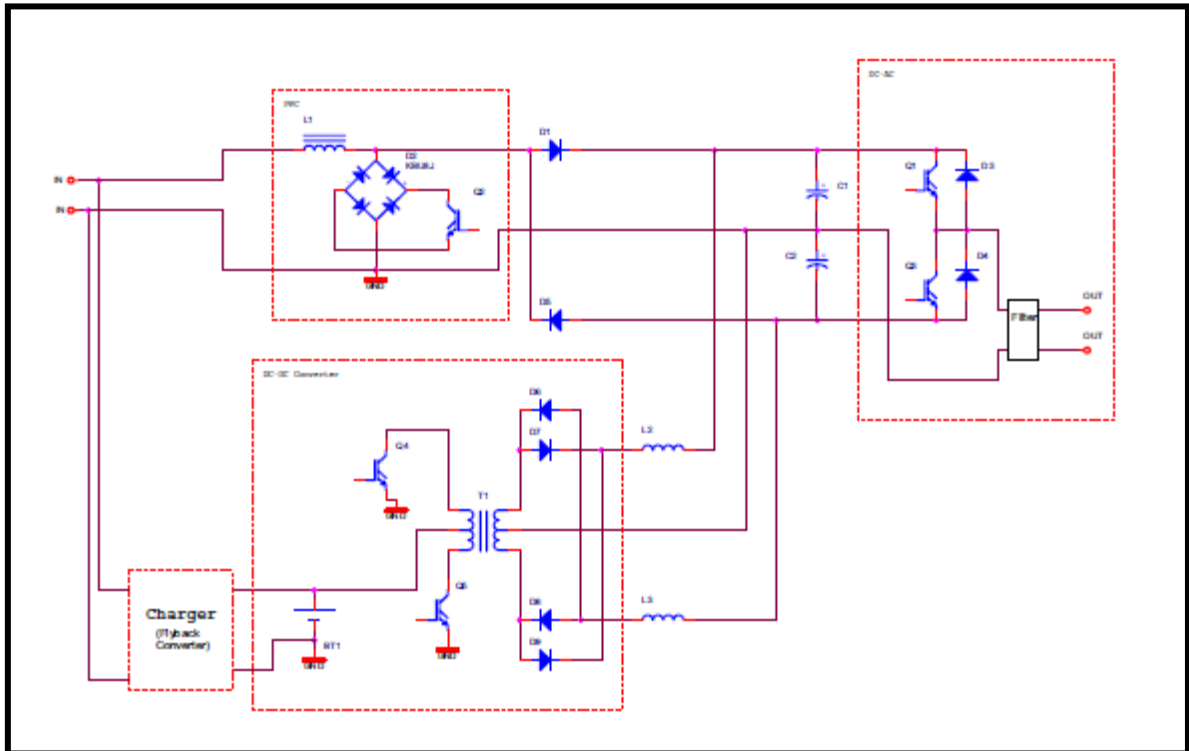

Figure 3.4: System Concept of UPS

Output is provided by an output inverter (Q1, Q3, D3, D4). The inverter converts the dc bus voltage back to a sinusoidal voltage using pulse-width modulation. The output inverter is fully controlled by the MCU and generates a pure sinusoidal waveform, free of any disturbance. The battery BT1 supplies a load during the backup mode. There are two 12-V batteries connected in serial. The battery voltage level 24-V is converted to 390-V by the dc/dc step-up converter (Q4, Q5, D6-D9, L2, L3, and T1) using a push-pull topology fully controlled by the MCU. The last part of a UPS is a battery charger. The battery charger maintains a fully charged battery. It uses a flyback topology controlled by a mixed approach. The flyback converter is controlled by a dedicated circuit and the required output voltage and current limit are set by the MCU. A dedicated circuit is used due to the lower cost compared to direct MCU control. Where a different battery charger topology is used, there is still enough MCU power to provide digital control.



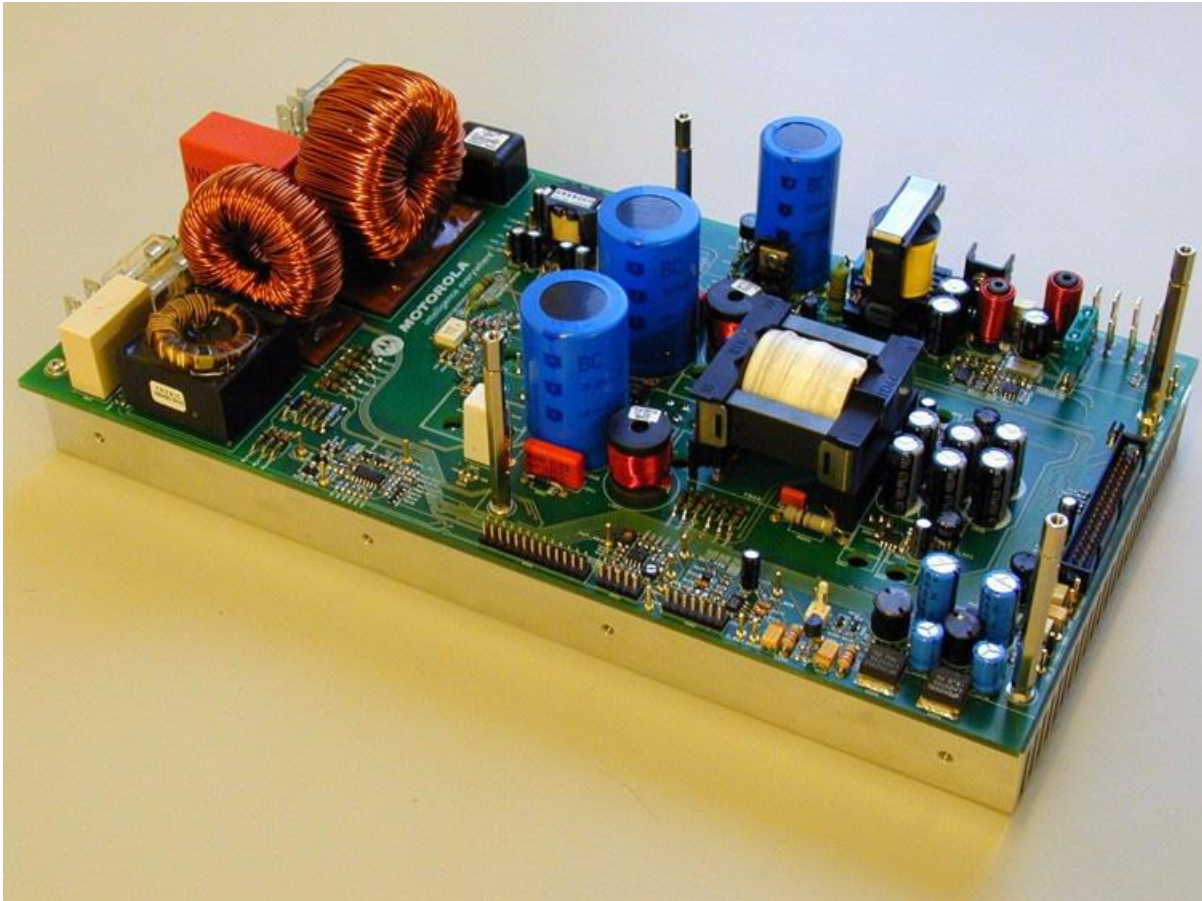

Figure 3.5: UPS Power Stage

The UPS consists of four PCBs. Most components are situated on the power stage. These are all the power components (diodes, transistors, inductors, capacitors, relay, and so on) and analog sensing circuits. The power stage is connected to the mains line (power cord for the ac line) through an input line filter, realized on the next PCB

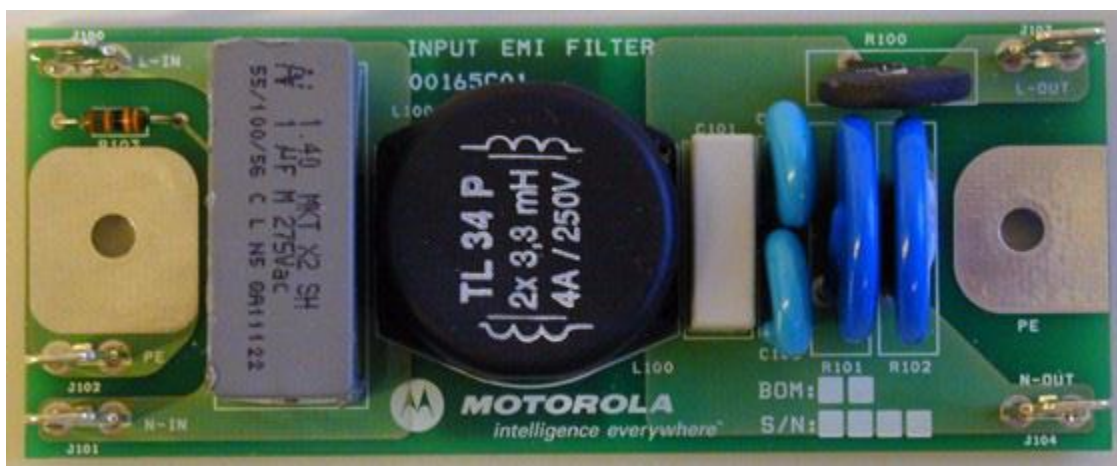

Figure 3.6: Input Filter

Chapter 4

# UPS Control



## 4.1 Control Techniques

Generally, a UPS consists of several different converters. So the control techniques differ with the converter topologies used. The presented implementation of on-line UPS includes following topologies:

- Battery charger: fly back converter (mixed control)
- PFC: boost converter (mixed control)
- Dc/dc step up converter: push-pull converter (full digital control)
- Output inverter: half bridge inverter (full digital control)

### 4.1.1 Battery Charger Control

The battery charger uses a fly back converter topology. As described Hardware Design, the fly back converter is controlled by a dedicated circuit in order to reduce cost. The interface between the fly back converter and the MCU incorporates one digital output, which allows the setting of two output voltage levels, and an analog output, which sets the current limit. Using a dedicated circuit greatly simplifies the control algorithm. The functionality of the converter itself is ensured by the dedicated circuit. Therefore, the battery charger software focuses on the charging algorithm, whose software block diagram is shown in The algorithm reads the current flowing to the batteries. The current value is compared with the maximal and float thresholds. If the value is close to the maximal value, the battery charger state is set to bulk charging and the output voltage level is set to the higher value (PU7 set to logic 1). If the actual current value is between the maximal and float thresholds, the battery charger is considered to be in the absorption state. The output voltage is still kept at a high level. As soon as the current value reaches the float threshold, the battery charger goes to the float state, and the output voltage is set to the lower level. The current limit is set during initialization, according to the number of batteries and their capacity. The control algorithm is called every 50 ms.

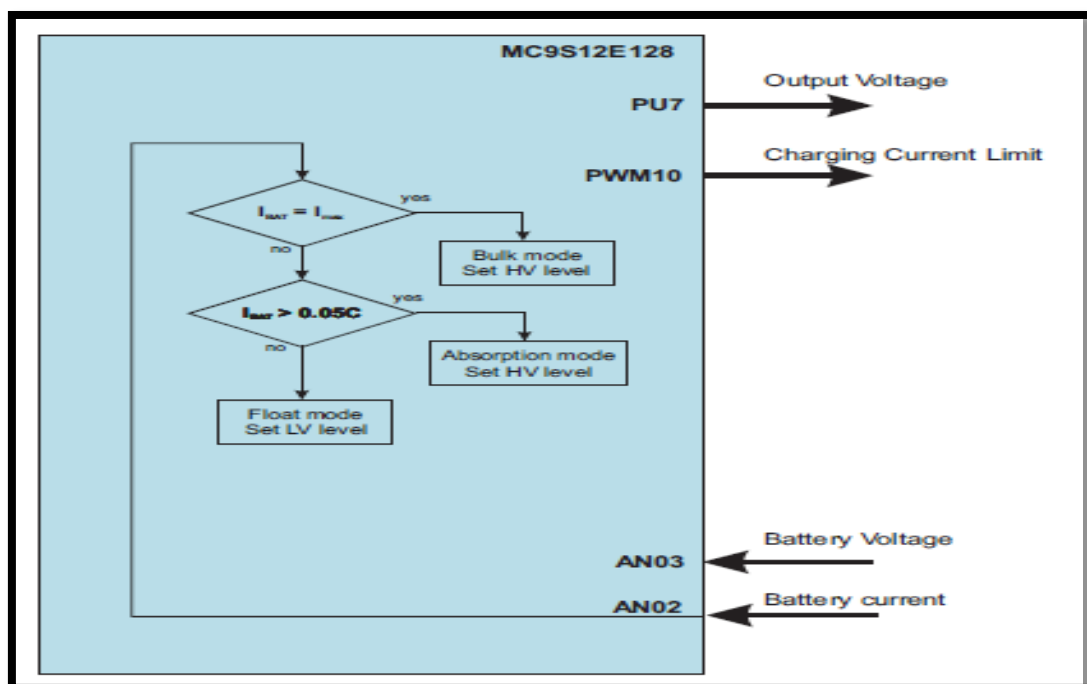

Figure 4.1: Battery Charger Algorithm

#### 4.1.2 Power Factor Correction Control

The control algorithm of the PFC is depicted in. The algorithm includes two control loops. The inner control loop maintains a sinusoidal input current. The outer loop controls the dc bus voltage. The result of the outer control loop is the desired amplitude of the input current. The current control loop is partially performed by an external circuit. This control technique is also called “indirect PFC control”. The external circuit compares the actual input current with a sine wave reference. If the actual current crosses the lower border of sine waveform, the PFC transistor is switched on. As soon as the input current reaches the upper border, the PFC transistor is switched off. The resulting input current can be seen in. Maximal switching frequency (50 kHz) corresponds to the hysteresis defined by resistors R664 and R675.

The software part of the current loop generates the sine wave reference. The sine wave reference is synchronized to be in phase with the input voltage. The sine wave generator is calculated every 50. The sine waveform is generated directly by the D/A converter within the range of the voltage reference.

The voltage control loop is fully implemented by software. The sensed dc bus voltage is compared with the required dc bus voltage, 390 V. The difference inputs to the PI controller. The PI controller output directly defines the amplitude of the input current. The PI controller constants were experimentally tuned to get an aperiodic responds to the input step. The constants are  $P = 100$  and  $TI = 0.016$  s. The voltage control loop is calculated every 1 ms. The two hardware faults are immediately able to disable the PWM outputs in case of a dc bus over voltage. The digital output, PU8, enables/disables the external logic providing the current loop.

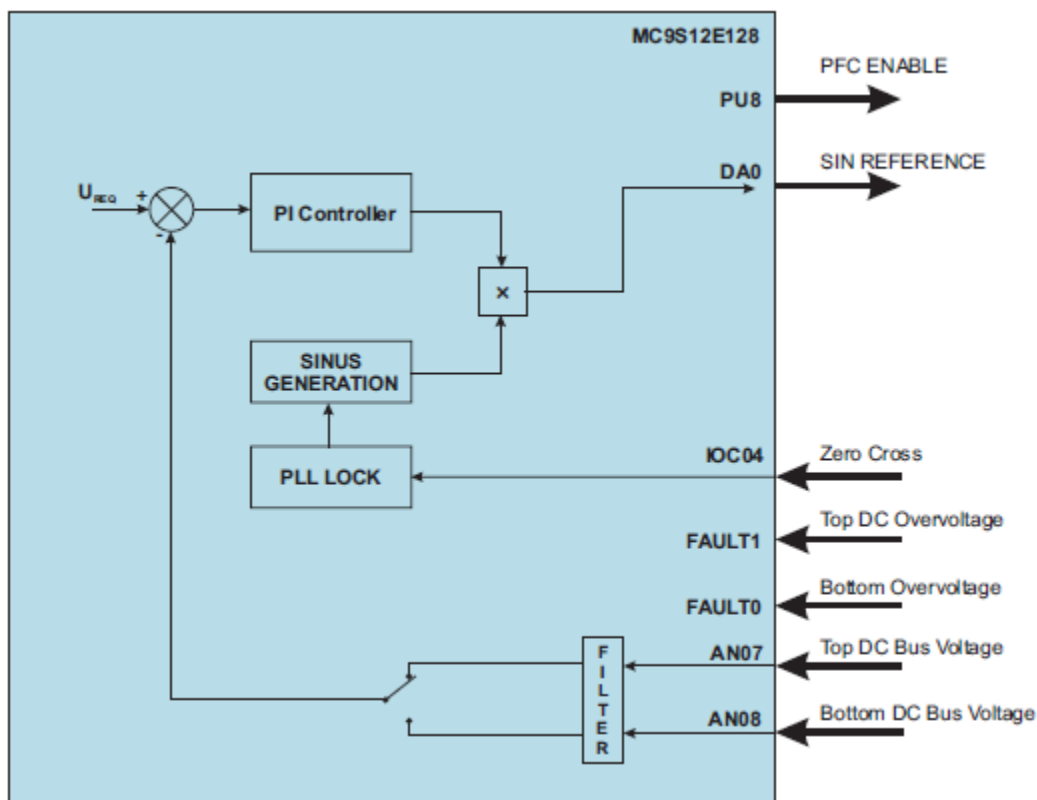

Figure 4.2: PFC control algorithm

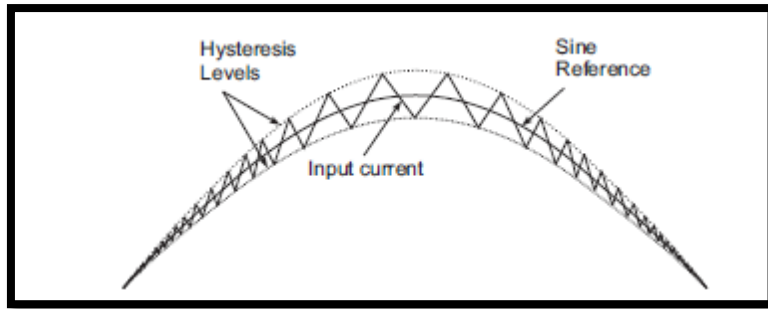

Figure 4.3: Hysteresis Control of Input Current

#### 4.1.3 Dc/dc Step-Up Converter Control

The dc/dc converter uses push-pull topology, which requires the PWM signals as shown in these signals can be generated by one pair of PMF outputs with the following configuration:

- Even output is set to positive polarity
- Odd output is set to negative polarity
- Duty cycle of even output is set to  $X\%$
- Duty cycle of odd output is set to  $100 - X\%$

Where  $X$  is a value from 0 to 50% – dead time

The required PWM patterns are shown in Figure 4.4. The control algorithm is depicted in Figure. Both dc bus voltages pass the digital filter, and their sum is compared with the required value of the dc bus voltage. Based on the error, the PI controller sets the desired duty cycle of the switching transistors.

During mains line operation, the required value of the dc bus is set to 720 V ( $2 \times 360$  V). Because the dc bus is kept by the PFC at 780 V ( $2 \times 390$  V), the dc/dc converter is automatically switched off. In case of mains failure, the dc bus voltage will start to fall. As soon as the voltage reaches the value 720 V, the dc/dc converter is activated. At 720 V, there is still 20 V reserve in amplitude to generate a maximum output voltage of 240 V RMS. As soon as the operation from batteries is recognized, the required value of the dc bus voltage is increased back to 780 V. The PI controller maintains the constant voltage on the dc bus independent of the load until the mains is restored or the battery is fully discharged. If the battery is discharged, the UPS output is deactivated and UPS stays in STANDBY ON BATTERY mode. After 1 minute, the UPS is switched off. The PI controller constants were experimentally tuned in the same way as the PFC. The constants are  $P = 39$  and  $TI = 0.0033$  s. The control loop is calculated every 1 ms.

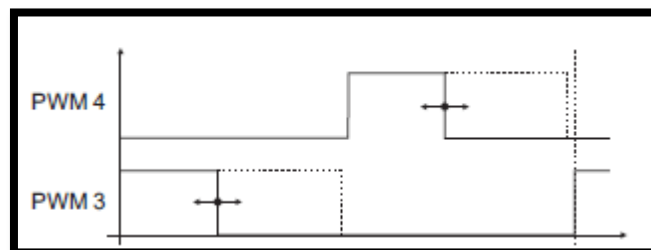
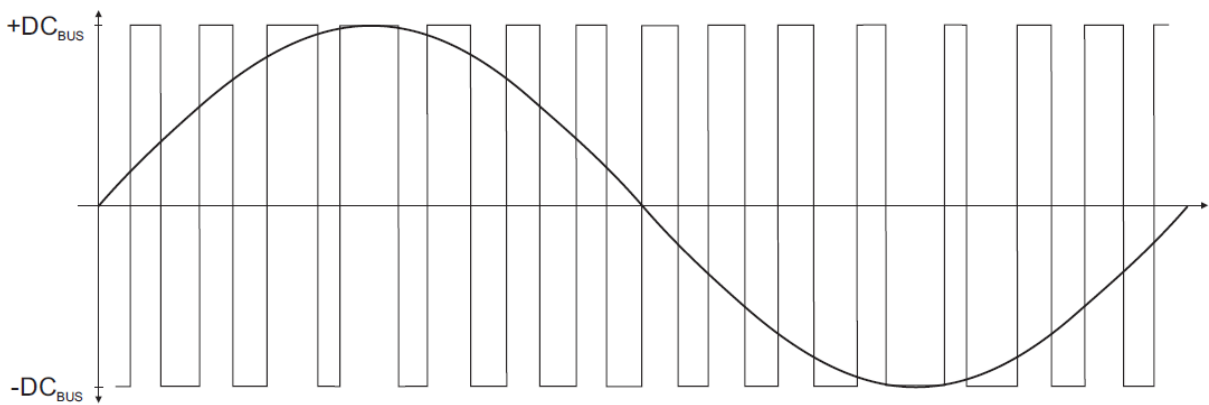

Figure 4.4: Push-Pull Converter PWM Patterns

#### 4.1.4 Output Inverter Control

The output inverter is implemented by two IGBT transistors in half bridge topology. The inverter is fully digitally controlled and generates a pure sine wave voltage. The sine waveform is generated using the pulse-width modulation technique. The sine reference is stored in a look-up table. The table values are periodically taken from the table, and then multiplied by the required amplitude. The resulting value gives the duty cycle of the PWM output. The pointer to the table is incremented by a value, which corresponds to the desired output frequency. All values over one period give sinusoidal modulated square wave output (see Figure 4.5). If such a signal passes through a LC filter, the pure sine wave voltage is generated on the inverter output.



*Figure 4.5: Sine Wave Modulation*

The control algorithm can be seen in Figure 4.6. The main control loop comprises of the PID controller and a feed forward control technique. The required value entering the PID controller is generated by a sine wave generator, optionally synchronized with input voltage. The same value is added directly to the output of the PID controller. It is called the feed forward technique, and it improves the responds of control loop. The amplitude of the sine wave reference is corrected by RMS correction, which keeps the RMS value of the output voltage independent of any load. The RMS correction uses the PI controller. The PI constants were experimentally tuned, and set to  $P = 0$  and  $TI = 0.00936$ .

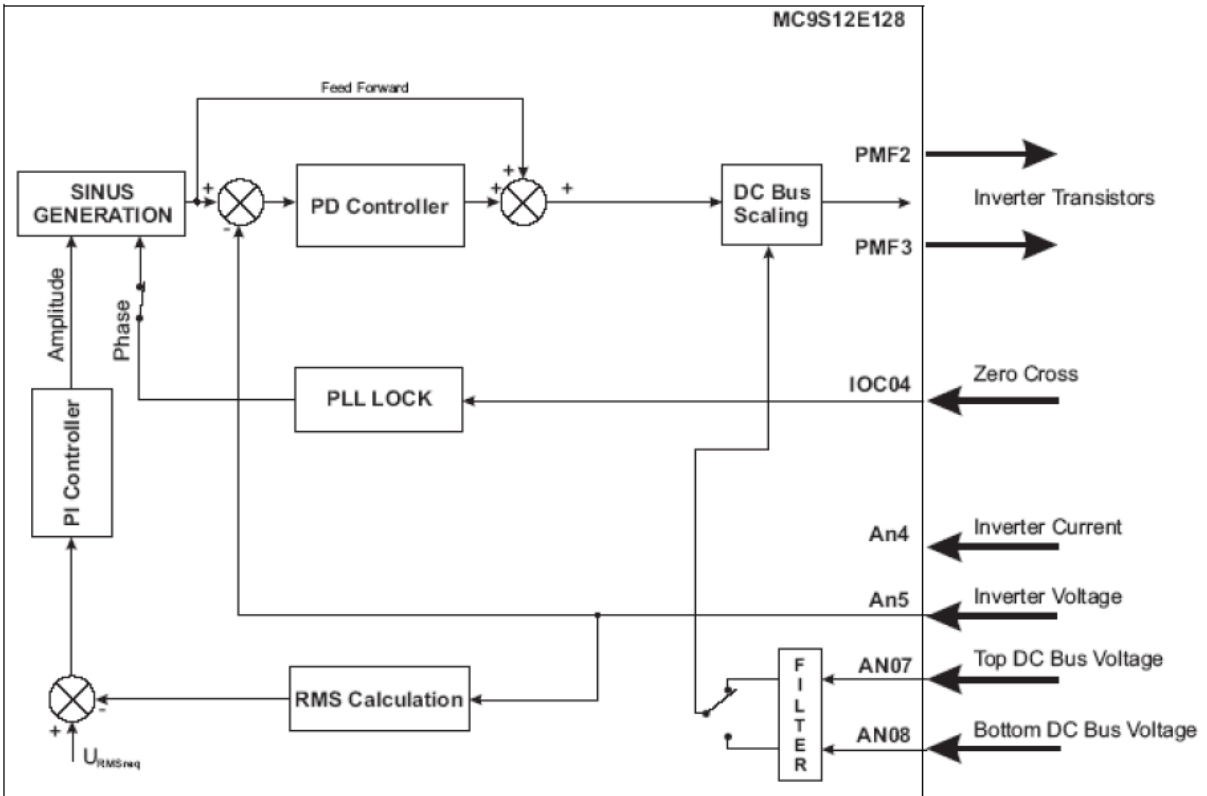

Figure 4.6: Inverter Control Algorithm

Chapter 5

# Hardware Design

## 5.1 Uninterruptible Power Supply (UPS): Basic Circuit Diagram

This is the circuit diagram of a simple UPS that can deliver 12V unregulated and 5V regulated DC. The transformer T1 steps down the mains voltage to 12V AC and then the bridge B1 rectifies it. The rectified signal is smoothed by the capacitor C1. When the mains supply is available the battery will be charged via diode D3 and the regulator IC gets supply via diode D5. 12V and 5V DC will be available at the output terminals. When mains supply is not available the battery supplies current to the regulator IC and to the 12V DC terminal through diode D4. Also, the diode D3 blocks reverse flow of current during battery mode. Capacitors C2 and C3 acts as filters.

The circuit drawn pertains to a regular industrial UPS (Uninterruptible Power Supply), which shows how the batteries take control during an outage in electrical supply or variation beyond the normal limits of the voltage line, without disruption on the operation providing a steady regulated output (5 Volts by LM7805) and an unregulated supply (12 Volts).

The input to the primary winding of the transformer (TR1) is 240V. The secondary winding can be raised up to 15 Volts if the value is at least 12 Volts running 2 amps. The fuse (FS1) acts as a mini circuit breaker for protection against short circuits, or a defective battery cell in fact. The presence of electricity will cause the LED 1 to light. The light of LED will set off upon power outage and the UPS battery will take over

The circuit was designed to offer more flexible pattern wherein it can be customized by using different regulators and batteries to produce regulated and unregulated voltages. Utilizing two 12 Volt batteries in series and a positive input 7815 regulator, can control a 15V supply.

Industrial UPS are generally categorized as: Stand by battery backup and surge protection Line Interactive variable-voltage transformer and regulates the input AC voltage online supplies all or at least a part of the output power

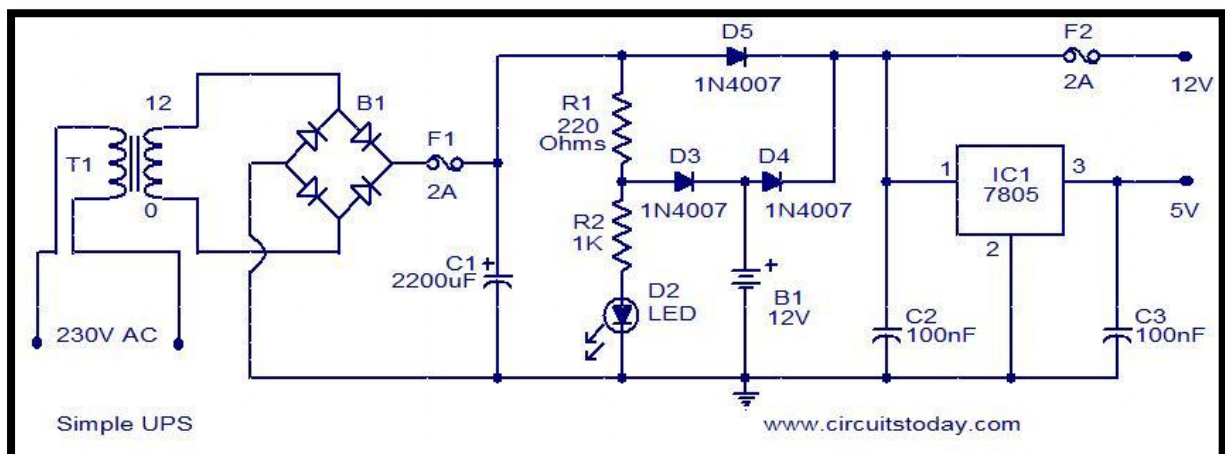

Figure 5.1: Circuit diagram of an UPS

## 5.2 Design criteria and selection

The UPS selection process involves several steps as discussed briefly here. a. Determine need. Prior to selecting the UPS it is necessary to determine the need. The types of loads may determine whether local, state, or federal laws mandate the incorporation of an UPS. An UPS may be needed for a variety of purposes such as lighting, startup power, transportation, mechanical utility systems, heating, refrigeration, production, fire protection, space conditioning, data processing, communication, life support, or signal circuits. Some facilities need an UPS for more than one purpose. It is important to determine the acceptable delay between loss of primary power and availability of UPS power, the length of time that emergency or backup power is required, and the criticality of the load that the UPS must bear.

All of these factors play into the sizing of the UPS and the selection of the type of the UPS.

- A. Determine safety:** It must be determined if the safety of the selected UPS is acceptable. The UPS may have safety issues such as hydrogen accumulation from batteries, or noise pollution from solid-state equipment or rotating equipment. These issues may be addressed through proper precautions or may require a selection of a different UPS.
- B. Determine availability:** The availability of the selected UPS must be acceptable. The criticality of the loads will determine the necessary availability of the UPS. The availability of an UPS may be improved by using different configurations to provide redundancy. It should be noted that the C4ISR facilities require a reliability level of 99.9999 percent.
- C. Determine maintainability:** The selected UPS must be maintainable. Maintenance of the unit is important in assuring the unit's availability. If the unit is not properly cared for, the unit will be more likely to fail. Therefore, it is necessary that the maintenance be performed as required. If the skills and resources required for the maintenance of the unit are not available, it may be necessary to select a unit requiring less maintenance.
- D. Determine if affordable:** The selected UPS must be affordable. While this is the most limiting factor in the selection process, cost cannot be identified without knowing the other parameters. The pricing of the unit consists of the equipment cost as well as the operating and maintenance costs. Disposal costs of the unit should also be considered for when the unit reaches the end of its life.
- E. Re-evaluate steps:** If these criteria are not met, another UPS system must be selected and these steps re-evaluated. The basic static UPS system consists of a rectifier-charger, inverter, static switch, and battery. The rectifier receives the normal



alternating current (ac) power supply, provides direct current (dc) power to the inverter, and charges the battery. The inverter converts the dc power to ac power to supply the intended loads. The dc power will normally be provided from the rectifier, and from the battery upon failure of the primary ac power source or the rectifier. The inverter will supply the loads under normal conditions. In the event of the failure of the inverter, the static switch transfers the load to an alternate ac source.

Normal operation during normal operation, the rectifier converts the ac input power to dc power with regulated voltage. The rectifier output is normally set at the battery float voltage to charge the battery while supplying dc power to the inverter. The rectifier output voltage is periodically set at the battery equalize voltage to maintain the battery capacity. The dc filter (inductor) is provided for smoothing out the rectifier output current to reduce the current ripple content. The battery acts as a capacitor and in conjunction with the filter, smoothes out the output voltage and reduces the dc voltage ripple content. The inverter converts the dc power to ac power with regulated voltage and frequency. An internal oscillator maintains the inverter frequency by controlling the timing of the silicon controlled rectifier (SCR) firing signals and matches the ac input frequency. The filters at the output transformer secondary are provided to filter out the harmonics in the inverter output. Tuned L-C filters are used - when required - to filter out the 5<sup>th</sup> and 7th harmonics while a capacitor is adequate for filtering out the higher order harmonics.

1. Loss of normal power. Upon loss of ac power supply or upon failure of the rectifier, the battery maintains the dc supply to the inverter. The battery can maintain the dc supply to the inverter until the ac supply is restored or to the end of the battery duty cycle. Under this condition, the inverter continues to supply the connected loads without interruption. This mode of operation continues until the system is shut down if the battery reaches the discharged state before the charger output is restored. A system shutdown may be initiated manually or automatically by a dc under voltage sensing device.
2. Restoration of power. Upon restoration of the ac supply after extended outage while the battery has been discharged, the rectifier output voltage is set at the equalizing voltage to recharge the battery. This can be done manually or automatically. The charger will also supply the inverter while recharging the battery. At the end of the battery recharging time, the battery charger returns to the floating mode and the system returns to normal operation.
3. Momentary loss of power. During momentary ac power interruptions or when the ac supply voltage sags below acceptable limits, the battery maintains the dc supply to the inverter. Under this condition, the inverter continues to supply the connected loads with regulated power without interruption.

### 5.3 Bypass mode

The static UPS systems may have three bypass switching arrangements: the UPS static switches (SS), the UPS static switch circuit breaker (SS-CB), and the maintenance circuit breaker.

1. UPS static switch. When an UPS equipment problem occurs, the load is automatically transferred by the static switch bypass to an alternate power source to prevent power interruption to the loads. The static switch is also useful in clearing load faults downstream of the UPS. The static switch will transfer to the alternate power source on a setting of 110 to 125 percent of rated load. Without this feature, the inverter would be driven to current limit on a fault. The inverter would not supply sufficient current to trip the breaker and would continue to feed the fault causing a potential hazard. The transfer of the fault to the alternate power source by the static switch allows full short circuit current to pass through, thus tripping the circuit breaker. The static switch will then transfer back to the UPS for normal operation. Because the circuit cannot differentiate between an inrush and a fault current, it is common for the initial energization of a load to cause a temporary transfer to the alternate source power. When the inverter logic drops below a predetermined value, the bypass SCRs are gated-on by the static switch logic board and the UPS bypass line will supply the load. Retransfer to the UPS module can occur automatically when the logic senses that the UPS output problem has been eliminated. The logic system circuitry maintains the inverter output in synchronization with the UPS bypass power. The configuration of figure 2-2 does not provide the isolation capability of the figure 2-3 system. Reverse parallel SCRs can also be used as UPS power interrupters, that is, as an on-off switch to isolate a failed inverter occurring in a redundant UPS configuration.
2. UPS static switch with circuit breaker (SS-CB). A hybrid UPS system uses an electromechanical switch in the inverter output with the reverse parallel SCRs provided only in the UPS bypass line. With an UPS output malfunction, the UPS bypass static switch will be turned on before the inverter output circuit breaker automatically opens. This type of hybrid switching will need only a short-term static switch current carrying (heat) rating and provides a normally reliable configuration if there are no problems with the circuit breaker closing in the static switch's 300 milliseconds (ms) rating. Figure 2-4 shows a SS-CB configuration where circuit breaker SS-CB closes after the UPS bypass static switch closes. The circuit breaker SSCB provides a bypass for the static switch and therefore allows for the use of a short-term static switch current carrying (heat) rating. To prevent any damage to the static switch the circuit breaker must be able to close within the static switch's short time rating. There have been problems even though manufacturers quote a 450,000-hour mean-time-before-failure, so this system cannot be considered as reliable as a fully rated UPS bypass static switch. Hybrid switching is used as a method of combining the merits of both a static switch and a circuit breaker, that is, both speed and economy.

3. Maintenance bypasses circuit breaker. A bypass circuit breaker is provided to bypass the complete UPS system when maintenance of the UPS system is required. The UPS bypass line provides power continuity during UPS module malfunction periods. If the malfunction is such as to require UPS maintenance, then the load must be shifted to a maintenance bypass line, as shown on figure 2-5. An explanation as to why such a transfer is needed and the how such a transfer is configured is basic to comprehending UPS maintenance procedures.

Purpose of maintenance bypass switch. It is unsafe to work on an energized UPS system. The complete system must be isolated from ac inputs, ac outputs, and the dc link whenever maintenance requires that the cabinet doors be opened and/or protective panels be removed. There are lethal voltages present in UPS cabinetry, resulting from the ac power applied to the converter or the dc power available from the battery. When energized, these circuits provide high voltage. Any portions of the system providing a redundant path, such as more than one UPS module or the static bypass, are tied together by the system logic so partial system shut down for maintenance is not acceptable. Shutting off the battery for maintenance and running the UPS portion as a power conditioner should not be attempted since this also impacts on the system logic. After shutdown, all UPS systems should be load tested off-line. Approximately 85 percent of system failures occur after maintenance shutdowns which were not off-line load tested to assure proper operation. In order to shut down the complete UPS system, the load must be transferred to a line which is isolated electrically from the power and logic circuitry of the entire UPS installation.

Operation of maintenance bypass switch. Close the UPS static bypass, which automatically opens the UPS module output circuit breaker (UPS-CB), allowing closing of the maintenance bypass circuit breaker (MBP-CB) before opening the UPS output circuit breaker (OUTPUT-CB). A closed transition has been made to an alternate supply for input to the critical load with no interruption. Now the UPS system as a whole can be de-energized for maintenance and off-line load testing. This is the basis for the interlocking requirement.

Test mode. Off-line load testing of UPS systems after installation and scheduled maintenance is always necessary. A permanent load test tap or a circuit breaker and interlocking circuitry may be provided as part of the installation. Otherwise a temporary connection must be provided.

Characteristics and limitations: To avoid drawing heavy inrush currents from the power source upon initial energization, the battery charger is designed to assume the load gradually. Normally, the start-up current is limited to a maximum of 25 percent of the full load current. The current is then automatically increased gradually to the full load value in 15 to 30 seconds this time is termed the "walk-in" time. For this reason all loads cannot be switched simultaneously if the battery has been fully discharged. Upon sudden application

or removal of a load, the inverter's output voltage will drop or rise beyond the steady-state level. The voltage then returns to the steady-state condition after some short time which depends on the inverter's voltage control circuit design. These voltage variations are termed transient voltage response and the time required to return to steady-state conditions is termed the recovery time. Generally, due to the absence of feedback regulating circuits in inverters with a ferroresonant transformer, the transient response is slower than that of inverters with pulse width or pulse width modulation (PWM) control techniques. SCRs have a limited overload capability. Also, heavy load currents may cause commutation failures. Therefore, the rectifier and inverter are designed to be self protected from overloads. The self protection circuit reduces the output voltage at currents exceeding the full load current. Normally, the inverter is designed to reduce the output voltage to zero at overloads of 115 to 135 percent rated load. The value of over current at which the voltage is reduced to zero is termed "current limit." The inverter may reach the current limit condition when energizing a load with a high inrush current or during a load branch circuit fault.

Basic static UPS system without a dedicated battery: The basic system discussed above utilizes a dedicated battery as a backup source. The UPS system is provided with a controlled rectifier to supply the inverter and float/equalize charge the battery. In other applications, a large battery bank may be available for supplying the UPS system as well as other loads. In such applications, a separate battery charger is provided to supply the connected load and float/equalize the battery. In this case, the UPS system is provided with a rectifier that only supplies the inverter and is isolated from the battery and other loads by a blocking diode. The blocking diode allows current to flow from the battery to the inverter while blocking the flow of current from the rectifier to the battery. Upon failure of the ac input power, the battery supplies the inverter as discussed above.

Principles of rectifiers and inverters: UPS systems use power semiconductors in the construction of the rectifiers, inverters, and static switches. These solid-state devices control the direction of power flow and switch on and off very rapidly allowing for the conversion of power from ac to dc and dc to ac.

Power semiconductor characteristics: A power semiconductor is an electronic device consisting of two layers of silicon wafer with different impurities forming a junction made by diffusion. The joining of these two wafers provides control of the current flow. Referring to figure 2-6, the power semiconductor permits the current to flow in one direction from the anode A to the cathode K, whenever the anode voltage is positive relative to the cathode. When the anode voltage is negative relative to the cathode, the power diode blocks the flow of current from the cathode to the anode. The power semiconductors may be either SCR or transistors. The types of transistors are bipolar transistors, field effect transistors (FET), and insulated gate bipolar transistors (IGBT). The devices most commonly used are the SCRs and the IGBTs. The IGBTs are relatively new and have been gaining in popularity. The IGBTs are significantly more efficient and

easier to control than the other power semiconductors. The use of IGBTs has allowed for static UPS as large as 750 kVA without paralleling units.

#### 5.4 Single-phase SCR characteristics

An SCR allows for forward flow of current through the device similar to a diode. The SCR differs from a diode in that the SCR will not conduct until a current pulse is received at the gate. Once the SCR is conducting, it will only turn off with the current falling to zero or through a reverse current being applied. Referring to, the anode voltage is positive relative to the cathode between  $\omega t = 0$  and  $\omega t = \alpha$ ; the SCR begins conducting when a firing pulse is applied at  $\omega t = \alpha$ . Here,  $\alpha$  is called the firing angle. Also, the SCR blocks at  $\omega t > \alpha$  when the anode voltage becomes negative relative to the cathode. The SCR does not conduct again until a firing pulse is reapplied at  $\omega t = 2\pi + \alpha$ . While turning on the SCR is very efficient, the SCRs require a commutation circuit to turn it off. It is necessary to be able to turn off the device for use in the inverter to generate the ac wave. The turn-off time is slow in comparison to the transistors which are not latching devices. The other drawbacks to the commutation circuit are that it adds more equipment to the circuit, adds audible noise to the unit, and consumes power. Battery charging during initial operation, the battery requires charging. During normal operation, local chemical reactions within the cell plates cause losses that reduce the battery capacity if not replenished. Also, these local chemical reactions within the different cells occur at varying rates. In lead-acid batteries these local reactions over long periods of time cause unequal state-of-charge at the different cells. In addition, it is required to recharge the battery following a discharge. Therefore, the battery charger should provide the initial charge, replenish the local losses to maintain the battery capacity, equalize the individual (lead-acid) cells state-of-charge, and recharge the battery following discharge. In stationary applications such as static UPS systems, the battery is continually connected to the charger and the load and the battery is float charged. During float charging the battery charger maintains a constant dc voltage that feeds enough current through the battery cells (while supplying the continuous load) to replenish local losses and to replace discharge losses taken by load pulses exceeding the charger's current rating. Periodically the charger voltage is set at a level 10 percent higher than the floating voltage to restore equal state-of-charge at the individual (lead-acid) cells. This mode of charging is called "equalizing charge" and the charger voltage level during this mode is the equalizing voltage. Following the battery discharge, the charger is set at the equalizing voltage to recharge them battery. The charger is set at this higher voltage to drive a higher charging current to recharge the battery in a reasonably short time and to restore it to the fully charged state. Although a periodic equalizing charge is not required for equalizing ni-cad cells, a charger with float/equalize mode is required. At the floating voltage level, the ni-cad cell cannot be charged over 85 percent of its full capacity. Therefore, the equalizing voltage level is required to fully recharge the cell after successive discharges.

Table 5.1: Characteristics of UPS battery types

Battery Type	Typical Warranty Period	Typical Expected Life	Approximate Number of Full Discharges
Lead-acid antimony, flooded electrolyte	15 years	15 years	1,000-12,000
Lead-acid calcium, flooded electrolyte	20 years	20 years	100
Lead-acid/calcium gelled electrolyte, valve-regulated	2 years	5 years	100
Lead-acid/calcium suspended electrolyte, valve-regulated	1 - 10 years	5 - 12 years	100-200
Lead-acid special alloy suspended electrolyte, valve-regulated	14 years	14 years	200-300
Lead-acid/pure starved electrolyte, valve-regulated	1 year	5 - 20 years	150
Ni-cad, flooded electrolyte	20 - 25 years	25 years	1,000-1,200

- Voltage tapping:** Sometimes the UPS system will require one dc voltage level while electrical operation of circuit breakers will require another dc voltage level. Tapping off of the higher-voltage battery is not permitted. Unequal loads on the battery will reduce the battery's life since it causes one portion of the battery to be undercharged while the other portion is overcharged. Battery and UPS manufacturers both often indicate that such practices invalidate their warranties
- Cycling effects:** A cycle service is defined as a battery discharge followed by a complete recharge. A deep or full cycle discharge/recharge consists of the removal and replacement of 80 percent or more of the cell's design capacity. Cycling itself is the repeated charge/discharge actions of the battery. A momentary loss of power can transfer the UPS to the battery system and impose a discharge on the battery for the time period needed by the UPS to determine whether the ac power input has returned to acceptability. As we see an increase in non-linear loads, we may expect to see more frequent cycling. As indicated in table 2-1, the ability of flooded lead-acid batteries utilizing a lead-antimony alloy to provide the greatest number of full discharges. Ni-cad batteries have a good cycle life, but their increased cost does not encourage their use in large installations. Valve-regulated batteries have low-cycle capabilities because each recharge means a possibility of some gassing, resulting in the ultimate failure of the cell when it eventually dries out.
- Charging/discharging considerations:** A battery cannot function without a charger to provide its original and replacement energy. A well designed charger will act to charge a discharged battery by maintaining the correct balance between overcharging and undercharging so as not to damage the battery. Additionally, the charger must assure that battery discharging is limited to the point where the cells approach exhaustion or where the voltage falls below a useful level (usually about 80 percent of the batteries rated capacity). Overcharging results in increased water use and over



discharging tends to raise the temperature, which may cause permanent damage if done frequently.

- **Current flow:** Batteries are connected to the charger so that the two voltages oppose each other, positive of battery to positive of charger and negative to negative. Battery current flow is the result of the difference between the battery and the charger voltages and the battery's extremely low opposing resistance. The voltage of the battery rises during charging, further opposing current flow. Chargers are designed to limit starting charging currents to values that keep equipment within a reasonable size and cost. They must also maintain a sufficiently high current throughout charging so that at least 95 percent of the complete storage capacity is replaced within an acceptable time period. This recharge time may range from 5 to 24 times the reserve period (for a 15 minute reserve period with a 10 times recharge capability the recharge period would be 2.5 hours).
- **Voltage action:** Providing the precise amount of charge on each and every cell for each and every recharge is impracticable for a continuously floating battery operation. The float voltage point should just overcome the battery's self-discharge rate and cause the least amount of corrosion and gassing. Ambient temperature differences will affect the charging ability of the selected float-voltage level. Overcharge, undercharge, and float voltage levels differ, depending upon the type of cell used.
- **Lead – acid cells:** The usual recommended float voltage for UPS applications is 2.20 to 2.30 volts per cell depending upon the electrolyte's specific gravity. The excess energy of higher float voltages results in loss of water, cell gassing, accelerated corrosion, and shorter cell life. To eliminate such actions, the charge is stopped slightly short of a fully-charged condition on daily or frequent discharges. However, permissible cell manufacturing tolerances and ambient temperature effects will cause individual cell-charge variations. Sulphation will take place and not be reconverted upon recharge, since the charge is insufficient to draw all the acid from the plates. The sulphate may start to crystallize and be shed from the plate. To prevent this, an "equalizing" charge is given for a selected time period to provide a complete recharge on all cells. However, excessive equalizing charges will have an adverse effect on battery life. Automatic equalizing after a discharge may require less maintenance time but may affect battery life. Equalizing charges on a periodic basis are not recommended but should follow the manufacturer's guidelines. Equalizing charging should be considered a corrective action rather than routine maintenance. Periodic equalizing charges can be considered as treating a possible problem before determining that there is a problem.
- **Ni-cad cells:** The usual recommended float voltage for UPS applications is 1.38 to 1.47 volts per cell depending upon the manufacturer's recommendation. Overcharge, as such, may cause no harm to the battery although there will be water loss. The

current rate used for charging, though, could produce a damaging heating effect during any appreciable overcharge. Equalizing is not as important for this type of battery, but may be recommended to assist in electrolyte mixing after addition of water.

- **Ripple currents:** UPS applications can place unusual load conditions on a battery, and one condition that increases the rate of battery breakdown is ripple current. Ripple current is caused by the ripple voltage of the battery charger output and by the pulsating current requirements of the inverter. The UPS battery design strives for excellent short-term, high-rate, current characteristics and this demands the lowest possible internal cell resistance. This low resistance can serve as a better short circuit path for the ripple voltages coming out of the rectifier stage of the UPS than can the filter capacitors in the output rectifier. Also, the inverter stage of the UPS demands large instantaneous dc currents as it builds ac power from the parallel rectifier/battery combination. If the UPS is located some distance from the commercial ac power source, the short-term instantaneous currents must then come from the battery. These factors can result in a relatively high ac component in the UPS battery. The relative detrimental effects of ripple current on the battery are mainly a function of the design of the UPS, the comparative size of the battery as compared to the UPS rating, and the battery type. Ripple current tends to heat the batteries and is equivalent to constantly discharging and recharging the battery a tiny amount. Ni-cad cells can be adversely affected by ripple currents although they provide a very good filtering capability. Lead, being much softer than nickel, requires different plate construction techniques which make lead-acid batteries even more susceptible to harmful effects from ripple currents. Usually ripple currents of less than 5 percent over the allowable continuous input range of the battery will not be harmful to lead-acid batteries. A lead-acid battery operated on a high ripple current input at an elevated temperature can have its operating life reduced to one quarter of what would normally be expected.
- **Memory effect:** Ni-cad cells charged at very low rates are subject to a condition known as a "memory effect." Shallow cycling repeated to approximately the same depth of discharge leads to continual low-rate charging. The result is a battery action which has reduced the effective reserve time of the UPS system. An affected cell can have the memory effect erased by providing a complete discharge followed by a full charge with constant current which breaks up the crystalline growth on the plates. *m.*

### 5.5 Effects of loads on static UPS systems

Linear loads present constant load impedance to the power source. This type of load results in a constant voltage drop. However, non-linear loads draw non-sinusoidal current resulting in a non-sinusoidal voltage drop. Non-linear loads and loads with high inrush current demand could adversely affect the static UPS system performance.



- **Non-linear loads:** Non-linear loads are loads whose current is not proportional to the supply voltage such as loads with ferroresonant transformers or regulating transformers and solid state power supplies. Non-linear loads distort the inverter output voltage wave shape and cause the output voltage to contain high harmonic content. This effect can be more pronounced in inverters with high impedance such as inverters with pulse width control technique and inverters with a ferroresonant output transformer.
- **Loads with high inrush current:** Loads such as motors, transformers, incandescent lamps, etc., draw a high initial current when energized. The high initial current for such loads could be as high as 10 times the normal full load current. Therefore, loads with high inrush current requirements should not be energized simultaneously otherwise the inverter may reach the current limit point. n. Effect of static UPS system on power supply system. The battery charger within the static UPS is a controlled rectifier which draws non-sinusoidal currents from the power source. The ac line current drawn is basically a square wave or a stepped wave depending on the charger design. This square or stepped wave can be analyzed into an equivalent sinusoidal wave of the power frequency (i.e., the fundamental component) plus other sinusoidal waves of higher frequencies or harmonics. These harmonic currents cause harmonic voltage drops in the power source impedance. This results in power source voltage distortion and the flow of harmonic currents in the power system components and loads. The degree of power source voltage distortion increases with the static UPS system capacity as well as the power source equivalent impedance. The flow of harmonic currents in the power system can cause resonance and additional losses and heating in the power source's components and loads.

Normally, a static UPS system does not have detrimental effects on the power supply system. However, when the static UPS system capacity is close to 20 percent of the supply system capacity, the harmonic effects should be analyzed. The effect of the UPS generated harmonics on the power source and other supplied equipment can be minimized when necessary. The use of a 12- (or more) pulse rectifier reduces the harmonic currents generated. The harmonic currents present in input current to a typical rectifier in per-unit of the fundamental current are as shown in table 2-2. However, the rectifier number of pulses is an equipment specific design parameter that is not normally specified by the user. Should the UPS generated harmonics become a problem and affect other loads supplied from the same bus as the UPS, harmonic filters at the UPS input may be used. Harmonic filters filter out the harmonic currents and minimize the voltage distortion and its effects on harmonic susceptible equipment.

Chapter 6  
**Conclusion**

## 6.1 Conclusions

It can be concluded that the sole aim of carrying out the design, analysis and implementation of a smart embedded personal computer uninterrupted power supply system was achieved, in that the aim was to develop a cheap, affordable, reliable and efficient smart embedded system, which was successfully realized at the end of the design process. The whole concept of the system cuts across the hardware implementation and software implementation. The power module generated an output that conveniently powers a personal computer and the control module do the master channeling of device outputs and inputs though they are controlled mainly by the assembly code on which the microcontroller runs on. However similar implementation existed before now and was called internal UPS. Unique to this design however is the principle behind the control of the module, whereby a 5V microcontroller has to read a source of 12V (DC).

Various UPS types are appropriate for different uses, and no single UPS type is ideal for all applications. The intent of this paper is to contrast the advantages and disadvantages of the various UPS topologies on the market today.

Significant differences in UPS designs offer theoretical and practical advantages for different purposes. Nevertheless, the basic quality of design implementation and manufactured quality are often dominant in determining the ultimate performance achieved in the customer application.

Businesses today invest large sums of money in their IT infrastructure, as well as the power required to keep it functioning. They count on this investment to keep them productive and competitive. Leaving that infrastructure defenseless against electrical dips, spikes and interruptions, therefore, is a bad idea.

A well-built power protection solution, featuring high-quality, highly efficient UPS hardware, can help keep your business applications available, your power costs manageable and your data safe. By familiarizing themselves with the basics of what a UPS does and how to choose the right one for their needs, data center operators can ensure that mission-critical systems always have the clean, reliable electricity they need to drive long-term success.

## References

- [1] Single Phase On-Line UPS Using MC9S12E128 Free scale Semiconductor.
- [2] Hamblen,J.O, Using a low cost Soc computer & commercial RTOS in an embedded system design course.IEEE transaction on education 51(3),PP(356-363).
- [3] Battery charging basics & charging algorithm fundamentals “detrain corporation”
- [4] [www.imca-int.com](http://www.imca-int.com)
- [5] Samstad j.Hofj M-technical comparison online vs. line interactive UPS design SPC white paper #79.
- [6] DNV rules for ships-part 4, chapter 8.january 2008-electrical installation.
- [7] ABS rules effects of harmonics 2006.
- [8] Approved for public Release; Distribution is unlimited.
- [9] A.B.C Treaning manual issue-1 January 2002.
- [10]Infineon Technologies AG 81726 munchen,Jermany@infineon Technologies AG 2007.