



AC TO DC MINI IPS

Daffodil International University

Department of Electrical & Electronic Engineering

**This Report submitted in partial fulfillment of the requirement
for the degree of Bachelor of Science in Electrical and
Electronic Engineering.**

Supervised

Prof. Dr. M. Shamsul Alam

Professor and Dean

Faculty of Science And Information Technology

Daffodil International University

Undertaken By

Md:Humayan Kabir

ID. 103 - 33 – 378

Md:Shahriar Shawn

ID. 103 – 33 -363

LETTER OF TRANSMITTAL

To

Prof. Dr. M. Shamsul Alam

Professor and Dean

Faculty of Science And Information Technology

Daffodil International University

Subject: Submission of project Report

Sir,

We are hereby pleased to submit the project report on “AC to DC mini ips”. It was a pleasure to work on such an important topic. This project work was done according to the requirements of the Daffodil International University.

We believe that this project report will be acceptable to you in partial fulfillment of the requirement for awarding the degree of Bachelor of Science in Electrical & Electronic Engineering.

Sincerely Yours

Obediently yours,

Md:Humayan Kabir

ID.103-33-378

Md.Shahriar Shawn

ID.103-33-363

DECLARATION

We hereby declare that this project report on “AC to DC mini ips” is submitted to Daffodil International University for partial fulfillment of the requirement of the degree of B.Sc. in Electrical & Electronic Engineering. It has not been submitted to any other University or institution for the award of any degree previously. This project report does not breach any provision of copy right act.

We further undertake to indemnify the university against any loss or damage arising from breach of the forgoing obligation.

.....
Md:Humayan Kabir
ID.103 – 33 – 378

.....
Md.Shahriar Shawn
ID. 103 – 33 – 363

Supervisor

.....
Prof. Dr. M. Shamsul Alam

Professor and Dean

Faculty of Science And Information Technology

Daffodil International University

ABSTRACT

This is to certify that, the project report on AC to DC mini ips is done by Md:Humayan Kabir And Md.Shahriar Shawn for partial fulfillment of the requirement of the degree of B. Sc. in Electrical & Electronic Engineering program from the Daffodil International University.

The dissertation has been carried out under my guidance and is a record of bona fide work carried out successfully.

Faculty Guide

Prof. Dr. M. Shamsul Alam

Professor and Dean

Faculty of Science And Information Technology

Daffodil International University

Dhaka-1207, Bangladesh

ACKNOWLEDGEMENT

Before we get into think of project we would like to add a few heartfelt words for the people who guided us in bringing this entire project successfully.

We acknowledge my gratitude to our thesis supervisor, Prof. Dr. M. Shamsul Alam ,Professor and Dean, Faculty of Science And Information Technology,Daffodil International University for his valuable suggestions and guidance throughout this project work.

We are grateful to our honorable Vice Chancellor, Professor Dr.M. Lutfar Rahman. Daffodil International University for providing golden opportunity for achieving our degree of B.Sc. in Electrical and Electronic Engineering and his best co-operation.

We are grateful to Prof. Dr. Md. Fayzur Rahman, Head of the Department, Electrical and Electronic Engineering, Daffodil International University for his valuable suggestions.

A special mention goes to those who directly or indirectly helped for successful completion of the project work.

Thanks to all

Authors

TABLE OF CONTENTS

CONTENS	PAGE
<i>Letter of transmittal</i>	2
<i>Declaration</i>	3
<i>Certificate</i>	4
<i>Acknowledgement</i>	5
Chapter 1: Introduction	10-12
<i>1.1 Objectives of this work</i>	10
<i>1.2 Preface</i>	10
<i>1.3 Literature Review</i>	10
<i>1.4 Work status</i>	11
<i>1.5 Organization of the project</i>	12

	PAGE
Chapter 2: Diode	13-20
2.1 Diode.....	13
2.2 History.....	13
2.3 Electronic symbols.....	13
2.3.1 Point – contact diode.....	14
2.3.2 P-N junction diode.....	15
2.4 Type of semiconductor diode.....	15
 Chapter 3: voltage Regulator and Transform	 21-27
3.1 Voltage Regulator.....	21
3.2.1 Use IC 7805 voltage Regulator.....	21
3.2.2 Data Sheet.....	22
3.2.3 Pin Diagram.....	22
3.2.4 Pin Description.....	23
3.3 Transformer.....	23
3.3.1 The power Transformer.....	23
3.3.2 Turns Ratio.....	24
3.4 Induction Law.....	25
3.4.1 Leakage Flux.....	26

	PAGE
Chapter 4: Rectifier	28-34
4.1 Rectifier.....	28
4.2 The Full Wave Rectifier.....	28
4.3 Full Wave Rectifier Circuit.....	29
4.4 The Full Wave Bridge Rectifier.....	30
4.5 The Diode Bridge Rectifier.....	31
4.5.1 The Positive Half-Cycle.....	32
4.5.2The Negative Half-Cycle.....	32
4.6 The Smoothie Capacitor.....	32
4.7 Full- Wave Rectifier with Smoothing Capacitor	33
Chapter 5: Capacitor	35-46
5.1 Capacitor.....	35
5.2 History.....	36
5.3 Theory of operation.....	36
5.4 Hydraulic analogy.....	38
5.5 Energy of electric field.....	39
5.6 Current-voltage relation.....	39
5.6.1 DC circuits.....	40
5.6.2 AC circuits.....	41

	PAGE
Chapter 5: Capacitor	35-46
5.7 Capacitor types.....	42
5.8 Dielectric materials.....	42
5.9 Structure.....	44
5.10 Capacitor markings.....	46
Chapter 6: Cost Analysis	47-49
6.1 Cost Sheet Table	39
6.2 Cost Comparison.....	40
6.3 Conclusion.....	41
References.....	42



Chapter -1

Introduction

1.1 Objectives of this work

The objectives of this project are to propose and analyze a new single stage power factor corrected AC/DC mini ips which overcorrect several of the drawbacks mentioned in the previous section. This circuit is not available in market. There are one input and five outputs. We have ac to dc mini ips in Bangladeshi market but it has not backup system. we project have done the same backup 5volt,6volt,9volt,10volt,12volt

1.2 Preface

An ac to dc mini ips is an integral part of any power supply unit used in the all electronic equipments. Also, it is used as an interface between utility and most of the power electronic equipments. These electronic equipments form a major part of load on the utility. Generally, to convert line frequency ac to dc, a line frequency diode bridge rectifier is used. To reduce the ripple in the dc output voltage, a large filter capacitors used at the rectifier output. But due to this large capacitor, the current drawn by this converter is peaky immature. This input current is rich in low order harmonics. Also, as power electronics equipments are increasingly being used in power conversion, they inject low order harmonics into the utility. Due to the presence of these harmonics, the total harmonic distortion is high and the input power factor is poor. Due to problems associated with low power factor and harmonics, utilities will enforce harmonic standards and guidelines which will limit the amount of current distortion allowed into the utility and thus the simple diode rectifiers may not in use. So, there is a need to achieve rectification at close to unity power factor and low input current distortion.

1.3 Literature Review

The circuit drawn pertains to a regular industrial the project, which shows how the batteries take control during an outage in electrical supply or variation beyond the normal limits of the voltage line, without disruption on the operation providing a steady regulated output (5 Volts by LM7805) and an unregulated supply (12 Volts).The input to the primary winding of the transformer (TR1) is 240V. The secondary winding can be raised up to 15 Volts if the value is at least 12 Volts running 2 amp. The fuse (FS1) acts as a mini circuit breaker for protection against short circuits, or a defective battery cell in fact. The presence of electricity will cause

the LED 1 to light. The light of LED will set off upon power outage and the battery will take over

The circuit was designed to offer more flexible pattern wherein it can be customized by using different regulators and batteries to produce regulated and unregulated voltages. Utilizing 12 Volt batteries in a positive input 7805 five regulator, can control a 5V supply

1.4 Work status

We constructed our designed circuit in a bread board. At first clean the transformer, resistor, diode, capacitor, led, voltage regulated IC input output cable insulation and set the bread board. This are input 220v ac and output 14v ac. we added one rectifier circuit in transformer's output side than give the transformer dc14v.fuse one kind of safety device added the rectifier circuit but we need to dc 12volt.we use two paces resister one of 220ohms and two of 1k than resister output give us 12volt.now we add 12volt buttery, now we are complete buttery charging system and than we made backup system.

First select input, output and ground terminal of voltage regulated IC. Input terminal add the positive terminal of buttery and ground terminal add negative terminal of buttery than output voltage sow output terminal of voltage regulated ic.5volt, 6volt, 8volt, 9volt and 10volt similarly connect the buttery terminal.

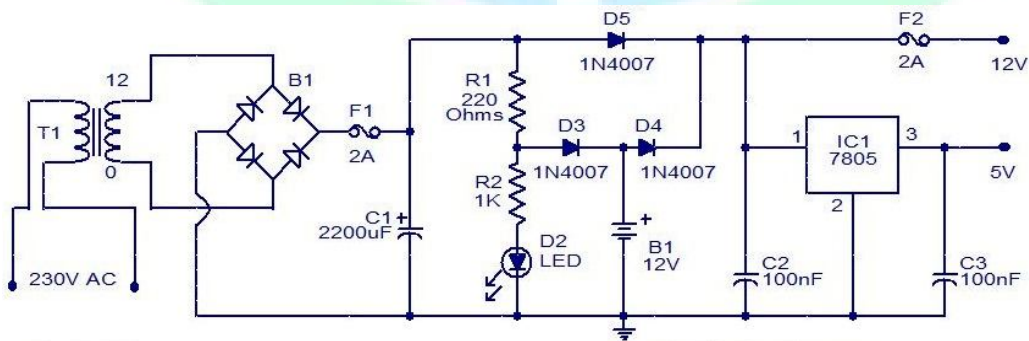

Fig 1.1 (AC to DC mini ips)

1.5 Organization of the project

This project report has Seven chapter in total .The first chapter describes a brief idea about Preface, Literature Review , Objectives of This Work and work status .The second chapter contains theory of diode. In third chapter describes voltage regulator and transformer. Fourth and Five chapters explain the Rectifier and Capacitor. Finally,Six chapter the cost Analysis and cost comparison and Conclusion, and suggestions for the future works.



Chapter -2 Diode

2.1 Diode

The most common function of a diode is to allow an electric current to pass in one direction (called the diode's forward direction), while blocking current in the opposite direction (the reverse direction). Thus, the diode can be viewed as an electronic version of a check valve. This unidirectional behavior is called rectification, and is used to convert alternating current to direct current, including extraction of modulation from radio signals in radio receivers these diodes are forms of rectifiers.

However, diodes can have more complicated behavior than this simple on-off action. Semiconductor diodes begin conducting electricity only if a certain threshold voltage or cut-in voltage is present in the forward direction (a state in which the diode is said to be forward-biased). The voltage drop across a forward-biased diode varies only a little with the current, and is a function of temperature; this effect can be used as a temperature sensor or voltage reference.

Diodes were the first semiconductor electronic devices. The discovery of crystals' rectifying abilities was made by German physicist Ferdinand Braun in 1874. The first semiconductor diodes, called cat's whisker diodes, developed around 1906, were made of mineral crystals such as galena. Today most diodes are made of silicon, but other semiconductors such as germanium are sometimes used.

2.2 History

Thermion (vacuum tube) diodes and solid state (semiconductor) diodes were developed separately, at approximately the same time, in the early 1900s, as radio receiver detectors. Until the 1950s vacuum tube diodes were more often used in radios because semiconductor alternatives (Cat's Whiskers) were less stable, and because most receiving sets would have vacuum tubes for amplification that could easily have diodes included in the tube (for example the 12SQ7 double-diode triode), and vacuum tube rectifiers and gas-filled rectifiers handled some high voltage/high current rectification tasks beyond the capabilities of semiconductor diodes (such as selenium rectifiers) available at the time.

2.3 Electronic symbols

The symbol used for a semiconductor diode in a circuit diagram specifies the type of diode. There are alternate symbols for some types of diodes, though the differences are minor.

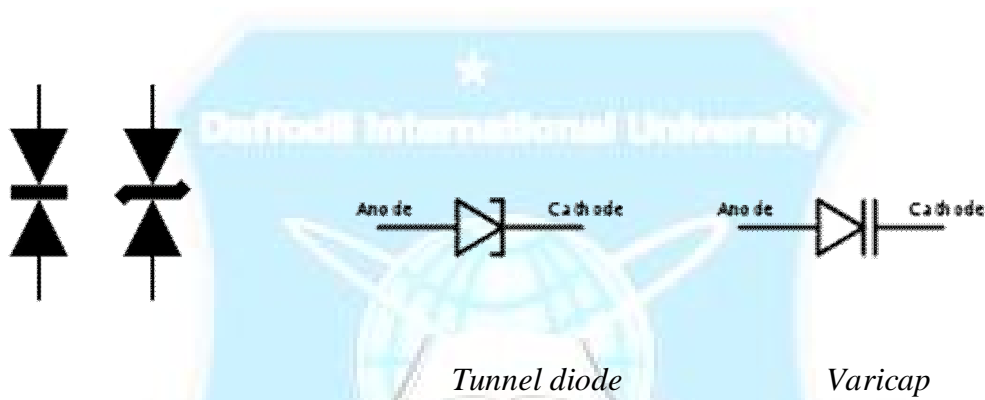
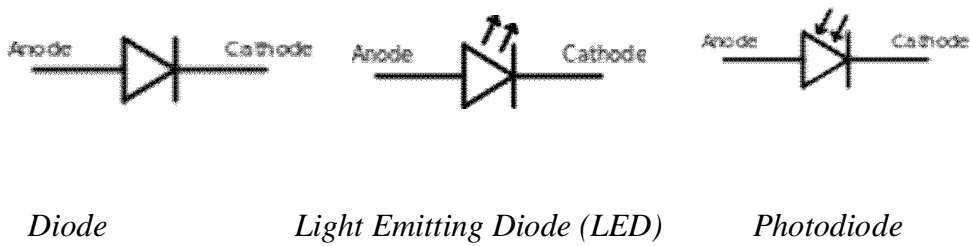

Transient Voltage Suppression (TVS)



2.3.1 Point-contact diodes

A point-contact diode works the same as the junction diodes described below, but their construction is simpler. A block of n-type semiconductor is built, and a conducting sharp-point contact made with some group-3 metal is placed in contact with the semiconductor. Some metal migrates into the semiconductor to make a small region of p-type semiconductor near the contact. The long-popular 1N34 germanium version is still used in radio receivers as a detector and occasionally in specialized analog electronics.

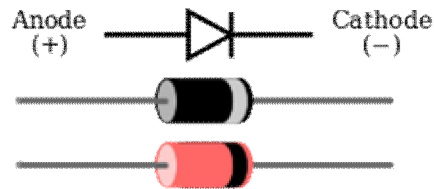

Fig 2.2[Typical diode packages in same alignment as diode symbol. Thin bar depicts the cathode.]

2.3.2 p–n junction diode

A p–n junction diode is made of a crystal of semiconductor. Impurities are added to it to create a region on one side that contains negative charge carriers (electrons), called n-type semiconductor, and a region on the other side that contains positive charge carriers (holes), called p-type semiconductor. When two materials i.e. n-type and p-type are attached together, a momentary flow of electrons occur from n to p side resulting in a third region where no charge carriers are present. It is called Depletion region due to the absence of charge carriers (electrons and holes in this case). The diode's terminals are attached to each of these regions. The boundary between these two regions, called a p–n junction, is where the action of the diode takes place. The crystal allows electrons to flow from the N-type side (called the cathode) to the P-type side (called the anode), but not in the opposite direction.

2.4 Types of semiconductor diode

There are several types of p–n junction diodes, which either emphasize a different physical aspect of a diode often by geometric scaling, doping level, choosing the right electrodes, are just an application of a diode in a special circuit, or are really different devices like the Gunn and laser diode and the MOSFET:

Normal (p–n) diodes, which operate as described above, are usually made of doped silicon or, more rarely, germanium. Before the development of silicon power rectifier diodes, cuprous oxide and later selenium was used; its low efficiency gave it a much

higher forward voltage drop (typically 1.4 to 1.7 V per "cell", with multiple cells stacked to increase the peak

inverse voltage rating in high voltage rectifiers), and required a large heat sink (often an extension of the diode's metal substrate), much larger than a silicon diode of the same current ratings would require. The vast majority of all diodes are the p–n diodes found in CMOS integrated circuits, which include two diodes per pin and many other internal diodes.

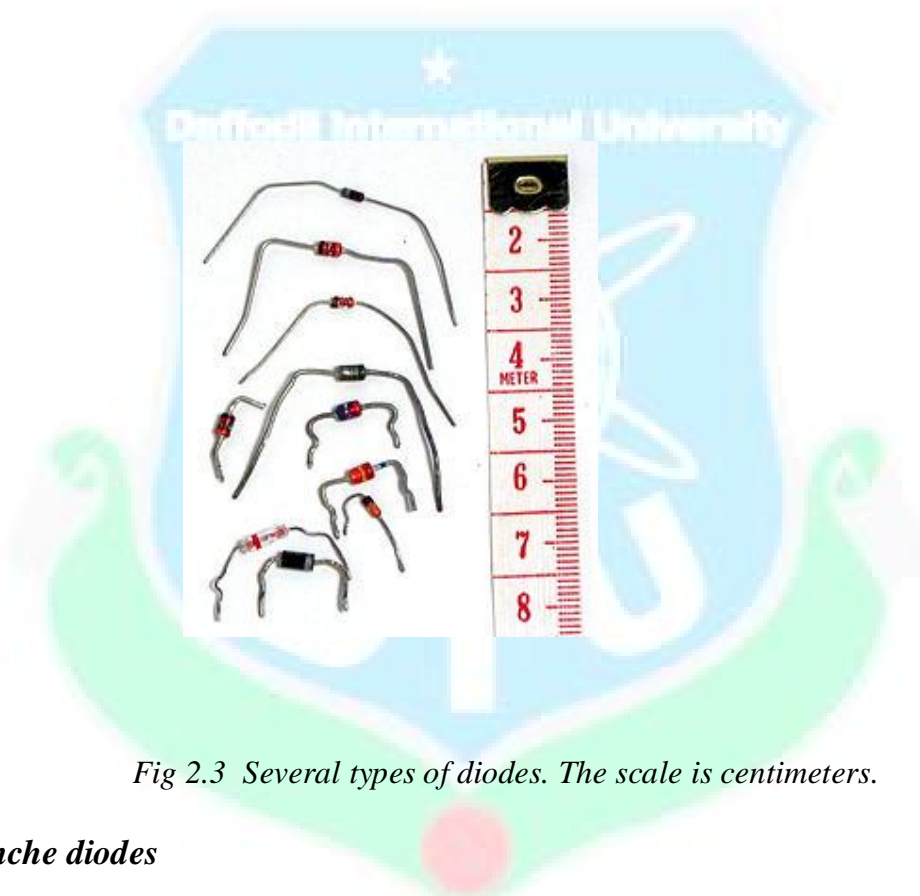

Fig 2.3 Several types of diodes. The scale is centimeters.

Avalanche diodes

Diodes that conduct in the reverse direction when the reverse bias voltage exceeds the breakdown voltage. These are electrically very similar to Zener diodes, and are often mistakenly called Zener diodes, but break down by a different mechanism, the avalanche effect. This occurs when the reverse electric field across the p–n junction causes a wave of ionization, reminiscent of an avalanche, leading to a large current. Avalanche diodes are designed to break down at a well-defined reverse voltage without being destroyed. The difference between the avalanche diode (which has a reverse breakdown above about 6.2 V) and the Zener is that the channel length of the former exceeds the mean free path of the electrons, so there are collisions between

them on the way out. The only practical difference is that the two types have temperature coefficients of opposite polarities.

Cat's whisker or crystal diodes

These are a type of point-contact diode. The cat's whisker diode consists of a thin or sharpened metal wire pressed against a semi conducting crystal, typically galena or a piece of coal. The wire forms the anode and the crystal forms the cathode. Cat's whisker diodes were also called crystal diodes and found application in crystal radio receivers. Cat's whisker diodes are generally obsolete, but may be available from a few manufacturers.

Constant current diodes

These are actually a JFET with the gate shorted to the source, and function like a two-terminal current-limiter analog to the Zener diode, which is limiting voltage. They allow a current through them to rise to a certain value, and then level off at a specific value. Also called CLDs, constant-current diodes, diode-connected transistors, or current-regulating diodes.

Esaki or tunnel diodes

These have a region of operation showing negative resistance caused by quantum tunneling, allowing amplification of signals and very simple bistable circuits. Due to the high carrier concentration, tunnel diodes are very fast, may be used at low (mK) temperatures, high magnetic fields, and in high radiation environments. Because of these properties, they are often used in spacecraft.

Gunn diodes

These are similar to tunnel diodes in that they are made of materials such as GaAs or InP that exhibit a region of negative differential resistance. With appropriate biasing, dipole domains form and travel across the diode, allowing high frequency microwave oscillators to be built.

Light-emitting diodes (LEDs)

In a diode formed from a direct band-gap semiconductor, such as gallium arsenide, carriers that cross the junction emit photons when they recombine with the majority carrier on the other side. Depending on the material, wavelengths (or colors) from the infrared to the near ultraviolet may be produced. The forward potential of these diodes depends on the wavelength of the emitted photons: 2.1 V corresponds to red, 4.0 V to violet. The first LEDs were red and yellow, and higher-frequency diodes have

been developed over time. All LEDs produce incoherent, narrow-spectrum light; "white" LEDs are actually combinations of three LEDs of a different color, or a blue LED with a yellow scintillator coating.

LEDs can also be used as low-efficiency photodiodes in signal applications. An LED may be paired with a photodiode or phototransistor in the same package, to form an opto-isolator.

Laser diodes

When an LED-like structure is contained in a resonant cavity formed by polishing the parallel end faces, a laser can be formed. Laser diodes are commonly used in optical storage devices and for high speed optical communication.

Thermal diodes

This term is used both for conventional p–n diodes used to monitor temperature due to their varying forward voltage with temperature, and for Peltier heat pumps for thermoelectric heating and cooling. Peltier heat pumps may be made from semiconductor, though they do not have any rectifying junctions, they use the differing behaviour of charge carriers in N and P type semiconductor to move heat.

Photodiodes

All semiconductors are subject to optical charge carrier generation. This is typically an undesired effect, so most semiconductors are packaged in light blocking material. Photodiodes are intended to sense light(photo detector), so they are packaged in materials that allow light to pass, and are usually PIN (the kind of diode most sensitive to light). A photodiode can be used in solar cells, in photometry, or in optical communications. Multiple photodiodes may be packaged in a single device, either as a linear array or as a two-dimensional array. These arrays should not be confused with charge-coupled devices.

PIN diodes

A PIN diode has a central un-doped, or intrinsic, layer, forming a p-type/intrinsic/n-type structure. They are used as radio frequency switches and attenuators. They are also used as large volume ionizing radiation detectors and as photo detectors. PIN diodes are also used in power electronics, as their central layer can withstand high voltages. Furthermore, the PIN structure can be found in many power semiconductor devices, such as IGBTs, power MOSFETs, and thyristors.

Schottky diodes

Schottky diodes are constructed from a metal to semiconductor contact. They have a lower forward voltage drop than p–n junction diodes. Their forward voltage drop at forward currents of about 1 mA is in the range 0.15 V to 0.45 V, which makes them useful in voltage clamping applications and prevention of transistor saturation. They can also be used as low loss rectifiers, although their reverse leakage current is in general higher than that of other diodes. Schottky diodes are majority carrier devices and so do not suffer from minority carrier storage problems that slow down many other diodes—so they have a faster reverse recovery than p–n junction diodes. They also tend to have much lower junction capacitance than p–n diodes, which provides for high switching speeds and their use in high-speed circuitry and RF devices such as switched-mode power supply, mixers, and detectors.

Super barrier diodes

Super barrier diodes are rectifier diodes that incorporate the low forward voltage drop of the Schottky diode with the surge-handling capability and low reverse leakage current of a normal p–n junction diode.

Snap-off or Step recovery diodes

The term step recovery relates to the form of the reverse recovery characteristic of these devices. After a forward current has been passing in an SRD and the current is interrupted or reversed, the reverse conduction will cease very abruptly (as in a step waveform). SRDs can, therefore, provide very fast voltage transitions by the very sudden disappearance of the charge carriers.

Stabistors or Forward Reference Diodes

The term stabistor refers to a special type of diodes featuring extremely stable forward voltage characteristics. These devices are specially designed for low-voltage stabilization applications requiring a guaranteed voltage over a wide current range and highly stable over temperature.

Transient voltage suppression diode (TVS)

These are avalanche diodes designed specifically to protect other semiconductor devices from high-voltage transients. Their p–n junctions have a much larger cross-sectional area than those of a normal diode, allowing them to conduct large currents to ground without sustaining damage.

Varicap or varactor diodes

These are used as voltage-controlled capacitors. These are important in PLL (phase-locked loop) and FLL (frequency-locked loop) circuits, allowing tuning circuits, such as those in television receivers, to lock quickly. They also enabled tunable oscillators in early discrete tuning of radios, where a cheap and stable, but fixed-frequency, crystal oscillator provided the reference frequency for a voltage-controlled oscillator.



Chapter-3: Voltage Regulator and transformer

3.1 Voltage Regulator

Voltage Regulator are one of the most important and commonly used electrical component. Voltage Regulators are responsible for maintaining a steady voltage across an Electronic system.

Voltage fluctuations may result in undesirable effect on an electronic system , so to maintaining a steady constant voltage is necessary according to the

voltage requirement of a system.Lets us assume a condition when a simple light emitting diode can take a max of 3 v to the max, what happens if the voltage input exceeds 3v? , of course the diode will burn out .This is also common with all electronic components like, led's , capacitors , diodes etc.... The slightest increase in voltage may result in the failure of entire system by damaging the other components too. For avoiding Damage by such situations voltage regulators are used.

3.2.1 Use IC 7805 voltage Regulator

Voltage regulator IC's are the IC's that are used to regulate voltage.IC 7805 is a 5v Voltage regulator that restricts the voltage output to 5 v. It comes with provision to add heat sink. The maximum value for input to the power / Voltage regulator is 35 v. it can provide a constant steady voltage flow of 5 v for higher voltage input till the threshold limit of 35v. If the voltage is near to 7.5 v then it does not produce any heat and hence no need for heat sinque. If the voltage input is more, then the heat produced is more. It gives steady output if the voltage is in rage of 7.2v to 35 v.

In some circuitry voltage fluctuation is fatal (for e.g. Microcontroller), for such situation to ensure constant voltage IC 7805 Voltage Regulators are used. For more information on specifications of IC 7805 Voltage Regulator please refer the data sheet here (IC 7805 Voltage Regulator Data Sheet)The schematic given below shows how to use an IC-7805. There are 3 pins in IC-7805 ,pin 1 takes the input voltage and pin 3 produces the output voltage. The GND of both input and out are given to pin 2.

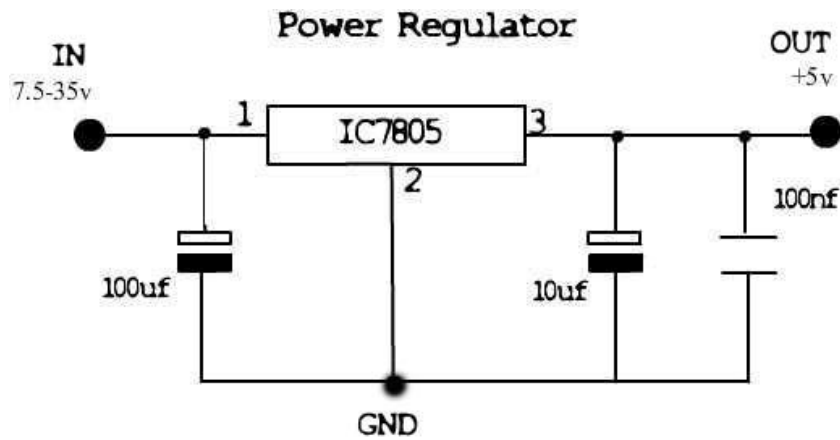
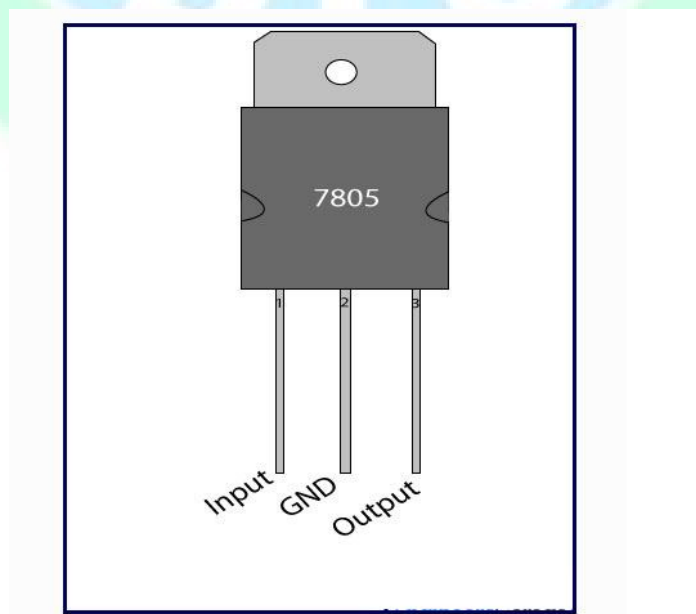

FIG 3.1 VOLTAGE REGULATOR CIRCUIT DIAGRAM

3.2.2 Data sheet:

7805 is a voltage regulator integrated circuit. It is a member of 78xx series of fixed linear voltage regulator ICs. The voltage source in a circuit may have fluctuations and would not give the fixed voltage output. The voltage regulator IC maintains the output voltage at a constant value. The xx in 78xx indicates the fixed output voltage it is designed to provide. 7805 provides +5V regulated power supply. Capacitors of suitable values can be connected at input and output pins depending upon the respective voltage levels.

3.2.3 Pin Diagram:



3.2.4 Pin Description:

Pin No	Function	Name
1	Input voltage (5V-18V)	Input
2	Ground (0V)	Ground
3	Regulated output; 5V (4.8V-5.2V)	Output

3.3 Transformer

The transformer is a device, or a machine, that transfers electrical energy from one electrical circuit to another electrical circuit through the medium of magnetic field and without a change in the frequency. The electric circuit which receives energy from the supply mains is called primary winding and the other circuit which delivers electric energy to the load is called the secondary winding. Actually, the transformer is an electromagnetic energy conversion device. The energy received by the primary is first converted to magnetic energy and it is then reconverted to useful electrical energy in the other circuits (secondary winding circuit, third winding circuit etc.). Thus primary and secondary windings of a transformer are not connected electrically, but are coupled magnetically. This coupling magnetic field allows the transfer of energy in either direction, from high – voltage to low – voltage circuits or from low – voltage to high – voltage circuits. If the transfer of energy occurs at the same voltage, the purpose of the transformer is merely to isolate the two electric circuits and this use is very rare in power applications. If the secondary winding has more turns than the primary winding, then the secondary voltage is higher than the primary winding and the transformer is called a step – up transformer. In case the secondary winding has less turns than the primary winding, then the secondary voltage is lower than the primary voltage and the transformer is called a step – down transformer. A step – up transformer can be used as a step – down transformer, in which the secondary of step – up transformer becomes the primary of step – down transformer. Actually a transformer can be termed a step – up or step – down transformer only after it has been put into service. Therefore, when referring to the windings of a particular transformer, the terms high – voltage winding and low – voltage winding should be used instead of primary and secondary windings.

3.3.1 The Power Transformer

The transformer is either to step-up or step-down the AC supply voltage to suit the requirement of the solid state electronic devices and circuits fed by the DC power supply. One of the important features of a transformer is the electrical isolation

offered between the primary and the secondary. The voltages in the primary and secondary windings are directly proportional to the turn's ratio of the two windings. If V_1 is the voltage applied to the primary, V_2 is voltage induced in the secondary, N_1 is the number of turns in the primary and N_2 is the number of turns in the secondary, then the relationship between them is given by the expression

3.3.2 Turns ratio:

$$\frac{V_1(\text{pri.})}{V_2(\text{sec.})} = \frac{N_1(\text{pri.})}{N_2(\text{sec.})} \dots\dots\dots$$

$$\frac{230V}{24V} = \frac{1380}{N_2}$$

$$230 * N_2 = 1380 * 24$$

$$N_2 = \frac{33120}{230}$$

$$N_2 = 144\text{turns}$$

$$\frac{N_1}{N_2} = \frac{I_2}{I_1} \dots\dots\dots$$

$$\frac{1380}{144} = \frac{1.25}{I_1}$$

$$I_1 = 1.44 * \frac{1.25}{1380}$$

$$I_1 = \frac{180}{1380}$$

$$I_1 = 0.13A$$

$$n = \frac{N_1}{V_1} = \frac{1380}{230} = \frac{6 \text{ turns}}{\text{volts}} \dots\dots\dots$$

$$n = \frac{N_2}{V_2} = \frac{144}{24} = \frac{6\text{turns}}{\text{volts}} \dots\dots\dots$$

3.4 Induction law

The transformer is based on two principles: first, that an electric current can produce a magnetic field and second that a changing magnetic field within a coil of wire induces a voltage across the ends of the coil (electromagnetic induction). Changing the current in the primary coil changes the magnetic flux that is developed. The changing magnetic flux induces a voltage in the secondary coil.

Referring to the two figures here, current passing through the primary coil creates a magnetic field. The primary and secondary coils are wrapped around a core of very high magnetic permeability, usually iron, so that most of the magnetic flux passes through both the primary and secondary coils. Any secondary winding connected load causes current and voltage induction from primary to secondary circuits in indicated directions. The voltage induced across the secondary coil may be calculated from Faraday's law of induction, which states that:

where $V_s = E_s$ is the instantaneous voltage, N_s is the number of turns in the secondary coil, and $d\Phi/dt$ is the derivative of the magnetic flux Φ through one turn of the coil. If the turns of the coil are oriented perpendicularly to the magnetic field lines, the flux is the product of the magnetic flux density B and the area A through which it cuts. The area is constant, being equal to the cross-sectional area of the transformer core, whereas the magnetic field varies with time according to the excitation of the primary. Since the same magnetic flux passes through both the primary and secondary coils in an ideal transformer, the instantaneous voltage across the primary winding equals

$$V_P = E_P = N_P \frac{d\Phi}{dt}$$

Taking the ratio of the above two equations gives the same voltage ratio and turns ratio relationship shown above, that is,

$$\frac{V_P}{V_S} = \frac{E_P}{E_S} = \frac{N_P}{N_S} = a$$

The changing magnetic field induces an emf across each winding. The primary emf, acting as it does in opposition to the primary voltage, is sometimes termed the counter

emf. This is in accordance with Lenz's law, which states that induction of emf always opposes development of any such change in magnetic field.

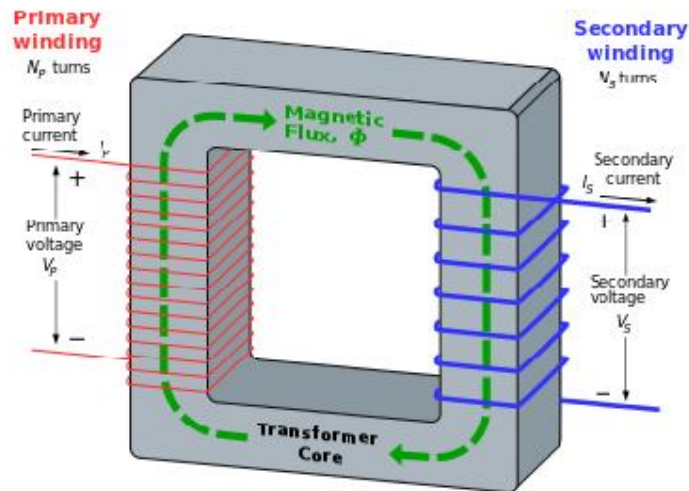

FIG 3.3

3.4.1 Leakage flux

The ideal transformer model assumes that all flux generated by the primary winding links all the turns of every winding, including itself. In practice, some flux traverses paths that take it outside the windings. Such flux is termed leakage flux, and results in leakage inductance in series with the mutually coupled transformer windings. Leakage flux results in energy being alternately stored in and discharged from the magnetic fields with each cycle of the power supply. It is not directly a power loss (see Stray losses below), but results in inferior voltage regulation, causing the secondary voltage to not be directly proportional to the primary voltage, particularly under heavy load. Transformers are therefore normally designed to have very low leakage inductance. Nevertheless, it is impossible to eliminate all leakage flux because it plays an essential part in the operation of the transformer. The combined effect of the leakage flux and the electric field around the windings is what transfers energy from the primary to the secondary.

In some applications increased leakage is desired, and long magnetic paths, air gaps, or magnetic bypass shunts may deliberately be introduced in a transformer design to

limit the short-circuit current it will supply. Leaky transformers may be used to supply loads that exhibit negative resistance, such as electric arcs, mercury vapor lamps, and neon signs or for safely handling loads that become periodically short-circuited such as electric arc welders.

Air gaps are also used to keep a transformer from saturating, especially audio-frequency transformers in circuits that have a DC component flowing through the windings.

Knowledge of leakage inductance is for example useful when transformers are operated in parallel. It can be shown that if the percent impedance (Z) and associated winding leakage reactance-to-resistance (X/R) ratio of two transformers were hypothetically exactly the same, the transformers would share power in proportion to their respective volt-ampere ratings (e.g. 500 kVA unit in parallel with 1,000 kVA unit, the larger unit would carry twice the current).

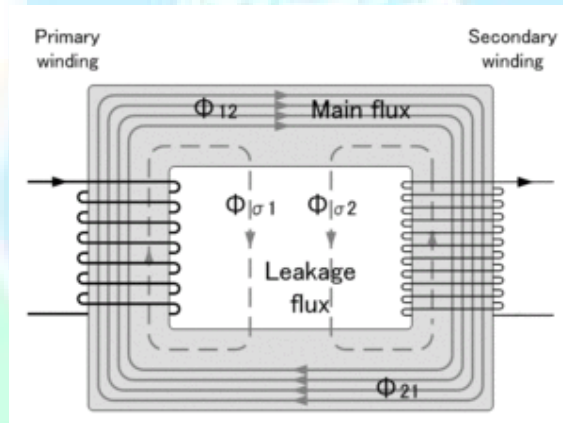

Fig 3.4(Leakage flux)

Chapter- 4 Rectifier

4.1 Rectifier

A rectifier is an electrical device that converts alternating current (AC), which periodically reverses direction, to direct current (DC), which flows in only one direction. The process is known as rectification. Physically, rectifiers take a number of forms, including vacuum tube diodes, mercury-arc valves, copper and selenium oxide rectifiers, semiconductor diodes, silicon-controlled rectifiers and other silicon-based semiconductor switches. Historically, even synchronous electromechanical switches and motors have been used. Early radio receivers, called crystal radios, used a "cat's whisker" of fine wire pressing on a crystal of galena (lead sulfide) to serve as a point-contact rectifier or "crystal detector".

Rectifiers have many uses, but are often found serving as components of DC power supplies and high-voltage direct current power transmission systems. Rectification may serve in roles other than to generate direct current for use as a source of power. As noted, detectors of radio signals serve as rectifiers. In gas heating systems flame rectification is used to detect presence of flame.

The simple process of rectification produces a type of DC characterized by pulsating voltages and currents (although still unidirectional). Depending upon the type of end-use, this type of DC current may then be further modified into the type of relatively constant voltage DC characteristically produced by such sources as batteries and solar cells.

A more complex circuitry device which performs the opposite function, converting DC to AC, is known as an inverter.

4.2 The Full Wave Rectifier

In the previous Power Diodes tutorial we discussed ways of reducing the ripple or voltage variations on a direct DC voltage by connecting capacitors across the load resistance. While this method may be suitable for low power applications it is unsuitable to applications which need a "steady and smooth" DC supply voltage. One method to improve on this is to use every half-cycle of the input voltage instead of every other half-cycle. The circuit which allows us to do this is called a Full Wave Rectifier.

Like the half wave circuit, a full wave rectifier circuit produces an output voltage or current which is purely DC or has some specified DC component. Full wave rectifiers have some fundamental advantages over their half wave rectifier counterparts. The

average (DC) output voltage is higher than for half wave, the output of the full wave rectifier has much less ripple than that of the half wave rectifier producing a smoother output waveform.

In a Full Wave Rectifier circuit two diodes are now used, one for each half of the cycle. A multiple winding transformer is used whose secondary winding is split equally into two halves with a common centre tapped connection, (C). This configuration results in each diode conducting in turn when its anode terminal is positive with respect to the transformer centre point C producing an output during both half-cycles, twice that for the half wave rectifier so it is 100% efficient as shown below

4.3 Full Wave Rectifier Circuit

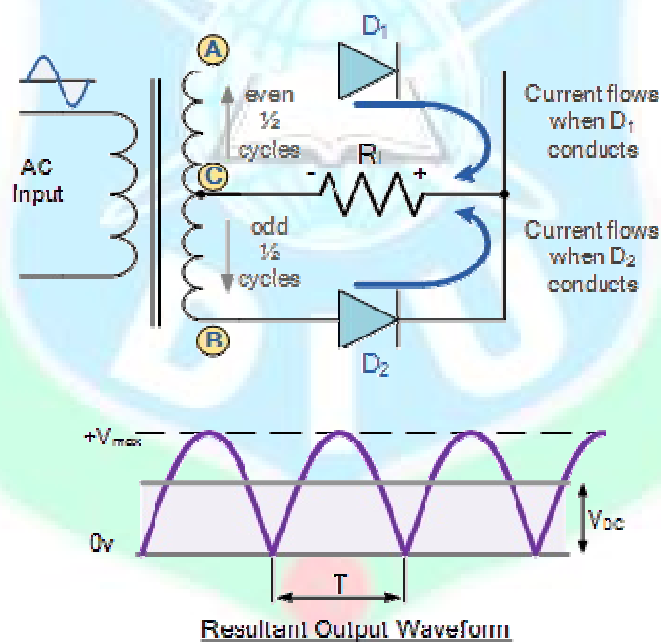

Fig 4.1(Full Wave Rectifier)

The full wave rectifier circuit consists of two power diodes connected to a single load resistance (R_L) with each diode taking it in turn to supply current to the load. When point A of the transformer is positive with respect to point C, diode D_1 conducts in the forward direction as indicated by the arrows. When point B is positive (in the negative half of the cycle) with respect to point C, diode D_2 conducts in the forward direction

and the current flowing through resistor R is in the same direction for both half-cycles. As the output voltage across the resistor R is the phasor sum of the two waveforms combined, this type of full wave rectifier circuit is also known as a "bi-phase" circuit.

As the spaces between each half-wave developed by each diode is now being filled in by the other diode the average DC output voltage across the load resistor is now double that of the single half-wave rectifier circuit and is about $0.637V_{max}$ of the peak voltage, assuming no losses.

$$V_{d.c.} = \frac{2V_{max}}{\pi} = 0.637V_{max} = 0.9V_{RMS}$$

Where: V_{MAX} is the maximum peak value in one half of the secondary winding and V_{RMS} is the rms value.

The peak voltage of the output waveform is the same as before for the half-wave rectifier provided each half of the transformer windings have the same rms voltage value. To obtain a different DC voltage output different transformer ratios can be used. The main disadvantage of this type of full wave rectifier circuit is that a larger transformer for a given power output is required with two separate but identical secondary windings making this type of full wave rectifying circuit costly compared to the "Full Wave Bridge Rectifier" circuit equivalent.

4.4 The Full Wave Bridge Rectifier

Another type of circuit that produces the same output waveform as the full wave rectifier circuit above, is that of the Full Wave Bridge Rectifier. This type of single phase rectifier uses four individual rectifying diodes connected in a closed loop "bridge" configuration to produce the desired output. The main advantage of this bridge circuit is that it does not require a special centre tapped transformer, thereby reducing its size and cost. The single secondary winding is connected to one side of the diode bridge network and the load to the other side as shown below.

4.5 The Diode Bridge Rectifier

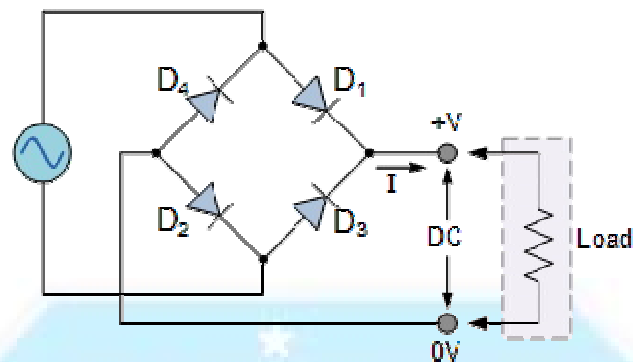

Fig 4.2 (Bridge Rectifier)

The four diodes labelled D1 to D4 are arranged in "series pairs" with only two diodes conducting current during each half cycle. During the positive half cycle of the supply, diodes D1 and D2 conduct in series while diodes D3 and D4 are reverse biased and the current flows through the load as shown below.

4.5.1 The Positive Half-cycle

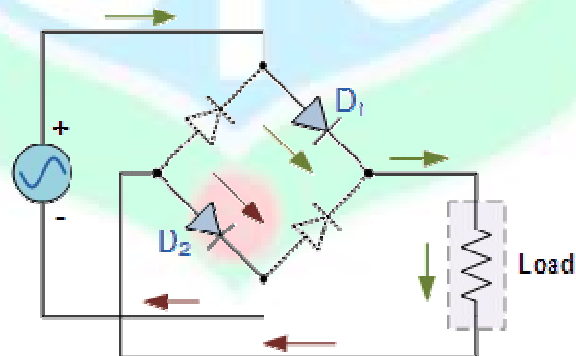

Fig 4.3 (Positive Half-cycle)

4.5.1 Positive Half-cycle

During the negative half cycle of the supply, diodes D_3 and D_4 conduct in series, but diodes D_1 and D_2 switch "OFF" as they are now reverse biased. The current flowing through the load is the same direction as before.

4.5.2 The Negative Half-cycle

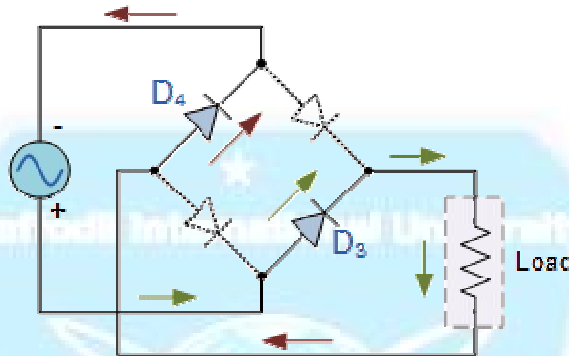

Fig 4.4 (Negative Half-cycle)

As the current flowing through the load is unidirectional, so the voltage developed across the load is also unidirectional the same as for the previous two diode full-wave rectifier, therefore the average DC voltage across the load is $0.637V_{max}$. However in reality, during each half cycle the current flows through two diodes instead of just one so the amplitude of the output voltage is two voltage drops ($2 \times 0.7 = 1.4V$) less than the input V_{MAX} amplitude. The ripple frequency is now twice the supply frequency (e.g. 100Hz for a 50Hz supply)

Although we can use four individual power diodes to make a full wave bridge rectifier, pre-made bridge rectifier components are available "off-the-shelf" in a range of different voltage and current sizes that can be soldered directly into a PCB circuit board or be connected by spade connectors.

The image to the right shows a typical single phase bridge rectifier with one corner cut off. This cut-off corner indicates that the terminal nearest to the corner is the positive or +ve output terminal or lead with the opposite (diagonal) lead being the negative or -ve output lead. The other two connecting leads are for the input alternating voltage from a transformer secondary winding.

4.6 The Smoothing Capacitor

We saw in the previous section that the single phase half-wave rectifier produces an output wave every half cycle and that it was not practical to use this type of circuit to

produce a steady DC supply. The full-wave bridge rectifier however, gives us a greater mean DC value ($0.637 V_{max}$) with less superimposed ripple while the output waveform is twice that of the frequency of the input supply frequency. We can therefore increase its average DC output level even higher by connecting a suitable smoothing capacitor across the output of the bridge circuit as shown below.

4.7 Full-wave Rectifier with Smoothing Capacitor

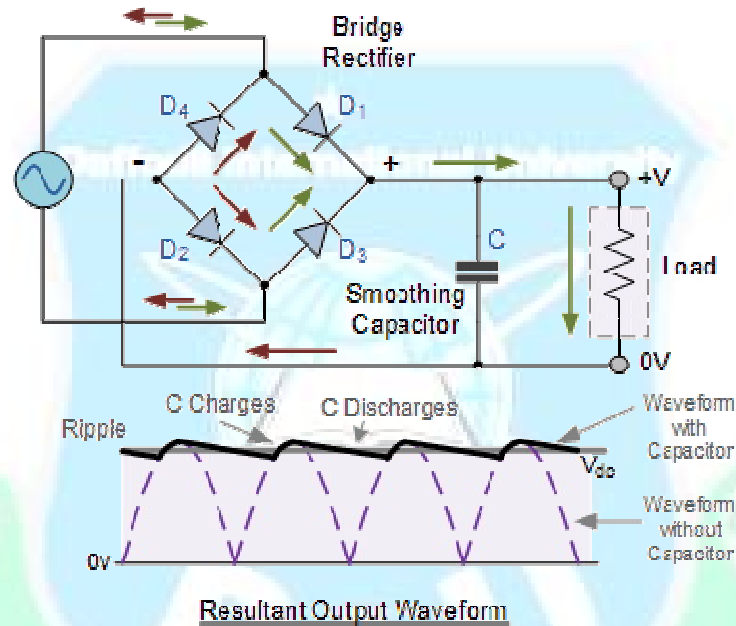

Fig 4.5 (Full-wave Rectifier with Smoothing Capacitor)

The smoothing capacitor converts the full-wave rippled output of the rectifier into a smooth DC output voltage. Generally for DC power supply circuits the smoothing capacitor is an Aluminium Electrolytic type that has a capacitance value of $100\mu\text{F}$ or more with repeated DC voltage pulses from the rectifier charging up the capacitor to peak voltage. However, there are two important parameters to consider when choosing a suitable smoothing capacitor and these are its Working Voltage, which must be higher than the no-load output value of the rectifier and its Capacitance Value, which determines the amount of ripple that will appear superimposed on top of the DC voltage.

Too low a capacitance value and the capacitor has little effect on the output waveform. But if the smoothing capacitor is sufficiently large enough (parallel

capacitors can be used) and the load current is not too large, the output voltage will be almost as smooth as pure DC. As a general rule of thumb, we are looking to have a ripple voltage of less than 100mV peak to peak.

The maximum ripple voltage present for a Full Wave Rectifier circuit is not only determined by the value of the smoothing capacitor but by the frequency and load current, and is calculated as:

Bridge Rectifier Ripple Voltage

$$V_{\text{RIPPLE}} = \frac{I_{\text{LOAD}}}{fC} \text{ volts}$$

Where: I is the DC load current in amps, f is the frequency of the ripple or twice the input frequency in Hertz, and C is the capacitance in Farads.

The main advantages of a full-wave bridge rectifier is that it has a smaller AC ripple value for a given load and a smaller reservoir or smoothing capacitor than an equivalent half-wave rectifier. Therefore, the fundamental frequency of the ripple voltage is twice that of the AC supply frequency (100Hz) where for the half-wave rectifier it is exactly equal to the supply frequency (50Hz).

The amount of ripple voltage that is superimposed on top of the DC supply voltage by the diodes can be virtually eliminated by adding a much improved π -filter (pi-filter) to the output terminals of the bridge rectifier. This type of low-pass filter consists of two smoothing capacitors, usually of the same value and a choke or inductance across them to introduce a high impedance path to the alternating ripple component.

Another more practical and cheaper alternative is to use an off the shelf 3-terminal voltage regulator IC, such as a LM78xx (where "xx" stands for the output voltage rating) for a positive output voltage or its inverse equivalent the LM79xx for a negative output voltage which can reduce the ripple by more than 70dB (Datasheet) while delivering a constant output current of over 1 amp.

In the next tutorial about diodes, we will look at the Zener Diode which takes advantage of its reverse breakdown voltage characteristic to produce a constant and fixed output voltage across itself.

Chapter- 5 Capacitor

5.1 Capacitor

A capacitor (originally known as a condenser) is a passive two-terminal electrical component used to store energy electrostatically in an electric field. The forms of practical capacitors vary widely, but all contain at least two electrical conductors separated by a dielectric (insulator); for example, one common construction consists of metal foils separated by a thin layer of insulating film. Capacitors are widely used as parts of electrical circuits in many common electrical devices.

When there is a potential difference (voltage) across the conductors, a static electric field develops across the dielectric, causing positive charge to collect on one plate and negative charge on the other plate. Energy is stored in the electrostatic field. An ideal capacitor is characterized by a single constant value, capacitance. This is the ratio of the electric charge on each conductor to the potential difference between them. The SI unit of capacitance is the farad, which is equal to one coulomb per volt.

The capacitance is greatest when there is a narrow separation between large areas of conductor, hence capacitor conductors are often called plates, referring to an early means of construction. In practice, the dielectric between the plates passes a small amount of leakage current and also has an electric field strength limit, the breakdown voltage. The conductors and leads introduce an undesired inductance and resistance.

Capacitors are widely used in electronic circuits for blocking direct current while allowing alternating current to pass. In analog filter networks, they smooth the output of power supplies. In resonant circuits they tune radios to particular frequencies. In electric power transmission systems they stabilize voltage and power flow.



5.2 History

October 1745, Ewald Georg von Kleist of Pomeranian in Germany found that charge could be stored by connecting a high-voltage electrostatic generator by a wire to a volume of water in a hand-held glass jar. Von Kleist's hand and the water acted as conductors, and the jar as a dielectric (although details of the mechanism were incorrectly identified at the time). Von Kleist found that touching the wire resulted in a powerful spark, much more painful than that obtained from an electrostatic machine. The following year, the Dutch physicist Pieter van Musschenbroek invented a similar capacitor, which was named the Leyden jar, after the University of Leiden where he worked. He also was impressed by the power of the shock he received, writing, "I would not take a second shock for the kingdom of France."

Daniel Galvani was the first to combine several jars in parallel into a "battery" to increase the charge storage capacity. Benjamin Franklin investigated the Leyden jar and came to the conclusion that the charge was stored on the glass, not in the water as others had assumed. He also adopted the term "battery", (denoting the increasing of power with a row of similar units as in a battery of cannon), subsequently applied to clusters of electrochemical cells. Leyden jars were later made by coating the inside and outside of jars with metal foil, leaving a space at the mouth to prevent arcing between the foils. The earliest unit of capacitance was the jar, equivalent to about 1 nanofarad.

Leyden jars or more powerful devices employing flat glass plates alternating with foil conductors were used exclusively up until about 1900, when the invention of wireless (radio) created a demand for standard capacitors, and the steady move to higher frequencies required capacitors with lower inductance. A more compact construction began to be used of a flexible dielectric sheet such as oiled paper sandwiched between sheets of metal foil, rolled or folded into a small package.

Early capacitors were also known as condensers, a term that is still occasionally used today. The term was first used for this purpose by Alessandro Volta in 1782, with reference to the device's ability to store a higher density of electric charge than a normal isolated conductor.

5.3 Theory of operation

A capacitor consists of two conductors separated by a non-conductive region. The non-conductive region is called the dielectric. In simpler terms, the dielectric is just an electrical insulator. Examples of dielectric media are glass, air, paper, vacuum, and even a semiconductor depletion region chemically identical to the conductors. A

capacitor is assumed to be self-contained and isolated, with no net electric charge and no influence from any external electric field. The conductors thus hold equal and opposite charges on their facing surfaces, and the dielectric develops an electric field. In SI units, a capacitance of one farad means that one coulomb of charge on each conductor causes a voltage of one volt across the device.

An ideal capacitor is wholly characterized by a constant capacitance C , defined as the ratio of charge $\pm Q$ on each conductor to the voltage V between them.

$$C = \frac{Q}{V}$$

Because the conductors (or plates) are close together, the opposite charges on the conductors attract one another due to their electric fields, allowing the capacitor to store more charge for a given voltage than if the conductors were separated, giving the capacitor a large capacitance.

Sometimes charge build-up affects the capacitor mechanically, causing its capacitance to vary. In this case, capacitance is defined in terms of incremental changes:

$$C = \frac{dQ}{dV}$$

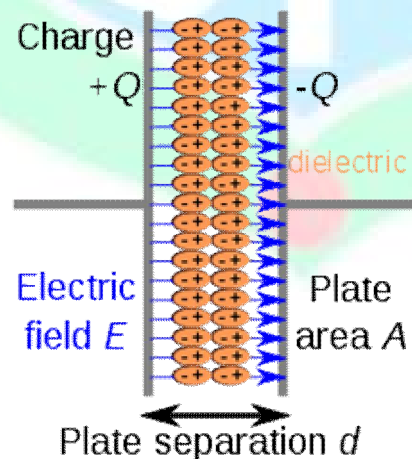

5.4 Hydraulic analogy

In the hydraulic analogy, a capacitor is analogous to a rubber membrane sealed inside a pipe. This animation illustrates a membrane being repeatedly stretched and un-stretched by the flow of water, which is analogous to a capacitor being repeatedly charged and discharged by the flow of charge.

In the hydraulic analogy, charge carriers flowing through a wire are analogous to water flowing through a pipe. A capacitor is like a rubber membrane sealed inside a pipe. Water molecules cannot pass through the membrane, but some water can move by stretching the membrane. The analogy clarifies a few aspects of capacitors:

- The current alters the charge on a capacitor, just as the flow of water changes the position of the membrane. More specifically, the effect of an electric current is to increase the charge of one plate of the capacitor, and decrease the charge of the other plate by an equal amount. This is just like how, when water flow moves the rubber membrane, it increases the amount of water on one side of the membrane, and decreases the amount of water on the other side.*
- The more a capacitor is charged, the larger its voltage drop; i.e., the more it "pushes back" against the charging current. This is analogous to the fact that the more a membrane is stretched, the more it pushes back on the water.*
- Charge can flow "through" a capacitor even though no individual electron can get from one side to the other. This is analogous to the fact that water can flow through the pipe even though no water molecule can pass through the rubber membrane. Of course, the flow cannot continue the same direction forever; the capacitor will experience dielectric breakdown, and analogously the membrane will eventually break.*
- The capacitance describes how much charge can be stored on one plate of a capacitor for a given "push" (voltage drop). A very stretchy, flexible membrane corresponds to a higher capacitance than a stiff membrane.*
- A charged-up capacitor is storing potential energy, analogously to a stretched membrane.*

5.5 Energy of electric field

Work must be done by an external influence to "move" charge between the conductors in a capacitor. When the external influence is removed, the charge separation persists in the electric field and energy is stored to be released when the charge is allowed to return to its equilibrium position. The work done in establishing the electric field, and hence the amount of energy stored, is

$$W = \int_0^Q V dq = \int_0^Q \frac{q}{C} dq = \frac{1}{2} \frac{Q^2}{C} = \frac{1}{2} CV^2 = \frac{1}{2} VQ$$

Here Q is the charge stored in the capacitor, V is the voltage across the capacitor, and C is the capacitance.

In the case of a fluctuating voltage $V(t)$, the stored energy also fluctuates and hence power must flow into or out of the capacitor. This power can be found by taking the time derivative of the stored energy:

$$P = \frac{dW}{dt} = \frac{d}{dt} \left(\frac{1}{2} CV^2 \right) = CV(t) \frac{dV}{dt}$$

5.6 Current–voltage relation

The current $I(t)$ through any component in an electric circuit is defined as the rate of flow of a charge $Q(t)$ passing through it, but actual charges—electrons—cannot pass through the dielectric layer of a capacitor. Rather, an electron accumulates on the negative plate for each one that leaves the positive plate, resulting in an electron depletion and consequent positive charge on one electrode that is equal and opposite to the accumulated negative charge on the other. Thus the charge on the electrodes is equal to the integral of the current as well as proportional to the voltage, as discussed above. As with any antiderivative, a constant of integration is added to represent the initial voltage $V(t_0)$. This is the integral form of the capacitor equation.

$$V(t) = \frac{Q(t)}{C} = \frac{1}{C} \int_{t_0}^t I(\tau) d\tau + V(t_0)$$

Taking the derivative of this and multiplying by C yields the derivative form

$$I(t) = \frac{dQ(t)}{dt} = C \frac{dV(t)}{dt}$$

The dual of the capacitor is the inductor, which stores energy in a magnetic field rather than an electric field. Its current-voltage relation is obtained by exchanging current and voltage in the capacitor equations and replacing C with the inductance L .

5.6.1 DC circuits

See also: RC circuit

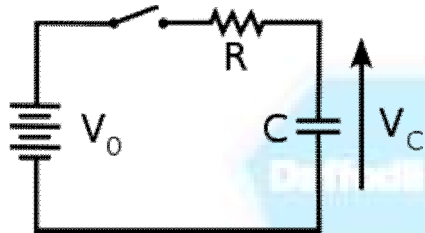

A simple resistor-capacitor circuit demonstrates charging of a capacitor.

A series circuit containing only a resistor, a capacitor, a switch and a constant DC source of voltage V_0 is known as a charging circuit. If the capacitor is initially uncharged while the switch is open, and the switch is closed at t_0 , it follows from Kirchhoff's voltage law that

$$V_0 = v_{\text{resistor}}(t) + v_{\text{capacitor}}(t) = i(t)R + \frac{1}{C} \int_{t_0}^t i(\tau) d\tau$$

Taking the derivative and multiplying by C , gives a first-order differential equation:

$$RC \frac{di(t)}{dt} + i(t) = 0$$

At $t = 0$, the voltage across the capacitor is zero and the voltage across the resistor is V_0 . The initial current is then $I(0) = V_0/R$. With this assumption, solving the differential equation yields

$$I(t) = \frac{V_0}{R} e^{-\frac{t}{\tau_0}}$$

$$V(t) = V_0 \left(1 - e^{-\frac{t}{\tau_0}}\right)$$

where $\tau_0 = RC$ is the time constant of the system. As the capacitor reaches equilibrium with the source voltage, the voltages across the resistor and the current through the entire circuit decay exponentially. The case of discharging a charged capacitor likewise demonstrates exponential decay, but with the initial capacitor voltage replacing V_0 and the final voltage being zero.

5.6.2 AC circuits

See also: reactance (electronics) and electrical impedance. Deriving the device specific impedances

Impedance, the vector sum of reactance and resistance, describes the phase difference and the ratio of amplitudes between sinusoidally varying voltage and sinusoidally varying current at a given frequency. Fourier analysis allows any signal to be constructed from a spectrum of frequencies, whence the circuit's reaction to the various frequencies may be found. The reactance and impedance of a capacitor are respectively

$$X = -\frac{1}{\omega C} = -\frac{1}{2\pi f C}$$

$$Z = \frac{1}{j\omega C} = -\frac{j}{\omega C} = -\frac{j}{2\pi f C}$$

where j is the imaginary unit and ω is the angular frequency of the sinusoidal signal. The $-j$ phase indicates that the AC voltage $V = ZI$ lags the AC current by 90° : the positive current phase corresponds to increasing voltage as the capacitor charges; zero current corresponds to instantaneous constant voltage, etc.

Impedance decreases with increasing capacitance and increasing frequency. This implies that a higher-frequency signal or a larger capacitor results in a lower voltage amplitude per current amplitude—an AC "short circuit" or AC coupling. Conversely, for very low frequencies, the reactance will be high, so that a capacitor is nearly an open circuit in AC analysis those frequencies have been "filtered out". Capacitors are different from resistors and inductors in that the impedance is inversely proportional to the defining characteristic; i.e., capacitance.

5.7 Capacitor types

Main article: Types of capacitor

Practical capacitors are available commercially in many different forms. The type of internal dielectric, the structure of the plates and the device packaging all strongly affect the characteristics of the capacitor, and its applications.

Values available range from very low (picofarad range; while arbitrarily low values are in principle possible, stray (parasitic) capacitance in any circuit is the limiting factor) to about 5 kF supercapacitors.

Above approximately 1 microfarad electrolytic capacitors are usually used because of their small size and low cost compared with other technologies, unless their relatively poor stability, life and polarised nature make them unsuitable. Very high capacity supercapacitors use a porous carbon-based electrode material.

5.8 Dielectric materials



Capacitor materials. From left: multilayer ceramic, ceramic disc, multilayer polyester film, tubular ceramic, polystyrene, metalized polyester film, aluminum electrolytic. Major scale divisions are in centimetres.

Most types of capacitor include a dielectric spacer, which increases their capacitance. These dielectrics are most often insulators. However, low capacitance devices are available with a vacuum between their plates, which allows extremely high voltage operation and low losses. Variable capacitors with their plates open to the atmosphere were commonly used in radio tuning circuits. Later designs use polymer foil dielectric between the moving and stationary plates, with no significant air space between them.

In order to maximize the charge that a capacitor can hold, the dielectric material needs to have as high a permittivity as possible, while also having as high a breakdown voltage as possible.

Several solid dielectrics are available, including paper, plastic, glass, mica and ceramic materials. Paper was used extensively in older devices and offers relatively high voltage performance. However, it is susceptible to water absorption, and has been largely replaced by plastic film capacitors. Plastics offer better stability and aging performance, which makes them useful in timer circuits, although they may be limited to low operating temperatures and frequencies. Ceramic capacitors are generally small, cheap and useful for high frequency applications, although their capacitance varies strongly with voltage and they age poorly. They are broadly categorized as class 1 dielectrics, which have predictable variation of capacitance with temperature or class 2 dielectrics, which can operate at higher voltage. Glass and mica capacitors are extremely reliable, stable and tolerant to high temperatures and voltages, but are too expensive for most mainstream applications. Electrolytic capacitors and supercapacitors are used to store small and larger amounts of energy, respectively, ceramic capacitors are often used in resonators, and parasitic capacitance occurs in circuits wherever the simple conductor-insulator-conductor structure is formed unintentionally by the configuration of the circuit layout.

Electrolytic capacitors use an aluminum or tantalum plate with an oxide dielectric layer. The second electrode is a liquid electrolyte, connected to the circuit by another foil plate. Electrolytic capacitors offer very high capacitance but suffer from poor tolerances, high instability, gradual loss of capacitance especially when subjected to heat, and high leakage current. Poor quality capacitors may leak electrolyte, which is harmful to printed circuit boards. The conductivity of the electrolyte drops at low temperatures, which increases equivalent series resistance. While widely used for power-supply conditioning, poor high-frequency characteristics make them unsuitable for many applications. Electrolytic capacitors will self-degrade if unused for a period (around a year), and when full power is applied may short circuit, permanently damaging the capacitor and usually blowing a fuse or causing failure of rectifier diodes (for instance, in older equipment, arcing in rectifier tubes). They can be restored before use (and damage) by gradually applying the operating voltage, often done on antique vacuum tube equipment over a period of 30 minutes by using a variable transformer to supply AC power. Unfortunately, the use of this technique may be less satisfactory for some solid state equipment, which may be damaged by operation below its normal power range, requiring that the power supply first be isolated from the consuming circuits. Such remedies may not be applicable to modern high-frequency power supplies as these produce full output voltage even with reduced input.

Tantalum capacitors offer better frequency and temperature characteristics than aluminum, but higher dielectric absorption and leakage.

Polymer capacitors (OS-CON, OC-CON, KO, AO) use solid conductive polymer (or polymerized organic semiconductor) as electrolyte and offer longer life and lower ESR at higher cost than standard electrolytic capacitors.

A Feedthrough is a component that, while not serving as its main use, has capacitance and is used to conduct signals through a circuit board.

Several other types of capacitor are available for specialist applications. Supercapacitors store large amounts of energy. Supercapacitors made from carbon aerogel, carbon nanotubes, or highly porous electrode materials, offer extremely high capacitance (up to 5 kF as of 2010) and can be used in some applications instead of rechargeable batteries. Alternating current capacitors are specifically designed to work on line (mains) voltage AC power circuits. They are commonly used in electric motor circuits and are often designed to handle large currents, so they tend to be physically large. They are usually ruggedly packaged, often in metal cases that can be easily grounded/earthed. They also are designed with direct current breakdown voltages of at least five times the maximum AC voltage.

5.9 Structure



Capacitor packages: SMD ceramic at top left; SMD tantalum at bottom left; through-hole tantalum at top right; through-hole electrolytic at bottom right. Major scale divisions are cm.

The arrangement of plates and dielectric has many variations depending on the desired ratings of the capacitor. For small values of capacitance (microfarads and less), ceramic disks use metallic coatings, with wire leads bonded to the coating. Larger values can be made by multiple stacks of plates and disks. Larger value capacitors usually use a metal foil or metal film layer deposited on the surface of a

dielectric film to make the plates, and a dielectric film of impregnated paper or plastic – these are rolled up to save space. To reduce the series resistance and inductance for long plates, the plates and dielectric are staggered so that connection is made at the common edge of the rolled-up plates, not at the ends of the foil or metalized film strips that comprise the plates.

The assembly is encased to prevent moisture entering the dielectric – early radio equipment used a cardboard tube sealed with wax. Modern paper or film dielectric capacitors are dipped in a hard thermoplastic. Large capacitors for high-voltage use may have the roll form compressed to fit into a rectangular metal case, with bolted terminals and bushings for connections. The dielectric in larger capacitors is often impregnated with a liquid to improve its properties.



Several axial-lead electrolytic capacitors

Capacitors may have their connecting leads arranged in many configurations, for example axially or radially. "Axial" means that the leads are on a common axis, typically the axis of the capacitor's cylindrical body – the leads extend from opposite ends. Radial leads might more accurately be referred to as tandem; they are rarely actually aligned along radii of the body's circle, so the term is inexact, although universal. The leads (until bent) are usually in planes parallel to that of the flat body of the capacitor, and extend in the same direction; they are often parallel as manufactured.

Small, cheap discoidal ceramic capacitors have existed since the 1930s, and remain in widespread use. Since the 1980s, surface mount packages for capacitors have been widely used. These packages are extremely small and lack connecting leads, allowing them to be soldered directly onto the surface of printed circuit boards. Surface mount components avoid undesirable high-frequency effects due to the leads and simplify

automated assembly, although manual handling is made difficult due to their small size.

Mechanically controlled variable capacitors allow the plate spacing to be adjusted, for example by rotating or sliding a set of movable plates into alignment with a set of stationary plates. Low cost variable capacitors squeeze together alternating layers of aluminum and plastic with a screw. Electrical control of capacitance is achievable with varactors (or varicaps), which are reverse-biased semiconductor diodes whose depletion region width varies with applied voltage. They are used in phase-locked loops, amongst other applications.

5.10 Capacitor markings

Most capacitors have numbers printed on their bodies to indicate their electrical characteristics. Larger capacitors like electrolytics usually display the actual capacitance together with the unit (for example, 220 μF). Smaller capacitors like ceramics, however, use a shorthand consisting of three numbers and a letter, where the numbers show the capacitance in pF (calculated as $XY \times 10^Z$ for the numbers XYZ) and the letter indicates the tolerance (J, K or M for $\pm 5\%$, $\pm 10\%$ and $\pm 20\%$ respectively).

Additionally, the capacitor may show its working voltage, temperature and other relevant characteristics.

Chapter- 6 Cost Analysis

6.1 Cost Sheet Table

<i>Name</i>	<i>Model/Value</i>	<i>Quantity</i>	<i>Purchase Price TK</i>
<i>Transformer</i>	<i>China</i>	<i>1</i>	<i>180</i>
<i>Diode</i>	<i>N4007</i>	<i>7</i>	<i>14</i>
<i>Capacitor</i>	<i>2200μF</i>		<i>20</i>
<i>Capacitor</i>	<i>100μF</i>	<i>1</i>	<i>10</i>
<i>Battery</i>	<i>12V 7.5</i>	<i>1</i>	<i>1300</i>
<i>Voltage regulator</i>	<i>L7805CV</i>	<i>1</i>	<i>15</i>
<i>Voltage regulator</i>	<i>L78012CV</i>	<i>1</i>	<i>15</i>
<i>Resistance</i>	<i>200Ω</i>	<i>1</i>	<i>2</i>
<i>Resistance</i>	<i>1KΩ</i>	<i>1</i>	<i>4</i>
<i>LED</i>			<i>10</i>
<i>Board</i>		<i>1</i>	<i>30</i>
<i>Caching</i>		<i>1</i>	<i>260</i>
<i>Switch</i>		<i>2</i>	<i>50</i>
<i>Input Jack</i>		<i>1</i>	<i>30</i>
<i>Output Jack</i>		<i>2</i>	<i>60</i>
<i>Other</i>			<i>500</i>

		<i>Total</i>	2500
--	--	--------------	------

6.2 Cost comparison:

The available ac to dc converter available in market are high pricing where as our designed ac to dc converter is the cheapest one. We have experiment in the market before our marketing project. There are many AC to DC converters which are sold till TK 3000-3500

At first, we select a circuit diagram then we make a chart of electronic device according to that diagram. We use a step down transformer 220V/12V, seven diodes, a LED, a Battery, three capacitors, two resistor, a board, which value of market is TK.2000, including other cost we have paid TK.2500 for completing the project.

6.3 Conclusion:

This project report is AC to DC converter that can deliver 12V. Unregulated and 5V regulated DC. The transformer T1 steps down the mains voltage to 12V AC and then the bridge B1 rectifies it. The rectified signal is smoothed by the capacitor C1. When the mains supply is available the battery will be charged via diode D3 and the regulator IC gets supply via diode D5. 12V and 5V DC will be available at the output terminals. When mains supply is not available the battery supplies current to the regulator IC and to the 12V DC terminal through diode D4. Also, the diode D3 blocks reverse flow of current during battery mode. Capacitors C2 and C3 acts as filters.

All gratitude to our thesis supervisor, Prof. Dr. M. Shamsul Alam Professor and Dean Faculty of Science And Information Technology Daffodil International University for his valuable suggestions and guidance throughout this project work. He always help to our working day in electronic lab and find our project fault, finally he advice how made the project.

REFERENCES

- [1] <https://en.wikipedia.org/wiki/Diode>
- [2] <http://www.rakeshmondal.info/Articles-and-Poems>
- [3] <http://en.wikipedia.org/wiki/Transformer>
- [4] <http://en.wikipedia.org/wiki/Rectifier>
- [5] <http://www.scribd.com>
- [6] http://en.wikipedia.org/wiki/Diode_bridge
- [7] <http://electronics.stackexchange.com>
- [8] http://www.electronics-tutorials.ws/diode/diode_6.html
- [9] <http://en.wikipedia.org/wiki/Capacitor>
- [10] www.circuitstoday.com