

# **Development, recent trends & future prospects of electronics**

A thesis submitted in partial fulfillment of the requirement for the degree

of

Bachelor of Science in Electrical and Electronic Engineering

**Supervised by**

**Dr. M. Samsul Alam**

Professor & Head

Dept. of EEE

Daffodil International University

**Submitted by**

**Habiba Zaman**

ID : 093-33-101



**Department of Electrical and Electronic Engineering**

**Daffodil International University**

**October 2013**

**DEDICATED**

To my beloved parents

# ACKNOWLEDGEMENT

At first I am greatly praise to almighty Allah for successful completion of my undergraduate thesis.

I want to thanks my thesis Supervisor Professor Dr. Md. Samsul Alam for his encouragement and for giving me permission to involve with electronics related thesis. I have done my thesis according to his direction.

I am also grateful to my respected teachers, specially, Md. Dara Abdus Sattar in his role as Lecturer, for his assistance, guidance and enthusiasm throughout this thesis.

I thank all staffs of my departments for their help during working period.

I am extremely grateful to my parents, family member and friends for their support, constant love and sacrifice.

Finally, I beg pardon for my unintentional errors and omission if any.

# CONTENTS

	<b>Page</b>
<b>ABSTRACT</b>	10
<b>CHAPTER 1- INTRODUCTION</b>	11
<b>1.1 Preface</b>	11
<b>1.1 Electronic components &amp; devices</b>	12
<b>1.2.1 Active components</b>	12
1.2.1.1 Diodes	13
1.2.1.2 Transistors	14
• BJT	15
• Structure of BJT	15
• NPN	16
• PNP	16
• MOSFET	17
• MOSFET structure	17
• CMOS circuits	18
1.2.1.3 Integrated circuits	18
1.2.1.4 Vacuum tubes	19
<b>1.2.2 Passive components</b>	20
1.2.2.1 Resistors	20
1.2.2.2 Capacitors	21
<b>1.3 Operational amplifier</b>	21
<b>1.4 Difference between active &amp; passive components</b>	22

<b>CHAPTER 2- HISTORY OF ELECTRONICS</b>	23
<b>2.1 Diodes (History)</b>	23
2.1.1 Discovery of vacuum tube diodes	23
2.1.2 Solid state diodes	24
<b>2.2 Transistors (History)</b>	24
<b>2.3 Integrated circuits (History)</b>	25
<b>2.4 Vacuum tubes (History)</b>	26
<b>2.5 Capacitors (History)</b>	26
<b>2.6 Timeline of electronics inventions</b>	27
<b>2.7 Use of electronic appliances &amp; its facilities</b>	33
<b>CHAPTER 3- ELECTRONICS MEASURING INSTRUMENTS</b>	38
<b>3.1 Electronics/ Measuring instruments</b>	39
<b>3.1.1 Multimeters</b>	39
3.1.3.1 Digital multimeters	40
3.1.3.2 Analog multimeters	40
<b>3.1.2 Ammeters</b>	40
3.1.2.1 Moving-coil ammeters	41
3.1.2.2 Electrodynamics ammeters	41
3.1.2.3 Moving-iron ammeters	41
3.1.2.4 Hot wire ammeters	42

3.1.2.5 Digital ammeters	42
3.1.2.6 Integrating ammeters	42
<b>3.1.3 Frequency Counter</b>	42
<b>3.1.4 Pulse Generator</b>	43
<b>3.2 Electronics Laboratory Instruments</b>	44
<b>3.2.1 Oscilloscope</b>	44
3.2.1.1 Types	45
• Cathode-ray oscilloscope	45
• Duel beam oscilloscope	46
• Analog storage oscilloscope	46
• Digital oscilloscope	47
• Mixed signal oscilloscope	47
• Handheld oscilloscope	47
• PC- based oscilloscope	48
<b>3.2.2 Spectrum analyzers</b>	48
<b>3.2.3 Logic probe</b>	50
<b>3.2.4 Digital Pattern Generator</b>	51
<b>3.2.5 LCR Meter</b>	52
<b>3.2.6 Frequency Synthesizer</b>	53
<b>CHAPTER 4- Application of electronics measuring instruments</b>	55

<b>CHAPTER 5- Electronics related Inventors &amp; their inventions</b>	<b>57</b>
• John Logie Baird	57
• Alexander Graham Bell	57
• Thomas Alva Edison	57
• Guglielmo Marconi	58
• Samuel Finley Breese Morse	58
• Edwin Herbert Land	58
• Nikola Tesla	59
• Chester Floyd Carlson	59
<b>CHAPTER 6- The Best Future inventions</b>	<b>60</b>
6.1 Quantum computers	60
6.2 Laptop antiques	60
6.3 Flying cars	60
6.4 Needle-less injection	60
6.5 Graphine	61
6.6 Zero-size intelligence	61
6.7 Holographic displays	61
6.8 Time Travel	61
6.9 Nanotech Computing	62
6.10 The Sonic Screwdrive	62
6.11 The Tricorder	62

6.12 Robot Soldiers	62
6.13 The Land speeder	62
6.14 Flexible Displays	62
<b>Chapter 7- Conclusion</b>	<b>63</b>

### **List of figure**

Figure 1.1	11
Figure 1.2	12
Figure 1.3	13
Figure 1.4	15
Figure 1.5	16
Figure 1.6	16
Figure 1.7	17
Figure 1.8	18
Figure 1.9	19
Figure 1.10	20
Figure 1.11	20
Figure 1.12	21
Figure 1.13	22



Figure 2.1	25
Figure 2.2	26
Figure 2.3	27
Figure 3.1	39
Figure 3.2	43
Figure 3.3	44
Figure 3.4	45
Figure 3.5	45
Figure 3.6	46
Figure 3.7	47
Figure 3.8	47
Figure 3.9	48
Figure 3.10	49
Figure 3.11	51
Figure 3.12	52
Figure 3.13	53
Figure 3.14	54
<b>References</b>	64
<b>Appendix</b>	69

# **ABSTRACT**

Electronics are anything that runs on electricity or batteries such as TVs', stereos, computers, DVD players, e.t.c. It is the branch of physics that deals with the emission and effects of electrons and the operation of electronic devices. Electronics deals with electrical circuits that involve active electrical components such as vacuum tubes, transistors, diodes and integrated circuits, and associated passive interconnection technologies. The nonlinear behavior of active components and their ability to control electron flows makes amplification of weak signals possible and electronics is widely used in information processing, telecommunications, and signal processing. The ability of electronic devices to act as switches makes digital information processing possible. Interconnection technologies such as circuit boards, electronics packaging technology, and other varied forms of communication infrastructure complete circuit functionality and transform the mixed components into a regular working system.

# Chapter 1

## Introduction

### 1.1 Preface

Electronics deals in lower level of current and voltages & uses semiconductor. It utilizes electricity. Electrons, a component of atoms, and their use---known as electronics---play an important role in many pieces of household equipment. Basic electronics comprises the minimal "electronics components" that make up a part of everyday electronics equipment. These electronic components include resistors, transistors, capacitors, diodes, inductors and transformers. Powered by a battery, they are designed to work under certain physics laws and principles.

Today in the twenty first century, many consumers, military, and recreational products are made with electronic devices. Perhaps, in the future we will see even more uses of Electronics. Almost all phases of modern technological society use Electronics, even this computer that is being used to type this script. The home, car, or the workplace all use Electronics. We all use Electronics but very few know the complex history behind Electronics. (Ref: IEEE Dictionary of Electrical and Electronics Terms ISBN 978-0-471-42806-0)



**Fig 1.1: Electronic appliances**



include amplifying components such as transistors, triode vacuum tubes (valves), and tunnel diodes.

### **1.2.1.1 Diodes**

In electronics, a diode is a two-terminal electronic component with asymmetric conductance, it has low (ideally zero) resistance to current flow in one direction, and high (ideally infinite) resistance in the other. Diodes were the first semiconductor electronic devices. The first semiconductor diodes, called cat's whisker diodes, developed around 1906, were made of mineral crystals such as galena. Today most diodes are made of silicon, but other semiconductors such as selenium or germanium are sometimes used. (Ref: Lowe, Doug (2013). "Electronics Components: Diodes". Electronics All-In-One Desk Reference For Dummies. John Wiley & Sons. Retrieved January 4, 2013.)



**Fig -1.3: Diode**

### **Thermionic diodes**

A thermionic diode is a thermionic-valve device (also known as a vacuum tube, tube, or valve), consisting of a sealed evacuated glass envelope containing two electrodes: a cathode heated by a filament, and a plate (anode). Early examples were fairly similar in appearance to incandescent light bulbs.

In operation, a separate current through the filament (heater), a high resistance wire made of nichrome, heats the cathode red hot (800-1000° C), causing it to release electrons into the vacuum, a process called thermionic emission. The cathode is coated with oxides of alkaline earth metals such as barium and strontium oxides, which have a low work

function, to increase the number of electrons emitted. (Some valves use *direct heating*, in which a tungsten filament acts as both heater and cathode.) The alternating voltage to be rectified is applied between the cathode and the concentric plate electrode. When the plate has a positive voltage with respect to the cathode, it electrostatically attracts the electrons from the cathode, so a current of electrons flows through the tube from cathode to plate. However when the polarity is reversed and the plate has a negative voltage, no current flows, because the cathode electrons are not attracted to it. The unheated plate does not emit any electrons itself. So current can only flow through the tube in one direction, from cathode to plate.

## **Semiconductor diode**

### **Electronic symbols:**



It is made of semiconductor components, usually silicon. The cathode, which is negatively charged and has an excess of electrons, is placed adjacent to the anode, which has an inherently positive charge, carrying an excess of holes. At this junction a depletion region forms, with neither holes nor electrons. A positive voltage at the anode makes the depletion region small, and current flows; a negative voltage at the anode makes the depletion region large, preventing current flow.

### **1.2.1.2 Transistors**

A transistor is a semiconductor device used to amplify and switch electronic signals and electrical power. It is composed of semiconductor material with at least three terminals for connection to an external circuit. A voltage or current applied to one pair of the transistor's terminals changes the current through another pair of terminals. Because the controlled (output) power can be higher than the controlling (input) power, a transistor can amplify a signal.

The transistor is the fundamental building block of modern electronic devices, and is ubiquitous in modern electronic systems. Following its development in the early 1950s, the transistor revolutionized the field of electronics, and paved the way for smaller and cheaper radios, calculators, and computers, among other things. (Ref: Streetman, Ben (1992). Solid State Electronic Devices. Englewood Cliffs, NJ: Prentice-Hall. pp. 301–305. ISBN 0-13-822023-9.

## Bipolar junction transistor

A bipolar junction transistor (BJT or bipolar transistor) is a type of transistor that relies on the contact of two types of semiconductor for its operation. BJTs can be used as amplifiers, switches, or in oscillators. BJTs come in two types, or polarities, known as PNP and NPN based on the doping types of the three main terminal regions. An NPN transistor comprises two semiconductor junctions that share a thin p-doped anode region, and a PNP transistor comprises two semiconductor junctions that share a thin n-doped cathode region.

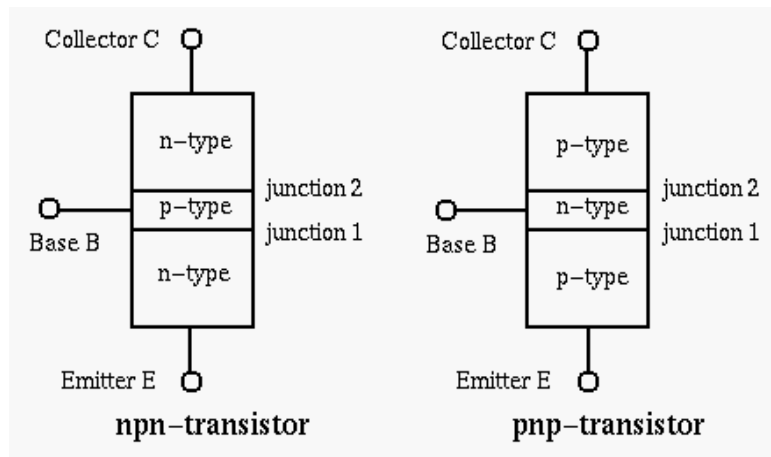

Fig-1.4: NPN & PNP BJT

## Structure of BJT

A BJT consists of three differently doped semiconductor regions, the emitter region, the base region and the collector region. These regions are, respectively, p type, n type and p type in a PNP transistor, and n type, p type and n type in an NPN transistor. Each

semiconductor region is connected to a terminal, appropriately labeled: emitter (E), base (B) and collector (C). (Ref: Juin Jei Liou and Jiann S. Yuan (1998). Semiconductor Device Physics and Simulation. Springer. ISBN 0-306-45724-5.)

## NPN

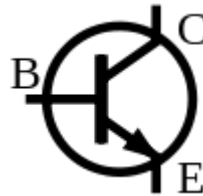

**Fig-1.5: The symbol of an NPN BJT.**

NPN is one of the two types of bipolar transistors, consisting of a layer of P-doped semiconductor (the "base") between two N-doped layers. A small current entering the base is amplified to produce a large collector and emitter current. That is, when there is a positive potential difference measured from the emitter of an NPN transistor to its base (i.e., when the base is high relative to the emitter) as well as positive potential difference measured from the base to the collector, the transistor becomes active. In this "on" state, current flows between the collector and emitter of the transistor.

## PNP



**Fig-1.6: The symbol of a PNP BJT.**

The other type of BJT is the PNP, consisting of a layer of N-doped semiconductor between two layers of P-doped material. A small current leaving the base is amplified in the collector output. That is, a PNP transistor is "on" when its base is pulled low relative to the emitter.



## MOSFET

The metal–oxide–semiconductor field-effect transistor (MOSFET, MOS-FET, or MOS FET) is a transistor used for amplifying or switching electronic signals. Although the MOSFET is a four-terminal device with source (S), gate (G), drain (D), and body (B) terminals, the body (or substrate) of the MOSFET often is connected to the source terminal, making it a three-terminal device like other field-effect transistors. Because these two terminals are normally connected to each other (short-circuited) internally, only three terminals appear in electrical diagrams. The MOSFET is by far the most common transistor in both digital and analog circuits, though the bipolar junction transistor was at one time much more common.

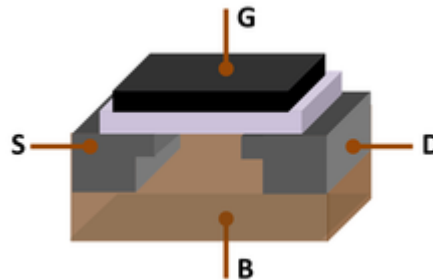

**Fig-1.7: MOSFET showing gate (G), body (B), source (S) and drain (D) terminals. The gate is separated from the body by an insulating layer (white).**

### MOSFET structure

A metal–oxide–semiconductor field-effect transistor (MOSFET) is based on the modulation of charge concentration by a MOS capacitance between a body electrode and a gate electrode located above the body and insulated from all other device regions by a gate dielectric layer which in the case of a MOSFET is an oxide, such as silicon dioxide. If dielectrics other than an oxide such as silicon dioxide (often referred to as oxide) are employed the device may be referred to as a metal–insulator–semiconductor FET (MISFET). Compared to the MOS capacitor, the MOSFET includes two additional terminals (source and drain), each connected to individual highly doped regions that are separated by the body region. These regions can be either p or n type, but they must both be of the same type, and of opposite type to the body region. The source and drain (unlike

the body) are highly doped as signified by a '+' sign after the type of doping. (Ref: U.A.Bakshi, A.P.Godse (2007). "§8.2 The depletion mode MOSFET". *Electronic Circuits*. Technical Publications. pp. 8–2. ISBN 978-81-8431-284-3.)

## **CMOS circuits**

The MOSFET is used in digital complementary metal–oxide–semiconductor (CMOS) logic, which uses p- and n-channel MOSFETs as building blocks. Overheating is a major concern in integrated circuits since ever more transistors are packed into ever smaller chips. CMOS logic reduces power consumption because no current flows (ideally), and thus no power is consumed, except when the inputs to logic gates are being switched. CMOS accomplishes this current reduction by complementing every nMOSFET with a pMOSFET and connecting both gates and both drains together. A high voltage on the gates will cause the nMOSFET to conduct and the pMOSFET not to conduct and a low voltage on the gates causes the reverse. (Ref: P. R. van der Meer, A. van Staveren, A. H. M. van Roermund (2004). *Low-Power Deep Sub-Micron CMOS Logic: Subthreshold Current Reduction*. Dordrecht: Springer. p. 78. ISBN 1-4020-2848-2.)

### **1.2.1.3 Integrated circuits**

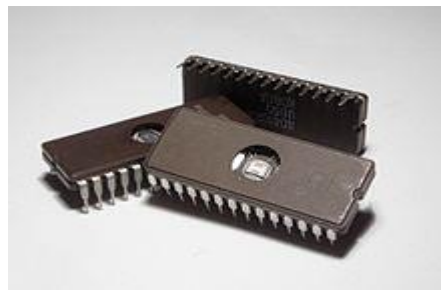

**Fig 1.8: Wide angle shot of the memory microchip**

An integrated circuit or monolithic integrated circuit (also referred to as an IC, a chip, or a microchip) is a set of electronic circuits on one small plate ("chip") of semiconductor material, normally silicon. This can be made much smaller than a discrete circuit made from independent components.

Integrated circuits are used in virtually all electronic equipment today and have revolutionized the world of electronics. Computers, mobile phones, and other digital home appliances are now inextricable parts of the structure of modern societies, made possible by the low cost of producing integrated circuits. (Ref: Andrew Wylie (2009). "The first monolithic integrated circuits". Retrieved 14 March 2011.)

#### **1.2.1.4 Vacuum tubes**



**Fig 1.9: Vacuum tubes**

A vacuum tube, electron tube (in North America), tube, or thermionic valve or valve (in British English) is a device controlling electric current through a vacuum in a sealed container. Vacuum tubes are thus used for rectification, amplification, switching, or similar processing or creation of electrical signals. Vacuum tubes are still used in some specialist applications such as high power RF amplifiers, cathode ray tubes, specialist audio equipment and some microwave devices. (Ref: Hoddeson, L. "The Vacuum Tube". PBS. Retrieved 6 May 2012.)

#### **1.2.2 Passive components**

Passive components include two-terminal components such as resistors, capacitors, inductors, and transformers.

### 1.2.2.1 Resistors

Resistors are the most commonly used component in electronics and their purpose is to create specified values of current and voltage in a circuit.



**Fig -1.10: Resistor**

The symbol for a resistor is shown in the following diagram (upper: American symbol, lower: European symbol.)

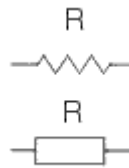

**Fig-1.11: Resistor symbols**

The unit for measuring resistance is the OHM. (the Greek letter  $\Omega$  - called Omega). Higher resistance values are represented by "k" (kilo-ohms) and M (meg ohms).

The current through a resistor is in direct proportion to the voltage across the resistor's terminals. This relationship is represented by Ohm's law:

$$I = \frac{V}{R}$$

where  $I$  is the current through the conductor in units of amperes,  $V$  is the potential difference measured across the conductor in units of volts, and  $R$  is the resistance of the

conductor in units of ohms. (Ref: Milwaukee Resistor Corporation. "Grid Resistors: High Power/High Current". Milwaukeeresistor.com. Retrieved on 2012-05-14.)

### 1.2.2.2 Capacitors

Capacitors are widely used in electronic circuits for blocking direct current while allowing alternating current to pass. In analog filter networks, they smooth the output of power supplies. In resonant circuits they tune radios to particular frequencies. In electric power transmission systems they stabilize voltage and power flow.



**Fig-1.12: A typical electrolytic capacitor**

A capacitor consists of two conductors separated by a non-conductive region. The non-conductive region is called the dielectric. In simpler terms, the dielectric is just an electrical insulator. (Ref: Dorf, Richard C.; Svoboda, James A. (2001). Introduction to Electric Circuits (5th ed.). New York: John Wiley & Sons. ISBN 9780471386896.)

## 1.3 Operational amplifier

An operational amplifier (op-amp) is a DC-coupled high-gain electronic voltage amplifier with a differential input and, usually, a single-ended output. In this configuration, an op-amp produces an output potential (relative to circuit ground) that is typically hundreds of thousands of times larger than the potential difference between its input terminals.



**Fig-1.13: A Signetics  $\mu$ A741 operational amplifier, one of the most successful op-amps.**

Operational amplifiers had their origins in analog computers, where they were used to do mathematical operations in many linear, non-linear and frequency-dependent circuits. Characteristics of a circuit using an op-amp are set by external components with little dependence on temperature changes or manufacturing variations in the op-amp itself, which makes op-amps popular building blocks for circuit design. (Ref: D.F. Stout Handbook of Operational Amplifier Circuit Design (McGraw-Hill, 1976, ISBN 0-07-061797-X ) pp. 1–11.)

#### **1.4 Difference between active & passive components**

1. Active devices inject power to the circuit, whereas passive devices are incapable of supplying any energy.
2. Active devices are capable of providing power gain, and passive devices are incapable of providing power gain.
3. Active devices can control the current (energy) flow within the circuit, whereas passive devices cannot control it.

# Chapter 2

## The history of electronics

### 2.1 Diodes

Thermionic (vacuum tube) diodes and solid state (semiconductor) diodes were developed separately, at approximately the same time, in the early 1900s, as radio receiver detectors.

#### 2.1.1 Discovery of vacuum tube diodes

In 1873, Frederick Guthrie discovered the basic principle of operation of thermionic diodes. Guthrie discovered that a positively charged electroscope could be discharged by bringing a grounded piece of white-hot metal close to it (but not actually touching it). The same did not apply to a negatively charged electroscope, indicating that the current flow was only possible in one direction.

Thomas Edison independently rediscovered the principle on February 13, 1880. At the time, Edison was investigating why the filaments of his carbon-filament light bulbs nearly always burned out at the positive-connected end. He had a special bulb made with a metal plate sealed into the glass envelope. Using this device, he confirmed that an invisible current flowed from the glowing filament through the vacuum to the metal plate, but only when the plate was connected to the positive supply.

Edison devised a circuit where his modified light bulb effectively replaced the resistor in a DC voltmeter. Edison was awarded a patent for this invention in 1884.<sup>[8]</sup> Since there was no apparent practical use for such a device at the time, the patent application was most likely simply a precaution in case someone else did find a use for the so-called Edison effect.

About 20 years later, John Ambrose Fleming (scientific adviser to the Marconi Company and former Edison employee) realized that the Edison effect could be used as a precision radio detector. Fleming patented the first true thermionic diode, the Fleming valve, in Britain on November 16, 1904.

### **2.1.2 Solid-state diodes**

In 1874 German scientist Karl Ferdinand Braun discovered the "unilateral conduction" of crystals. Braun patented the crystal rectifier in 1899. Copper oxide and selenium rectifiers were developed for power applications in the 1930s.

Indian scientist Jagadish Chandra Bose was the first to use a crystal for detecting radio waves in 1894. The crystal detector was developed into a practical device for wireless telegraphy by Greenleaf Whittier Pickard, who invented a silicon crystal detector in 1903 and received a patent for it on November 20, 1906. Other experimenters tried a variety of other substances, of which the most widely used was the mineral galena (lead sulfide). Other substances offered slightly better performance, but galena was most widely used because it had the advantage of being cheap and easy to obtain. The crystal detector in these early crystal radio sets consisted of an adjustable wire point-contact (the so-called "cat's whisker"), which could be manually moved over the face of the crystal in order to obtain optimum signal. This troublesome device was superseded by thermionic diodes by the 1920s, but after high purity semiconductor materials became available, the crystal detector returned to dominant use with the advent of inexpensive fixed-germanium diodes in the 1950s. Bell Labs also developed a germanium diode for microwave reception, and AT&T used these in their microwave towers that criss-crossed the nation starting in the late 1940s, carrying telephone and network television signals. Bell Labs did not develop a satisfactory thermionic diode for microwave reception. (Ref: Tooley, Mike (2012). *Electronic Circuits: Fundamentals and Applications*, 3rd Ed.. Routledge. p. 81. ISBN 1-136-40731-6.)

## **2.2 Transistors**

The thermionic triode, a vacuum tube invented in 1907, propelled the electronics age forward, enabling amplified radio technology and long-distance telephony. The triode, however, was a fragile device that consumed a lot of power. Physicist Julius Edgar Lilienfeld filed a patent for a field-effect transistor (FET) in Canada in 1925, which was intended to be a solid-state replacement for the triode. Lilienfeld also filed identical patents in the United States in 1926 and 1928.





**Fig 2.1: A replica of the first working transistor.**

The term transistor was coined by John R. Pierce as a portmanteau of the term "transfer resistor". In 1948, the point-contact transistor was independently invented by German physicists Herbert Mataré and Heinrich Welker while working at the Compagnie des Freins et Signaux, a Westinghouse subsidiary located in Paris. The first high-frequency transistor was the surface-barrier germanium transistor developed by Phil co in 1953, capable of operating up to 60 MHz.

Another important type of transistor developed by the early 1960s is the field-effect transistor, such as a metal-oxide-semiconductor field-effect transistor, or MOSFET.(Ref: Vardalas, John, Twists and Turns in the Development of the Transistor IEEE-USA Today's Engineer, May 2003.)

### **2.3 Integrated circuits**

Invention of the integrated circuit (IC) independently by Jack Kilby of Texas Instruments Incorporated in 1958 and by Jean Hoerni and Robert Noyce of Fairchild Semiconductor Corporation in 1959. Kilby is usually credited with having developed the concept of integrating device and circuit elements onto a single silicon chip, while Noyce is given credit for having conceived the method for integrating the separate elements.

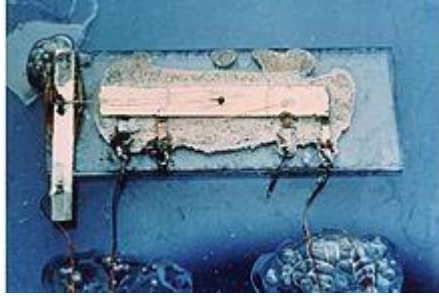

**Fig 2.2: Jack Kilby's original integrated circuit**

Early ICs contained about 10 individual components on a silicon chip 3 mm (0.12 inch) square. By 1970 the number was up to 1,000 on a chip of the same size at no increase in cost. Late in the following year the first microprocessor was introduced. The device contained all the arithmetic, logic, and control circuitry required to perform the functions of a computer's central processing unit (CPU). This type of large-scale IC was developed by a team at Intel Corporation, the same company that also introduced the memory IC in 1971. (Ref: Andrew Wylie (2009). "The first monolithic integrated circuits". Retrieved 14 March 2011.)

## **2.4 Vacuum tubes**

In 1906 Lee De Forest, an American engineer developed a type of vacuum tube that was capable of amplifying radio signals. The vacuum tube permitted the development of radio broadcasting, long-distance telephony, television, and the first electronic digital computers. (Ref: Sōgo Okamura (1994). History of electron tubes. IOS Press. pp. 133–. ISBN 978-90-5199-145-1. Retrieved 9 May 2011.)

## **2.5 Capacitors**

In October 1745, the Dutch physicist Pieter van Musschenbroek invented a similar capacitor, which was named the Leyden jar.

Daniel Galath was the first to combine several jars in parallel into a "battery" to increase the charge storage capacity. Benjamin Franklin investigated the Leyden jar and came to the conclusion that the charge was stored on the glass, not in the water as others had assumed. He also adopted the term "battery", (denoting the increasing of power with a

row of similar units as in a battery of cannon), subsequently applied to clusters of electrochemical cells.



**Fig-2.3: Solid-body, resin-dipped 10  $\mu$ F 35 V tantalum capacitors.**

Early capacitors were also known as *condensers*, a term that is still occasionally used today. The term was first used for this purpose by Alessandro Volta in 1782. (Ref: Dorf, Richard C.; Svoboda, James A. (2001). Introduction to Electric Circuits (5th ed.). New York: John Wiley & Sons. ISBN 9780471386896.)

## **2.6 Timeline of electronics inventions**

- 1510-** Leonardo DaVinci designs a horizontal water wheel.
- 1565-** A graphite pencil invented by Conrad Gesner.
- 1590-** Dutchmen, Zacharias Janssen invented the compound microscope.
- 1608-** Hans Lippershey invented the first refracting telescope.
- 1636-** W. Gascoigne invented the micrometer.
- 1650-** Otto von Guericke invented a air pump.
- 1663-** James Gregory invented the first reflecting telescope.
- 1675-** Christian Huygens patented the pocket watch.
- 1669-** Denis Papin invented the pressure cooker.
- 1698-** Englishmen, Thomas Savery invented a steam pump.

- 1701-** Jethro Tull invented the seed drill.
- 1709-** Bartolomeo Cristofori invented the piano.
- 1717-** Edmond Halley invented the diving bell.
- 1733-** John Kay invented the flying shuttle.
- 1758-** Dolland invented a chromatic lens.
- 1768-** Richard Arkwright patented the spinning frame.
- 1783-** Benjamin Hanks patented the self-winding clock.
- 1784-** Joseph Bramah invented the safety lock.
- 1786-** John Fitch invented a steamboat.
- 1792-** William Murdoch invented gas lighting.
- 1798-** Aloys Senefelder invented lithography.
- 1799-** Alessandro Volta invented the battery.
- 1809-** Humphry Davy invented the first electric light - the first arc lamp.
- 1815-** Humphry Davy invented the miner's lamp.
- 1819-** René Laennec invented the stethoscope.
- 1827-** 1<sup>st</sup> camera invented.
- 1829-** American, W.A. Burt invented a typewriter.
- 1832-** The first patented stereoscope was invented by Wheatstone and patented in 1838.
- 1835-** Englishmen, Henry Talbot invented calotype photography & Charles Babbage invented a mechanical calculator.
- 1836-** Samuel Colt invented the first revolver.

- 1837-** Samuel Morse invented the telegraph.
- 1839-** Kirkpatrick Macmillan invented a bicycle.
- 1840-** Englishmen, John Herschel invented the blueprint.
- 1841-** Samuel Slocum patented the stapler.
- 1845-** American, Elias Howe invented a sewing machine.
- 1852-** Jean Bernard Léon Foucault invented gyroscope.
- 1857-** George Pullman invented the Pullman Sleeping Car for train travel.
- 1858-** Hamilton Smith patented the rotary washing machine.
- 1861-** Linus Yale invented the Yale lock or cylinder lock.
- 1867-** Christopher Scholes invented the first practical and modern typewriter.
- 1877-** Thomas Edison invented the tin foil phonograph.
- 1880-** Englishmen, John Milne invented the modern seismograph.
- 1881-** Alexander Graham Bell invented the first crude metal detector.
- 1885-** Harim Maxim invented the machine gun & Gottlieb Daimler invented the first gas-engined motorcycle.
- 1886-** Gottlieb Daimler builded the world's first four-wheeled motor vehicle.
- 1887-** Emile Berliner invented the gramophone & F.E. Muller and Adolph Fick invented the first wearable contact lenses.
- 1891-** Jesse W. Reno invented the escalator.
- 1895-** Lumiere Brothers invented a portable motion-picture camera.
- 1899-** John Thurman patented the motor-driven vacuum cleaner.
- 1900-** Charles Seeberger redesigned Jesse Reno's escalator and invented the modern escalator.

- 1901-** Hubert Booth invented a compact and modern vacuum cleaner.
- 1902-** Willis Carrier invented the air conditioner & George Claude invented neon light.
- 1903-** Mary Anderson invented windshield wipers. & William Coolidge invents ductile tungsten used in light bulbs.
- 1904-** Sir John Ambrose Fleming, a professor, invented the thermionic valve, or diode, a two-electrode rectifier.
- 1906-** Lewis Nixon invented the first sonar like device.
- 1907-** Lee De Forest, an American inventor, files for a patent on a triode.
- 1912-** Motorized movie cameras invented, replaced hand-cranked cameras.
- 1914-** Garrett A. Morgan invented the Morgan gas mask.
- 1916-** Radio tuners invented, that received different stations & stainless steel invented by Henry Brearly.
- 1918-** The super heterodyne radio circuit invented by Edwin Howard Armstrong. Today, every radio or television set uses this invention.
- 1919-** The pop-up toaster invented by Charles Strite.
- 1921-** Artificial life begins -- the first robot built & John Larson invented the lie detector.
- 1923-** The television or iconoscope (cathode-ray tube) invented by Vladimir Kosma Zworykin & John Harwood invented the self-winding watch.
- 1924-** The dynamic loudspeaker invented by Rice and Kellogg & notebooks with spiral bindings invented.
- 1927-** JWA Morrison invented the first quartz crystal watch, Philo Taylor Farnsworth invented a complete electronic TV system
- 1929-** American, Paul Galvin invented the car radio.
- 1931-** Germans Max Knott and Ernst Ruska co-invented the electron microscope.

- 1932-** The zoom lens and the light meter invented, Carl C. Magee invents the first parking meter & Karl Jan sky invents the radio telescope.
- 1937-** Chester F. Carlson invented the photocopier.
- 1938-** Strobe lighting invented.
- 1940** Peter Goldmark invented modern color television system.
- 1946-** The microwave oven invented by Percy Spencer.
- 1947-** Brattain and Bardeen build the first pointcontact transistor, made of two gold foil contacts sitting on a germanium crystal.
- 1951-** Charles Ginsburg invented the first video tape recorder (VTR).
- 1952-** 1<sup>st</sup> commercial device to apply schochley junction transistor.
- 1953-** Radial tires invented.
- 1955-** Carl Frosch and Link Derick at Bell Labs discover that silicon dioxide can act as a diffusion mask & Optic fiber invented.
- 1958-** The computer modem invented.
- 1959-** The internal pacemaker invented by Wilson Greatbatch & Jack Kilby and Robert Noyce both invent the microchip.
- 1962-** MOSFET is invented by engineers Steven Hofstein & the audio cassette invented & the fiber-tip pen invented by Yukio Horie.
- 1963-** The video disk invented.
- 1965-** Automatic adaptive equalizer invented by Robert Lucky.
- 1966-** Dr. Robert W. Bower invented the self-aligned gate process for fabricating field effect transistors & electronic Fuel injection for cars invented.
- 1967-** First handheld calculator invented.
- 1968-** The computer mouse invented by Douglas Engelbart.

- 1969-** The bar-code scanner is invented.
- 1970-** The floppy disk invented by Alan Shugart.
- 1971-** The dot-matrix printer invented & the microprocessor invented by Faggin, Hoff and Mazor & VCR or videocassette invented.
- 1973-** Bic invented the disposable lighter.
- 1975-** The laser printer invented.
- 1979-** Cell phones invented, Cray supercomputer invented by Seymour Cray & Walkman invented.
- 1983-** The Apple Lisa invented & Soft bifocal contact lens invented.
- 1986-** Fuji introduced the disposable camera.
- 1987-** Disposable contact lenses invented.
- 1988-** Digital cellular phones invented.
- 1989-** High-definition television invented.
- 1991-** The digital answering machine invented.
- 1996-** Web TV invented.
- 2002 -** Canasta and VKB invent the virtual keyboard.
- 2003 -** Toyota's Hybrid Car is introduced in Japan.
- 2004 -** Intel Express Chipsets are invented by Gransdale and Alderwood
- 2007 -** Jonathan Ive of England invented the iPhone for Apple.
- 2011-** Swedish Engineer, Alex Breton invented the Print Brush, a combination camera, in jet printer that can take a picture and then 'brush' the picture onto any medium.



## **Why we do use electronic appliances & its facilities**

### **Refrigerators**

We use a fridge to store food and drinks and also to slow down the process of bacteria breeding and spreading around the food in our fridge. Main advantages of this appliance is that we will not have to rush to the market regularly, we can store things for a longer time in our refrigerator, all the leftover items can hence be preserved and used for future use and most importantly it gives a protection against the pests. All the items kept in this appliance gives a better taste and hence, can then believe in the concept of eating healthy and hence living a comfortable life. Long time ago, when the value of money was very high, people could not buy refrigerator easily because of high expanse of refrigerator. In spite of having same expanse of refrigerator, people can afford it now a days. This is because of the value of decrease of money.

### **Televisions**

Now a day, we can watch any kind of near & distant news regarding communication. As, for example: worldwide news like revolution of communication. Television is used to stay current on news, for entertainment, play games, watch videos etc. TV was entertaining at first. It brought us local news & broadcasts included not only news and music, but dramas, comedies, variety shows, and many other forms of entertainment.

### **Air conditioner**

We use air conditioning to "condition the air" in our homes to make the dwellings more comfortable. There are a number of geo-climatic areas where the weather brings in long stretch of hot days (and nights). Temperatures in excess of 90 °F (or even 100 °F) are possible for many days in a row, and air conditioning provides a way to take the edge off this heat inside our homes. Because of it, we can use refrigeration technology to maintain our homes at something a shade under 80 °F so we can be more comfortable.

### **Washing machine**

The washing machine is an ideal house hold equipment, it washes our cloths clean, uses less of detergent and less of water. It save our valuable time & reduce our affort to clean cloths manually.

### **Mobile phones**

Mobile phones have changed lives of humans and the reasons behind the same are quite simple. Back in 80s and 90s, people used to have mobiles only for basic purpose such as calling another person. Even Short Messaging Service (SMS) on which we are more reliable was not at all popular during those days. Such five important reasons to why we use mobile phones.

- 1) Internet
- 2) Texting
- 3) Listening to music
- 4) Applications
- 5) Games

Because of it we are able to keeping in touch with family members, conducting business, and having access to a telephone in the event of an emergency. Some people carry more than one cell phone for different purposes, such as for business and personal use.

### **Computers**

We use computers in order to simplify tough calculations as we compute figures. Computers are also enjoyable to use as they allow us to communicate and share ideas with people who are far away. Through all types of communication (via internet) we can advertise, sell, chat, phone calls, location to location & many other things. Robots and machines that mass produce anything runs off of a computer. We also use them for playing games and for playing music & also are an easy solution for drawing up plans/data instead of by hand.

### **Fax machines**

More than ever before, it is easy to communicate with people in a variety of different ways. A fax machine can send and receive documents that include text and images simply at the push of a button. The advantage of a fax machine over anemina is that it takes a physical document from the sender and transmits it in physical form to the receiver. A fax is also an ideal device for somebody who doesn't have a computer, as it allows them to send and receive messages almost instantly. It may cost little more I the long run, and it may take longer to transmit than an e-mail; but a fax is received as a printed document, so it does save us the time that would be spent opening an e-mail and printing it. Faxing is also great for documents that need to be signed, as we can add our signature and send them right back. Even though the world is run on computers today, we'll find that most offices still use fax machines as a quick and easy way to send our information both internally and externally.

### **Photocopiers**

A photocopy machine is a machine that makes copies of papers. To make a photocopy place the correct size paper in the paper tray. The advantage of using a photocopier machine is usually cheaper to use compared to using a printer. Plus, the machine copies your document fast, so we don't have to wait that long, it makes many copies at once, it is cheap to use, it copies our document fast and accurately and a disadvantage is that it can aid in fraudulent document creation & the machine itself is very expensive.

### **Security cameras**

Security cameras are about prevention. Not to mention their amazing deterrent power to stop the bad guys from even trying. It is also useful for public safety, to catch a criminal & evidence. With today's technology and advancements, computerized monitoring and security systems have become a necessity and part of our daily life. Until few years ago having such security systems was a luxury and was mainly used by large corporations and the well to do. However, these systems have dramatically dropped in price and have become such commodity items that today all sectors of community can enjoy their immense benefits.

### **Digital cameras**

Taking pictures with a digital camera is almost exactly the same as taking pictures with a film camera - but instead of needing chemical processing and printing, digital photos are files that can be loaded onto a computer, emailed to friends and uploaded to facebook. If we want prints, we can print them out at home or at a local shop, but most digital pictures live a purely digital life.

The best thing about taking photos with a digital camera is that if we didn't get everything right, we can crop and retouch your pictures using computer software (such as Adobe Photoshop) or do it online at a photo-editing site. It's all very liberating, until we start to run out of battery power.

### **Printers**

We use printers to print out projects and stuff instead of just writing it on a piece of paper. We need printers, 5 things to Print:

- 1) Boarding passes
- 2) Art
- 3) Invoices & Resumes
- 4) Shipping labels
- 5) Photos.

### **Mp3 & Mp4 players**

It is a personal electronic device most often used to store and play back music files.

By mp4 players we can play video in a multitude of video formats without the need to pre-convert them or downsize them prior to playing them. Some MP4 Players possess USB ports in order for the users to connect it to a PC. Some have memory cards to expand the memory of the player instead of storing files in the built-in memory.

### **Vacuum cleaners**

A vacuum cleaner is a device that uses an air pump to create a partial vacuum to suck up dust and dirt, usually from floors, and optionally from other surfaces as well. Because of it we clean our house & office very easily.

### **Microwave ovens**

The microwave is basically one of the standard appliances in almost every kitchen these days, because it is very easy and comfortable to use and also it makes sure that the food preserves the maximum nutrient value because of its shorter cooking time. Microwave ovens are popular for reheating previously cooked foods and cooking vegetables. They are also useful for rapid heating of otherwise slowly prepared cooking items, such as hot butter, fats, and chocolate & baking. We can cook almost anything in it in a fraction of the time it takes to cook it in a conventional oven. We can also cook delicious food, cake etc by microwave ovens. Now a days we become health conscious because of it, its also save our time.

### **Water purifiers & heaters**

We can no longer ignore the facts concerning the dangers of tap water, which even though may taste or smell good, contains contaminants, which unknowingly are threatening our health. A home water filtration system has become a practical necessity. For our health, the health of our family and that of the planet, a good in-home water filtration system is the only answer. The only way to ensure pure, contaminant-free drinking water is through the use of a point-of-use filtration system.

### **Induction cooker**

Induction is the first technology that offers all of the benefits of cooking with gas, with none of the drawbacks. Until now, gas is always outperformed electric cooking surface. Induction cooker is faster, safer & cheaper. It saves our gas & time.

# Chapter 3

## Electronics measuring instruments

A measuring instrument is a device for measuring a physical quantity. In the physical sciences, quality assurance, and engineering, measurement is the activity of obtaining and comparing physical quantities of real-world objects and events. Scientists, engineers and other humans use a vast range of instruments to perform their measurements. These instruments may range from simple objects such as rulers and stopwatches to electron microscopes and particle accelerators. Virtual instrumentation is widely used in the development of modern measuring instruments.

### 3.1 Electronics/ Measuring Instruments

- 3.1.1 Multimeters
- 3.1.2 Ammeters
- 3.1.3 Frequency counter
- 3.1.4 Pulse generator

### 3.2 Electronics Laboratory Instruments

- 3.2.1 Oscilloscope
- 3.2.2 Spectrum Analyzer
- 3.2.3 Logic probe
- 3.2.4 Digital pattern generator
- 3.2.5 LCR meters
- 3.2.6 Frequency synthesizers

## 3.1 Electronics/ Measuring Instruments

### 3.1.1 Multimeter

A multimeter or a multimeter, also known as a VOM (Volt-Ohm meter), is an electronic measuring instrument that combines several measurement functions in one unit. A typical multimeter would include basic features such as the ability to measure voltage, current, and resistance. Analog multimeters use a micrometer whose pointer moves over a scale calibrated for all the different measurements that can be made. Digital multimeters (DMM, DVOM) display the measured value in numerals, and may also display a bar of a length proportional to the quantity being measured.

Multimeters contain Ohmmeters, Voltmeters, Ammeters and a variety of capabilities to measure other quantities. AC and DC voltages are most often measurable. Frequency of AC voltages.

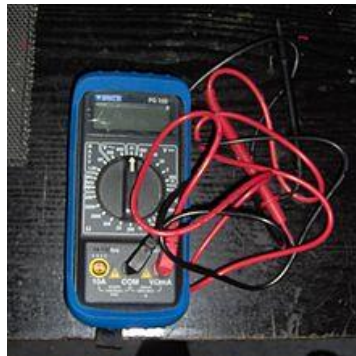

**Fig-3.1: A digital multimeter**

Multimeters also feature a continuity detector, basically an Ohmmeter with a beeper if the multimeter sees less than  $100\ \Omega$  then it beeps otherwise it is silent. This is very useful for finding whether components are connected when debugging or testing circuits. Multimeters are also often able to measure capacitance and inductance. This may be achieved using a Wien bridge. A diode tester is also generally on board, this allows one to determine the anode and cathode of an unknown diode. A LCD display is also provided for easily reading of results.

### **3.1.1.1 Digital multimeters (DMM or DVOM)**

Modern digital multimeters may have an embedded computer, which provides a wealth of convenience features. Measurement enhancements available include:

- Auto-ranging.
- Auto-polarity for direct-current readings.
- Sample and hold, Current-limited tests for voltage drop across semiconductor junctions.
- A graphic representation of the quantity under test, as a bar graph.
- Automotive circuit testers.
- Simple data acquisition features to record maximum and minimum readings over a given period.

The first digital multimeter was manufactured in 1955 by Non Linear Systems.

### **3.1.1.2 Analog multimeters**

Analog meters are able to display a changing reading in real time, whereas digital meters present such data in a manner that's either hard to follow or more often incomprehensible. Also an intelligible digital display follows changes in a circuit far more slowly than an analog movement, so often fails to show what's going on clearly. Some digital multimeters include a fast-responding bar graph display for this purpose, though the resolution of these is usually low. (Ref: Jones, David. "Multimeter Input Fuse Protection". EEVblog. Retrieved 28 December 2012.)

### **3.1.2 Ammeters**

An ammeter is a measuring instrument used to measure the electric current in a circuit. Electric currents are measured in amperes (A), hence the name. Instruments used to measure smaller currents, in the mill ampere or microampere range, are designated as



milliammeters or micro ammeters. Early ammeters were laboratory instruments which relied on the Earth's magnetic field for operation. By the late 19th century, improved instruments were designed which could be mounted in any position and allowed accurate measurements in electric power systems.

Basically an ammeter consists of a coil that can rotate inside a magnet, but a spring is trying to push the coil back to zero. The larger the current that flows through the coil, the larger the angle of rotation, the torque (= a rotary force) created by the current being counteracted by the return torque of the spring. Usually ammeters are connected in parallel with various switched resistors that can extend the range of currents that can be measured. Assume, for example, that the basic ammeter is "1000 ohms per volt", which means that to get the full-scale deflection of the pointer a current of 1 mA is needed (1 volt divided by 1000 ohms is 1 mA - see "Ohm's Law").

## **Types**

### **3.1.2.1 Moving-coil ammeters**

The D'Arsonval galvanometer is a moving coil ammeter. It uses magnetic deflection, where current passing through a coil causes the coil to move in a magnetic field.

### **3.1.2.2 Electrodynamics ammeters**

An electrodynamic movement uses an electromagnet instead of the permanent magnet of the d'Arsonval movement. This instrument can respond to both alternating and direct current and also indicates true RMS for AC.

### **3.1.2.3 Moving-iron ammeters**

Moving iron ammeters use a piece of iron which moves when acted upon by the electromagnetic force of a fixed coil of wire. This type of meter responds to both direct and alternating currents (as opposed to the moving-coil ammeter, which works on direct

current only). The iron element consists of a moving vane attached to a pointer, and a fixed vane, surrounded by a coil.

#### **3.1.2.4 Hot-wire ammeters**

In a hot-wire ammeter, a current passes through a wire which expands as it heats. Although these instruments have slow response time and low accuracy, they were sometimes used in measuring radio-frequency current. These also measure true RMS for an applied AC current.

#### **3.1.2.5 Digital ammeters**

Digital ammeter designs use a shunt resistor to produce a calibrated voltage proportional to the current flowing. This voltage is then measured by a digital voltmeter, through use of an analog to digital converter (ADC); the digital display is calibrated to display the current through the shunt.

#### **3.1.2.6 Integrating ammeters**

There is also a range of devices referred to as integrating ammeters. In these ammeters the current is summed over time, giving as a result the product of current and time; which is proportional to the energy transferred with that current. These can be used for energy meters (watt-hour meters) or for estimating the charge of battery or capacitor.(Ref: L. A. Geddes, Looking back: how measuring electric current has improved through the ages, IEEE Potentials, Feb/Mar 1996, pages 40-42)

### **3.1.3 Frequency Counter**

A frequency counter is an electronic instrument, or component of one, that is used for measuring frequency. Frequency is defined as the number of events of a particular sort occurring in a set period of time. Frequency counters usually measure the number of oscillations or pulses per second in a repetitive electronic signal.



**Fig- 3.2: Frequency counter**

Most frequency counters work by using a counter which accumulates the number of events occurring within a specific period of time. After a preset period known as the *gate time* (1 second, for example), the value in the counter is transferred to a display and the counter is reset to zero. If the event being measured repeats itself with sufficient stability and the frequency is considerably lower than that of the clock oscillator being used, the resolution of the measurement can be greatly improved by measuring the time required for an entire number of cycles, rather than counting the number of entire cycles observed for a pre-set duration. (Ref: Johansson, Staffan. "New frequency counting principle improves resolution". Spectracom. Retrieved 24 July 2013.)

### **3.1.4 Pulse Generator**

A pulse generator is either an electronic circuit *or* a piece of electronic test equipment used to generate rectangular pulses. Light pulse generators are the optical equivalent to electrical pulse generators with rep rate, delay, width and amplitude control. The output in this case is light typically from a LED or laser diode.



**Fig- 3.3: Pulse generators in a physics laboratory**

A new family of pulse generators can produce multiple-channels of independent widths and delays and independent outputs and polarities. Often called digital delay/pulse generators, the newest designs even offer differing repetition rates with each channel. These digital delay generators are useful in synchronizing, delaying, gating and triggering multiple devices usually with respect to one event. One is also able to multiplex the timing of several channels onto one channel in order to trigger or even gate the same device multiple times.

## **3.2 Electronics Laboratory Instruments**

### **3.2.1 Oscilloscope**

An oscilloscope, previously called an oscillograph, and informally known as a scope, CRO (for cathode-ray oscilloscope), or DSO (for the more modern digital storage oscilloscope), is a type of electronic test instrument that allows observation of constantly varying signal voltages, usually as a two-dimensional graph of one or more electrical potential differences using the vertical or  $y$ -axis, plotted as a function of time (horizontal or  $x$ -axis). Many oscilloscopes (storage oscilloscopes) can also capture non-repeating waveforms for a specified time and show a steady display of the captured segment.



**Fig-3.4: Oscilloscope**

Oscilloscopes are commonly used to observe the exact wave shape of an electrical signal. Oscilloscopes are usually calibrated so that voltage and time can be read as well as possible by the eye. This allows the measurement of peak-to-peak voltage of a waveform, the frequency of periodic signals, the time between pulses, the time taken for a signal to rise to full amplitude (rise time), and relative timing of several related signals.

### 3.2.1.1 Types of oscilloscope

#### Cathode-ray oscilloscope (CRO)

The earliest and simplest type of oscilloscope consisted of a tube, a vertical amplifier, a timebase, a horizontal amplifier and a power supply. These are now called "analog" scopes to distinguish them from the "digital" scopes that became common in the 1990s and 2000s.

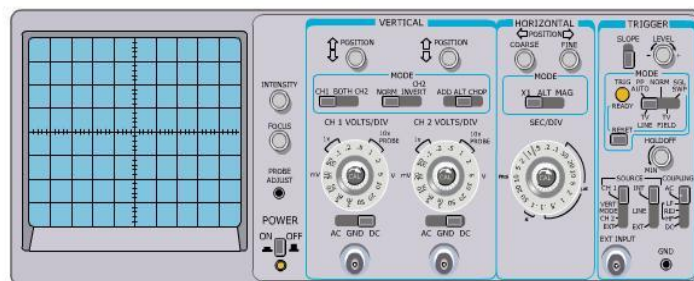

**Fig-3.5: Cathode-ray oscilloscope (CRO)**

## Dual-beam oscilloscope

The dual-beam analog oscilloscope can display two signals simultaneously. A special dual-beam CRT generates and deflects two separate beams. Although multi-trace analog oscilloscopes can simulate a dual-beam display with chop and alternate sweeps, those features do not provide simultaneous displays.



**Fig-3.6: Dual-beam oscilloscope**

## Analog storage oscilloscope

Trace storage is an extra feature available on some analog scopes; they used direct-view storage CRTs. Storage allows the trace pattern that normally decays in a fraction of a second to remain on the screen for several minutes or longer. An electrical circuit can then be deliberately activated to store and erase the trace on the screen.

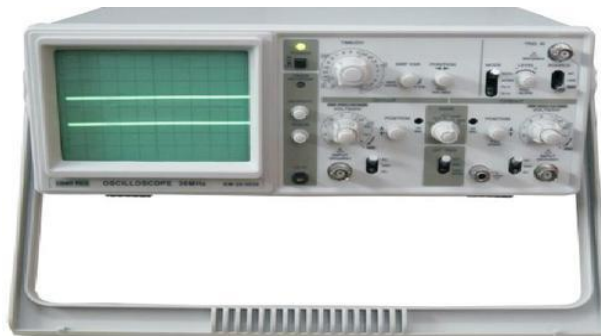

**Fig-3.7.: Analog storage oscilloscope**

## Digital oscilloscope

The digital storage oscilloscope, or DSO for short, is now the preferred type for most industrial applications, although simple analog CROs are still used by hobbyists. It replaces the unreliable storage method used in analog storage scopes with digital memory, which can store data as long as required without degradation.

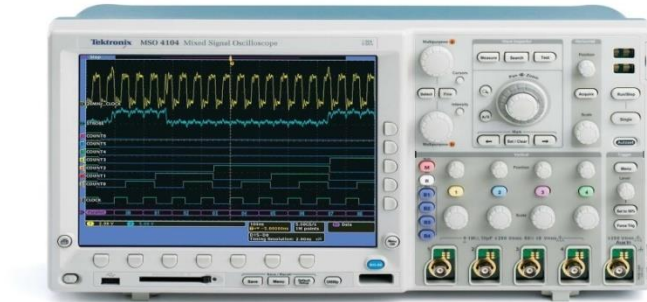

**Fig- 3.8 : Digital oscilloscope**

A digital phosphor oscilloscope (DPO) uses color information to convey information about a sign.

## Mixed-signal oscilloscope

A mixed-signal oscilloscope (or MSO) has two kinds of inputs, a small number of analog channels (typically two or four), and a larger number of digital channels (typically sixteen). It provides the ability to accurately time-correlate analog and digital channels.

## Handheld oscilloscope

A hand held oscilloscope is usually a digital sampling oscilloscope, using a liquid crystal display.



**Fig3.9: Handheld oscilloscope**

### **PC-based oscilloscope**

A new type of oscilloscope is emerging that consists of a specialized signal acquisition board (which can be an external USB or parallel port device, or an internal add-on PCI or ISA card). The user interface and signal processing software runs on the user's computer, rather than on an embedded computer as in the case of a conventional DSO. (Ref: Kularatna, Nihal (2003), "Fundamentals of Oscilloscopes", Digital and Analogue Instrumentation: Testing and Measurement, Institution of Engineering and Technology, pp. 165–208, ISBN 978-0-85296-999-1).

### **3.2.2 Spectrum analyzers**

A spectrum analyzer measures the magnitude of an input signal versus frequency within the full frequency range of the instrument. The primary use is to measure the power of the spectrum of known and unknown signals. The input signal a spectrum analyzer measures is electrical, however, spectral compositions of other signals, such as acoustic pressure waves and optical light waves, can be considered through the use of an appropriate transducer. Optical spectrum analyzers also exist, which use direct optical techniques such as a monochromator to make measurements.



By analyzing the spectra of electrical signals, dominant frequency, power, distortion, harmonics, bandwidth, and other spectral components of a signal can be observed that are not easily detectable in time domain waveforms. These parameters are useful in the characterization of electronic devices, such as wireless transmitters.

The display of a spectrum analyzer has frequency on the horizontal axis and the amplitude displayed on the vertical axis. To the casual observer, a spectrum analyzer looks like an oscilloscope and, in fact, some lab instruments can function either as an oscilloscope or a spectrum analyzer.

### 3.2.2.1 Types

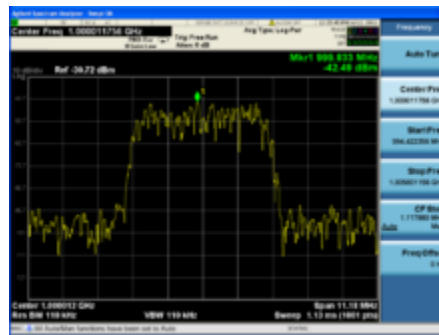

**Fig-3.10: A modern spectrum analyzer display**

Spectrum analyzer types are dictated by the methods used to obtain the spectrum of a signal. There are swept-tuned and FFT based spectrum analyzers:

#### **Swept-tuned spectrum**

A swept-tuned spectrum analyzer uses a super heterodyne receiver to down-convert a portion of the input signal spectrum (using a voltage-controlled oscillator and a mixer) to the center frequency of a band-pass filter. With a super heterodyne architecture, the voltage-controlled oscillator is swept through a range of frequencies, enabling the consideration of the full frequency range of the instrument.

## **FFT spectrum analyzer**

A FFT spectrum analyzer computes the discrete Fourier transform (DFT), a mathematical process that transforms a waveform into the components of its frequency spectrum, of the input signal.

Some spectrum analyzers, such as real-time spectrum analyzers, use a hybrid technique where the incoming signal is first down-converted to a lower frequency using super heterodyne techniques and then analyzed using fast fourier transformation (FFT) techniques. (Ref: The 'Real' History of Real-Time Spectrum Analyzers; Joe Deery, 2007, accessed 10 April 2013.)

### **3.2.3 Logic Probe**

A logic probe is a hand-held pen-like test probe used for analyzing and troubleshooting the logical states (Boolean 0 or 1) of a digital circuit. While most are powered by the circuit under test, some devices use batteries. They can be used on either TTL (transistor-transistor logic) or CMOS (complementary metal-oxide semiconductor) integrated circuit devices.

There are usually three differently-colored LEDs on the probe's body:

- Red and green LEDs indicate high and low states respectively

- An amber LED indicates a pulse (as used in a NOID Light to test for pulses to fuel injectors on an electronically controlled fuel injection vehicle)

The pulse-detecting electronics usually has a pulse-stretcher circuit so that even very short pulses become visible on the amber LED. A control on the logic probe allows either the capture and storage of a single event or continuous running.



**Fig-3.11: A low-cost logic probe**

When the logic probe is either connected to an invalid logic level (a fault condition or a tri-stated output) or not connected at all, none of the LEDs lights up. A logic probe is a cheap, versatile and convenient digital test instrument, but can test only a single signal at a time.

### **3.2.4 Digital Pattern Generator**

A digital pattern generator is a piece of electronic test equipment or software used to generate digital electronics stimuli. Digital electronics stimuli are a specific kind of electrical waveform varying between two conventional voltages that correspond to two logic states ('low state' and 'high state', '0' and '1'). The main purpose of a digital pattern generator is to stimulate the inputs of a digital electronic device.

#### **3.2.4.1 Types of digital pattern generators**

Digital pattern generators are today available as stand-alone units, add-on hardware modules for other equipment such as a [logic analyzer] or as PC-based equipment.

Stand-alone units are self-contained devices that include everything from the user interface to define the patterns that should be generated to the electronic that actually generates the output signal.



**Fig-3.12: Digital Pattern Generator**

Some test equipment manufacturers propose pattern generators as add-on modules for logic analyzers (see for example the PG3A module for Tektronix' TLA7000 series of logic analyzers). In this case, the pattern generator is the 'generation counterpart' to the analysis functionality offered by logic analyzers.

PC-based digital pattern generators are connected to a PC through peripheral ports such as PCI, USB and/or Ethernet (see for example the 'Wave Generator Xpress' from Byte Paradigm, connected through USB). They use the PC as user interface for defining and storing the digital patterns to be sent.

### **3.2.5 LCR meters**

An LCR meter is used to measure the inductance (L), capacitance (C), and resistance (R) of a component.

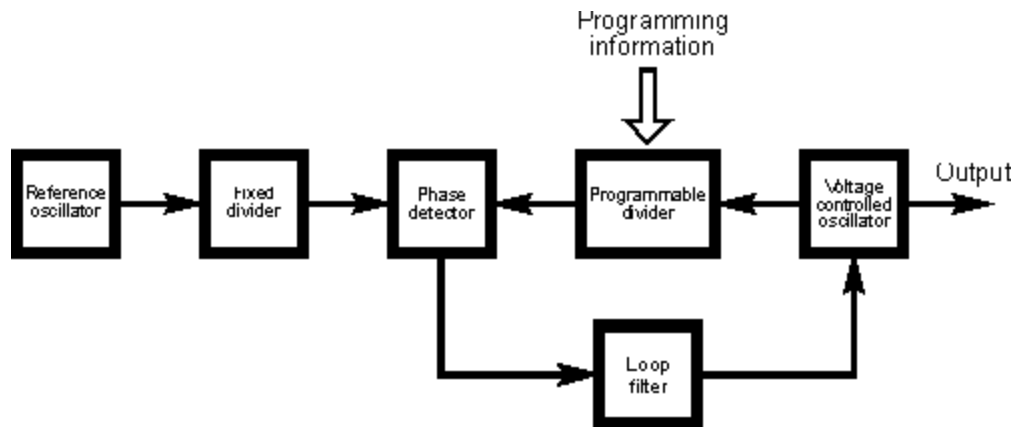

**Fig-3.13: LCR-meter.**

Hand held LCR meters typically have selectable test frequencies of 100 Hz, 120 Hz, 1kHz, 10kHz, and 100kHz for top end meters. The display resolution and measurement range capability will typically change with test frequency

### **3.2.6 Frequency synthesizer**

A frequency synthesizer is an electronic system for generating any of a range of frequencies from a single fixed time base or oscillator. They are found in many modern devices, including radio receivers, mobile telephones, radiotelephones, walkie-talkies, CB radios, satellite receivers, GPS systems, etc. A frequency synthesizer can combine frequency multiplication, frequency division, and frequency mixing (the frequency mixing process generates sum and difference frequencies) operations to produce the desired output signal.



**Fig- 3.14: Digital PLL Frequency Synthesizer**

### 3.2.6.1 Types

Three types of synthesizer can be distinguished. The first and second type are routinely found as stand-alone architecture: Direct Analog Synthesis (also called a mix-filter-divide architecture as found in the 1960s HP 5100A) and by comparison the more modern Direct Digital Synthesizer (DDS) (Table-Look-Up). The third type are routinely used as communication system IC building-blocks: Indirect Digital (PLL) Synthesizers including integer-N and fractional-N. (Ref: Egan, William F. (2000), Frequency Synthesis by Phase-lock (2nd ed.), John Wiley & Sons, ISBN 0-471-32104-4)

# Chapter 4

## Application of electronic measuring instruments

A multimeter used to check for AC or DC voltages, resistance or continuity of electrical components and small amounts of current in circuits. This instrument will let you check to see if there is voltage present on a circuit, etc.

An ammeter measured electric current in a circuit. The majority of ammeters are either connected in series with the circuit carrying the current to be measured or have their shunt resistors connected similarly in series. In either case, the current passes through the meter or through its shunt. They are designed for minimal burden, which refers to the voltage drop across the ammeter, which is typically a small fraction of a volt. They are almost a short circuit. Zero-center ammeters are used for applications requiring current to be measured with both polarities, common in scientific and industrial equipment.

A pulse generator used to generate pulses. The pulses are then injected into the device under test such as a switch so as to determine if it is working well. They are available for generating output pulses that have widths ranging to under one Pico second from one minute down.

An oscilloscope is a diagnostic device that displays a time varying voltage. Like a television, it features a cathode ray tube, which produces an electron beam that sweeps across a fluorescent screen. It is significant because it shows electrical signals in the form of voltage versus time.

A spectrum analyzer determined whether or not a wireless transmitter is working according to federally defined standards for purity of emissions. Output signals at frequencies other than the intended communications frequency appear as vertical lines (pips) on the display. A spectrum analyzer can also be used to determine, by direct observation, the bandwidth of a digital or analog signal. Spectrum analyzers are instruments that are used to receive and select frequency levels based on the super

heterodyne principle. It is very sensitive, converting higher frequencies of up to 10s GHZ into something that is measurable. Received frequencies are first put into a series of pre-selected values. These are then converted into a frequency that is selected to a DC level that is measurable.

A logic probe can be used to provide an indication about the signals on logic lines in digital circuits.

The digital pattern generators can be used for peripheral/ASIC emulation and stimulation, protocol level testing setup/hold verification, production test, mixed signal testing and general digital stimulus. The PG3 can be coupled with a Tektronix Logic Analyzer and/or a Tektronix Digital Oscilloscope to provide a complete test system.



# Chapter 5

## Electronics-related Inventors & their inventions

### John Logie Baird

John Logie Baird (1888-1946) was a pioneer in the development of mechanical television. In 1924, Baird televised objects in outline. In 1925, he televised human faces.



In 1926, Baird was the first person to televise pictures of objects in motion. In 1930, Baird made the first public broadcast of a TV show, from his studio to the London Coliseum Cinema; the screen consisted of a 6-ft by 3-ft array of 2,100 tiny flash lamp bulbs. Baird developed a color television in 1928 and a stereo television in 1946.

Baird's mechanical television was usurped by electronic television, which he also worked on.

### Alexander Graham Bell

Alexander Graham Bell invented the telephone (with Thomas Watson) in 1876. Bell also improved Thomas Edison's phonograph. Bell invented the multiple telegraph (1875), the hydro airplane, the photo-sensitive selenium cell (the photo phone, a wireless phone, developed with Sumner Tainter), and new techniques for teaching the deaf to speak.

### Thomas Alva Edison

Thomas Alva Edison (1847-1931) was an American inventor (also known as the Wizard of Menlo Park) whose many inventions revolutionized the world. His work includes improving the following: the incandescent electric light bulb, the phonograph, the phonograph record, the carbon telephone transmitter, and the motion-picture projector.

Edison experimented with thousands of different light bulb filaments to find just the right materials to glow well, be long-lasting, and be inexpensive. In 1879, Edison discovered that a carbon filament in an oxygen-free bulb glowed but did not burn up for quite a while. This incandescent bulb revolutionized the world.

## **Guglielmo Marconi**

Guglielmo Marconi (1874-1937) was an Italian inventor and physicist. In 1895, Marconi promoted and popularized the radio (wireless telegraphy), building machinery to transmit and receive radio waves. His first transmission across an ocean (the Atlantic Ocean) was on December 12, 1901. Marconi won the Nobel Prize for Physics in 1909.

## **Samuel Finley Breese Morse**

Samuel Finley Breese Morse (1791-1872) was an American inventor and painter. After a successful career painting in oils (first painting historical scenes and then portraits),



Morse built the first American telegraph around 1835 (the telegraph was also being developed independently in Europe).

A telegraph sends electrical signals over a long distance, through wires.

In 1830, Joseph Henry (1797-1878) made the first long-distance telegraphic device - he sent an electric current for over a mile on wire that activated an electromagnet, causing a bell to ring.

## **Edwin Herbert Land**



The Polaroid camera is a camera that develops the photograph while you wait (one-step photography). It was invented by Edwin Herbert Land (1909-1991), an American physicist and inventor who also investigated the mechanisms of color perception, developed the first modern light polarizer's (which eliminate glare), and other optical devices.

## **Nikola Tesla**

The radio was invented by Nikola Tesla. The radio was promoted and popularized by Guglielmo Marconi in 1895. The first radio transmission across an ocean (the Atlantic Ocean) occurred on December 12, 1901.

## **Chester Floyd Carlson**

Xerography (which means "dry writing" in Greek) is a process of making copies that was invented in 1938 by Chester Floyd Carlson (1906-1968). Xerography makes copies without using ink (hence its name). In this process, static electricity charges a lighted plate; a plastic powder (called toner) is applied to the areas of the page to remain white.

# Chapter 6

## Future Inventions of electronics

### 6.1 Quantum computers

These machines work by making direct use of quantum mechanical phenomena, such as superposition and entanglement, to perform operations on data. In addition to being trillions of times faster than earlier computers, they can be made absolutely secure, too. The machines' encryption techniques are virtually unbreakable, due to the almost unimaginable number of instructions being executed simultaneously.

### 6.2 Laptop Antiques

In only a few years time, the invention of the laptop will be on par with us looking back at the invention of the printing press or steamboat. Newborns of today will grow up in a vastly more personally power electronic world than we can even imagine today. And they won't even realize the here and now as we know it.

### 6.3 Flying Cars

At the beginning of a new century, we may see the realization of a century-old dream -- the merging of cars and planes into roadable aircraft, or flying cars. We've probably heard promises about flying cars before, and the technology to make them safe and easy to fly may finally be here.

### 6.4 Needle-less Injection

This future invention is a device for delivering medication and vaccinations through the skin. This new micro-poration technology is painless to use and requires no supervision to administer. The interfaced controls regulate the dosage.

## **6.5 Graphene**

Graphene is widely regarded as the electronics material of the future, but in an article published over the weekend in the journal Nature Nanotechnology, a group from EPFL's Laboratory of Nanoscale Electronics and Structures (LANES) describes how the abundant mineral molybdenite ( $\text{MoS}_2$ ) is a very effective semiconductor with advantages over both graphene and silicon. The discovery could allow for transistors that are smaller and orders of magnitude more efficient.

## **6.6 Zero-size Intelligence**

Computer companies encourage forward-thinking creativity, and some, such as Intel, even have futurists on board to predict where technology is headed. Futurist Brian David Johnson sees the future advance of computing to so small a size that the housing for the computer itself is almost zero. We have the technology to put computers almost anywhere and in almost anything. Computers used to take up entire rooms, then whole desktops, laptops, and palms, to micro-chip sized casings and atom-powered transistors invisible to the naked eye.

## **6.7 Holographic Displays**

For holographic 3D display huge amount of data must be presented. In hardcopy 3D display it is possible to sequentially record such huge information, but electronic holographic display, or electro-holography requires much more efforts to be realized. The information necessary for holographic display is quite huge, the advancements are needed in both processing and displaying such huge information. Especially the spatio-temporal resolution of display device is a critical issue.

## **6.8 Nanotech Computing**

The silicon transistors in our computer may be replaced in ten years by transistors based on carbon nanotubes. This is what scientists at the University of Gothenburg are hoping - they have developed a method to control the nanotubes during production.

The amazing development in computer power that has taken place after the invention of the integrated circuit in the 1950s has been made possible by the transistor, which is the most important component of all processors, becoming ever-faster.

### **6.9 The Sonic Screwdriver**

One of the coolest tool used in the popular sci-fi series *Doctor Who* is the sonic screwdriver (pictured with actor David Tennant). This device allows The Doctor on the series to do everything from opening doors, to altering radio and satellite signals to cutting, burning, welding, healing wounds and much more. And now, British engineers are working on the very first real sonic screwdriver.

### **6.10 The Tricorder**

Dr. Peter Jansen, of the Cognitive Science Laboratory at McMaster University in Hamilton, Ontario, Canada, has developed a measurement device based on the *Star Trek* model. He has been working on his prototype for the tricorder for several years and has stated that his model can take atmospheric measurements, electromagnetic measurements and can make spatial measurements of distance, location or motion.

### **6.11 Robot Soldiers**

DARPA stated that the Avatar program will work on "interfaces and algorithms to enable a soldier to effectively partner with a semi-autonomous bipedal machine and allow it to act as the soldier's surrogate." More or less, this means that the DOD wants to create bipedal robot drones that are controlled by soldiers who are hundreds, or even thousands, of miles away from the war front.

### **6.12 The Land speeder**

The Land speeder consists of a pair of massive propellers and is powered by a central four-stroke engine with a seat on top and a small fuel tank. The right handlebar controls the rotors thrust while the left adjusts the angle of the nose's pitch.

### **6.13 Flexible Displays**

Among the future inventions in e-readers is this paper thin, flexible film that reads like a magazine or newspaper. The GIP (Gate-in-Panel) technology promises to be the next generation in digital display technology competing in the e-book market.

# Chapter 7

## Conclusion

The changes of 20th century are mainly due to electronics. All the systems today are almost electronic. So at last it can be said that the history of electronics is as rich as the electronics itself. Through ages the developments in electronics have started. The future seems to be very bright. The new fields like the quantum communication and bioinformatics are going to be the leading areas of studies in the future which can take the human civilization to a great high. The history of electronics is widespread and cannot be described in a paper of limited words. This paper is just one of the bird's eye views on the history of electronics. Here it has been tried to include almost all the great works and the persons behind them. The discovery of the transistor effect has been considered as the development of the modern electronics. But the trail is mainly to find out what led to the discovery of the transistor and what its after effects are. As the electronic technology is developing faster and faster, many electronic products appear with advanced functions to facilitate, improve and even change the life of the whole society. Among all these electronic products, the computer and smart phone are thought to be most common because of a lot of benefits brought by them and seem to become the necessity in daily life. Because of the above advantages, people tend to devote themselves too much in the electronic products. The concern on electronic addiction therefore arises. An observation of the behaviors of the use of electronic products reveals that people use them abnormally. People spend most of time on the electronic products for entertainment and social relationship. This is actually an implication of addiction. However, the problem of addiction to electronics seems not be recognized by the general public. Hence, people even do not realize the negative effects of the addiction including the psychological and physiological impacts.

# References

- 1) Sōgo Okamura (1994). History of Electron Tubes. IOS Press. p. 5. Retrieved 5 December 2012.
- 2) Frank Spitzer and Barry Howarth, Principles of Modern Instrumentation, Holt, Rinehart and Winston, New York, 1972, ISBN 0-03-080208-3 chapter 11.
- 3) "Fragebogen aus der Personenmappe Friedrich Drexler (1858 - 1945)". Technisches Museum Wien. Retrieved 20130710.Ix Innovations, LLC.
- 4) "Pocket Pico Ammeter Theory of Operation". Retrieved 2010-19-19.
- 5) "AVO". gracesguide.co.uk. Retrieved 2010-11-02.
- 6) Frank Spitzer, Barry Howarth Principles of modern instrumentation, Holt, Rinehart and Winston, 1972 ISBN 0-03-080208-3 pages 32-40
- 7) "Model 2002 Multimeter Specifications". Keithley Instruments.
- 8) "Digital Multimeter Measurement Fundamentals". National Instruments. Retrieved 2008-01-26.
- 9) Milton Kaufman. Handbook of electronics calculations for engineers and technicians. McGraw-Hill.
- 10) Horn, Delton (1993). How to Test Almost Everything Electronic. McGraw-Hill/TAB Electronics. pp. 4–6. ISBN 0-8306-4127-0.
- 11) "A Precision Current Adapter for Multimeters, with explanation of burden voltage (Silicon Chip magazine April 2009)". alternatezone.com. Retrieved 2009-09-22.
- 12) Hewes, John. "Testing a diode with a multimeter". Retrieved 2007-01-28.
- 13) Goldwasser, Samuel. "Basic Testing of Semiconductor Devices". Retrieved 2007-01-28.
- 14) Extech Instruments. "Extech 5 MHz Dual Channel Multiscope". Retrieved 2007-01-28.
- 15) Advance Devices Inc. "Smart Tweezers Digital Multimeter/LCR Meter". Retrieved 2009-01-20.



- 16) Fluke Manufacturing. "Logging and analyzing events with FlukeView Forms Software". Retrieved 2007-01-28.
- 17) "Gauging the impact of DVMs". EETimes.com. Retrieved 2008-01-26.
- 18) Dyer, Stephen (2001). Survey of Instrumentation and Measurement. p. 286. ISBN 0-471-39484-X.
- 19) Wilson, Mark (2008). The ARRL Handbook For Radio Communications. ISBN 0-87259-101-8.
- 20) Frank Spitzer and Barry Horwath Principles of Modern Instrumentation, Holt, Rinehart and Winston Inc., New York 1972, no ISBN, Library of Congress 72-77731, page 39.
- 21) "The Incomplete Idiot's Guide to VTVMs". tone-lizard.com. Retrieved 2007-01-28.
- 22) "Safety Standard IEC 61010-1 since 1.1.2004".
- 23) Safety requirements for electrical equipment for measurement, control and laboratory use. General requirements. 1993. ISBN 0-580-22433-3.
- 24) Dyer, Stephen (2001). Survey of Instrumentation and Measurement. p. 285. ISBN 0-471-39484-X.
- 25) "Anatomy of a high-quality meter". Retrieved 2008-01-26.
- 26) Mullin, Ray (2005). Electrical Wiring: Residential. Thompson Delmar Learning. p. 6. ISBN 1-4018-5020-0.
- 27) Jones, David. "Multimeter Input Fuse Protection". EEVblog. Retrieved 28 December 2012.
- 28) Jones, David. "Multimeter Input Protection Tutorial". EEVblog. Retrieved 28 December 2012.
- Jones, David. "Oscilloscope Trigger Holdoff Tutorial". EEVblog. Retrieved 30 December 2012.
- 29) Webster, John G. (1999). The Measurement, Instrumentation and Sensors Handbook (illustrated ed.). Springer. p. 37-24. ISBN 978-3540648307.

- 30) Take A Peek Inside Today's Spectrum Analyzers; Bob Hiebert, 2005, accessed 10 April 2013.
- 31) The 'Real' History of Real-Time Spectrum Analyzers; Joe Deery, 2007, accessed 10 April 2013.
- 32) Agilent Spectrum Analysis Basics, p. 23, August 2, 2006, accessed July 7, 2011.
- 33) Agilent Spectrum Analysis Basics, p. 22, Figure 2–14, August 2, 2006, accessed July 7, 2011.
- 34) Capacitor Sounds 1 - Low Distortion (sub 1PPM ) 1 kHz Test Oscillator, C Bateman, Electronics World July 2002, expanded March 2003. Description, measurements, circuit, and PCB layout.
- 35) Earl D. Gates (2000). Introduction to Electronics: A Practical Approach. Thomson Delmar Learning. ISBN 0-7668-1698-2.
- 36) Know your Tube and Transistor Testers, Robert G. Middleton.
- 37) Radiomuseum: Electron Tube Curve Tracer 570
- 38) US Lawrence Livermore laboratory, Standby Power, measuring standby
- 39) Joeseph J. Carr, RF Components and Circuits, Newnes, 2002 ISBN 978-0-7506-4844-8 pages 351-370
- 40) Bird, John (2010). Electrical and Electronic Principles and Technology. Routledge. pp. 63–76. ISBN 9780080890562. Retrieved 2013-03-17.
- 41) Keithley, Joseph F. (1999). The Story of Electrical and Magnetic Measurements: From 500 BC to the 1940s. John Wiley & Sons. p. 23. ISBN 9780780311930. Retrieved 2013-03-17.
- 42) Pillai, K. P. P. (1970). "Fringing field of finite parallel-plate capacitors". Proceedings of the Institution of Electrical Engineers 117 (6): 1201–1204.  
doi:10.1049/piee.1970.0232

- 43) Scherz, Paul (2006). Practical Electronics for Inventors (2nd ed.). McGraw Hill Professional. p. 100. ISBN 9780071776448. Retrieved 2013-03-17.
- 44) Bird, John (2007). Electrical Circuit Theory and Technology. Routledge. p. 501. ISBN 9780750681391. Retrieved 2013-03-17.
- 45) Tooley, Mike (2012). Electronic Circuits: Fundamentals and Applications, 3rd Ed.. Routledge. p. 81. ISBN 1-136-40731-6.
- 46) Lowe, Doug (2013). "Electronics Components: Diodes". Electronics All-In-One Desk Reference For Dummies. John Wiley & Sons. Retrieved January 4, 2013.
- 47) "The Constituents of Semiconductor Components". 2010-05-25. Retrieved 2010-08-06.
- 48) "Electronic Valve - AWV, Diode, Type 6AU5GTA". Museum Victoria. Retrieved 9 January 2013.
- 49) "Integrated circuit (IC)". JEDEC.
- 50) Andrew Wylie (2009). "The first monolithic integrated circuits". Retrieved 14 March 2011.
- 51) "Integrated circuits help Invention". Integratedcircuitshelp.com. Retrieved 2012-08-13.
- 52) "Milestones: First Semiconductor Integrated Circuit (IC), 1958". IEEE Global History Network. IEEE. Retrieved 3 August 2011.
- 53) Peter Clarke, Intel enters billion-transistor processor era, EE Times, 14 October 2005.
- 54) Farago, PS, An Introduction to Linear Network Analysis, pp. 18–21, The English Universities Press Ltd, 1961.
- 55) Wu, F Y (2004). "Theory of resistor networks: The two-point resistance". Journal of Physics A: Mathematical and General 37 (26): 6653. doi:10.1088/0305-4470/37/26/004

- 56) James H. Harter, Paul Y. Lin, Essentials of electric circuits, pp. 96–97, Reston Publishing Company, 1982
- 57) Vishay Beyschlag Basics of Linear Fixed Resistors Application Note, Document Number 28771, 2008.
- 58) "Carbon Film Resistor". The Resistorguide. Retrieved 10 March 2013.
- 59) "Electronic components – resistors". Inspector's Technical Guide. US Food and Drug Administration. 1978-01-16. Archived from the original on 2008-04-03. Retrieved 2008-06-11.
- 60) B.G. Yacobi, Semiconductor Materials: An Introduction to Basic Principles, Springer 2003 ISBN 0306473615, pp. 1–3
- 61) Charles Kittel (1995) Introduction to Solid State Physics, 7th ed. Wiley, ISBN 0471111813.
- 62) Lidia Łukasiak and Andrzej Jakubowski (January 2010). "History of Semiconductors". Journal of Telecommunication and Information Technology: 3.
- 63) Peter Robin Morris A History of the World Semiconductor Industry, IET 1990, ISBN 0863412270, pp. 11–25
- 64) Vardalas, John, Twists and Turns in the Development of the Transistor IEEE-USA Today's Engineer, May 2003.
- 65) "Method And Apparatus For Controlling Electric Currents". United States Patent and Trademark Office.
- 66) "Amplifier For Electric Currents". United States Patent and Trademark Office.
- 67) "Device For Controlling Electric Current". United States Patent and Trademark Office.
- 68) "Twists and Turns in the Development of the Transistor". Institute of Electrical and Electronics Engineers, Inc.enerator.

# Appendix

## A. Flow Diagram of Self Consistent Modeling

The whole self-consistent modeling is presented here in flow chart form.

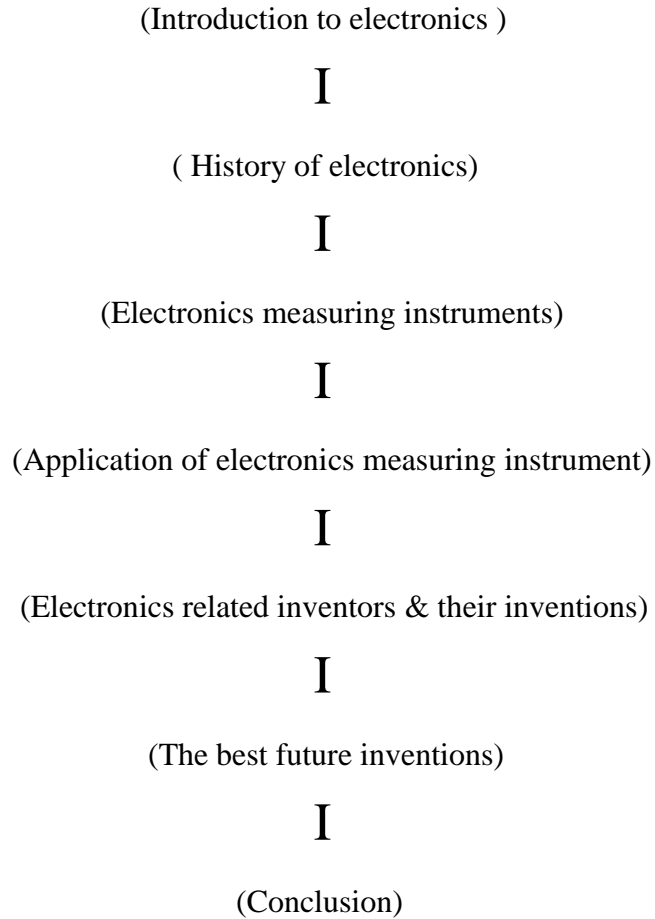

**Figure A.1: Flow diagram of self consistent modeling.**