



Faculty of Engineering
Department of Textile Engineering

Effect of different softeners on moisture absorption and transmission properties of knitted cotton fabric

Course code: TE-407/417 Course title: Project (Thesis)

Submitted by:

Shibasish Roy ID: 073-23-560

Md.Zahidur Rahman ID: 093-23-1624

Tapash Kumar Burman ID: 113-23-2652

Supervised by:

Abu Naser Md. Ahsanul Haque

Senior Lecturer

A thesis submitted in partial fulfillment of the requirements for the degree of
Bachelor of Science in Textile Engineering

Advance in Textile Wet Processing

August, 2015

LETTER OF APPROVAL

July 25, 2015

To

The Head

Department of Textile Engineering

Daffodil International University

102 Sukrabad, Mirpur Road, Dhaka-1207

Subject: Approval of final year project report

Dear Sir

I am just writing to let you know that, this project report titled as “**Effect of different softeners on moisture absorption and transmission properties of knitted cotton fabric**” is completed for final evaluation. The whole report is prepared based on proper investigation and interpretation though critical analysis of empirical data with required belongings. The students were directly involved in their project activities and the report becomes vital to spark off many valuable information for the readers.

Therefore, it will highly be appreciated if you kindly accept this project report and consider it for final evaluation.

Yours Sincerely,



Abu Naser Md. Ahsanul Haque

Senior Lecturer

Department of TE

FE, DIU

DECLARATION

We hereby declare that, this project has been done by us under the supervision of Abu Naser Md. Ahsanul Haque, Senior Lecturer, Department of Textile Engineering, Faculty of Engineering, Daffodil International University. We also declare that, neither this project nor any part of this project has been submitted elsewhere for award of any degree or diploma.

Supervised by:



Abu Naser Md. Ahsanul Haque

Senior Lecturer

Department of Textile Engineering

Daffodil International University

Submitted by:



Shibasish Roy

ID: 073-23-560

Department of Textile Engineering

Daffodil International University



Md. Zahidur Rahman

ID: 093-23-1624

Department of Textile Engineering

Daffodil International University

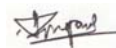

Tapash Kumar

ID: 113-23-2652

Department of Textile Engineering

Daffodil International University

ACKNOWLEDGEMENT

At first all gratefulness goes to the Almighty ALLAH to give us the strength and ability to complete the Thesis (project) and this report.

We are grateful to **Dr. Md. Mahbul Haque**, Head of the department of Textile Engineering for giving us the opportunity to accomplish the project work.

We would like to express sincerest gratitude to our respected teacher **Abu Naser Md. Ahsanul Haque**, Senior Lecturer of Department of Textile Engineering, Daffodil International University for his valuable suggestion, encouragement constructive criticism and for providing all necessary supports to complete our thesis.

We are also expressing special thanks to **Mr. Rasedul Islam Babu**, Textile Engineer of H.H Textile Mills Ltd. for his guidance & advice while doing the practical works for this project. We would like to be thankful to **H.H Textile Mills Ltd.** for their helpful support to this work. We got the most excellent opportunity and consider it a rare fortune to work under them.

Last but not least, thanks go to our precious family for their never ending love and inspire at every stage of our life. Without their continuous support we realize that we would not be a person what we are right now.

ABSTRACT

The influence of softener on different moisture properties were experimented in this project work. Three types of softener (Nonionic, Cationic and Polyethylene emulsion) were selected for this purpose. Results showed that water vapor transmission rate increases with time for all types of softener application but the rate was far lower for the polyethylene emulsion than the others. Moreover, transmission rate increases with the concentration of nonionic softener but decreases in cases of cationic softener. On the other hand, cationic softener showed low moisture regain and moisture content as well as a lower wicking property which influences its lower drying time than the others.

TABLE OF CONTENTS

<u>Contents</u>	<u>Page No.</u>
Letter of Approval.....	ii
Acknowledgement.....	iii
Declaration.....	iv
Abstract.....	v
Table of Contents.....	vi-vii
List of Figures.....	viii
List of Tables.....	ix
CHAPTER 1: INTRODUCTION.....	1-3
CHAPTER 2: LITERATURE REVIEW	4-43
2.1 What is Cotton.....	5
2.1.1 Micro structure of Cotton.....	5-6
2.1.2 Macro structure of Cotton.....	6-7
2.1.3 The Polymer system of Cotton.....	7
2.5 Chemical Composition of Raw cotton	7-8
2.6 Properties of Cotton fiber.....	8-9
2.7 Characteristics of Cotton.....	9
2.9 Physical Properties of Cotton.....	9-12
2.10 Chemical Properties of cotton.....	13
2.2 What is Scouring.....	14
2.3 What is Bleaching.....	14
2.4 What is reactive Dye.....	15
2.5. Moisture Properties	16-17
2.5.3 Relation Between MR& MC.....	17-19
2.5 MR& MC of Different Fiber.....	19-20
5.6 Factors affecting the regain of textile fiber.....	20-22
4.1 Definition of Atmospheric Condition& R.H, Absolute Humidity, Standard atmosphere, Testing Atmosphere, Standard Moisture Regain.....	22-23
2.6 Fabric Conditioning (Softening).....	24-25

2.3 Composition & Different types of Softener.....	25-27
4.4 Softening & Types of Softening.....	46
2.5 Process of Softening.....	28-30
2.6 What is Drying.....	30-33
4.7 Drying Mechanism.....	49
4.8 Method of Drying.....	50-51
4.9 Importance of Drying Conditions.....	50
5.0 What is Wicking Test& Test Method.....	51-52
5.1 What is Moisture Vapors Transmission.....	52
5.2 What is Water Vapors Transmission.....	39
5.3 Factors that influence of Water Vapors Transmission.....	40
5.4 Measurement of Water Vapors Transmission.....	42-43
CHAPTER 3: MATERIALS AND METHODS	45-57
3.1 Materials.....	45
3.2 Methods.....	46
4.2.1 Method of Scouring bleaching.....	46-48
4.2.2 Method of Dyeing	48-49
4.2.3 Method of Softener application.....	49-50
4.2.4 Method of determining MR& MC.....	51
4.2.5 Method of determining drying time.....	52
4.2.6 Method of determining wicking properties.....	53
4.2.7 Method of determining moisture vapor transmission.....	54-56
CHAPTER 4: RESULTS AND DISCUSSIONS	41-45
4.1 Effect of softener on Moisture regain & moisture content.....	59
4.2 Effect of softener on drying time.....	60
4.3 Effect of softener on wicking properties.....	61
4.4 Effect of softener on moisture vapor transmission.....	62
CHAPTER 5: CONCLUSION.....	63
REFERENCES.....	64

LIST OF FIGURES

Figure No.	Title of the Figure	Page No.
Figure 2.1	Cotton ball ready for harvest	5
Figure 2.2	Mature Cotton	5
Figure 2.3	Cross and Longitudinal Section of raw cotton	5
Figure 2.4	Morphological Diagram of Cotton Fiber	6
Figure 2.5	Chemical Structure of raw cotton	7
Figure 2.6	Reactive dye (powder)	15
Figure 2.7	Chemical Structure of reactive dye	16
Figure 2.8	Moisture Regain& Relative Humidity Curve	22
Figure 2.9	Schematic diagram of Softening Process	29

LIST OF TABLES

Table No.	Title of the Table	Page No.
Table 2.5	Chemical Composition of Raw Cotton	10
Table 2.9.1	Length Uniformity of Cotton	14
Table 2.9.2	Fiber Strength	14
Table 2.9.3	Micronair	15
Table 2.9.4	Physical & Chemical Properties of Cotton	25
Table 2.9.5	MR&MC of Different Fiber	36-37
Table 3.1	Specification of Fabric	62
Table 3.2	Lists of Chemicals	62-63
Table 3.3	Name of Equipments	63
Table 3.4	Specification of Machine	63
Table 3.5	MR & MC of fabric sample	68
Table 3.6	Drying time of fabric sample	69
Table 3.7	Wicking test of fabric sample	70
Table 3.8	Moisture Vapor Transmission of fabric sample	71
Table 4.1	Effect of softener on moisture regain and moisture content (graph)	59
Table 4.2	Effect of softener on Drying time (graph)	60
Table 4.3	Effect of softener on wicking properties'(graph)	60
Table 4.3	Effect of softener on moisture vapor transmission (graph)	61

CHAPTER 01
INTRODUCTION

The thermal comfort of clothing can be distinguished in following way:

1. Thermo physiological wear comfort which concerns the heat and moisture transport properties of clothing and the way that clothing helps to maintain the heat balance of the body during various levels of activity.

2. Skin sensational wear comfort which concerns the mechanical contact of the fabric with the skin, its softness and pliability in movement and its lack of prickle, irritation and cling when damp

Thermal comfort is very subjective issue. It is that state when an individual prefers neither warmer nor cooler condition and that condition are comfortable when largest percentage people in any particular grouping are comfortable. It can be defined as “the absence of any unpleasant sensations of being too cool or too warm, or of having too much perspiration on the skin. The thermal comfort of clothing is associated with the thermal balance of the human body and its thermal responses to the dynamic interactions with the clothing and environment systems.

Man, being a homoeothermic, strives to keep his body core at a constant temperature i.e. 37°C and a rise or fall of $\pm 5^\circ\text{C}$ can be fatal. In the cold conditions the blood supply to the extremities is reduced and shivering occurs. In hot days or during high activity level, blood comes to the skin surface to reduce the body temperature. Clothing has a vital part to play in maintaining this heat balance as it modifies the heat loss from the skin surface under the same time has the secondary effect of altering the moisture loss from the skin. The heat balance also varies with climatic conditions. It should be the main property of textiles to conserve the heat that body divers away, and dissipate heat from body surrounding when body generates it. Because of above two different actions, it is impossible to design a single clothing system which acts comfortable to body for all the seasons and reasons. A clothing system which is suitable for one climate may not be suitable for another climate. Good thermal insulation properties are required for clothing and textiles used specially in cold climates. In warm climate, or when the wearer performs hard work, it is important that the clothing transmits the moisture secreted by the body. So it is necessary to understand the mechanism of thermal comfort.

There are five mechanisms like conduction, convection, radiation, evaporation and respiration that allow the body to lose heat to the environment in order to maintain its thermal balance.

In order to keep the wearer dry and hence comfortable, clothing that is worn during vigorous activity, such as sports clothing, has to be able to deal with the perspiration produced by such activity. There are two main properties of clothing that affect the handling of moisture. Firstly there is the ease with which clothing allows the perspiration to be evaporated from the skin surface during the activity. Secondly, after the activity had ceased, there is a need for the moisture that is contained in the clothing layer next to the unnecessarily through having a wet skin. Some workers also consider that the extent to which the wet fabric clings to the skin is also important to the comfort of a garment.

Cotton, the fiber used for our very first blanket at birth, our first pair of pajamas, is often associated to the softness of our childhood and remains an everlasting feeling of comfort. When looking at product labels of clothing, it is always reassuring to see a percentage of cotton in its fiber content. This natural fiber has a very long history as it is probably the first vegetal fiber to be woven into a cloth. Archeologists believe that cotton was used as early as 12 000 BC in Egypt and in Mexico some 7000 years ago. Already at the end of the 16th century AD, cotton was cultivated throughout the world primarily in dry tropical and subtropical climates; cotton fields were found in Africa, Eurasia and the Americas. Cotton contributed significantly to shape the world we live in as it was responsible for the booming US economy in the 18 and 19 centuries.

Cotton, a natural fiber still widely used today because no man-made fiber has ever been able to replace it. It is so natural that when woven into textile, the cotton seeds are still apparent and can only be removed through a special process.

The exceptional properties of cotton in relation to moisture management makes it the most comfortable fabric to wear next to the skin, even before silk which has a tendency to feel cooler. Highly hydrophilic ,the cotton yarn has the ability to take away moisture from the skin leaving it dryer than any other yarn.

CHAPTER 02
LITERATURE REVIEW

2.1 Cotton

Cotton is a soft, staple fiber that grows in a form known as a boll around the seeds of the cotton plant, a shrub native to tropical and subtropical regions around the world, including the Americas, India and Africa. The fiber most often is spun into yarn or thread and used to make a soft, breathable textile. Cotton is the oldest and the most important of the textile fibers. It has been used in the East and Middle East for thousands of years and was found in use in America when the continent was discovered. Despite the increased variety of manufactured fibers available to the textile industry, demand for cotton remains high because of its suitability on the basis of price, quality and comfort across a wide range of textile products.



Fig: 2.1 Cotton ball ready for harvest.



Fig: 2.2 Mature Cotton

2.1.1 The Macro-Structure of Cotton

Under a microscope, a cotton fiber appears as a very fine, regular fiber, looking like a twisted ribbon or a collapsed and twisted tube. These twisted are called convolutions; there are about sixty convolutions per centimeter. The convolutions give cotton an uneven fiber surface, which increases inter fiber friction and enables fiber cotton yarns of adequate strength to be spun.

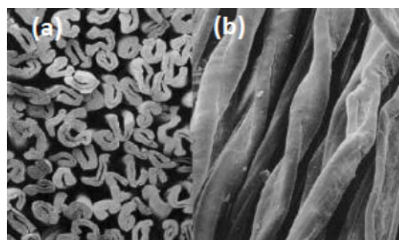

Fig:2.3. Cross & Longitudinal Section of raw cotton

The appearance of the cotton fibers cross-section is referred as being kidney-shaped. These convolution and kidney-shaped cross section of cotton fiber contributes:

- Random contact with the skin which is more compatible with human skin physiology and therefore more comfortable.
- Increase the moisture absorbency due to the countless minute air space because of these convolutions & kidney shape, and thus husk make comfortable to wear.

Cotton fibers are amongst the finest in common use. They have a length from about 10 mm to 65mm, depending upon the quality and diameter in range from about 11 mm to 2 mm. The length to breadth ration of cotton range from about 6000: 1 to about 350: 1. The greater the ration, the more ready can the cotton fibers be sun into yarn. Moreover, yarns from greater fiber length (Sea Island & Egyptian Cotton) shows more luster.

2.1.2 The Microstructure of Cotton

The cotton fiber is a single plant cell. Its cross-section is oval, compared with the normal hexagonal plant cell. Cotton has distinct cuticle, wall developed primary and secondary walls, and a lumen. The cuticle is the very outside of skin of the cotton fiber. It is composed of a waxy layer (cotton wax) only a few molecules thick.

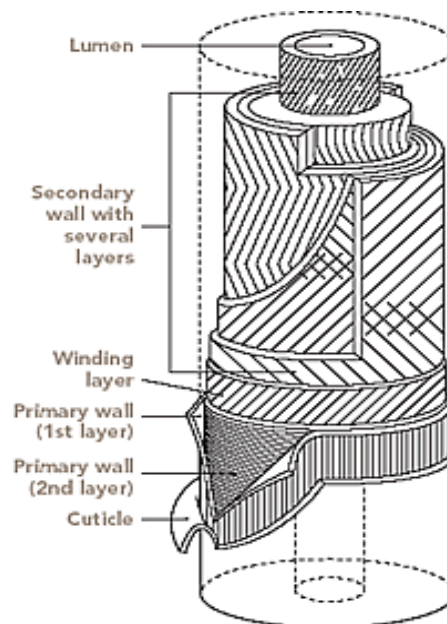

Fig:2.4 Morphological diagram of cotton fiber.

The **primary cell wall**, which is immediately underneath the cuticle, is about 200mm thick and composed of very threads of cellulose, called fibrils, which are 20mm thick. The fibrils spiral about 70° to the fiber axis, hence the primary cell wall can be visualized as a sheath of spiraling fibrils. This spiraling imparts strength of primary cell wall. The **secondary cell wall**, beneath the primary cell wall, forms the bulk of the fiber. Like the growth rings of trees, concentric layers of spinning cellulosic fibrils of about 10mm thick and undefined length, make up the secondary cell wall. The spiral angle is about 20° - 30° to the fiber axis and widens to about 20° - 45° nearer the lumen. The hollow canal, running the length of the fiber, is called the lumen, its walls are the innermost, concentric layovers of spirals of secondary cell wall. The lumen was once the central vacuole of the growing cotton fiber and full of cell-waste products. When the sap evaporated, its constituents' contribute the color of cotton fiber, and the less inside pressure than the atmosphere resulting in kidney shaped cross-section of the cotton fiber.

2.1.3 The Polymer system of cotton

The cotton polymer is a linear, cellulose polymer of 65-70% crystalline and correspondingly 30-35% amorphous. The repeating unit in the cotton polymer is cellulose which consists of two glucose units. Its degree of polymerization (DP) is about 5000. It is about 5000nm in length and about 0.8 nm thick. The most chemical group on the cotton polymer are the hydroxyl groups (-OH), which are also present as methylol groups (-CH₂OH). Their polarity gives rise to hydrogen bonds between the OH-groups of adjacent cotton polymers. Less significant Van der Waals force also occur.

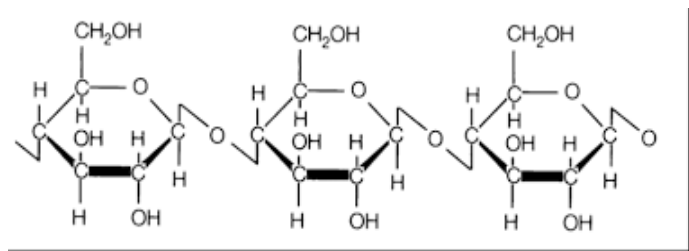

Fig:2.5 Chemical structure of cellulose polymer.

2.5 Chemical Composition of Raw Cotton

Cotton fibers are composed of mostly α -cellulose. The noncellulosics are located either on the outer layers (cuticle and primary cell wall) or inside the lumens of the fibers whereas the secondary cell wall is purely cellulose. The specific chemical compositions of cotton fibers vary by their varieties, growing environments (soil, temperature, etc), and maturity.

Table 2.1: Typical composition of raw cotton

Relation Component	Main Location	Amount (%)
Cellulose	Secondary wall	86.8
Oils, waxes	cuticle	0.7
pectin's	Primary wall	1.0
Carbohydrates	Primary wall	0.5
Proteins	Lumen	1.2
Salts	Lumen	1.0
Water	-	6.8

During manufacture of cotton materials, they are boiled with solutions of NaOH , which serves to emulsify waxes, hydrous fats and proteins, and solubilize mineral salts. Some low molecular weight non-cellulosic carbohydrates are also removed. This alkaline treatment gives a loss in weight of around 7%. The oil and waxes of cotton consists of

- Glycosides', which are readily specifiable oils and fats.
- Waxes, which are saponified with difficulty oils and fats.
- Unsaponifiable oils.
- Free fatty acids and
- Traces of soaps.

2.6 Fiber properties

Fiber length	: 1-5cm
Specific Gravity	: 1.54
Dry Tenacity (g/denier)	: 3.0-4.9
Wet Tenacity (% of Dry)	: 100-110
Tensile Strength(PSI*10)	: 60-120
Elongation at Break(%)	: 3-11
Elastic Recovery (% recovery)	: 75-45
Stiffness (g/denier)	: 57-60
Moisture Regain	: 7.0-8.5
Refractive Index	: 1.54

Others

Resiliency	: low
Abrasion Resistance	: Medium
Dimension Stability	: Medium

2.7 Characteristics of Cotton

Cotton, as a natural cellulosic fiber, has a lot of characteristics, such as;

- Comfortable Soft hand & Good absorbency
- Color retention & Prints well
- Machine-washable & Dry-cleanable
- Good strength, Drapes well & Easy to handle and sew

2.9 Physical Properties of Cotton

Fiber Length

Fiber length is described as "the average length of the longer one-half of the fibers (upper half mean length)" This measure is taken by scanning a "beard " of parallel fibers through a sensing region. The beard is formed from the fibers taken from the sample, clasped in a holding clamp and combed to align the fibers. Typical lengths of Upland cottons might range from 0.79 to 1.36in. Cottons come from the cotton plant; the longer strand types such as Pima or Sea Island produce the finest types of cotton fabrics.

2.9.2 Length Uniformity:

Length uniformity is the uniformity is determine as a ratio between the mean length & the upper half-length of the fiber and is expressed as percentage. Typical comparison are illustrated below:

Length Uniformity	Uniformity Index (%)
Very High	>8.5
High	83-85
Intermediate	80-82
Low	77-79
Very Low	< 79

2.9.3 Fiber Strength

Fiber strength is measured in grams per denier. It is determined as the force necessary to break the beard of fibers, clamped in two sets of jaws, (1/8 inch apart). Typical tensile levels are illustrated. The breaking strength of cotton is about 3.0~4.9 g/denier, and the breaking elongation is about 8~10%.

Degree of Strength	Fiber Strength
Very Strong	>3.1

Strong	29-30
Average	26-28
Intermediate	24-25
Weak	< 23

2.9.4 Micronair

Micronaire measurements reflect fiber fineness and maturity. A constant mass (2.34 grams) of cotton fibers is compressed into a space of known volume and air permeability measurements of this compressed sample are taken. These, when converted to appropriate number, denote Micronaire values.

Cotton Range	Micronair Rating
Premium	3.7-4.2
Base Range	4.3-4.9
Discount Range	< 5

2.9.5 Color

The color of cotton samples is determined from two parameters: degree of reflectance (Rd) and yellowness (+b). Degree of reflectance shows the brightness of the sample and yellowness depicts the degree of cotton pigmentation. A defined area located in a Nickerson-Hunter cotton colorimeter diagram represents each color code.

Work at the University of Tennessee has led to color measurement using both spectrometer CIE-based average color measurement and a color uniformity measurement using image analysis to improve the accuracy and provide additional measurement for color grading. Later the investigators developed two color grading systems using expert system and neural networks.

2.9.6 Trash

A trash measurement describes the amount of non-lint materials (such as parts of cotton plant) in the fiber. Trash content is assessed from scanning the cotton sample surface with a video camera and calculating the percentage of the surface area occupied by trash particles. The values of trash content should be within the range from 0 to 1.6%. Trash content is highly correlated to leaf grade of the sample.

2.9.7 Leaf Grade

Leaf grade is provided visually as the amount of cotton plant particles within the sample. There are seven leaf grades (#1-#7) and one below grade (#8).

2.9.8 Neps

A nep is a small tangled fiber knot often caused by processing. Neps can be measured by the AFIS nep tester and reported as the total number of neps per 0.5 grams of the fiber and average size in millimeters. Nep formation reflects the mechanical processing stage, especially from the point of view of the quality and condition of the machinery used.

2.9.9 Oxy-cellulose

Also, cotton can degrade by exposure to visible and ultraviolet light, especially in the presence of high temperatures around 250~397° C and humidity. Cotton fibers are extremely susceptible to any biological degradation.

2.9.10 Optical Properties of cotton

Cotton fibers show double refraction when observed in polarized light. Even though various effects can be observed, second order yellow and second order blue is characteristic colors of cellulosic fibers. A typical birefringence value as shown in the table of physical properties, is 0.047.

2.9.11 Cotton Classification

Cotton classification is used to determine the quality of the cotton fiber in terms of grade, length and Micronaire. USDA classification specifically identifies the characteristics of fiber length, length uniformity, strength, Micronaire, color, preparation, leaf and extraneous matter. In the past, these qualities were classified just by hand-and-eye of an experienced classer. Since 1991, all classification has been carried out with a set of up-to-

date instruments, called "HVI"(High Volume Instrumentation) classification. However, measuring techniques of other qualities of cotton fiber, such as fiber maturity and short fiber content, are also being developed.

2.10 Chemical Properties of Cotton

2.10.1 Effect of Acid

Cotton is weakened and destroyed by the effect of acids, Hydrolyse the glycoside linkage of oxygen atom. Concentrated Nitric acid, for short time, causes some shrinkage and increase strength and dye ability.

2.10.2 Effect of alkali

Normally resistant, when boiled in presence of O_2 , oxycellulose form. Treatment with 20% $NaOH$ increase strength & dye ability. Liquid ammonia treatment increase strength, elongation etc. Both of solution is used as mercerizing liquor.

2.10.3 Effect of bleach

All kinds of bleaching agents have its action on cotton. $NaOCl$ & Na -per borate are common. H_2O_2 is least harmful.

2.10.4 Effect of organic solvent

Cotton is resistant to organic solvent. So dry wash is possible.

2.10.5 Effect of Heat

Conductive ironing temperature $150^{\circ}C$, Decomposition at $240^{\circ}C$. Ignition temperature $39^{\circ}C$.

2.10.6 Effect of Sunlight

Affected by infrared cause deteriorates color because yellow.

2.10.7 Dye ability

Azoic, Direct, Reactive, Sulphure and Vat dyes are applicable to cotton substrates.

2.10.8 Attack by moth

No

2.10.9 Attack by mildew

untreated not easy but starches and gums increase activity.

2.2 Scouring

Scouring is a process of removing the impurities such as oil, wax, fats, dust and dirt from the textile materials to make it hydrophilic. After scouring process it become possible to get clean material.

Objectives of Scouring:

- To make the textile material highly hydrophilic
- To remove the impurities such as oil, wax, fat, dust, dirt and husk from the material
- To increase the absorbency of the material
- To produce a clean material
- To make the material ready for the next process

2.3 Bleaching

Bleaching is the destruction of natural colorings matters to produce a white material and must be accomplished with a minimum damage to the cotton being bleached. Bleaching is not cleaning process in the sense of scouring, as this process does not remove dusts, dirt's etc.

Objectives of bleaching:

- To impart pure, permanent and basic white effect to the fibre
- To destroy the natural coloring matters from the textile materials

- To make the textile materials suitable for the subsequent processes such as dyeing, printing, finishing etc

2.4 Reactive dye

A dye, which is capable of reacting chemically with a substrate to form a covalent dye substrate linkage, is known as reactive dye.

Here the dye contains a reactive group and this reactive group makes covalent bond with the fiber polymer and act as an integral part of fiber. This covalent bond is formed between the dye molecules and the terminal –OH (hydroxyl) group of cellulose fibers on between the dye molecules and the terminal –NH₂ (amino) group of poly-amide or wool fibers.

Reaction:

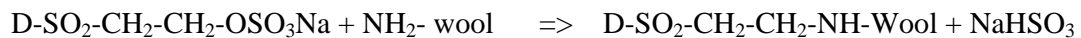
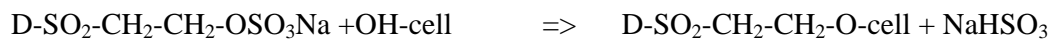

Here, D= dye part.

Wool = wool polymer.

Cell = cellulosic polymer.



Fig: 2.6. Reactive Dye (powder)

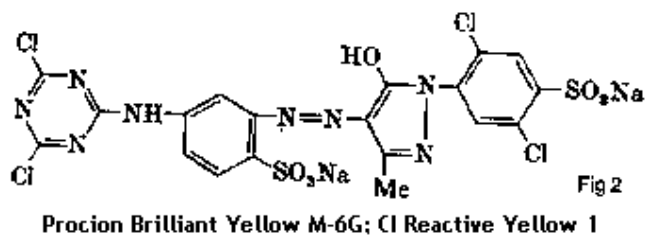

Fig: 2.7. Chemical structure of reactive dye.

2.5 Moisture properties

2.5.1 Moisture Regain (MR):

Moisture Regain is defined as the weight of water in the material expressed as a percentage of the oven dry weight.

Let, Oven dry weight = D

Weight of water = W (Original weight-Oven dry weight)

Moisture Regain = MR or R

Then, Moisture Regain (R%) = $100W/D$

2.5.2 Moisture Content (MC):

Moisture content is defined as the weight of water in the material expressed as percentage of the total weight.

Let, Oven dry weight = D

Weight of water = W (Original weight-Oven dry weight)

Moisture Content = MC or C

Then,

$$\text{Moisture Content} = 100W / (D+W)$$

2.5.3 Relation between moisture regain and moisture content:

The amount of moisture in a sample of material may be expressed in terms of Regain or Moisture content. Regain is defined as the weight of water in a material expressed as a percentage of the oven dry weight. Moisture content is the weight of water in a material expressed as percentage of the total weight.

Let,

Oven dry weight = D

Weight of water = W

Regain = R

Moisture content = M or C

For moisture regain:

$$R = \frac{100w}{D} \dots\dots\dots (1)$$

For moisture content:

$$C = \frac{100w}{D+W} \dots\dots\dots (2)$$

From equation (1)

$$D = \frac{100w}{R}$$

$$C = \frac{100w}{\frac{100w}{R} + W}$$

$$C = \frac{100w}{w(1 + \frac{100}{R})}$$

$$C = \frac{100}{1 + \frac{100}{R}}$$

$$C = \frac{100}{\frac{R+100}{R}}$$

$$C = \frac{100R}{R+100}$$

$$RC+100C = 100R$$

$$100C = 100R - RC$$

$$100C = R(100-C)$$

$$\frac{100C}{100-C} = R$$

$$R = \frac{100C}{100-C} \dots \dots \dots (3)$$

Equation 3 is moisture regain and content relationship.

5.5 Moisture Regain and Moisture Content of different fibers:

Table: 2

Fiber	Moisture Regain (MR %)	Moisture Content (MC %)
Cotton	8.5	7.834
Silk	11	9.91
Polyester	0.4	0
Viscose	11	9.91
Nylon	4	3.1
Flax	12.4	10.4
Cellulose acetate	6	0
Acrylic	1.5	0
Sisal& Manilla	12	0

Wool (carbonized)	17	13.8
Scoured Wool	16	13.8
Jute	13.75	12.1
Hemp	12.4	10.4

5.6 Factors Affecting the Regain of Textile Fiber

Different fiber types absorb different amounts of moisture depending on their affinity for water as shown in Fig.

There are different factors that effects the moisture regain of the textile materials, such as;

1. Relative Humidity
2. Time
3. Temperature
4. The Previous History of The Sample

Relative Humidity: Relative humidity is the most important factor that affects the regain of textile materials. The higher the relative humidity of the atmosphere, the higher is the regain of textile material which is exposed to it. If the relative humidity in the air is more then there will be more moisture regain or more rate of conditioning of textile materials and vice versa.

Time: Material that is in equilibrium at a particular relative humidity which is then moved to an atmosphere with a different relative humidity takes a certain amount of time to reach a new equilibrium. The time taken depends on the physical form of the material and how easily the moisture can reach or escape from the individual fibres. For example the British Standard for count testing suggests a period of one hour for yarn in hank form to reach equilibrium, but three hours for yarn on packages.

A material placed in a given atmosphere takes a certain time to reach equilibrium. The rate of conditioning depends on several factors, such as;

- The size and form of sample
- The type of material
- External conditions

Temperature: The effect of temperature on regain is not important. A change of 10 °C will give a change in regain of cotton of about 0.3 percent. This effect can be ignored. Now we can say that for practical purposes the temperature does not affect the regain of a sample.

6.0 The previous history of the sample: The previous history of the sample can affect the equilibrium regain of the sample. The hysteresis is a good example. Processing can also change the regain. When oils, waxes and other impurities are removed then regain may change.

Different moisture content depending on whether it was previously wet or dry. Processing of the material can also change its regain value by altering its ability to absorb moisture. The removal of oils, waxes and other impurities can also change the regain by removing a barrier on the fibre surface to the flow of moisture vapour. For example the standard regain value for scoured wool is 16% and that for oil combed tops is 19%.

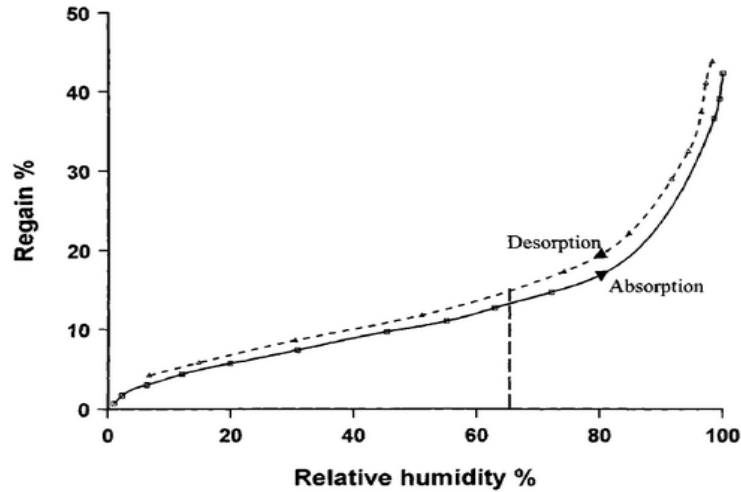

A plot of regain versus relative humidity for viscose fibers

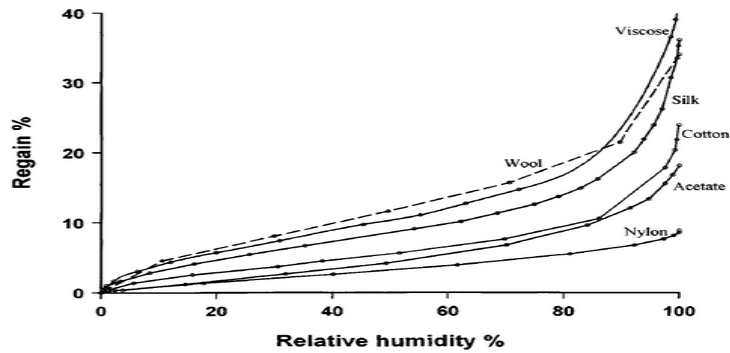

A comparison of the moisture uptake of fibers

Fig: 2.8 Moisture regain and Relative Humidity

6.2 Atmospheric conditions and relative humidity: The regain of a textile material depends upon the amount of moisture present in the surrounding air. The dampness of the atmosphere can be described in terms of humidity, either absolute humidity or relative humidity.

6.3 Absolute humidity: The weight of a water in a unit volume of moist air, i. e, grains per cubic foot or grams per cubic meter.

6.4Relative humidity: The ratio of the actual vapour pressure to the saturated vapour pressure at the same temperature, expressed as a percentage.

$$R.H = \text{actual vapour pressure} / \text{saturated vapour pressure} * 100\%$$

An alternative definition for relative humidity is the ratio of the absolute humidity of the air to that of air saturated with water vapour at the same temperature and pressure. The ratio may then be expressed as a percentage. At ordinary temperature such as those at which processing and testing are carried out, the two ratios are most identical. It is convenient to describe a given atmosphere in term of relative humidity rather than absolute humidity because the regain of textile materials appears to depend upon the relative humidity rather than the actual amount of water vapors present. Since the relative humidity affects the regain of a textile material, and since the properties of the materials are influenced by the regain, it is necessary to specify the atmospheric conditions in which testing should be carried out.

6.5Standard Moisture Regain: The moisture absorbed by a particular weight sample in standard atmosphere after treating at $105 \pm 3^{\circ}\text{C}$ is called Standard Moisture Regain. It is also called official regain.

6.6Standard atmosphere: This is defined as an atmosphere at the pre vailing barometric pressure with a relative humidity of 65 per cent and a temperature of 20°C (68°F).

6.7Testing atmosphere: An atmosphere for testing is specified as one with a relative humidity of 65 per cent plus or minus 2 per cent and a temperature $20^{\circ}\text{C} \pm 2^{\circ}\text{C}$ ($68^{\circ} \pm 4^{\circ}\text{F}$).

In a tropical or subtropical regions the difficulties of achieving a temperature of 20°C are understood and so a higher standard temperature may be used $27^{\circ} \pm 2^{\circ}\text{C}$ ($81^{\circ} \pm 4^{\circ}\text{F}$).

2.6 Fabric softener

Fabric softener is a chemical compound that prevents static cling and confers many other desirable properties to laundry that has been machine-washed. They are available as solutions and solids, sometimes impregnated in "dryer sheets."

Fabric softener is a product used while laundering to make clothes soft and eliminate static cling. Depending on the brand one purchases, it can be added at the beginning of the laundry cycle at the same time detergent is dispensed or during the rinse cycle. It can also come in sheets to be placed in the dryer.

The benefits of using a fabric softener are many. For instance, it reduces static cling. After using it, socks don't stick to sweaters when they're taken out of the dryer and all who come in contact with you won't receive an electric shock. It also reduces wrinkles in clothes. Some materials will still have to be ironed, but adding a little to your laundry will help reduce the amount of wrinkles your laundry usually has. Many busy housekeepers appreciate any time that can be saved on chores such as ironing.

Of course, fabric softener makes clothes feel better too. This is very apparent on laundry items such as towels and sheets, especially those that are hung outside. When this product isn't used, these items tend to feel stiffer. Who doesn't want to crawl between a nice soft set of sheets or dry off with a fluffy towel? The fabrics we use on a daily basis shouldn't be abrasive.

Fabric softeners work by coating the surface of the washed fabric with a thin layer of chemical compounds that are electrically conductive, thus preventing buildup of static charge and improving their feel. Other functions are improvements of iron glide during ironing, increased stain resistance, and reduction of wrinkling and pilling. They also reduce the drying time for clothes, saving energy. Many contain fragrances. Cationic fabric softeners are added to the final step of the wash cycle, lest they interact with the detergents used in the actual cleaning.

Other compounds may be included in the formulation of fabric softeners, e.g., to provide additional functions; acids or bases for maintaining the optimal pH for absorption to the

fabric, electrolytes, carriers (usually water, sometimes water-alcohol mixture), and others, e.g. silicone-based anti-foaming agents, emulsion stabilizers, fragrances, and colors. A relatively recent form on the market are the ultra-concentrates, where the amount of carriers and some other chemical compounds is substantially lower and much smaller volumes are used.

Cationic softeners bind by electrostatic attraction to the negatively charged groups on the surface of the fibers and neutralize their charge; the long aliphatic chains are then oriented towards the outside of the fiber, imparting lubricity.

6.9Composition: Early cotton softeners were typically based on water emulsion of soap and olive oil, corn oil, or tallow oil. The softening compounds differ in affinity to different materials. Some are better for cellulose-based fibers (i.e., cotton), others have higher affinity to hydrophobic materials like nylon, polyethylene terephthalate, polyacrylonitrile, etc. Silicone-based compounds such as polydimethylsiloxane, comprise the new softeners which work by lubricating the fibers. Derivatives with amine- or amide-containing functional groups are used as well. These groups help the softeners bind better to fabrics.

As the softeners themselves are often hydrophobic, they are commonly occurring in the form of an emulsion, In the early formulations, soaps were used as emulsifiers, The emulsions are usually opaque, milky fluids. However there are also microemulsions where the droplets of the hydrophobic phase are substantially smaller. The advantage of microemulsions is in the increased ability of the smaller particles to penetrate into the fibers. A mixture of cationic and non-ionic surfactants is often used as an emulsifier. Another approach is using a polymeric network, an emulsion polymer.

In the 1950s, distearyldimethylammonium chloride (DHTDMAC), was introduced as a fabric softener initially to counteract the harsh feel that the machine washing imparted to diapers. This compound was discontinued because the cation biodegrades very

slowly. Contemporary fabric softeners tend to be based on salts of quaternary ammonium cations. Characteristically, the cations contain one or two long alkyl chains derived from fatty acids. Other cationic compounds can be derived from imidazolium substituted amine salts, or quaternary alkoxy ammonium salts.

As a general rule, the softening agents applied are hygroscopic or lubricating agents, which facilitate the fibre sliding within the fabric structure, thus granting easier deformation and creasing of the fabric. In most cases, the duration of the effect is limited since the products applied during the treatment are eliminated by subsequent washing; for this reason they must be applied in the final stage of the treatment. The most common softeners are below:

1. Non-ionic Softener
2. Anionic Softener
3. Cationic Surfactants
4. Silicone-Based Softeners
5. Reactive Softeners

7.0 Non-ionic Softeners: Generally ethers and polyglycol esters, oxiethylates products, paraffin's and fats. These softening agents are generally less efficient than anionic and cationic ones but they withstand the effects of hard waters, acid or basic environment and also in presence of cations and anions, therefore the normal fabric care conditions.

7.1 Anionic Softeners: Sulphoricinates, anionic surfactants produced by the condensation of fatty acids. They have good characteristics as lubricating softening agents and give the fabric a full hand; they are unstable in hard water and acid environment. In addition, they must not cause yellowing at condensation temperature.

7.2 Silicone-Based Softeners: These are generally polysiloxane derivatives of low molecular weight. They are insoluble in water, and therefore must be applied on fabrics

after dissolution in organic solvents, or in the form of disperse products. They feature quite good fastness to washing. They create a lubricating and moderately waterproof film on the surface and give fabrics a velvety silky hand (desirable for velvets, upholstery fabrics and emerised fabrics).

7.3 Reactive Softeners: N-methylol derivatives of superior fatty amides or urea compounds replaced with fatty acids. The products have to be cross-linked and provide permanent softness and water repellency.

As explained previously, even though some softeners can be applied with exhaustion processes on yarns, when softening fabrics, the best technique is the continuous pad-wetting process followed by a drying stage in a stenter. This treatment must be carried out at the end of the finishing process; for this reason, softening is usually performed simultaneously with other dimensional stability processes (width stabilisation, weft and warp straightening). It is worth remembering that the use of softeners can reduce the fastness to rubbing of synthetic fibres dyed with disperse dyes, as the fatty surface layer tend to attract the dye molecules after hot treatments.

7.4 Cationic fabric softeners: In the 1950s, distearyl dimethylammonium chloride (DHTDMAC) was introduced as a fabric softener initially to counteract the harsh feel that the machine washing imparted to diapers. This compound was discontinued because the cation biodegrades very slowly. Contemporary fabric softeners tend to be based on salts of quaternary ammonium cations. Characteristically, the cations contain one or two long alkyl chains derived from fatty acids. Other cationic compounds can be derived from imidazolium, substituted amine salts, or quaternary alkoxy ammonium salts.

7.5 Anionic fabric softeners: Anionic softeners and antistatic agents can be, for example, salts of monoesters and diesters of phosphoric acid and the fatty alcohols. These are often used together with the conventional cationic softeners. Cationic softeners are incompatible with anionic surfactants used in detergents because they combine with them to form a solid precipitate. So, they must instead be added during the rinse cycle. Anionic softeners can be combined with anionic surfactants directly. Other anionic softeners can

be based on smectite clays. Some compounds, such as ethoxylated phosphate esters, have softening, anti-static, and surfactant properties.

7.6 Softening

As a general rule, each fiber has its specific softness value, which depends on its chemical composition and physical structure (less crystallinity = greater softness). The fineness of the fiber or of the filament directly affects the softness of the yarn (woolens, worsteds, microfibers etc.). The yarn twist ratio is inversely proportional to its softness. The weave also contributes to reducing (closer weave = cloth) or increasing (looser weave = satin) the fabric softness. Furthermore, a greater number of yarns per centimeter increase the stiffness of the fabric, thus reducing its softness. Softening is carried out when the softness characteristics of a certain fabric must be improved, always carefully considering the composition and properties of the substrate. It is also worth underlining that no standard methods have been developed and established to determine exactly what the softness of a fabric is. This evaluation is therefore almost personal and carried out on the basis of operator's experience. It is any way possible to distinguish between many types of **soften**:

- a) surface softness,
- b) surface smoothness,
- c) elasticity (to compression and stretching).

7.7 Fabric Softening Process:

To change the hand properties of a fabric, we can apply mechanical, physical, chemical or combined techniques; some of these methods (sueding, raising) have already been explained in detail in previous sections of this handbook, while some others refers to machines that give different degrees of softness, by means of high-speed rope processing in wet or dry conditions, with the drying stage carried out during the treatment (with or without softeners or enzymes.)

The functional core of these machines are the two tunnels where the fabric is fed through two Venturi tubes. The energy applied for drawing the material is produced only by air and pressure. The fabric flowing through the venturi tubes is pushed at high speed against a grid on the machine rear side; the fabric then slides on Teflon-coated chutes and reaches the machine front side to start the cycle again; the fabric can reach a speed of 1000 m/min., depending on the type and weight of the different textiles to be processed and according to the desired results.

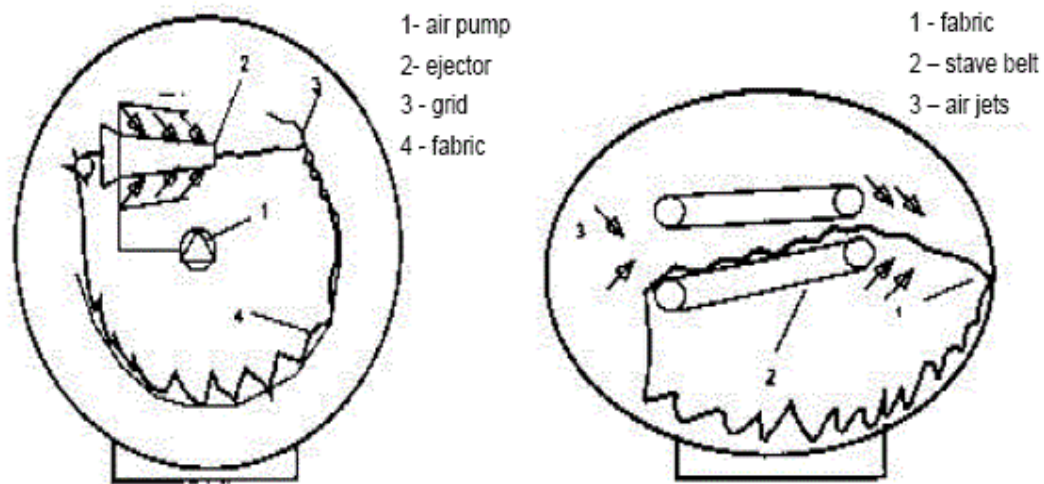

Fig2.8:..Schemes of fabric softening machines

This unit applies physical and mechanical principles on fundamental elements such as:

- air, which is the fabric propeller and drawing element;
- the mechanical stress exerted on the fabric inside the Venturi tubes and the stress due to the impact against the rear grid;
- the eventual action of heat.

It is also worth noticing that water is not a crucial element for the process; it is only a medium for carrying dissolved non biodegradable chemical additives (if required.) The combination of all these elements, almost free of polluting charge, cause the structural modification of the fibres making up the fabric.

They result in more or less marked surface modifications, which can radically change the appearance and the sensorial properties of the fabrics. The complexity of the finishing action starts inside the Venturi tube where the tail of the fabric is subjected simultaneously to a compressive action and to a subsequent series of vibrating pulses which tend to "random-modify" and compact the textile structures, eventually giving them different properties.

The one-way thrusting force is transformed into a impact force against the grid on which the fabric is pushed when emerging from the Venturi tube; this causes other modifications of the fabric and add structural and surface effects.

This simple treatment that combines physical and mechanical principles, carried out at a precise temperature set by the operator, is sufficient to create particular effects on the morphology of fibres and the weave. The modifications produced by this treatment are very different and not only affect the colour, appearance and hand properties of the fabric, but also add new properties, e.g. modifying the refraction and diffraction of light on the fabric-surface.

The most notable effects in terms of style and added value are obtained on linen, a precious delicate fibre, particularly difficult to process without using chemicals.

The combination of a chemical product or an enzyme liquor with the mechanical treatment can be carried out not only on linen but also on many other widely used fibres such as Tencel and polynosic fibres, imparting a draping, full and lively hand.

All these effects are obtained thanks to the air thrust and to the following impact against the grid, or to the pressure of rollers on the fabric rope. Comparing the effects of this treatment on a Tencel fabric and on a similar treatment carried out on a dyeing machine, we can see that, as previously explained, this finishing process not only affects the appearance of the fabric, but also .cleans up. the fabric surface homogeneously, as a result providing good anti-pilling properties.

2.7 Drying

Drying is a mass transfer process consisting of the removal of water or another solvent by evaporation from a solid, semi-solid or liquid. This process is often used as a final production step before selling or packaging products. To be considered "dried", the final product must be solid, in the form of a continuous sheet (e.g., paper), long pieces (e.g., wood), particles (e.g., cereal grains or corn flakes) or powder (e.g., sand, salt, washing powder, milk powder). A source of heat and an agent to remove the vapor produced by the process are often involved. In bioproducts like food, grains, and pharmaceuticals like vaccines, the solvent to be removed is almost invariably water. Desiccation may be synonymous with drying or considered an extreme form of drying.

In the most common case, a gas stream, e.g., air, applies the heat by convection and carries away the vapor as humidity. Other possibilities are vacuum drying, where heat is supplied by conduction or radiation (or microwaves) while the vapor thus produced is removed by the vacuum system. Another indirect technique is drum drying (used, for instance, for manufacturing potato flakes), where a heated surface is used to provide the energy, and aspirators draw the vapor outside the room. In contrast, the mechanical extraction of the solvent, e.g., water, by centrifugation, is not considered "drying" but rather "draining".

Drying mechanism

In some products having a relatively high initial moisture content, an initial linear reduction of the average product moisture content as a function of time may be observed for a limited time, often known as a "constant drying rate period". Usually, in this period, it is surface moisture outside individual particles that is being removed. The drying rate during this period is mostly dependent on the rate of heat transfer to the material being dried. Therefore, the maximum achievable drying rate is considered to be heat-transfer limited. If drying is continued, the slope of the curve, the drying rate, becomes less steep (falling rate period) and eventually tends to nearly horizontal at very long times. The product moisture content is then constant at the "equilibrium moisture content" where it is, in practice, in equilibrium with the dehydrating medium. In the falling-rate period, water migration from the product interior to the surface is mostly by molecular diffusion, i.e. the water flux is proportional to the moisture content gradient. This means that water moves from zones with higher moisture content to zones with lower values, a phenomenon explained by the second law of thermodynamics. If water removal is

considerable, the products usually undergo shrinkage and deformation, except in a well-designed freeze-drying process. The drying rate in the falling-rate period is controlled by the rate of removal of moisture or solvent from the interior of the solid being dried and is referred to as being "mass-transfer limited".

Methods of drying

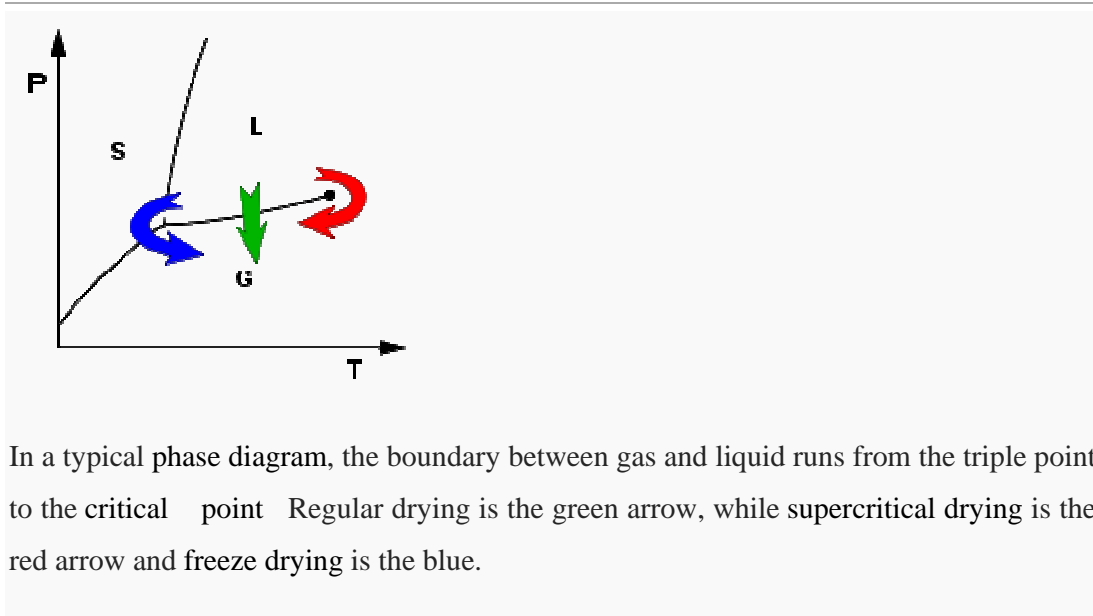

In a typical phase diagram, the boundary between gas and liquid runs from the triple point to the critical point. Regular drying is the green arrow, while supercritical drying is the red arrow and freeze drying is the blue.

The following are some general methods of drying:

Application of hot air (convective or direct drying). Air heating increases the driving force for heat transfer and accelerates drying. It also reduces air relative humidity, further increasing the driving force for drying. In the falling rate period, as moisture content falls, the solids heat up and the higher temperatures speed up diffusion of water from the interior of the solid to the surface. However, product quality considerations limit the applicable rise to air temperature. Excessively hot air can almost completely dehydrate the solid surface, so that its pores shrink and almost close, leading to crust formation or "case hardening", which is usually undesirable. For instance in wood (timber) drying, air is heated (which speeds up drying) though some steam is also added to it (which hinders drying rate to a certain extent) in order to avoid excessive surface dehydration and product deformation owing to high moisture gradients across timber thickness. Spray drying belongs in this category.

Indirect or contact drying (heating through a hot wall), as drum drying, vacuum drying. Again, higher wall temperatures will speed up drying but this is limited by product degradation or case-hardening, Drum drying belongs in this category.

Dielectric drying (radiofrequency or microwaves being absorbed inside the material) is the focus of intense research nowadays. It may be used to assist air drying or vacuum drying. Researchers have found that microwave finish drying speeds up the otherwise very low drying rate at the end of the classical drying methods.

Freeze drying or lyophilization is a drying method where the solvent is frozen prior to drying and is then sublimed i.e., passed to the gas phase directly from the solid phase, below the melting point of the solvent. It is increasingly applied to dry foods, beyond its already classical pharmaceutical or medical applications. It keeps biological properties of proteins, and retains vitamins and bioactive compounds. Pressure can be reduced by a high vacuum pump (though freeze drying at atmospheric pressure is possible in dry air). If using a vacuum pump, the vapor produced by sublimation is removed from the system by converting it into ice in a condenser, operating at very low temperatures, outside the freeze drying chamber.

Supercritical drying (superheated steam drying) involves steam drying of products containing water. This process is feasible because water in the product is boiled off, and joined with the drying medium, increasing its flow. It is usually employed in closed circuit and allows a proportion of latent heat to be recovered by recompression, a feature which is not possible with conventional air drying, for instance. The process has potential for use in foods if carried out at reduced pressure, to lower the boiling point.

Natural air drying takes place when materials are dried with unheated forced air, taking advantage of its natural drying potential. The process is slow and weather-dependent, so a wise strategy "fan off-fan on" must be devised considering the following conditions: Air temperature, relative humidity and moisture content and temperature of the material being dried. Grains are increasingly dried with this technique, and the total time (including fan off and on periods) may last from one week to various months, if a winter rest can be tolerated in cold areas.

8.2 The Importance of Drying Conditions

Ensuring the finish is sufficiently dried before recoating or allowing traffic across the floor is very important to a beautiful and lasting wood floor finish. It is true that water-based coatings are noted for their fast drying times compared to oil-modified urethane finishes but it must be kept in mind that although it is fast there are limitations. Dry times and recoat times are stated in manuals and these are meant to be a guide only because the actual dry time can vary significantly. There are a number of factors that influence dry times in finishes. These are listed below:

- a) Amount of air movement and circulation over the drying surface
- b) Film thickness
- c) Relative Humidity
- d) Temperature

Amount of Air Circulation

This is considered the major contributing factor to dry time. Without air circulation, the solvent and water evaporating from the surface can quickly saturate a small layer of air just above the coating. If this saturated layer is not moved away from the surface, the rate of evaporation slows significantly. If the coating is in an enclosed room or space with limited air circulation, the dry rates will be significantly slower and there is a higher risk of marring the finish by walking on it or placing objects on it too soon. This is because solvents still in the coating will make it soft. A window that is open a crack will in a lot of circumstances not provide the type of circulation required. This is why having a fan to circulate the air is strongly recommended.

Film Thickness

This is a factor in drying of a coating because at the coating/ air interface, the solvent and water molecules nearest to the surface leave first due to their proximity to the surface. In other words, it dries from the top down. This forms a film that solvents in the coating

below must pass through. The curing process happens at a relatively slow rate so as this film builds and gets thicker, it becomes more and more difficult for the solvents to escape through each additional coat. The curing process becomes slower as the film becomes more solid. Thus the thicker films take longer to dry AND stay softer longer. Since the second coat is done over top of previous coat, it is significant that any solvents not dry on the first coat will have to travel twice as far through twice as much solid finish in order to escape. This means a number of things. Firstly, the “trapped” solvent takes a longer time to make its escape and secondly, the finish stays softer, longer because of this solvent presence and can easily be marred. Each time a new coat is applied over a coat that is not fully dried, the solvents passing up through will keep all the coats soft and easy to mar. Dry each coat well with air movement.

Relative Humidity

This affects dry time by changing the solvent carrying capacity of the air. The higher the humidity, the more water it contains. The

more water it contains, the less room that will be available at a

given temperature and barometric pressure, to pick up and carry away solvents from the finish. More airflow over the finish will help to compensate for this problem along with higher temperature.

Temperature

Temperature affects drying rate in two ways. First of all, it increases the air's capacity to carry vapor. This can increase the drying rate but only if the air is moving and circulating. Second, temperature can increase the rate of curing solvents, meaning that it can result in a faster drying time. But curing rates are a couple of orders of magnitude slower than the air transport and still can result in relatively slow dry times. This is also why opening a window a crack, particularly in the winter will not give satisfactory results. The

temperature declines thus slowing the curing rate but the airflow is still not good. The result can be a floor that dries slowly and remains in a softer state for a long period of time. It can be clearly seen from the above discussion that air movement and circulation is the most important factor in drying any floor finish. Other factors do have influence by they are only significant when used along with air circulation.

2.8 Column Test / Wicking Test

It is a very reliable test for measuring the scouring effect. A predetermined sample (18cm * 5cm sized) and standard dye solution (0.1% direct dye) is taken to perform the test. A mark is drawn at 1 cm above from the sample bottom. Then the sample is hung from a stick and immerses the sample in the dye solution up to 1cm mark. Hold the sample for 5 minutes in this position. The dye solution is absorbed by the sample and climb upward direction.

- Acceptable absorbing length is 30 – 50 mm.
- 30 mm absorbing length means the acceptable lower limit of scouring.
- 40 – 45 mm absorbing length means good/ very good scouring.
- 50 mm absorbing length means excellent scouring
- 18cm x 5 cm sample is cut from scoured sample
- In a beaker 1% direct dye red color is taken
- After that a marker is drawn at 1cm above from the sample bottom.
- Now the sample is hung from a wood stick supported by immersing that 1cm portion of fabric in the dye liquor
- Then we measured the point upto which the colored solution in absorbed straight above way by the sample in 5 min time.

Column Test Result:

Standard range 30-50 mm.

Expt. Sample Average range is 30 mm

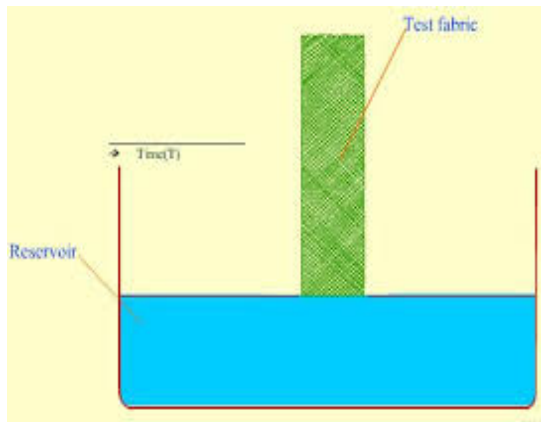

Fig: wicking test

Standard Test Method - 2

Wicking Test Methods Purpose:

To determine the wicking performance of fabric, the two tests listed below should be carried out and results reported.

1. Absorbency Test, AATCC Test Method

Requirement: 1.0 second or less.

2. Wicking Test, "Ciba"

Test Method Procedure: Follow below steps:

Apparatus - Glass Beaker (250 ml capacity), ruler, indelible pen, Stopwatch, Specimen holder, distilled water

3. Test must be conducted under standard conditions:

4. Specimen Preparation: Cut a total of four strips from each submitted sample as follows Cut two strips 15 cm x 2.5 cm with the long dimension being in the warp (wale) direction. Cut two strips 15 cm x 2.5 cm with long dimension being in the weft (course) direction. Mark each strip at 0.5 cm from one end of the long edge.

5. Testing Steps: Clamp the specimen at unmarked ends so that they hang vertically. Fill the beaker (container) with 100 ml of distilled water. Lower the strips into the beaker to the 0.5 cm mark and start timing. Remove specimen when 10 minutes is up.

Measure and record water travel length of the specimen. Average the results of the two tests in each direction. Report the results for warp and weft direction. Stop test if there is no water travel in five minutes.

Requirements: 5 cm or more after 10 minutes, Knit.

2.9 Water/moisture vapor transmission

Water/moisture vapor transmission is the rate at which water/moisture vapor diffuses through a fabric (Hatch, 1993). The moisture transport from the skin to the outer environments through clothing materials, often referred to breathability of the fabric, is an important factor in human comfort (Tortora & Collier, 1997; Weiner, 1970; Whelan, MacHattie, Goodings, & Turl, 1955).

The transfer of water/moisture vapor is usually from the wetter environment to the dryer environment until equilibrium is reached (Collier & Epps, 1999). The body produces moisture in the form of perspiration, which includes sensible perspiration and insensible perspiration. Sensible perspiration is produced as liquid perspiration under hot or strenuous conditions. Insensible perspiration evaporates within the skin layers in the form of emitting water/moisture vapor. A significant amount of perspiration should leave by vapor diffusion through the fabric components of the garment to maintain heat balance (Weiner, 1970). As moisture is evaporated from the skin surface, a moisture-vapor-permeable fabric allows moisture vapor to go through, keeping the fabric and skin dry and permitting evaporative cooling (Hatch, 1993). Hygroscopic 20 fabrics have the capability to absorb water vapor when they are surrounded by humid air and release water vapor in dry air (Barnes & Holcombe, 1996). A garment for daily use should have a degree of water/moisture vapor transmission, in which the hotter the environment or the greater the activity level, the higher the water/moisture vapor transmission is required (Weiner, 1970; Whelan, et al., 1955). For example, when people do exercise in a hot environment, the function of perspiration as a factor in body-temperature regulation will be most effectively achieved if insensible evaporation can take place immediately. If people wear clothing with a low water/moisture vapor transmission property under hot situations, the heat transfer from people's skin outward will be suppressed or reduced, and thus, people may feel uncomfortable. However, for some products, fabrics with low water/moisture vapor transmission capability are required (e.g., chemical protective clothing, raincoats, diapers, tents, tarpaulins, and apparel) (Wehner, Miller, & Rebenfeld,

1988). In these products, a vapor barrier is needed to achieve the performance of their end-use.

2.9.1 Water Vapor Transmission

Water vapor transmission is a measure of how much water vapor will pass through a material per unit area per unit time. Testing is performed by sealing a specimen to the open mouth of a test dish containing either desiccant or water and placing the assembly into a controlled atmosphere. The test unit is weighed periodically and the weight is plotted as a function of time. Water vapor transmission is taken as the slope of the curve (in the linear region) divided by the area of the dish opening.

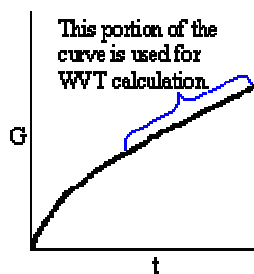

Water Vapor Transmission is calculated using the formula:

$$WVT = G / t / A = (G / t) / A$$

where G is the weight gain, t is the time tested, and A is the area of the test area (area of dish opening).

2.9.2 Factors that influence water/moisture vapor transmission

Fiber content and fabric geometry are two main factors that may affect the water/moisture vapor transmission of textiles. Fiber content is one of the determinants of water/moisture vapor transmission because water/moisture vapor is absorbed by fibers, transported through fibers, and then desorbed to the environment (Tortora & Collier, 1997). In this process, the inherent absorbency of the fibers or their affinity for water will determine the process of water/moisture vapor transmission. For example, rayon and wool absorb moisture readily from the body, but polyester and olefin do not. Whelan, et al. (1955) studied the influence of fiber composition on the resistance to water/moisture vapor transmission. The researchers used a wide range of textile materials including wool, cotton, silk, acetate, nylon, and viscose rayon with different fabric structures, 21 such as

thickness, weight, and density. The results showed that different types of fibers had different influences on water/moisture vapor transmission because they had different moisture absorption characteristics. Lower resistance to water/moisture vapor transmission was exhibited in more hygroscopic fabrics. As the moisture-absorption capacity decreased, the resistance to water transfer increased. Fabrics with different wicking characteristics may also have different influences on water/moisture vapor transmission. Olefin fabrics are excellent in wicking, and therefore, often used in sportswear. Although olefin fabrics do not absorb water, they permit liquid perspiration to wick through the yarns very efficiently and provide high water/moisture vapor transmission as well. Whelan, et al. (1955) found that the spatial/geometric distribution of fibers in a fabric might also play a significant role in water/moisture vapor transmission properties. The changes of thickness and percentage fiber volume would affect the resistance to water/moisture vapor transmission of any particular cloth. As the fabric's thickness and percentage fiber volume increased, the resistance of the fabric to water/moisture vapor transmission increased. Yoon and Buckley (1984) tested the water/moisture vapor transmission rate (WVTR) for plain jersey knit fabrics of 100% polyester, 80/20, 65/35, and 50/50 polyester/cotton blends, and 100% cotton. The results showed that 100% polyester fabric exhibited a substantially higher WVTR value than the 100% cotton fabric, and the WVTR value for polyester/cotton blends fell between the WVTR values of the two pure fabrics, responding to their blend level. The researchers explained that the reason for variation of WVTR values with different fiber contents lay in the effect of fiber type on fabric geometry. Instead of the physical properties of the fiber, such as absorbency and wicking, the difference in fiber geometry brought about difference in fabric geometry. For example, the water/moisture vapor transmission property of a fabric is basically a property of 22 inter-yarn pore air, which is affected by inter-yarn pore size and thickness of the fabric. The fabric geometric parameters of porosity and thickness are affected by yarn diameter, which is determined by the fiber composition.

2.9.3 Measurement of water/moisture vapor transmission

Gibson (1993) discussed two common methods that were applied to measure water/moisture vapor transmission of clothing materials: cup/dish tests (i.e., the ASTM test method of E96-80) and sweating guarded hot plate devices (i.e., the ASTM test method of D1518-77). The cup/dish methods are easy to carry out and inexpensive

equipment is used. People usually prefer the sweating hot plate method, which simulates the heat and mass transfer conditions of the human body very accurately, although the hot plate method needs much more elaborate equipment and much larger sample sizes. In the ASTM E96–80 water method, the WVTR is determined by measuring the grams of water/moisture transmitted per square meter of specimen in a 24 or 48-hour period. The reported quantity in $\text{g/m}^2/\text{hour}$ was acquired by periodically weighing the sample dish. The water method of ASTM E96-80 has its inherent problems. The still air layer in the cup between the fabric sample and the water surface may have a higher resistance to water/moisture vapor transmission than the fabric sample itself (Gibson, 1993). Because of this limitation, the ASTM E96-80 method is only appropriate for evaluating water/moisture vapor transmission of fabrics with high water vapor resistances. However, the ASTM E96-80 method of the cup/dish test is used continuously because of its wide acceptability, convenience, and large existing database of previous research results. The sweating guarded hot plate method comes from the ASTM D 1518-77, Standard Test Method for Thermal Transmittance of Textile Materials between Guarded Hot Plate and Cool Atmosphere. The plate measures the required power to keep a flat isothermal area at a constant temperature. There are two effects in the test. First, when the plate is covered with a test fabric, the amount of required power to keep a flat isothermal area at a given temperature is related to the dry thermal resistance of the test sample. Second, if the plate is saturated with water, the amount of required power to keep it at a given temperature is related to the WVTR at which water evaporates from the surface of the plate and diffuses through the test material. Because the sweating guarded hot plate methods account for both heat and vapor transfer effects, the dry thermal resistance of the test material needs to be tested first and then water/moisture vapor transmission properties of the test fabric is determined by saturating the plate surface with water and repeating the test. Gibson (1993) used a variety of materials to study whether there was an experimental correlation between the two kinds of water/moisture vapor transmission tests (i.e., cup/dish test and sweating guarded hot plate test).

2.9.4 The researcher used a full range of testing materials grouped by four classes

- (a) Permeable materials (i.e., woven and non-woven fabrics),
- (b) Hydrophilic membrane laminates, which were made with a monolithic hydrophilic polymer coating or layer,

(c) Hydrophobic membrane laminates, which were made from a hydrophobic polymer that contained tiny interconnected pores to allow water/moisture vapor to diffuse through the membrane, and

(d) Impermeable materials.

membrane laminates exhibited no correlation between the two test methods. The hydrophilic materials showed much better water/moisture vapor transmission properties in the sweating guarded hot plate test than they did in the cup/dish test. The lower resistance to water/moisture vapor transmission in the sweating guarded hot plate tests was due to much greater water concentration in the hydrophilic polymer layer. The researcher found that for the permeable materials and hydrophobic membrane laminates, a linear correlation existed between the two test methods. However, the hydrophilic

The researcher concluded that the ASTM E96-80 method was adequate for measuring most materials that experienced water/moisture vapor diffusion through the air spaces in their inner structures. Another test method, which is called Desiccant Method in ASTM E 96-00, is also used for measuring water/moisture vapor transmission. In a controlled atmosphere (a recommended temperature of 32°C and relative humidity of 50%), a test material is sealed to the open mouth of a dish containing a desiccant with known weight, which is able to absorb water/moisture vapor from the air. The periodic weightings of the assembled test dishes determine the rate of water/moisture vapor transmission through the specimen into the desiccant.

Testing Methods

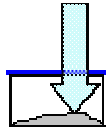
Method	Summary	Diagram
Desiccant	The test specimen is sealed to the open mouth of a test dish containing a desiccant and the assembly placed in a controlled atmosphere. Periodic weightings determine the rate of water vapor movement through the specimen from the controlled atmosphere into the desiccant.	

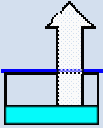
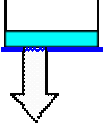
Water	The test specimen is sealed to the open mouth of a test dish containing water and the assembly placed in a controlled atmosphere. Periodic weighings determine the rate of water vapor movement through the specimen from the water to the controlled atmosphere.	
Inverted Water	Same as the water method except that the test dish is turned upside-down so the water is in contact with the specimen.	

CHAPTER 04
MATERIALS AND METHODS

3.1 Materials

3.1.1 Fabric

The grey cotton fabric was used in our experiment. The specification of the fabric is listed in Table 3.1.

Table 3.1 Specifications of the fabric

Parameters	Grey fabric
Fiber content	100% cotton
Structure	Single jersey
Yarn Count (Ne)	30

3.1.2 Dyes

Cold brand reactive dye was used in our experiment. The name of the dyes is- Procion Blue.

3.1.3 Chemicals

The chemicals used in the experiment are listed below table no 3.2.

Table 3.2 List of chemicals

Chemicals	Function
NaCl	To increase the dye affinity to fiber
NaOH	To create the optimum ph in dye bath
Soda Ash	As fixing agent
Wetting agent	It contirbutes to dye heavier or lighter
Sequestering agent	Its removes the hardness of water

Hydrogen Peroxide	For bleaching
Stabilizer	Complexes heavy metal ions and thus prevents catalytic damage & Is non-foaming
Cationic Softener (Texamina C)	For softening the fabrics
Nonionic Softener (Texamina N)	For softening the fabrics
Polyethylene emulsion (Nanofinish PES)	For softening the fabrics & make Comfortable

3.1.4 Equipments

The equipments used in our experiment is listed below table 3.3.

Table 3.3 Name of equipment

Equipment	Features
Beaker	For balance the Chemicals accurately
Dye bath	Scouring bleaching & Dyeing
Thermometer	To check the temperature
Gas Burner	To make the Temperature & heat source for dyeing.

3.1.5 Machines

The specifications of machines used in the experiment are given in below table no 3.4

Table 3.4 Specification of machine

Name of m/c	Specification
--------------------	----------------------

Weight balance	Model No: TW 212, Year of Manufacturer: 2009 Origin: Taiwan, Function: Accurate weight balance.
Dryer	Model No:417 Accudry ² ,Manufacturer: James H. Heal, Origin: England, Function: Drying.

3.2 Methods

3.2.1 Methods of scouring-bleaching: At first we took 175gm grey cotton knitted fabric.

We took a bath and made chemical solution for scouring bleaching by following recipe. We used a gas burner for heating the bath. We increased the temperature per 1 min in 2⁰C. and highest temperature increased 95⁰C and and stayed 1 hour for scouring bleaching. After 1 hour we stopped process, and fabric are washed by normal water and squeezing and dried.

Recipe for scouring-bleaching in single stage:

- | | | |
|--|---|--------------------------------------|
| 1. Wetting agent | = | 0.5 g/L (1% stock sol _n) |
| 2. Sequestering agent | = | 0.5g/ L (1% stock sol _n) |
| 3. N _a OH | = | 4 g/L (2% stock sol _n) |
| 4. Peroxide (H ₂ O ₂) | = | 2.5g/L (2% stock sol _n) |
| 5. Stabilizer | = | 0.5g/l |

Condition:

- | | | |
|-------------------|---|-------------------|
| 1. M:L | = | 1:30 |
| 2. P ^H | = | 10-12 |
| 3. Time | = | 1 Hour |
| 4. Temperature | = | 98 ⁰ C |
| 5. Sample weight | = | 175gm |

Calculation:

$$\text{Total Liquids} = 175 \times 30$$

$$= 5250 \text{ ml}$$

$$\text{Wetting agent} = 0.5 \times 5250 \times 100 / 1000 \times 1$$

$$= 262.5 \text{ ml}$$

$$\text{Sequestering agent} = 0.5 \times 5250 \times 100 / 1000 \times 1$$

$$= 262.5 \text{ ml}$$

$$\text{NaOH} = 4 \times 5250 \times 100 / 1000 \times 2$$

$$= 1050 \text{ ml}$$

$$\text{Peroxide} = 2.5 \times 5250 \times 100 / 1000 \times 2$$

$$= 656.25 \text{ ml}$$

$$\text{Stabilizer} = 0.5 \times 5250 \times 100 / 1000$$

$$= 262.5 \text{ ml}$$

$$\text{Total water} = 5250 - (262.5 + 262.5 + 1050 + 656.25 + 262.5)$$

$$= 2756.25 \text{ ml}$$

3.2.2 Methods of Dyeing: After scoured and Bleached the samples are ready for dyed. First we took a dye bath and made dye solution by following recipe. A gas we used for heat source, we increased the temperature per 1 min in 2⁰C, and highest temperature increased 60⁰C and and stayed 30 min. After 30 min we stopped dyeing and we washed the fabric by water.

Recipe for Dyeing:

1. Reactive Dye (cold brand) = 1% owf

- | | |
|-----------------------------|--|
| 2. NaCl | = 40g/L |
| 3. Na_2CO_3 | = 5g/L |
| 4. NaOH | = 0.3g/L (for maintaining P^{H} 10.5-11) |
| 5. Fabric weight | = 170 gm |
| 6. M: L | = 1:30 |
| 7. Temperature | =60°C |

Calculation:

$$\text{Total Liquor} = 170 \times 30$$

$$= 5100 \text{ ml}$$

$$\text{Dye} = 1 \times 5100 \times 100 / 1000$$

$$= 510 \text{ ml}$$

$$\text{NaOH} = 0.3 \times 5100 \times 100 / 1000$$

$$= 153 \text{ ml}$$

$$\text{NaCl} = 40 \times 5100 / 1000$$

$$= 204 \text{ ml}$$

$$\text{Na}_2\text{CO}_3 = 5 \times 5100 / 1000$$

$$= 25.5$$

$$\text{Total water} = 5100 - (510 + 153 + 204 + 25.5)$$

$$= 4207.5 \text{ ml}$$

3.2.3 Application method of softener: Completed dyeing we made softener solution by following recipe. We used three different softeners & took four concentration from softeners. We used 1% acetic acid for neutral the softener solution and treated each sample 15 minutes.

Recipe for Softener Treatment:

- 1) Softener..... 0.25%, 0.50%, 1%, 1.5% owf (Stock Solⁿ.....1%)
- 2) Acetic Acid..... 0.1 g/l (Stock Solⁿ..... 1%)
- 3) Time..... 15 min
- 4) M: L..... 1:20
- 5) Sample weight..... 10 mg
- 6) P^H..... Neutral
- 7) Temperature..... Room

Calculation:

$$\begin{aligned} 1) \text{ Softener (0.25\%)} &= 10 \times 0.25 \times 1\% / 1\% \\ &= 2.5 \text{ ml} \end{aligned}$$

$$\begin{aligned} 2) \text{ Softener (0.50\%)} &= 10 \times 0.5 \times 1\% / 1\% \\ &= 5 \text{ ml} \end{aligned}$$

$$\begin{aligned} 3) \text{ Softener (1\%)} &= 10 \times 1 \times 1\% / 1\% \\ &= 10 \text{ ml} \end{aligned}$$

$$\begin{aligned} 4) \text{ Softener (1.5\%)} &= 10 \times 1.5 \times 1\% / 1\% \\ &= 15 \text{ ml} \end{aligned}$$

$$\begin{aligned} 5) \text{ Acetic Acid} &= 0.1 \times 100 \times 100 / 1000 \\ &= 1 \text{ ml} \end{aligned}$$

$$\begin{aligned} \text{Total water for (0.25\%)} &= 100 - (2.5 + 1) \text{ ml} \\ &= 96.5 \text{ ml} \end{aligned}$$

$$\begin{aligned} \text{Total water for (0.50\%)} &= 100 - (5 + 1) \text{ ml} \\ &= 94 \text{ ml} \end{aligned}$$

$$\begin{aligned} \text{Total water for (1\%)} &= 100 - (10 + 1) \text{ ml} \\ &= 89 \text{ ml} \end{aligned}$$

$$\begin{aligned} \text{Total water for (1.5\%)} &= 100 - (15 + 1) \text{ ml} \\ &= 84 \text{ ml} \end{aligned}$$

3.2.4 Methods of determining moisture regain and moisture content: First we took the Dry weight of all samples, and after drying we applied curing machine for oven dry weight of all samples. Then we apply following formula

$$\text{Moisture Regain (R\%)} = 100W/D$$

$$\text{Moisture Content (C\%)} = 100W/(D+W)$$

Where, Oven dry weight = D

And Weight of water = W (Original weight-Oven dry weight)

The results found are given in the table 3.5

Table 3.5: Moisture regain and moisture content of fabric samples

Softener	Concentration % owf	Normal Weight N (gm)	Dry weight D (gm)	Moisture regain %	Moisture Content %
Softener untreated		5	4.52	10.62%	9.60%
Non ionic Softener	0.25	5	4.51	10.86%	9.80%
	0.5	5	4.50	11.11%	10.00%
	1.0	5	4.50	11.11%	10.00%
	1.5	5	4.50	11.11%	10.00%
Cationic Softener	0.25	5	4.71	6.15%	5.80%
	0.5	5	4.71	6.15%	5.80%
	1.0	5	4.72	5.93%	5.60%
	1.5	5	4.73	5.70%	5.40%
PES	0.25	5	4.52	10.62%	9.60%

	0.5	5	4.52	10.62%	9.60%
	1.0	5	4.52	10.62%	9.60%
	1.5	5	4.51	10.86%	9.80%

3.2.5 Methods of determining drying time: At first we wet the samples of fabrics, and after squeezing we took weight of samples. After weight we enter drying machine at 60°C, then after per 2 min we checked the sample, for which sample was first dry.

Table 3.6

Softener	Concentration% owf	Normal weight N (gm)	Weight of fiber after wash and squeeze (gm)	Time taken to dry To 5 gm Hr-min
Softener untreated		5	11.50	20 min
Non ionic softener	0.25	5	11.50	22 min
	0.5	5	11.50	24 min
	1.0	5	11.50	24 min
	1.5	5	11.50	24 min
Cationic softener	0.25	5	11.50	18 min
	0.5	5	11.50	18 min
	1.0	5	11.50	16 min
	1.5	5	11.50	16 min

PES	0.25	5	11.50	26 min
	0.5	5	11.50	26 min
	1.0	5	11.50	26 min
	1.5	5	11.50	28 min

3.2.6 Methods of determining wicking: 13cm x 1 cm sample is cut from scoured sample

In a beaker 1% direct dye red color is taken from all softener treated fabrics.

After that a marker is drawn at 1cm above from the sample bottom.

Now the sample is hung from a wood stick supported by immersing that 1cm portion of fabric in the dye liquor. Then we measured the point up to which the colored solution in absorbed straight above way by the sample in 1 min time. After 1 min we got the following result.

Table 3.7 Wicking Test results

Softener	Concentration% owf	Initial weight of fabric M (gm)	Weight after test M ₂ (gm)	Length of absorbed portion (mm)	Time (min) fixed
Softener untreated				3	1
Non ionic softener	0.25	0.29	0.32	4	1
	0.5	0.26	0.28	3	1
	1.0	0.28	0.30	3	1
	1.5	0.25	0.29	3	1
Cationic softener	0.25	0.28	0.34	2	1
	0.5	0.30	0.36	2	1

	1.0	0.27	0.30	2	1
	1.5	0.27	0.32	2	1
Nanofinish PES	0.25	0.28	0.33	3	1
	0.5	0.28	0.30	3	1
	1.0	0.26	0.32	4	1
	1.5	0.27	0.34	4	1

3.2.7 Water vapor transmission

Water vapor transmission through the fabric sample was measured by following ASTM E96 method. According to this method....

The calculation was done by the following formula-

$$WVT = m / (T \times A)$$

Where, m = Weight transferred (gram)

T = time (hour)

A = area of the cup (m^2)

Area of the glasses was found $0.0032 m^2$

Table 3.8 Weight obtained in different time intervals

Softeners	Concentration% owf	Initial weight of dish with water and fabric W (gm)	Weight after 2 hour W_1 (gm)	Weight after 4 hour W_2 (gm)	Weight after 6 hour W_3 (gm)	Weight after 8 hour W_4 (gm)

Softener untreated		177.23	176.85	175.84	174.05	171.73
Non ionic softener	0.25	178.90	178.21	177.05	175.2	173.1
	0.5	177.50	177.13	176.24	174.98	172.46
	1.0	179.23	179.00	178.22	176.21	173.19
	1.5	178.30	178.11	177.07	175.91	172.82
Cationic softener	0.25	179.59	179.35	178.33	177.07	174.55
	0.5	181.42	180.50	179.80	178.18	175.79
	1.0	178.36	178.21	177.70	177.04	175.72
	1.5	179.23	179.13	178.79	178.35	177.47
PES	0.25	186.13	186.09	185.88	185.63	185.13
	0.5	187.20	187.06	186.61	186.02	184.84
	1.0	186.15	186.07	185.73	185.26	184.37
	1.5	185.25	185.09	184.69	184.13	183.01

Table 3.8 WVT in different time intervals

Softeners	Concentration% owf	WVT in first 2 hours gm/h-m ²	WVT in second 2 hours gm/h-m ²	WVT in third 2 hours gm/h-m ²	WVT in fourth 2 hours gm/h-m ²
Softener untreated		59.38	157.81	279.69	362.5
Non ionic softener	0.25	107.81	181.25	289.06	328.13
	0.5	57.81	139.06	196.88	393.75
	1.0	35.94	121.88	314.06	471.88
	1.5	29.69	162.5	181.25	482.81
Cationic softener	0.25	37.5	159.38	196.88	393.75
	0.5	143.75	109.38	253.12	373.44
	1.0	23.44	79.69	103.13	206.25
	1.5	15.63	53.13	68.75	137.5
Nanofinish PES	0.25	6.25	32.81	39.06	78.125
	0.5	21.88	70.31	92.18	184.38
	1.0	12.5	53.13	73.44	139.06
	1.5	25	62.5	87.5	175

SAMPLE ATTACHMENT

Non ionic softener		Cat ionic softener		Polyethylene emulsion softner	
0.25% owf		0.25% owf		0.25% owf	
0.50% owf		0.50% owf		0.50% owf	
1.00% owf		1.00% owf		1.00% owf	
1.50% owf		1.50% owf		1.50% owf	
Softener untreated					

CHAPTER 05
RESULTS AND DISCUSSIONS

4.1 Effect of softener on moisture regain and moisture content

Effect of different softeners on moisture regain and moisture content is shown in figure 4.1. We can see that moisture regain and moisture content in polyethylene softener, non ionic softener, softener untreated is high than cat ionic softener. It means poly ethylene softener, non ionic softener teated fabric is more comfortable than cat ionic softener teated fabric.

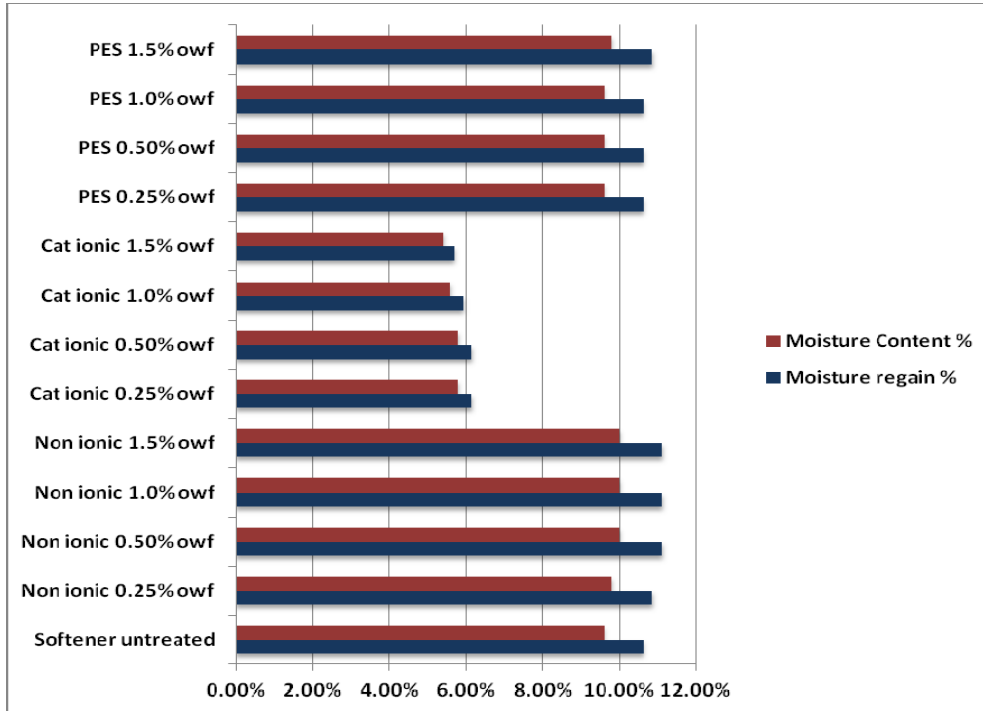

Figure 4.1: Effect of softener on moisture regain and moisture content

4.2 Effect of softener on drying time

Effect of different softener on drying time is shown in figure 4.2. As Polyethylene emulsion softner, non ionic softener, softener untreated is much better moisture regain and moisture content so it must be take to much time to be drying. Here we can see that after increasing percentage of the softener it take to much time to dry. Cat ionic is less moisture regain and moisture content so it needs less time to be drying.

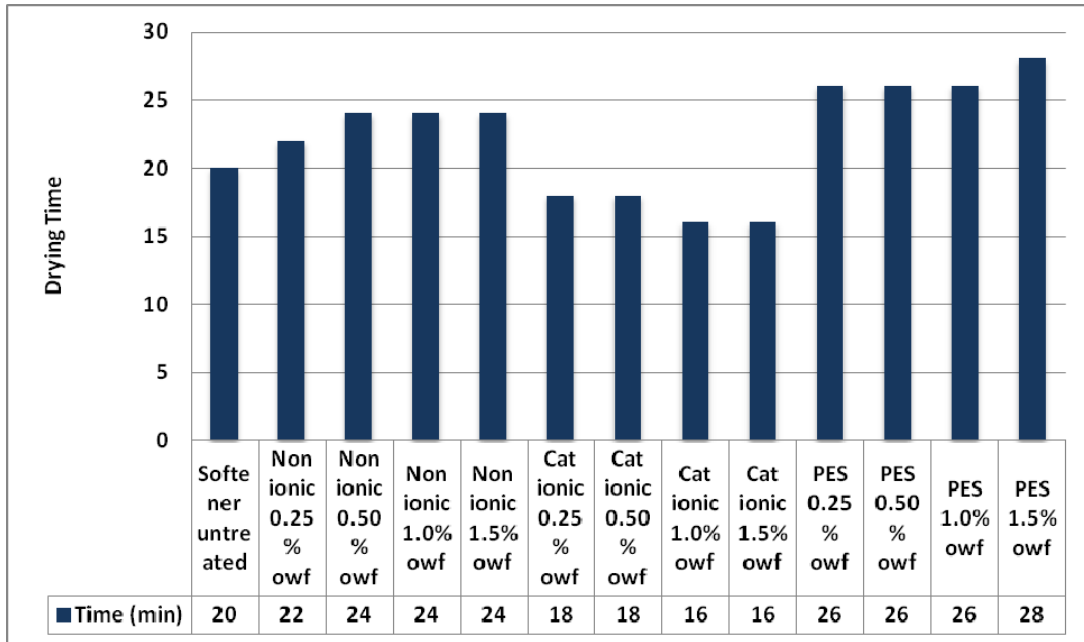

Figure 4.2: Effect of softener on drying time

4.3 Effect of softener on wicking properties

Effect of different softener on wicking properties is shown in figure 4.3. We can see the Cationic softener absorbed low rate of color, but Nonionic and PES softener absorbed moderate and high rate of colour. After cationic softener treated the fabric absorbed very low rate colour.

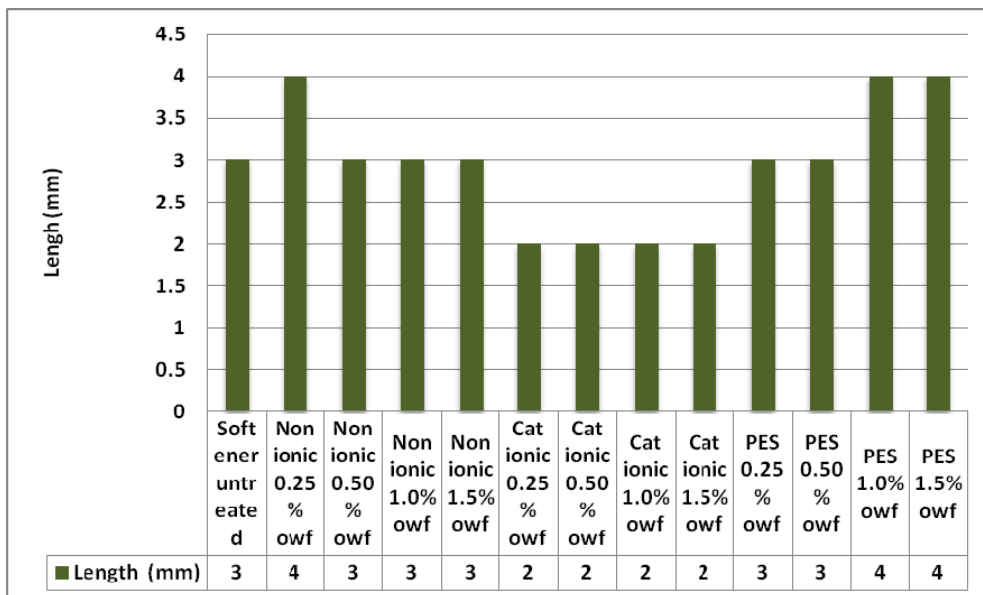

Figure 4.3: Effect of softener on wicking properties

4.4 Effect of softener on water vapor transmission

Effect of different softener on water vapor transmission is shown in figure 4.4. We can see that non ionic softener after increasing percentage and time it does much water vapor transmission than other softener. We also notice that polyethylene emulsion softener after increasing percentage and time it does less water vapor transmission .

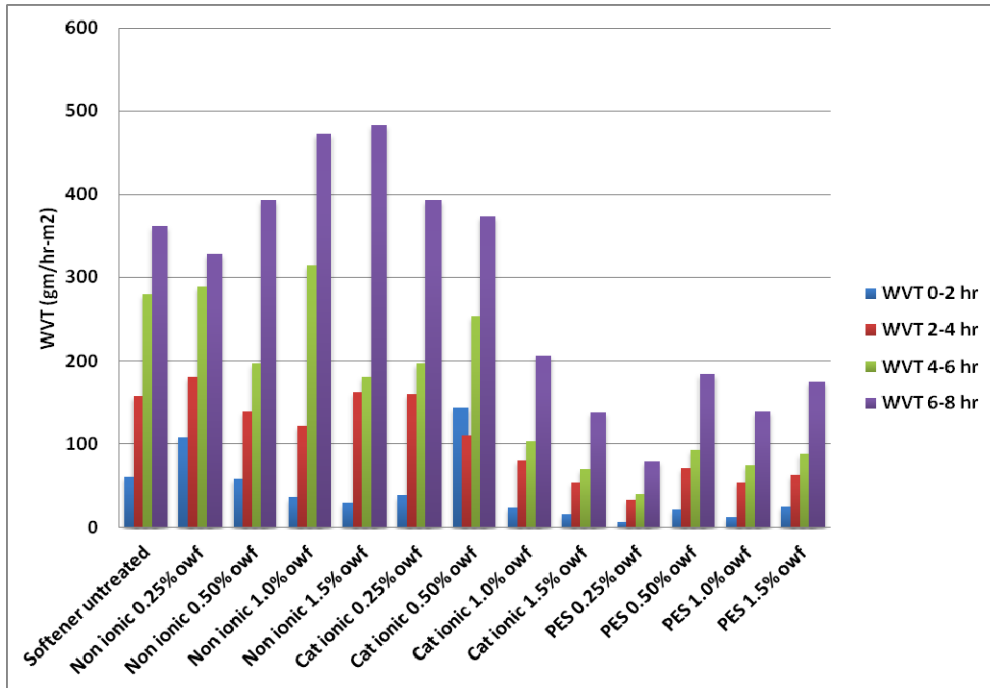

Figure 4.4: Effect of softener on water vapor transmission

CHAPTER 06
CONCLUSION

It is the ending part of your project report which will summarize the precise results and provide the research outcomes. You must not elaborate this part and the length of contents should not exceed one page. We can see that moisture regain and moisture content in polyethylene softener, non ionic softener, softener untreated is high than cationic softener. It means polyethylene softener, non ionic softener treated fabric is more comfortable than cationic softener treated fabric. Polyethylene emulsion softener, non ionic softener, softener untreated is much better moisture regain and moisture content so it must be taken to much time to be drying. Here we can see that after increasing percentage of the softener it takes to much time to dry. Cationic is less moisture regain and moisture content so it needs less time to be drying. Cationic softener absorbed low rate of color, but Nonionic and PES softener absorbed moderate and high rate of colour. After cationic softener treated the fabric absorbed very low rate colour.

water vapor transmission rate increases with time for all types of softener application but the rate was far lower for the polyethylene emulsion than the others. Moreover, transmission rate increases with the

REFERENCES

- [1] Shenai, A. V., (1993), Technology of Textile Processing Volume II: Chemistry of Dyes and Principles of Dyeing, *Sevak Publications*.
- [2] Shubhashish Das, V. K. Kothari (2012), Moisture vapour transmission behavior of cotton fabrics, *Indian Journal of Fiber and Textile Research*, 37, 151-156.
- [3] [http://nopr.niscair.res.in/bitstream/123456789/14265/1/IJFTR%2037\(2\)%20151-156.pdf](http://nopr.niscair.res.in/bitstream/123456789/14265/1/IJFTR%2037(2)%20151-156.pdf) (Retrieved date: 29th May 2015).
- [4] <http://www.fibtex.lodz.pl/2011/3/69.pdf> (Retrieved date: 31th May 2015)
- [5] <http://nptel.ac.in/courses/116102029/58> (Retrieved date: 30th April 2015)
- [6] http://www.google.com/imgres?imgurl=http://product-industries-research.hktdc.com/resources/MI_Portal/Article/psls/2011/12/362310/1324610991651_2_362310.jpg&imgrefurl=http://product-industries-research.hktdc.com/business-news/article/Garments-Textiles/New-AATCC-Test-Methods-for-Wicking-and-Moisture-Management-Properties/psls/en/1/1X000000/1X07RK66.htm&h=439&w=684&tbnid=P3Xuh0FBJsi3eM:&zoom=1&docid=QSZEwUAKUW8VrM&hl=en&ei=x4_5VN2RLZC3uQTxr4KIDw&tbm=isch (Retrieved date: 30th May 2015)