

Design and construction of a smart switching device using Microcontroller

This report presented in partial fulfillment of the requirements for the degree of Bachelor of Science in Electrical and Electronic Engineering.

Submitted BY

Md.Ismile Bakth Ansary

ID:111-33-427

Department of EEE

Daffodil International University

Supervised BY

Professor Dr. Md. Fayzur Rahman

Professor and Head

Department of EEE

Daffodil International University



**Daffodil International University
Dhaka, Bangladesh**

April, 2015

APPROVAL

This project titled “**Design and construction of a smart switching device using Microcontroller**”, submitted by Md.Ismile Bakth Ansary to the Department of Electrical and Electronic Engineering, Daffodil International University, has been accepted as satisfactory for the partial fulfillment of the requirements for the degree of B.Sc. in Electrical and Electronics Engineering and approved as to its style and contents. The presentation has been held on.

BOARD OF EXAMINERS

Professor Dr. M. Shamaul Alam
Professor and Dean
Department of EEE
Faculty of Science & Information Technology

Dr. Md. Fayzur Rahman
Professor and Head
Department of EEE
Daffodil International University

DECLARATION

We hereby declare that, this project has been done by us under the supervision of **Professor Dr. Md. Fayzur Rahman, Professor and Head, Department of EEE** Daffodil International University. We also declare that neither this project nor any part of this thesis has been submitted elsewhere for award of any degree or diploma.

Supervised by:

Dr. Md. Fayzur Rahman
Professor and Head
Department of EEE
Daffodil International University

Submitted by:

Md. Ismile Bakth Ansary
ID: 111-33-427
Department of EEE
Daffodil International University

ACKNOWLEDGEMENT

First I express my heartiest thanks and gratefulness to almighty Allah for his divine blessing makes me possible to complete this project successfully.

I feel grateful to my **Supervisor Dr. Md. Fayzur Rahman, Professor and Head**, Department of EEE Daffodil International University, Dhaka. Deep knowledge & keen interest of my supervisor in the field of Electronics influenced us to carry out this project. His endless patience, scholarly guidance, continual encouragement, constant and energetic supervision, constructive criticism, valuable advice at all stage made it possible to complete this thesis.

I would like to thank my entire course mate in Daffodil International University, who took part in this discuss while completing the course work.

I would like to express my heartiest gratitude to the Dean, Faculty of Engineering, for his kind help to finish my project and also to other faculty member and the staff of EEE department of Daffodil International University.

Finally, I must acknowledge with due respect the constant support and patients of my parents as well as my family members.

_____*Authors*

Abstract

Automatic control of home appliances is highly demanding now a day .In this works we have designed and constructed a circuit which especially meet the requirement of control the home appliances through any remote control device that is portable within the periphery of the room. The device is able to control a load of high power rating from remote area. The system works satisfactorily and it is also considered to be a cost effective system. This device will make our life become easier. We can easily control three devices like 2 lights, 1 fan from the distance of 11 meter by remote control. We don't need to go near the switch board then turn the switch on. We can control them easily by remote from 11 meter distance. The most special feature is we can control the speed of fan for nine times. In case of remote failure we can use it as like as normal switching device. I think one day it will be the most attractive feature of our digitalized life.

KEYWORDS: Microcontroller, home appliances, automatic control, cheap installation cost.

TABLE OF CONTENT

Content No:	Page No
Approval	i
Acknowledgement	ii
Declaration	iii
Abstract	iv
Chapter 1- Introduction	
1.1 Introduction	1
1.2 Literature Review	1
Chapter 2-Circuit Description	
2.1 Block Diagram	2
2.2 Component	2
2.3 Outlook View	3
2.4 Working Principle	3
Chapter 3- Microcontroller	
3.1 Introduction	4
3.2History	5
3.3Data Sheet	6
Chapter 4- Capacitor	
4.1 Ceramic capacitor	
4.1.1 Introduction	7
4.1.2 History	8
4.1.3 Classes and application	10
4.2 Film capacitor	
4.2.1Introduction	11
4.2.2 Overview of construction and features	12
4.3 Electrolytic capacitor	
4.3.1Introduction	14
4.3.2Basic Information	15
4.3.3Charge Principle	15

Chapter 5- TRAIC	
5.1 Introduction	16
5.2 Physical operation	17
Chapter 6- Zener Diode	
6.1 Introduction	18
6.2 Operation	19
6.3 Construction	20
Chapter 7- Momentary Switch	
7.1 Introduction	21
7.2 Working principle and application	22
7.3 Advantage	22
Chapter 8- IR Sensor	
8.1 Introduction	23
8.2 Working principle	24
Chapter 9- LED	
9.1 Introduction	25
9.2 History	26
Chapter 10- Resistor	
10.1 Introduction	27
Chapter 10- Cost Analysis	28
Conclusion	29
Reference	30

1.1 Introduction

With the advancement in technology, new electrical protective devices with various levels of complexity have been designed, and different failures from these systems have been recorded. The design and construction of a reliable cost effective protective device, “the remotely controlled power supply switching unit” is to be used in collaboration with some other forms of protective devices (circuit’s breakers and fuses). The primary aim of this work is to design a simple cost effective and reliable circuit (protective system), which will aid in-protecting electrical and electronic devices in our homes and offices with ease.

Basically, a remote control operates in the following manner. A button is pressed; this completes a specific connection, which produces a Morse code line signal specific to that button. The transistors amplify the signal and send them to the LED, which translates the signal into infrared light. The sensor on the appliance detects the infrared light and response appropriately to the received signal or command .

The aim of this work is to facilitate the protection of electrical and electronic devices from electrical faults in the home, and also to facilitate the control of mains supply to a room from a distance easily. The infrared remote control is made up of a transmitter and a receiver (Photo detector). The transmitter transmits within the frequencies of 30 KHz and 60 KHz having a wavelength of about 950nm.

Today, remote control is a standard feature on some consumer electronic products including VCRs, cable and satellite boxes, digital videodisc players and home audio receivers. The most sophisticated TV sets have remotes with as many as 50 buttons. In year 2000, more than 99 percent of all TV sets and 100 percent of all VCRs and DVD players sold in the United States were equipped with remote control. The average individual these days probably picks up a remote control at least once or twice in an hour. And in most pieces of consumer electronics from recorder to stereo equipment, an infrared remote control is usually always included

1.2 Literature Review

The circuit drawn pertains to regular industrial the project. This shows how to control a device using remote controlled switch. We mainly use microcontroller, IR sensor to complete this project.

2.1 Block diagram

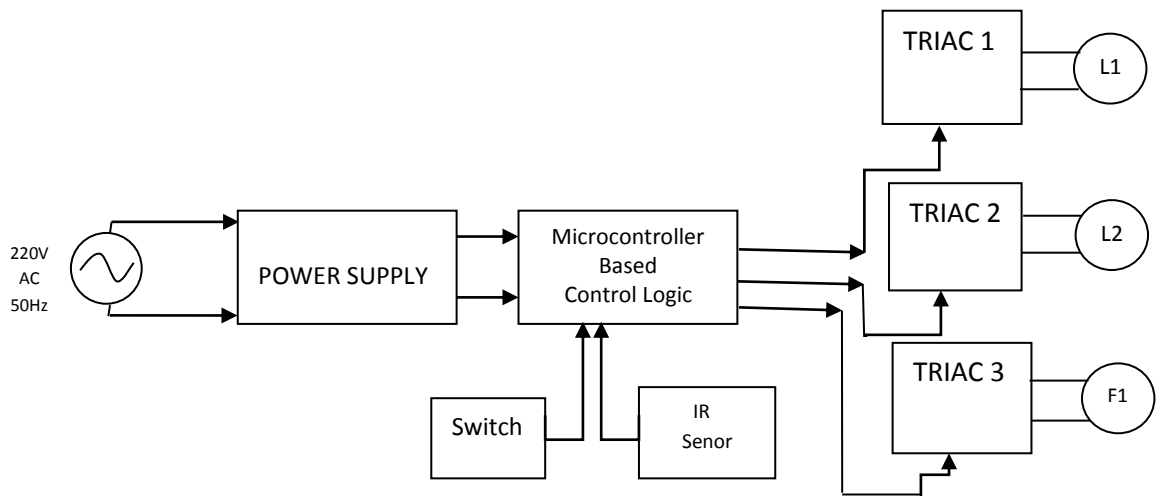
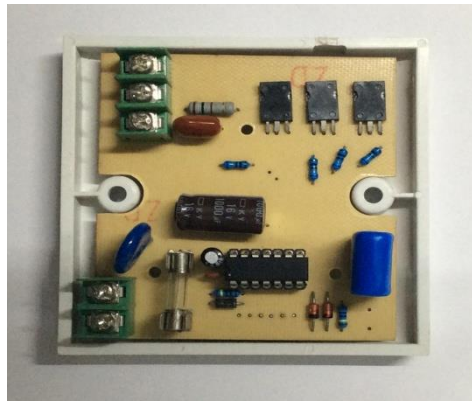

Fig: 1.1 Block Diagram

2.2 Component

Name	Device Type	Quantity
PIC16F676	Main Microcontroller	1
0.1uf 50V Cap	Ceramic capacitor	2
1.0uf 630V cap	Film capacitor	1
0.01uf 450V Cap	Film capacitor	3
BT136 TRIAC	AC Switching TRIAC	3
5.6V 1W Zener Diode	Zener Diode	2
1N4007 1A Diode	Rectifier Diode	2
330uf 16V cap	Electrolytic capacitor	2
100R 1W	1W Resistor	3
Buttons	Momentary switch	4
IR Sensor	Infra Red Sensor	1
LED	Green Indicator LED	1
680R 1/4W	General Resistor	4
10K 1/4W	General Resistor	4
1M 1/4W	General Resistor	2

2.3 Outlook View:



Back side



Front side

Fig: 1.2 Outlook view

2.4 Working principle

In this circuit, there are three switches to operate the transmitter. By using this switch, one can control three devices like one fan, two lights. By adding an extra circuitry to the actual remote, the control circuit can even be used to control the speed of the fan for in nine steps.

In the transmitter section, there is a NE555 timer and infrared LEDs. The NE555 timer is configured in a stable mode, and in infrared LEDs, the IR rays are directed by the source of power, which is from 3V battery and concave lens. In the transmitter section, a switch plays a key role; when the switch is closed, the power from the battery turns on, and the 555 timer acts as a stable multi-vibrator and the output of the 555 timer gets connected to the input of the IR LEDs. Then, the infrared LEDs get high and produce the IR beam through concave lens.

The IR beam in the transmitter section produced by the infrared LEDs is directed to the receiver section. The photo LEDs receive the IR beam and charge the capacitor which increase the input voltage of one pin of the op-amp, and then generates high output. The output of the op-amp is given out to the pic16f676 microcontroller as an input, and then the microcontroller will drive the load through a relay to switch on or off.

Microcontroller (16F676)



Fig: 2.1 Microcontroller (16F676)

A **microcontroller** (sometimes abbreviated **μ C**, **uC** or **MCU**) is a small computer on a single integrated circuit containing a processor core, memory, and programmable input/output peripherals. Program memory in the form of Ferroelectric RAM, NOR flash or OTP ROM is also often included on chip, as well as a typically small amount of RAM. Microcontrollers are designed for embedded applications, in contrast to the microprocessors used in personal computers or other general purpose applications.

Microcontrollers are used in automatically controlled products and devices, such as automobile engine control systems, implantable medical devices, remote controls, office machines, appliances, power tools, toys and other embedded systems. By reducing the size and cost compared to a design that uses a separate microprocessor, memory, and input/output devices, microcontrollers make it economical to digitally control even more devices and processes. Mixed signal microcontrollers are common, integrating analog components needed to control non-digital electronic systems.

Some microcontrollers may use four-bit words and operate at clock rate frequencies as low as 4 kHz, for low power consumption (single-digit milliwatts or microwatts). They will generally have the ability to retain functionality while waiting for an event such as a button press or other interrupt; power consumption while sleeping (CPU clock and most peripherals off) may be just nanowatts, making many of them well suited for long lasting battery applications. Other microcontrollers may serve performance-critical roles, where they may need to act more like a digital signal processor (DSP), with higher clock speeds and power consumption.

History

The first microprocessor was the 4-bit Intel 4004 released in 1971, with the Intel 8008 and other more capable microprocessors becoming available over the next several years. However, both processors required external chips to implement a working system, raising total system cost, and making it impossible to economically computerize appliances.

The Smithsonian Institution says TI engineers Gary Boone and Michael Cochran succeeded in creating the first microcontroller in 1971. The result of their work was the TMS 1000, which became commercially available in 1974. It combined read-only memory, read/write memory, processor and clock on one chip and was targeted at embedded systems.

Partly in response to the existence of the single-chip TMS 1000, Intel developed a computer system on a chip optimized for control applications, the Intel 8048, with commercial parts first shipping in 1977.^[2] It combined RAM and ROM on the same chip. This chip would find its way into over one billion PC keyboards, and other numerous applications. At that time Intel's President, Luke J. Valenter, stated that the microcontroller was one of the most successful in the company's history, and expanded the division's budget over 25%.

Most microcontrollers at this time had two variants. One had an erasable EPROM program memory, with a transparent quartz window in the lid of the package to allow it to be erased by exposure to ultraviolet light. The other was a PROM variant which was only programmable once; sometimes this was signified with the designation OTP, standing for "one-time programmable". The PROM was actually exactly the same type of memory as the EPROM, but because there was no way to expose it to ultraviolet light, it could not be erased. The erasable versions required ceramic packages with quartz windows, making them significantly more expensive than the OTP versions, which could be made in lower-cost opaque plastic packages. For the erasable variants, quartz was required, instead of less expensive glass, for its transparency to ultraviolet—glass is largely opaque to UV—but the main cost differentiator was the ceramic package itself.

In 1993, the introduction of EEPROM memory allowed microcontrollers (beginning with the Microchip PIC16x84) to be electrically erased quickly without an expensive package as required for EPROM, allowing both rapid prototyping, and In System Programming. (EEPROM technology had been available prior to this time, but the earlier EEPROM was more expensive and less durable, making it unsuitable for low-cost mass-produced microcontrollers.) The same year, Atmel introduced the first microcontroller using Flash memory, a special type of EEPROM. Other companies rapidly followed suit, with both memory types.

Cost has plummeted over time, with the cheapest 8-bit microcontrollers being available for under 0.25 USD in quantity (thousands) in 2009,^[citation needed] and some 32-bit microcontrollers around 1 USD for similar quantities.

Nowadays microcontrollers are cheap and readily available for hobbyists, with large online communities around certain processors.

In the future, MRAM could potentially be used in microcontrollers as it has infinite endurance and its incremental semiconductor wafer process cost is relatively low.

Data Sheet

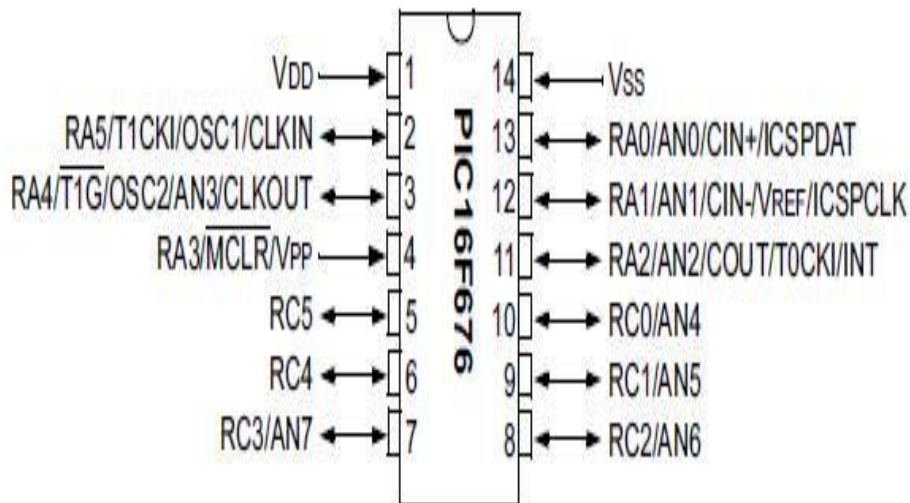

Fig: 2.2 Pin Diagram (16F676)

Ceramic capacitor

Introduction

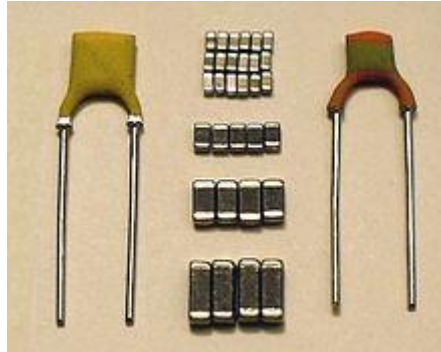

Fig: 3.1 Ceramic Capacitor

A **ceramic capacitor** is a fixed value capacitor in which ceramic material acts as the dielectric. It is constructed of two or more alternating layers of ceramic and a metal layer acting as the electrodes. The composition of the ceramic material defines the electrical behavior and therefore applications. Ceramic capacitors are divided into two application classes:

- Class 1 ceramic capacitors offer high stability and low losses for resonant circuit applications.
- Class 2 ceramic capacitors offer high volumetric efficiency for buffer, by-pass, and coupling applications.

Ceramic capacitors, especially the multilayer style (MLCC), are the most produced and used capacitors in electronic equipment that incorporate approximately one trillion pieces (1000 billion pieces) per year.^[1]

Ceramic capacitors of special shapes and styles are used as capacitors for RFI/EMI suppression, as feed-through capacitors and in larger dimensions as power capacitors for transmitters.

History

Since the beginning the study of electricity non conductive materials like glass, porcelain, paper and mica have been used as insulators. These materials some decades later were also well-suited for further use as the dielectric for the first capacitors. Porcelain was the precursor in case of all capacitors now belonging to the family of ceramic capacitors.

Even in the early years of Marconi's wireless transmitting apparatus porcelain capacitors were used for high voltage and high frequency application in the transmitters. On receiver side the smaller mica capacitors were used for resonant circuits. Mica dielectric capacitors were invented in 1909 by William Dubilier. Prior to World War II, mica was the most common dielectric for capacitors in the United States.

Mica is a natural material and not available in unlimited quantities. So in the mid-1920s the deficiency of mica and the experience in porcelain in Germany led to the first capacitors using ceramic as dielectric, founding a new family of ceramic capacitors. Para electric titanium dioxide (rutile) was used as the first ceramic dielectric because it had a linear temperature dependence of capacitance for temperature compensation of resonant circuits and can replace mica capacitors. 1926 these ceramic capacitors were produced in small quantities with increasing quantities in the 1940s. The style of these early ceramics was a disc with metallization on both sides contacted with tinned wires. This style predates the transistor and was used extensively in vacuum-tube equipment (e.g., radio receivers) from about 1930 through the 1950s.

But this paraelectric dielectric had relatively low permittivity so that only small capacitance values could be realized. The expanding market of radios in the 1930s and 1940s create a demand for higher capacitance values but below electrolytic capacitors for HF decoupling applications. Discovered in 1921, the ferroelectric ceramic material barium titanate with a permittivity in the range of 1,000, about ten times greater than titanium dioxide or mica, began to play a much larger role in electronic applications.

The higher permittivity resulted in much higher capacitance values, but this was coupled with relatively unstable electrical parameters. Therefore these ceramic capacitors only could replace the commonly used mica capacitors for applications where stability was less important. Smaller dimensions, as compared to the mica capacitors, lower production costs and independence from mica availability accelerated their acceptance.

The fast-growing broadcasting industry after the Second World War drove deeper understanding of the crystallography, phase transitions and the chemical and mechanical optimization of the ceramic materials. Through the complex mixture of different basic materials, the electrical properties of ceramic capacitors can be

precisely adjusted. To distinguish the electrical properties of ceramic capacitors, standardization defined several different application classes (Class 1, Class 2, Class 3). It is remarkable, that the different development during the War and the time afterwards in the US and the European market had leads to different definitions of these classes (EIA vs IEC) and only recently since 2010 a worldwide harmonization to the IEC standardization takes place.

The typical style for ceramic capacitors beneath the disc (at that time called condensers) in radio applications at the time after the War from the 1950s through the 1970s was a ceramic tube covered with tin or silver on both the inside and outside surface. It included relatively long terminals forming, together with resistors and other components, a tangle of open circuit wiring.

The easy-to-mold ceramic material facilitated the development of special and large styles of ceramic capacitors for high-voltage, high-frequency (RF) and power applications

With the development of semiconductor technology in the 1950s, barrier layer capacitors, or IEC class 3/EIA class IV capacitors, were developed using doped ferroelectric ceramics. Because this doped material was not suitable to produce multilayer's, they were replaced decades later by Y5V class 2 capacitors. The early style of the ceramic disc capacitor can be cheaper produced than the common ceramic tube capacitors in the 1950s and 1970s. It was an American company in the midst of the Apollo program, launched in 1961, pioneered the stacking of multiple discs to create a monolithic block. This "multi-layer ceramic capacitor" (MLCC) was compact and offered high-capacitance capacitors. The production of these capacitors using the tape casting and ceramic-electrode cofiring processes was a great manufacturing challenge. MLCCs expanded the range of applications to those requiring larger capacitance values in smaller cases. These ceramic chip capacitors were the driving force behind the conversion of electronic devices from through-hole mounting to surface-mount technology in the 1980s. Polarized electrolytic capacitors could be replaced by non-polarized ceramic capacitors, simplifying the mounting. As of 2012, more than 10^{12} MLCCs were manufactured each year. Along with the style of ceramic chip capacitors, ceramic disc capacitors are often used as safety capacitors in interference suppression applications. Besides these, large ceramic power capacitors for high voltage or high frequency transmitter applications are also to be found. New developments in ceramic materials have been made with anti-ferroelectric ceramics. This material has a nonlinear antiferroelectric/ferroelectric phase change that allows increased energy storage with higher volumetric efficiency. They are used for energy storage (for example, in detonators).

Application classes, definitions

The different ceramic materials used for ceramic capacitors, par electric or ferroelectric ceramics, influences the electrical characteristics of the capacitors. Using mixtures of par electric substances based on titanium dioxide results in very stable and linear behavior of the capacitance value within a specified temperature range and low losses at high frequencies. But these mixtures have a relatively low permittivity so that the capacitance values of these capacitors are relatively small. Higher capacitance values for ceramic capacitors can be attained by using mixtures of ferroelectric materials like barium titanate together with specific oxides. These dielectric materials have much higher permittivity's, but at the same time their capacitance value are more or less nonlinear over the temperature range, and losses at high frequencies are much higher. These different electrical characteristics of ceramic capacitors require to group them into “application classes”. The definition of the application classes comes from the standardization. As of 2013, two sets of standards were in use, one from International Electro technical Commission (IEC) and the other from the now-defunct Electronic Industries Alliance (EIA).

Unfortunately the definitions of the application classes given in the two standards are different. The following table shows the different definitions of the application classes for ceramic capacitors:

Film capacitor

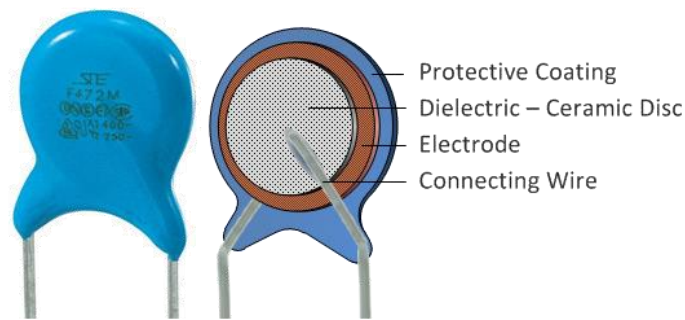

Fig: 4.2 Film Capacitor

Film capacitors, plastic film capacitors, film dielectric capacitors, or polymer film capacitors, generically called “film caps” as well as power film capacitors, are electrical capacitors with an insulating plastic film as the dielectric, sometimes combined with paper as carrier of the electrodes. The dielectric films, depending on the desired dielectric strength, are drawn in a special process to an extremely thin thickness, and are then provided with electrodes. The electrodes of film capacitors may be metalized aluminum or zinc applied directly to the surface of the plastic film, or a separate metallic foil overlying the film. Two of these conductive layers are wound into a cylinder shaped winding, usually flattened to reduce mounting space requirements on a printed circuit board, or layered as multiple single layers stacked together, to form a capacitor body. Film capacitors, together with ceramic capacitors and electrolytic capacitors, are the most common capacitor types for use in electronic equipment, and are used in many AC and DC microelectronics and electronics circuits.

A related component type is the **power (film) capacitor**. Although the materials and construction techniques used for large power film capacitors are very similar to those used for ordinary film capacitors, capacitors with high to very high power ratings for applications in power systems and electrical installations are often classified separately, for historical reasons. As modern electronic equipment gained the capacity to handle power levels that were previously the exclusive domain of "electrical power" components, the distinction between the "electronic" and "electrical" power ratings has become less distinct. In the past, the boundary between these two families was approximately at a reactive power of 200 volt-amperes, but modern power electronics can handle increasing amounts of power.

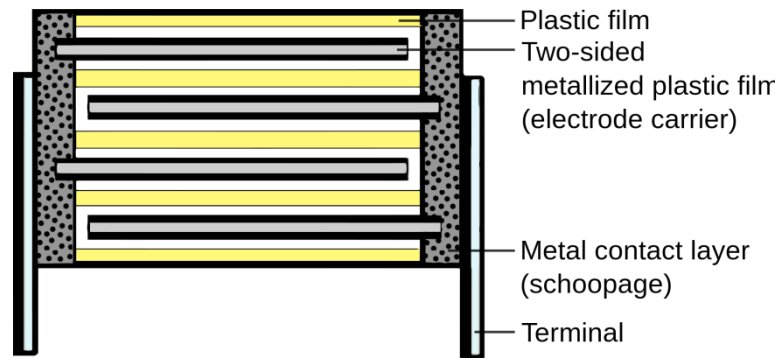

Fig: 4.2 Cross section of a plastic film capacitor

Film capacitors are made out of two pieces of plastic film covered with metallic electrodes, wound into a cylindrical shaped winding, with terminals attached, and then encapsulated. In general, film capacitors are not polarized, so the two terminals are interchangeable. There are two different types of plastic film capacitors, made with two different electrode configurations:

Film/foil capacitors or metal foil capacitors are made with two plastic films as the dielectric. Each is layered with a thin metal foil, usually aluminum, as the electrodes. Advantages of this construction type are easy electrical connection to the metal foil electrodes, and its ability to handle high current surges.

Metalized film capacitors are made of two metalized films with plastic film as the dielectric. A very thin ($\sim 0.03 \mu\text{m}$) vacuum-deposited aluminum metallization is applied to one or both sides to serve as electrodes. This configuration can have "self-healing" properties, in that dielectric breakdowns or short circuits between the electrodes do not necessarily lead to the destruction of the component. With this basic design, it is possible to make high quality products such as "zero defect" capacitors and to produce wound capacitors with larger capacitance values (up to $100 \mu\text{F}$ and larger) in smaller cases (high volumetric efficiency) compared to film/foil construction. However, a disadvantage of metalized construction is its limited current surge rating.

A key advantage of modern film capacitor internal construction is direct contact to the electrodes on both ends of the winding. This contact keeps all current paths to the entire electrode very short. The setup behaves like a large number of individual capacitors connected in parallel, thus reducing the internal ohmic losses (ESR) and the parasitic inductance (ESL). The inherent geometry of film capacitor structure results in very low ohmic

losses and a very low parasitic inductance, which makes them especially suitable for applications with very high surge currents (snubbers) and for AC power applications, or for applications at higher frequencies.

Another feature of film capacitors is the possibility of choosing different film materials for the dielectric layer to select for desirable electrical characteristics, such as stability, wide temperature range, or ability to withstand very high voltages. Polypropylene film capacitors are specified because of their low electrical losses and their nearly linear behavior over a very wide frequency range, for stability Class 1 applications in resonant circuits, comparable only with ceramic capacitors. For simple high frequency filter circuits, polyester capacitors offer low-cost solutions with excellent long-term stability, allowing replacement of more expensive tantalum electrolytic capacitors..

Typical capacitance values of smaller film capacitors used in electronics start around 100 picofarads and extend upwards to microfarads.

Unique mechanical properties of plastic and paper films in some special configurations allow them to be used in capacitors of very large dimensions.

TRIAC

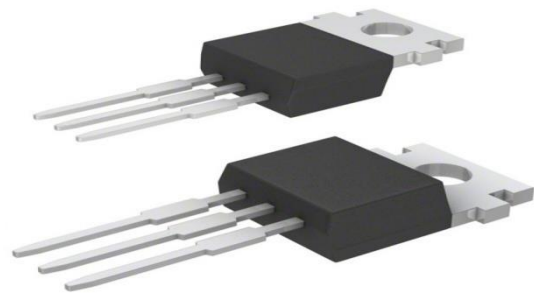
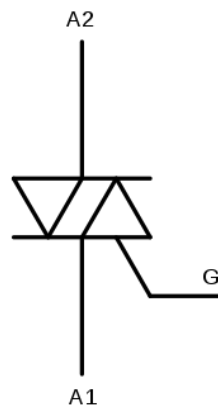

Fig: 5.2 TRIAC

TRIAC, from **triode for alternating current**, is a genericized tradename for an electronic component that can conduct current in either direction when it is triggered (turned on), and is formally called a **bidirectional triode thyristor** or **bilateral triode thyristor**.

TRIACs are a subset of thyristors and are closely related to silicon-controlled rectifiers (SCR). However, unlike SCRs, which are unidirectional devices (that is, they can conduct current only in one direction), TRIACs are bidirectional and so allow current in either direction. Another difference from SCRs is that TRIAC current can be enabled by either a positive or negative current applied to its *gate* electrode, whereas SCRs can be triggered only by positive current into the gate. To create a triggering current, a positive or negative voltage has to be applied to the gate with respect to the MT1 terminal (otherwise known as A1).

Once triggered, the device continues to conduct until the current drops below a certain threshold called the holding current.

The bidirectionality makes TRIACs very convenient switches for alternating current circuits, also allowing them to control very large power flows with milliamperes-scale gate currents. In addition, applying a trigger pulse at a controlled phase angle in an A.C. cycle allows control of the percentage of current that flows through the TRIAC to the load (phase control), which is commonly used, for example, in controlling the speed of low-power induction motors, in dimming lamps, and in controlling A.C. heating resistors.

Physical operation

To explain how TRIACs work, one has to individually analyze the triggering in each one of the four quadrants. The four quadrants are illustrated in Figure 1, according to the voltage on the gate and the MT2 terminals with respect to the MT1 terminal. The MT1 and MT2 terminals are also commonly referred to as A1 and A2, respectively.^[1]

The relative sensitivity depends on the physical structure of a particular triac, but as a rule, quadrant I is the most sensitive (least gate current required) and quadrant IV is the least sensitive (most gate current required).

In quadrants 1 and 2, MT2 is positive, and current flows from MT2 to MT1 through P, N, P and N layers. The N region attached to MT2 does not participate significantly. In quadrants 3 and 4, MT2 is negative, and current flows from MT1 to MT2, also through P, N, P and N layers. The N region attached to MT2 is active, but the N region attached to MT1 only participates in the initial triggering, not the bulk current flow.

In most applications, the gate current comes from MT2, so quadrants 1 and 2 are the only operating modes.

Zener diode

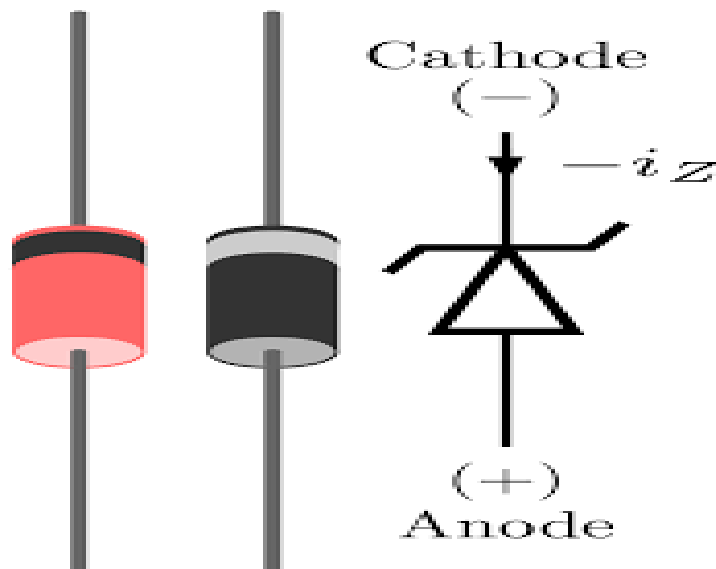

Fig: 6.1 Zener Diode

A **Zener diode** is a diode which allows current to flow in the forward direction in the same manner as an ideal diode, but also permits it to flow in the reverse direction when the voltage is above a certain value known as the breakdown voltage, "Zener knee voltage", "Zener voltage", "avalanche point", or "peak inverse voltage".

The device was named after Clarence Zener, who discovered this electrical property. Strictly speaking, a Zener diode is one in which the reverse breakdown is due to electron quantum tunneling under high electric field strength—the Zener effect. However, many diodes described as "Zener" diodes rely instead on avalanche breakdown as the mechanism. Both types are used with the Zener effect predominating under 5.6 V and avalanche breakdown above. Common applications include providing a reference voltage for voltage, or to protect other semiconductor devices from momentary voltage pulses.

Operation



Current-voltage characteristic of a Zener diode with a breakdown voltage of 17 volts. Notice the change of voltage scale between the forward biased (positive) direction and the reverse biased (negative) direction.



TC depending on Zener voltage

Fig: 6.2 C-V characteristics

A conventional solid-state diode allows significant current if it is reverse-biased above its reverse breakdown voltage. When the reverse bias breakdown voltage is exceeded, a conventional diode is subject to high current due to avalanche breakdown. Unless this current is limited by circuitry, the diode may be permanently damaged due to overheating. A Zener diode exhibits almost the same properties, except the device is specially designed so as to have a reduced breakdown voltage, the so-called Zener voltage. By contrast with the conventional device, a reverse-biased Zener diode exhibits a controlled breakdown and allows the current to keep the voltage across the Zener diode close to the Zener breakdown voltage. For example, a diode with a Zener breakdown voltage of 3.2 V exhibits a voltage drop of very nearly 3.2 V across a wide range of reverse currents. The Zener diode is therefore ideal for applications such as the generation of a reference voltage (e.g. for an amplifier stage), or as a voltage stabilizer for low-current applications.^[1]

Another mechanism that produces a similar effect is the avalanche effect as in the avalanche diode.^[1] The two types of diode are in fact constructed the same way and both effects are present in diodes of this type. In silicon diodes up to about 5.6 volts, the Zener effect is the predominant effect and shows a marked negative temperature coefficient. Above 5.6 volts, the avalanche effect becomes predominant and exhibits a positive temperature coefficient.^[2]

In a 5.6 V diode, the two effects occur together, and their temperature coefficients nearly cancel each other out, thus the 5.6 V diode is useful in temperature-critical applications.

An alternative, which is used for voltage references that need to be highly stable over long periods of time, is to use a Zener diode with a temperature coefficient of $+2 \text{ mV}/^\circ\text{C}$ (breakdown voltage 6.2–6.3 V) connected in series with a forward-biased silicon diode (or a transistor B-E junction) manufactured on the same chip.^[3] The forward-biased diode has a temperature coefficient of $-2 \text{ mV}/^\circ\text{C}$, causing the TCs to cancel out.

Modern manufacturing techniques have produced devices with voltages lower than 5.6 V with negligible temperature coefficients, but as higher-voltage devices are encountered, the temperature coefficient rises dramatically. A 75 V diode has 10 times the coefficient of a 12 V diode.

Zener and avalanche diodes, regardless of breakdown voltage, are usually marketed under the umbrella term of "Zener diode".

Construction

The Zener diode's operation depends on the heavy doping of its p-n junction. The depletion region formed in the diode is very thin ($<1 \mu\text{m}$) and the electric field is consequently very high (about 500 kV/m) even for a small reverse bias voltage of about 5 V, allowing electrons to tunnel from the valence band of the p-type material to the conduction band of the n-type material.

In the atomic scale, this tunneling corresponds to the transport of valence band electrons into the empty conduction band states; as a result of the reduced barrier between these bands and high electric fields that are induced due to the relatively high levels of dopings on both sides.^[2] The breakdown voltage can be controlled quite accurately in the doping process. While tolerances within 0.07% are available, the most widely used tolerances are 5% and 10%. Breakdown voltage for commonly available Zener diodes can vary widely from 1.2 volts to 200 volts.

Electrolytic capacitor



Fig: 7.1 Electrolytic Capacitor

Electrolytic capacitor is the generic term for three different capacitor family members:

- Aluminum electrolytic capacitors, Tantalum electrolytic capacitors and Niobium electrolytic capacitors

All **electrolytic capacitors** (e-caps) are polarized capacitors whose anode electrode (-) are made of a special metal on which an insulating oxide layer originates by anodization (forming), which acts as the dielectric of the electrolytic capacitor. A non-solid or solid electrolyte which covers the surface of the oxide layer in principle serves as the second electrode (cathode) (+) of the capacitor.

Due to their very thin dielectric oxide layer and enlarged anode surface electrolytic capacitors have—based on the volume—a much higher capacitance-voltage product compared to ceramic capacitors or film capacitors, but an articulately smaller CV value than electrochemical supercapacitors.

The large capacitance of electrolytic capacitors makes them particularly suitable for passing or bypassing low-frequency signals up to some mega-hertz and storing large amounts of energy. They are widely used for decoupling or noise filtering in power supplies and DC link circuits for variable-frequency drives, for couple signals between amplifier stages, and store energy as in a flashlamp.

Standard electrolytic capacitors are polarized components due to their asymmetrical construction, and may only be operated with a higher voltage on the anode than on the cathode at all times. Voltages with reverse polarity, or voltage or ripple current higher than specified, can destroy the dielectric and thus the capacitor. The destruction of electrolytic capacitors can have catastrophic consequences (explosion, fire).

Bipolar electrolytic capacitors which may be operated with either polarity are special constructions with two anodes connected in reverse polarity.

Basic information

As to the basic construction principles of electrolytic capacitors, there are three different types: aluminum, tantalum, and niobium capacitors. Each of these three capacitor families uses non-solid and solid manganese dioxide or solid polymer electrolytes, so a great spread of different combinations of anode material and solid or non-solid electrolytes is available.

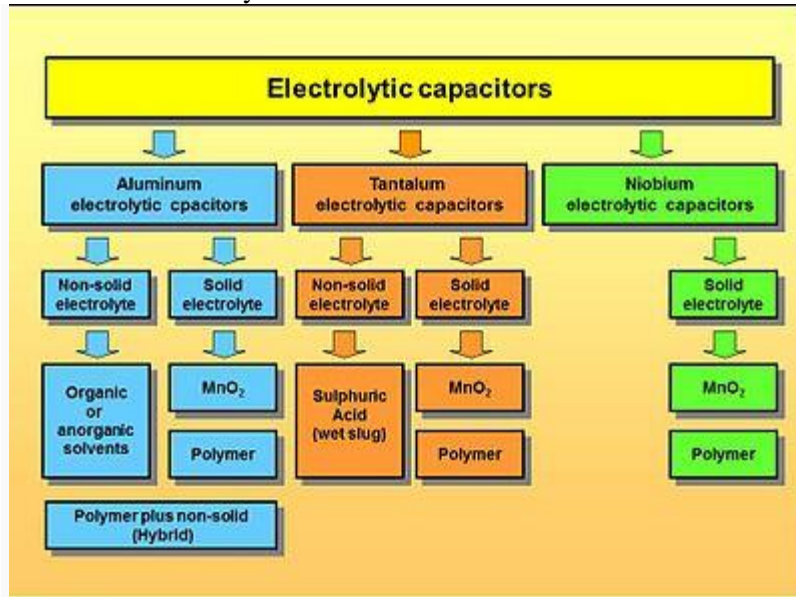

Fig: 7.2 basic information chart of electrolytic capacitor

Depending on the nature of the anode metal used and the electrolyte used, there is a wide variety of electrolytic capacitors

Charge principle

Like other conventional capacitors, electrolytic capacitors store the electric energy statically by charge separation in an electric field in the dielectric oxide layer between two electrodes. The non-solid or solid electrolyte in principle is the cathode, which thus forms the second electrode of the capacitor. This and the storage principle distinguish them from electrochemical supercapacitors, in which the electrolyte generally is the conductive connection between two electrodes and the storage occurs with statically double-layer capacitance and electrochemical pseudo capacitance.

Momentary Switch



Fig: 8.1 Momentary Switch

A common question asked by new student of electronics is what is a momentary switch? The short answer is that a momentary switch is a unit capable of turning any electronic device to either an on or off state when an end-user presses the switch. This type of switch can actually represent one of two types with the alternative being the traditional on or off switch. They can be found in all manner of electronic devices and usually take the form of a button to help initiate the state change in a device. The two types of momentary switch commonly used throughout industry are push-to-break and push-to-make types.

What is a Switch?

The most basic switch has two contacts or conductive pieces that are connected to an external circuit. These contacts are commonly made up of metal and they are normally required to touch to complete the circuit and to separate to open the circuit. Engineers will normally choose the contact material for the circuit for its ability to resist corrosion. This is due to the fact of most metals forming an insulating oxide that prevents a switch from operating properly. Other qualities considered for contact materials in switches include cost, low toxicity, hardness, mechanical strength, and electrical conductivity. In some switch designs, engineers may use a minimum wetting current in order to help prevent insulating oxides from forming.

Working Principle and Application

Momentary switches are designed to act in the manner of a regular switch in order to help connect two metal contacts with the goal of completing an electrical circuit. The primary way that they differ from a traditional switch; however, is that the momentary switch normally requires a button to be pressed to change the state of the switch vice the flicking action required of a traditional light or equivalent switch. When the “push-to-make” type of momentary switch is pressed, it will connect the metal contacts of the switch when pressed. When the button is released, the contacts will be released. A push-to-break momentary switch has to be pressed; however, to disconnect the connected electrical circuit and released to then reconnect it.

There are a variety of applications that use momentary switches in every-day life. For example, a button in an elevator is a push-to-break momentary switch that does not release the electromagnetic door until it is pressed. Another common example is the keys on a keyboard which are push-to-make momentary switches. When a key is pressed, the electrical circuit for the respective key is completed. Additional examples of momentary switches include doorbells, anti-theft alarms, and laser pointers.

Advantage

There are a number of advantages that make momentary switches better to use than a traditional on/off switch. One such case is when an electronic device or a system design requires activation or deactivation on user demand. The momentary switch can be used to create a temporary effect allowing for the system to recognize the end-user’s input. The switch can then be toggled while the user is still holding the switch. As an example, a laser pointer is only activated when the user presses the button the device to highlight some object or presentation with the device. When the desired effect is achieved, the user depresses the button and the device extinguishes.

INFARED SENSOR

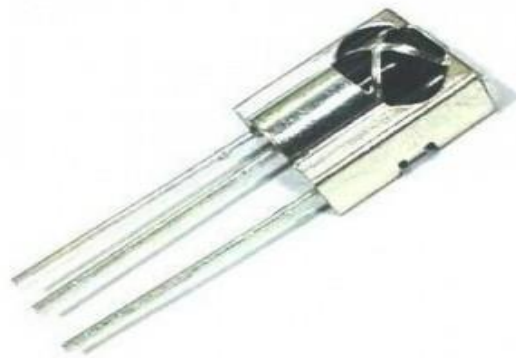

Fig: 9.1 IR Sensor

An infrared sensor is an electronic device that emits and/or detects infrared radiation in order to sense some aspect of its surroundings. Infrared sensors can measure the heat of an object, as well as detect motion. Many of these types of sensors only measure infrared radiation, rather than emitting it, and thus are known as passive infrared (PIR) sensors.

All objects emit some form of thermal radiation, usually in the infrared spectrum. This radiation is invisible to our eyes, but can be detected by an infrared sensor that accepts and interprets it. In a typical infrared sensor like a motion detector, radiation enters the front and reaches the sensor itself at the center of the device. This part may be composed of more than one individual sensor, each of them being made from piezoelectric materials, whether natural or artificial. These are materials that generate an electrical voltage when heated or cooled.

These piezoelectric materials are integrated into a small circuit board. They are wired in such a way so that when the sensor detects an increase in the heat of a small part of its field of view, it will trigger the motion detector's alarm. It is very common for an infrared sensor to be integrated into motion detectors like those used as part of a residential or commercial security system.

Most motion detectors are fitted with a special type of lens, called a Fresnel lens, on the sensor face. A set of these lenses on a motion detector can focus light from many directions, giving the sensor a view of the whole area. Instead of Fresnel lenses, some motion detectors are fitted with small parabolic mirrors which serve the same purpose.

An infrared sensor can be thought of as a camera that briefly remembers how an area's infrared radiation appears. A sudden change in one area of the field of view, especially one that moves, will change the way electricity goes from the piezoelectric materials through the rest of the circuit. This will trigger the motion

detector to activate an alarm. If the whole field of view changes temperature, this will not trigger the device. This makes it so that sudden flashes of light and natural changes in temperature do not activate the sensor and cause false alarms.

Infrared motion detectors used in residential security systems are also desensitized somewhat, with the goal of preventing false alarms. Typically, a motion detector like these will not register movement by any object weighing less than 40 pounds (18 kg). With this modification, household pets will be able to move freely around the house without their owners needing to worry about a false alarm. For households with large pets, sensors with an 80-pound (36 kg) allowance are also made.

Light-emitting diode

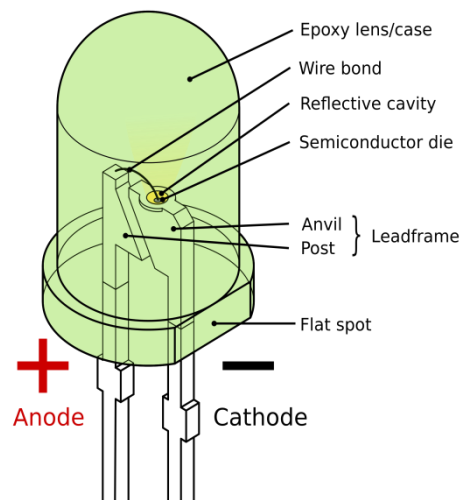

Fig: 10.1 Light Emitting Diode(LED)

A **light-emitting diode (LED)** is a two-lead semiconductor light source. It is a pn-junction diode, which emits light when activated.^[4]When a suitable voltage is applied to the leads, electrons are able to recombine with electron holes within the device, releasing energy in the form of photons. This effect is called electroluminescence, and the color of the light (corresponding to the energy of the photon) is determined by the energy band gap of the semiconductor.

An LED is often small in area (less than 1 mm²) and integrated optical components may be used to shape its radiation pattern.^[5]

Appearing as practical electronic components in 1962,^[6] the earliest LEDs emitted low-intensity infrared light. Infrared LEDs are still frequently used as transmitting elements in remote-control circuits, such as those in remote controls for a wide variety of consumer electronics. The first visible-light LEDs were also of low intensity, and limited to red. Modern LEDs are available across the visible,ultraviolet, and infrared wavelengths, with very high brightness.

Early LEDs were often used as indicator lamps for electronic devices, replacing small incandescent bulbs. They were soon packaged into numeric readouts in the form of seven-segment displays, and were commonly seen in digital clocks.

Recent developments in LEDs permit them to be used in environmental and task lighting. LEDs have many advantages over incandescent light sources including lower energy consumption, longer lifetime, improved physical robustness, smaller size, and faster switching. Light-emitting diodes are now used in applications as diverse as aviation lighting, automotive headlamps, advertising, general lighting, traffic signals, and camera

flashes. However, LEDs powerful enough for room lighting are still relatively expensive, and require more precise current and heat management than compact fluorescent lamp sources of comparable output.

LEDs have allowed new text, video displays, and sensors to be developed, while their high switching rates are also useful in advanced communications technology.

History

Electroluminescence as a phenomenon was discovered in 1907 by the British experimenter H. J. Round of Marconi Labs, using a crystal of silicon carbide and a cat's-whisker detector.^{[7][8]} Soviet inventor Oleg Losev reported creation of the first LED in 1927.^[9] His research was distributed in Soviet, German and British scientific journals, but no practical use was made of the discovery for several decades.^{[10][11]} Kurt Lehovec, Carl Accardo and Edward Jamgochian, explained these first light-emitting diodes in 1951 using an apparatus employing SiCrystals with a current source of battery or pulse generator and with a comparison to a variant, pure, crystal in 1953.

Rubin Braunstein of the Radio Corporation of America reported on infrared emission from gallium arsenide (GaAs) and other semiconductor alloys in 1955.^[15] Braunstein observed infrared emission generated by simple diode structures using gallium antimonide(GaSb), GaAs, indium phosphide (InP), and silicon-germanium (SiGe) alloys at room temperature and at 77 kelvins.

In 1957, Braunstein further demonstrated that the rudimentary devices could be used for non-radio communication across a short distance. As noted by Kroemer^[16] Braunstein".. had set up a simple optical communications link: Music emerging from a record player was used via suitable electronics to modulate the forward current of a GaAs diode. The emitted light was detected by a PbS diode some distance away. This signal was fed into an audio amplifier, and played back by a loudspeaker. Intercepting the beam stopped the music. We had a great deal of fun playing with this setup." This setup presaged the use of LEDs for optical communication application.

In the fall of 1961, while working at Texas Instruments Inc. in Dallas, TX, James R. Biard and Gary Pittman found that gallium arsenide(GaAs) emitted infrared light when electric current was applied. On August 8, 1962, Biard and Pittman filed a patent titled "Semiconductor Radiant Diode" based on their findings, which described a zinc diffused p-n junction LED with a spaced cathode contact to allow for efficient emission of infrared light under forward bias.

Resistor



Fig: 11.1 Resistor

A **resistor** is a passive two-terminal electrical component that implements electrical resistance as a circuit element. Resistors act to reduce current flow, and, at the same time, act to lower voltage levels within circuits. In electronic circuits resistors are used to limit current flow, to adjust signal levels, bias active elements, terminate transmission lines among other uses. High-power resistors that can dissipate many watts of electrical power as heat may be used as part of motor controls, in power distribution systems, or as test loads for generators. Fixed resistors have resistances that only change slightly with temperature, time or operating voltage. Variable resistors can be used to adjust circuit elements (such as a volume control or a lamp dimmer), or as sensing devices for heat, light, humidity, force, or chemical activity.

Resistors are common elements of electrical networks and electronic circuits and are ubiquitous in electronic equipment. Practical resistors as discrete components can be composed of various compounds and forms. Resistors are also implemented within integrated.

The electrical function of a resistor is specified by its resistance: common commercial resistors are manufactured over a range of more than nine orders of magnitude. The nominal value of the resistance will fall within a manufacturing tolerance.

COST ANALYSIS

Name	Quantity	Price(BDT)	Total (BDT)
PIC16F676	1	78X1	78
0.1uf 50V Cap	2	2X2	4
1.0uf 630V cap	1	2X1	2
0.01uf 450V Cap	3	2X1	2
BT136 TRIAC	3	20X3	60
5.6V 1W Zener Diode	2	2X2	4
1N4007 1A Diode	2	2X2	4
330uf 16V cap	2	10X2	20
100R 1W	3	3X3	9
Buttons	4	5X4	20
IR Sensor	1	16X1	16
LED	1	2X1	2
680R 1/4W	4	3X4	12
10K 1/4W	4	2X4	8
10M 1/4W	2	2X2	4
Casing	1	120X1	120
Remote	1	100X1	100

SUB TOTAL = BDT 465/=

13. Conclusion

Advantage:

- We can easily control the appliances by smart switch using remote.
- We can control three devices by one smart switch.
- Low power consumption.
- If any power fault occurs then the smart switch automatically disconnected from the system.
- If the remote doesn't work then we can control the appliances manually.
- We can control the speed of the fan in 10 steps.
- Position of the operation changeable.
- No danger of getting caught.
- Easier to operate from large dimension (aprox. 11 meter) from switch box.

Disadvantage:

- Does not work without main supply.
- Battery required for the sender necessary.
- Costly than normal switching device.
- Can't control the device by remote from the larger distance of 11 meter.

REFERENCES

- [1] [http:// microcontrollerproject.com](http://microcontrollerproject.com)
- [2] <http:// embedded.com>
- [3] <http://engineersgarage.com>
- [4] Teach yourself C by Herbert Schildt
- [5] Ansi C by Balguruswamy
- [6] <http://microc.com>
- [7] <http:// circuitstoday.com>
- [8] <http:// youtube.com>
- [9] <http://en.wikipedia.org>
- [10] <http://wiki.answers.com>
- [11] <http://www.electronics-tutorials.ws>
- [12] <http://electrical-engineering-portal.com>
- [13] <http://www.ieee-pes.org>
- [14] Daffodil International University Library.