

Smart Security Surveillance using IoT

by

Name: Sharmin Akter

Id : 142-15-3731

Name: Rehana Afroz Sima

Id : 142-15-3678

Name: Md Sohid Ullah

Id: 142-15-4074

This Report Presented in Partial Fulfillment of the Requirements for the Degree of
Bachelor of Science in Computer Science and Engineering

Supervised By

Dr. Syed Akhter Hossain

Professor and Head

Department of CSE

Daffodil International University

Co Supervisor

Dr. Sheak Rashed Haider Noori

Associate Professor

Department of Computer Science and Engineering

Daffodil International University



DAFFODIL INTERNATIONAL UNIVERSITY

Dhaka, Bangladesh

APPROVAL

This Project title “**Smart Security Surveillance using IoT**”, submitted by Sharmin Akter, Rehana Afroz Sima, Md Sohid Ullah to the Department of Computer Science and Engineering, Daffodil International University has been accepted as satisfactory for the partial fulfillment of the requirements for the degree of B.Sc. in Computer Science and Engineering and approved as to its style and contents. The presentation has been held on 7th May, 2018

BOARD OF EXAMINERS

Dr. Syed Akhter Hossain

Professor and Head

Department of Computer Science and Engineering
Daffodil International University

Chairman

Dr. Sheak Rashed Haider Noori

Associate Professor and Associate Head

Department of Computer Science and Engineering
Daffodil International University

Internal Examiner

Md Zahid Hasan

Assistant Professor

Department of Computer Science and Engineering
Daffodil International University

Internal Examiner

Dr. Mohammad Shorif Uddin

Professor

Department of Computer Science and Engineering
Jahangirnagar University

External Examiner

DECLARATION

We hereby declare that, this project has been done by us under the supervision of **Dr. Syed Akhter Hossain, Professor and Head, Department of CSE, Daffodil International University.**

We also declare that neither this project nor any part of this project has been submitted elsewhere for award of any degree or diploma.

Supervised by:

Dr. Syed Akhter Hossain
Professor and Head
Department of CSE
Faculty of Science & Information Technology
Daffodil International University

Submitted by:

Name: Sharmin Akter
Id : 142-15-3731
Department of CSE
Daffodil International University

Name: Rehana Afroz Sima
Id : 142-15-3678
Department of CSE
Daffodil International University

Name: Md Sohid Ullah
Id: 142-15-4074
Department of CSE
Daffodil International University

ACKNOWLEDGEMENT

First, we express our heartiest thanks and gratefulness to almighty Allah for his divine blessing makes us possible to complete this project successfully.

We are really grateful and wish our profound indebtedness to **Dr. Syed Akhter Hossain, Professor and Head**, Department of CSE, Daffodil International University, and Dhaka. Deep Knowledge & keen interest of our supervisor in the field of e-Commerce influenced us to carry out this project. Her endless patience, scholarly guidance, continual encouragement, constant and energetic supervision, constructive criticism, valuable advice, reading many inferior draft and correcting them at all stage have made it possible to complete this project.

We would like to express our heartiest gratitude to **Dr. Sheak Rashed Haider Noori**, Assistant Professor and Associate Head, Department of CSE, Daffodil International University, for his kind help to finish our project and also to other faculty member and the staff of CSE department of Daffodil International University.

We would like to thank our entire course mate in Daffodil International University, who took part in this discuss while completing the course work.

Finally, we must acknowledge with due respect the constant support and patience of our parents.

Abstract

With the advancement of technology and ICT, a radical change in the life is reflecting all around. In this 21st century, with the gift of the Internet, Internet of Things (IoT) has become an integral part of our everyday life [1]. IoT not only enabling our sensations of life but also imparting new genre of innovation. It has been found that IoT plays a significant role in achieving security. In this proposed project using IoT based Smart Security Surveillance System which has been planned to enhance the security of home with the help of IoT. The project intends to the smartest version of traditional doorbell with more security and flexibility. In the proposed project, whenever any type of motion is detected in front of doorbell it will take the picture and send to the user's cell phone. There is also a push button for guest interaction if needed. The user will also be able to see what is happening in front of the door in real time sitting on the Internet.

In the proposed project, a camera module is connected with raspberry PI, a small computing gadget based on Linux platform, to capture the picture of the visitor and a video on the basis of Passive Infra-Red (PIR) sensor and the button. The user will be able to interact with the doorbell through the Android app using the smartphone. The data will be sent to the server and server will send the push notification on user's phone. As we are using Raspberry Pi, PIR sensor and camera module the cost is relatively low. In the future, further AI will be added to the system for recognizing and identifying the gesture of the visitor.

Table of Content

Approval	II
Declaration	III
Acknowledgement	IV
Abstract	V
Table of Content	VI-VII
List of Figures	VIII

Chapter 1: Introduction

1.1 Objectives	1
1.2 Motivation	1
1.3 Problem Statement	2
1.4 Expected Output	2
1.5 Report Layout	2

Chapter 2: Literature Review

2.1 IoT-An Introduction	4
2.2 IoT Doorbell	4
2.3 Literature Review	4-5
2.5 Technical Challenges	6-7

Chapter 3: Proposed IoT Door Bell

3.1 Use Case Model	8
3.2 Use Case Description	9
3.3 Hardware Requirements	10-12
3.4 Software Requirements	13
3.5 Implementation Requirements	13

Chapter 4: Implementation

4.1 Block Diagram of Proposed System	14
4.2 Using Raspberry Pi	15
4.3 Flow Diagram	16
4.4 Pseudocode	17
4.5 Using Pi Camera	17
4.6 Component Layout	18
4.7 Raspberry Pi Model B+	18-22

Chapter 5: Testing and Deployment	
5.1 Physical View	23
5.2 Python Script	23
5.3 Sending Email notification	24
5.4 Guest type detection	25
Chapter 6: Conclusion and Future Scope	
6.1 Discussion and Conclusion	26
6.2 Limitation	26
6.3 Future Scope	26
References	26

List of Figures

Figure - 1.1: Raspberry Pi	1
Figure - 2.1: Swann DVR8-3425	5
Figure - 2.2: Motion Triggered wilderness camera	6
Figure - 3.1: Use Case Model	8
Figure - 3.2: Raspberry Pi and GPIO Pin	10
Figure - 3.3: Push Button	10
Figure - 3.4: Inner and outer of PIR sensor	11
Figure - 3.5: Camera Module	12
Figure - 3.6: Power Bank	12
Figure - 4.1: Block Diagram	14
Figure - 4.2: Flow Diagram	16
Figure - 4.3: Component Layout	18
Figure - 4.4: Back side of Raspberry Pi B+	21
Figure - 4.4: Front side of Raspberry Pi B+	21
Figure - 5.1: Physical View of IoT Doorbell	23
Figure - 5.2: Python Script from Console	23
Figure - 5.3: Sending Email	24
Figure - 5.4: Detect guest type	25

Chapter 1: Introduction

1.1 Objectives

The main objective of this project is to develop a cheap, flexible, sustainable Smart IoT based Doorbell to enhance the security of home or office. This is the complete solution of the problem of traditional doorbell with enhancing extra security. The user will be able to monitor his home or office from anywhere and anytime. The user will be notified if any type of suspicious entrance happens in the room with picture or video. That means whoever is coming or leaving everything can be monitored using live notification and live streaming. Another objective of this project is to explore the field of IoT and relevant things.

1.2 Motivation

IoT is one of the growing sectors of Information and communication technology and home automation or home security is the state of art of it. In general, we use traditional doorbell to interact with a guest from inside the room. But the problem is users cannot see who is outside of the room or who is clicking on the doorbell. As a result, there becomes a limitation of security. There is also some more problem of traditional doorbell. If any suspicious people moves in front of the room users cannot know about that or they are not notified what is happening in front of the room.

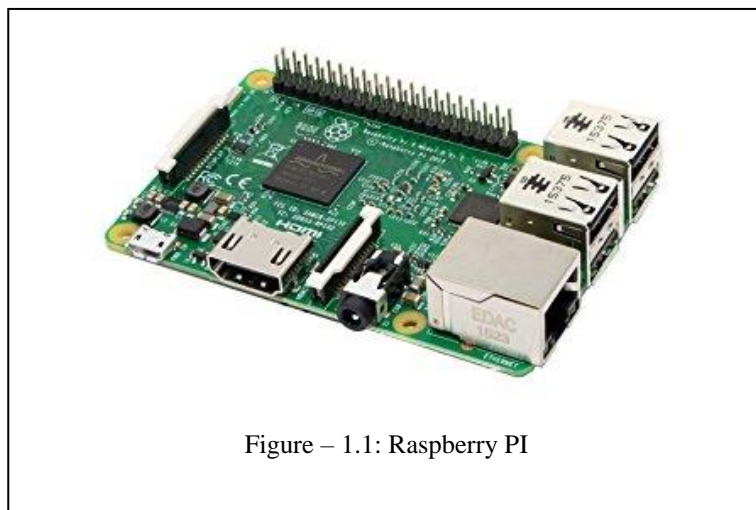

Figure – 1.1: Raspberry PI

IOT smart doorbell is the complete solution for it. If any type suspicious motion is detected it sends a notification to user's phone instantly. The user will also be able to see live streaming from android app. It will also help to identify guest before opening door. The Raspberry Pi a single board computer is one of the most popular some other systems ever built. Raspberry Pi Foundation developed it in the United Kingdom for teaching Computer Science. It is credit card sized and lite weight. Price of the Raspberry Pi is only 25 dollars it can run a full, specifically compiled Linux distribution [2]. As we are using Raspberry Pi, Pi camera, PIR sensor it is cost effective and sustainable.

1.3 Problem Statement

When a person is outside of the room or office he can't see what is happening in front of his room. On the other hand, he is not notified when a guest comes or who is come. All the guests may not come to enter in a legal way or their motive may not same. So, it is really suspicious when a person comes in front of the room but he doesn't click on the doorbell or moving suspiciously. IoT smart doorbell is a solution for it. It will notify users in real time. Users will be able to see what is happening in front of the room from in real time from anywhere.

1.4 Expected Output

The ultimate target of the project is to build a smart doorbell based on IoT. The user will be able to know the situation of home anytime from anywhere. They can simply interact with the guest or anonymous person in front of his door remotely.

1.5 Report Layout

The entire project is composed five chapter. In the report, the layout is summarized that six chapter. Discuss the summarized below:

- In chapter one gives an introduction to Smart Security Surveillance about IoT doorbell and its motivation, objective and our whole system expected output.

- In chapter two covers an extensive literature review of previous works on Security Surveillance and its system design and similar others work, Home Monitoring System and also show Technical Challenges.
- In chapter three highlights the project use case design with the description, block diagram, details about our proposal and our implementation requirements.

- In chapter four of the project design and implementation with practical details of our project design, research, and implementation for testing the project.
- In chapter five total testing and deployment process has been mentioned.
- In chapter six is on the conclusion and recommendations based on the challenges counted and future possible development of the project work are counted.

Chapter 2: Literature Review

2.1 IoT an Introduction

Internet of things (IoT) is one of the growing portions of modern technology. It is the way to control physical device by computer or software through internet. That means controlling any device from anywhere and anytime. By the year 2013, the Internet of Things had evolved into to a system using multiple technologies, ranging from the Internet to wireless communication and from micro-electromechanical systems (MEMS) to embedded systems. Experts estimate that the IoT will consist of about 30 billion objects by 2020. It is also estimated that the global market value of IoT will reach \$7.1 trillion by 2020[3]. The IoT allows objects to be sensed or controlled remotely across existing network infrastructure, creating opportunities for more direct integration of the physical world into computer-based systems and resulting in improved efficiency, accuracy and economic benefit in addition to reduced human intervention.

2.2 IoT Doorbell

The raspberry pi or the doorbell collect necessary information and store it on the public server. The public servers send the data to user's phone on the basis of the web app. The full procedures happen through the internet. Here raspberry pi or the doorbell and mobile apps are connected to the internet.

2.3 Literature Review

There are a lot of research and development going on IoT. But in case of home doorbell the existing system don't full fill the requirement. The cost of the existing system is relatively being high. Some of them are Security video surveillance System i.e. Swann DVR8-3425 and Wilderness camera. One is special for one purpose.

2.3.1 Security Video-surveillance

It is consisting of some sorts of cameras and the cameras are fixed. Each camera watches determined physical area. There is also a component called central unit which includes high-capacity hard disk. The unit store the video taken by each camera in its hard disk and keeps for a period of time. After that it is deleted and stores new one. The central unit is connected to every single camera by cables and usually allows the connection to a TV or other type of screen for live video watching. The Swann 3425 Series is an example of this type of system



Figure – 2.1: Swann DVR8-3425

It has some number of limitations. The first one is image quality. Due to quality of camera and sensor image quality is very poor. Another limitation is flexibility. Since these systems are purely focused on security applications and their software is not being adaptable to others like over-time data collection. The last one is lack of practicality. If it becomes necessary to install a new camera or relocate an existing one, the area to be covered needs to have a power source of some sort for the camera to work [4].

2.3.2 Wilderness Cameras

The device is very simple and it has limited usage. The device consists of a camera, a motion sensor, a memory card for storage. After installation it waits for the motion. Whenever any motion is detected it simply take the snaps, video of 3-4 second and store it to the memory. Though its consume low power it has some sorts of limitations. One is, video length is not sufficient and another is, it doesn't any other features i.e. remote control, live streaming. Another problem is the camera is not customizable; such as any additional function cannot be added in it.



Figure 2.2—Motion Triggered wilderness camera

The purpose of this is to observe the animal behavior where any human cannot go. As it can detect any type of animal using there is no need of human interaction. So, it can easily take the photo and video without any human interaction. Some models improve functionality with HD camera modules, GPS tagging of files, LEDs for lighting or infra-red night vision. It is powered by the battery.

2.4 Technical Challenges

In a typical IoT project we face some technical challenges. These are

- **Power Management:** Every IoT system needs a power source and proper power management to operate functionality. This can be provided by a battery or some other power sources.
- **Sensors and Actuators:** Sensors and actuators are the vital requirement for IoT system. It is needed to interact with the physical area. For that physical data is important. Sensors and actuators gathers all sorts data for experiment purpose for IoT system.
- **Wireless Communication:** The main theme of IoT is wireless communication. Without wireless communication IoT is just valueless. So, before a system design we must need proper internet connection or wireless communication.

- **Processor:** Processor is must for any IoT system. Processor is needed to read data, manipulate it and provide necessary behavior to physical device or physical area.
- **Hardware fault:** Hardware fault is very common challenges in hardware related tasks as well as IoT. Sometimes some hardware lost its working power slightly or completely. Sometimes it effects seriously on budgeting and time maintenance.

CHAPTER – 3: REQUIREMENTS FOR PROPOSED SYSTEM

3.1 Use Case Model of the proposed system

The use case model of the proposed system is shown in the Figure 3.1

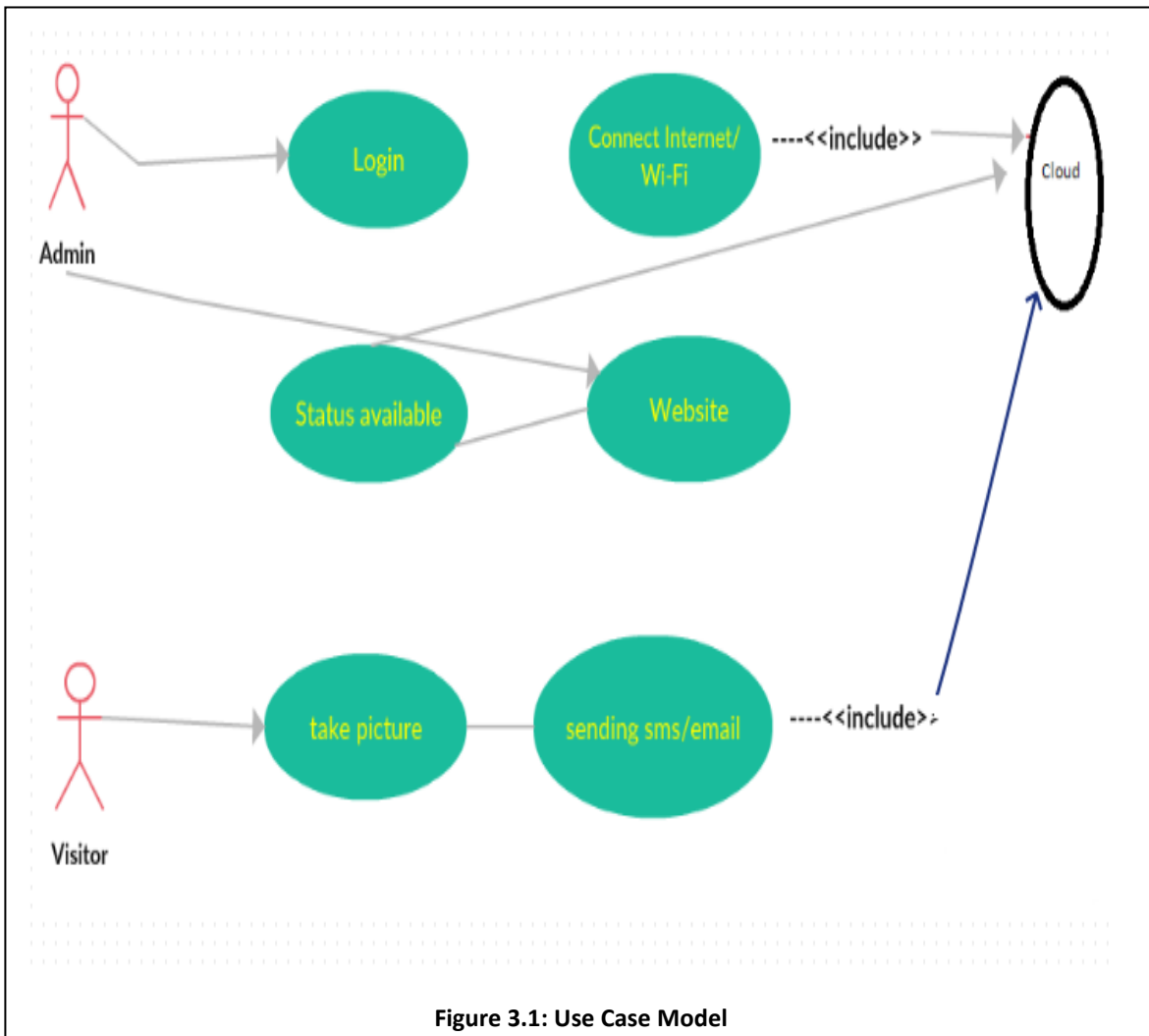

Figure 3.1: Use Case Model

There are only two actors in IoT doorbell. One is the guest and another one is the admin or the user. Admin will be able to log in and see what is happening in front of the doorbell in real time. The visitors can press the push button and the notification will be sent to the admin along with his or her photo. But if the visitor wouldn't press the button it will simply send the notification along with the photo directly to the user.

3.2 Use Case Description

Guest end: Actor – System

1. Doorbell is powered up
2. Connected to Internet through WIFI or any form of connection
3. Wait for motion or button press
4. Motion detection: Actor – System
 - a. Capture Picture
 - b. Send to Email/Mobile App
5. Button Press: Actor – Guest
 - a. Capture Picture
 - b. Send to Email/Mobile App
6. Live streaming

User End: Actor -- Admin

- a. Login
- b. Enter Login Password
- c. Press Login Button
- d. Check notification
- e. See live streaming

3.3 Hardware Requirements

3.3.1 Raspberry Pi

Raspberry Pi is a single board computer which can run Linux based Raspbian operating system. It was developed in the United Kingdom to teach basic computer science to young people. There is 40 number of GPIO pins to interact with the physical device. 4

pins for power, 8 pins for ground and rest 28 pins general purpose input-output. Using GPIO library we can simply interact with GPIO pins. There is a huge resource of python for GPIO Pins. Some other parts of raspberry pi are two 4 USB port, 1 HDMI port, one WIFI dongle, one port for camera module and another port for headphone [5]. The Raspberry Pi and Pinout shown in the figure 3.2

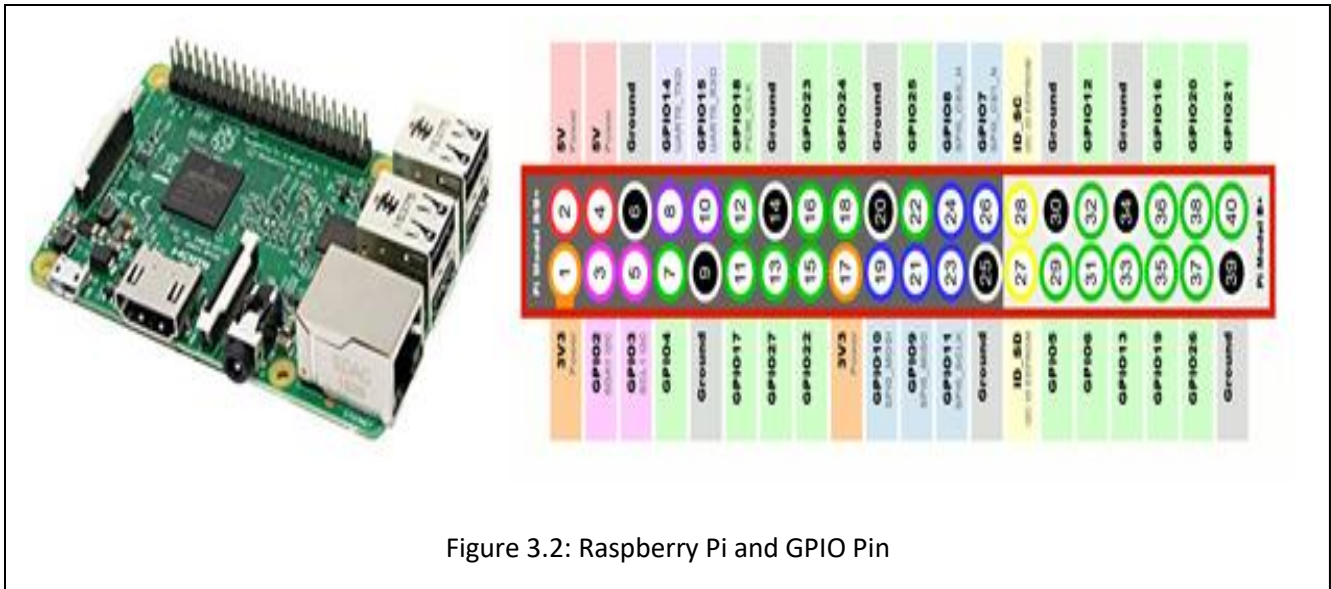

Figure 3.2: Raspberry Pi and GPIO Pin

3.3.2. Push Button

There is a switch for guest interaction. When the guest comes in front of the room or the doorbell he will simply press the switch and notification will be sent to the admin's phone through the mobile app. The push button is shown in figure 3.3



Figure 3.3: Push Button

3.3.3. PIR sensor

PIR or Passive Infrared sensor is an electric sensor to sense the motion. PIR basically made of a pyroelectric sensor which can detect the level of infrared radiation [6]. When animal moves they emit heat in form of radiation. Using that radiation PIR sensor detects animal's movement. There is a cover named Fresnel lens which focuses on the infrared signal on to the pyroelectric sensor. The inner and outer of PIR sensor shown in figure 3.4

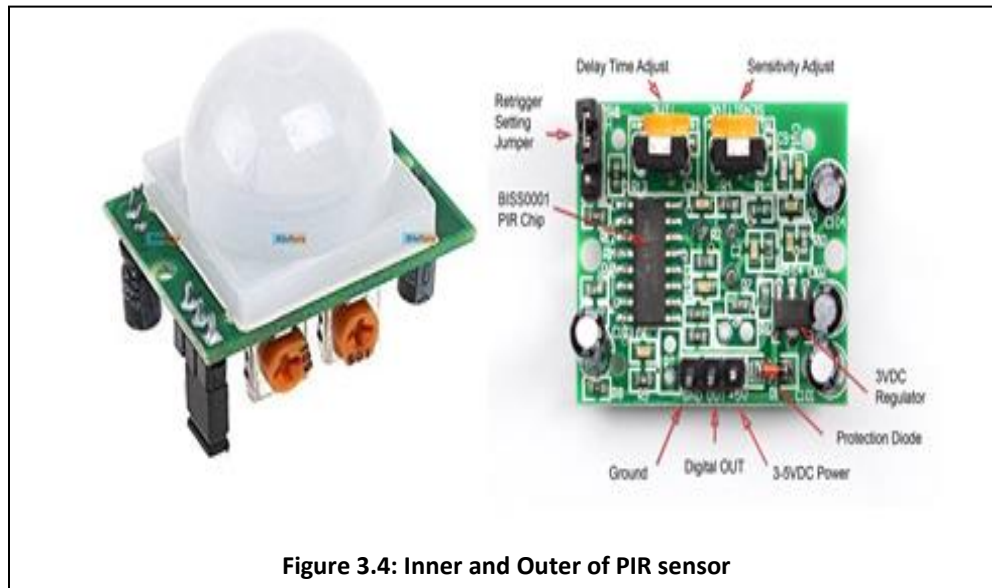

The PIR module has three pins. One is ground, one is Output and rests one is for VCC for power. There are also two potentiometers one is for adjusting the sensitivity and another one is for adjusting the time [7]

3.3.4 Camera Module

The Raspberry Pi Camera Module is an official product of the Raspberry Pi Foundation. The original 5-megapixel model was released in 2013, and an 8-megapixel Camera Module v2 was released in 2016. For both iterations, there are visible light and infrared versions [8]. The figure 3.5 showing the Raspberry Pi camera module.

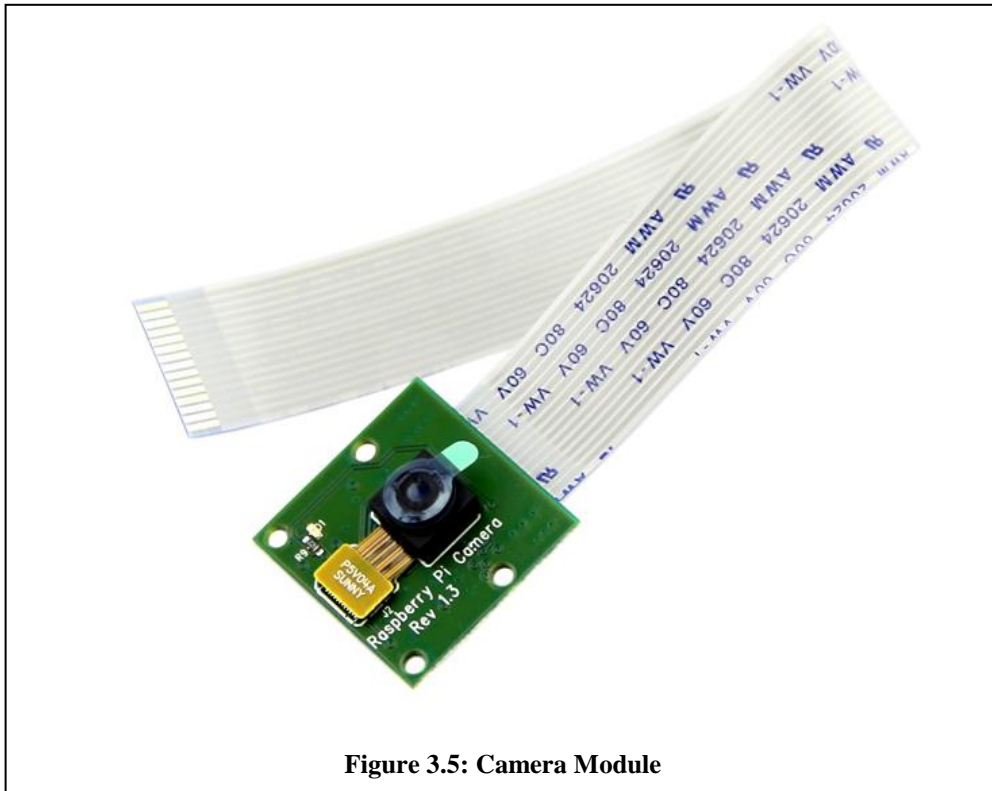

Figure 3.5: Camera Module

3.3.5. Power Bank

There needs an external power bank to power the Raspberry Pi. It will work as a 5V power supply. The figure 3.6 shown the 5V power source.

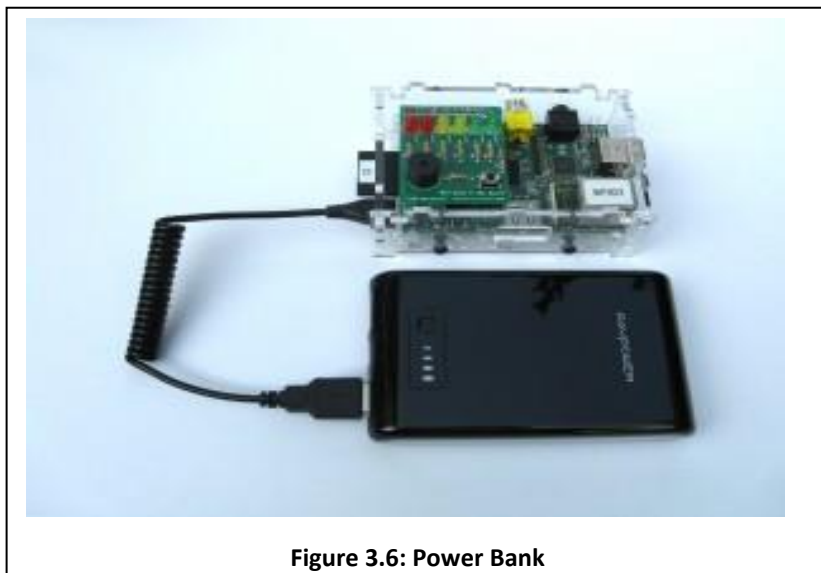

Figure 3.6: Power Bank

3.4 Software Requirements

- a. Raspbian Jessie
- b. Python
- c. Firebase (For database and real time notification)
- d. python-PI camera
- e. GPIO library

3.5 Implementation Requirements

1. Setup of SD card for Raspberry Pi
 - i. Install Raspbian OS
 - ii. Update and upgrade packages
 - iii. Update other required software packages
 - iv. Install SSH for remote access
 - v. Configure device features
 - vi. Power-up raspberry pi and check all installations

2. Develop interfacing hardware units
 - i. Get ready with PIR motion sensor
 - ii. Get ready with Camera
 - iii. Get ready with the switch
 - iv. Integrate PIR, Camera
 1. Motion is detected by PIR or press switch
 2. Picture is taken by camera
 3. Upload picture and video clip on the cloud including date and time
 4. Send email or notify to phone
3. Develop the compact unit for packaging
 - i. Design PCB and place all components

Chapter 4: IoT Door Bell Implementation

4.1 Block Diagram of Proposed System

Here is the block diagram of the proposed system. It is the whole scenario of Smart Security Surveillance System.

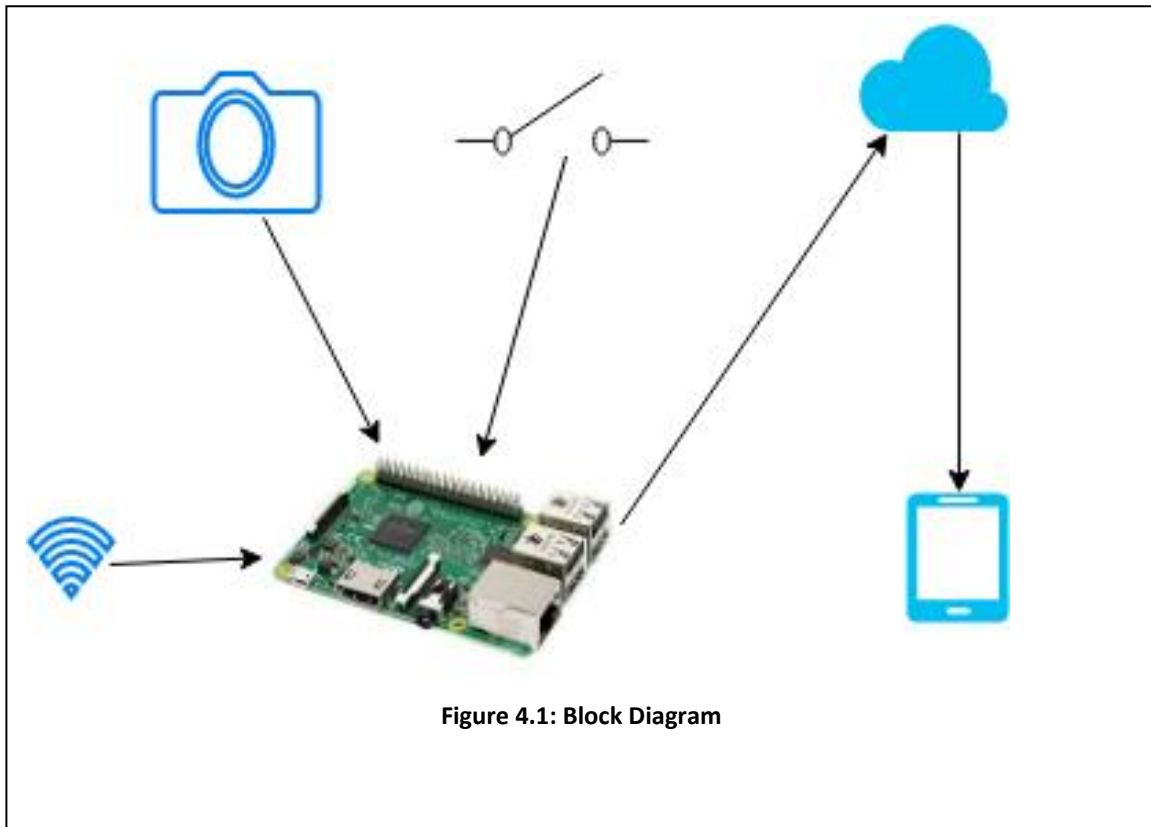

There are four elements in the project. These are WIFI, Camera, Button, Cloud Server and a mobile Phone. When Raspberry Pi is connected to the internet it is ready for surveillance. It waits for motion detection. Whenever any type of motion is detected it wait for button press only for 10 seconds. If any guest presses the button between this time it will detect as guest and send the notification to the admin. But if the particular person will not press the button it will simply send a notification to the user saying as a suspicious motion detection.

4.2 Raspberry Pi

1. Insert the microSD card in the slot given inside the underside of raspberry Pi
2. Plug the USB keyboard and mouse into one of the USB ports.
3. Turn the monitor and make sure it is set to the proper input
4. Plug the **VGA or video component cable** into the monitor the other end of the cable into the Raspberry Pi.
5. Connect router with internet.
6. Connect the other end of the cable to your Raspberry Pi. Alternately, connect the **Wi-Fi adapter** to the Raspberry Pi.
7. Connect the **power supply** to the Raspberry Pi.
8. Plug the power supply into the **power outlet**. This will turn on and boot up Raspberry Pi. A power indicator light will begin to glow, letting you know that you are connected.
9. Run “sudo raspi-config” and setup necessary equipment.
10. Press finish
11. Raspberry Pi is now ready for work

4.3 Flow Diagram

The figure 4.2 shown the flow diagram of IoT doorbell

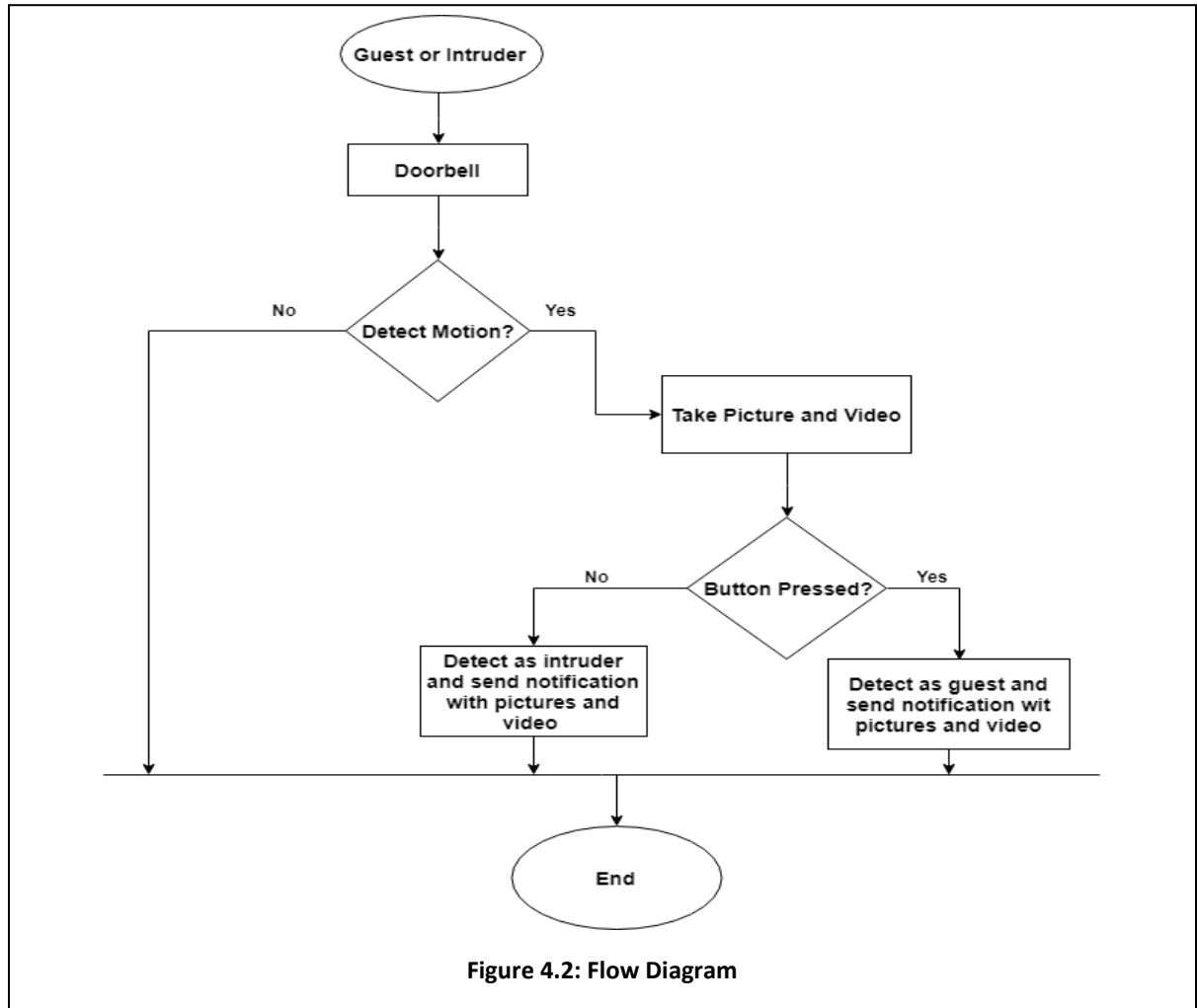

Initially, the doorbell will be connected to the internet and it will be waiting for motion or button click. When any type of motion is detected it will wait for certain period of time. After a certain period of time if it is not found any button click then it will simply send the notification as suspicious. But if the guest clicks on the button it will simply send the notification saying that there is a guest in front of the doorbell.

4.4 Pseudocode

```
1      #Pseudocode for Smart Security Surveillance System
2      #by-Team 360,Department of CSE, Daffodil Internationl University
3      #-----
4      wait for motion
5      if motion is detected:
6          Capture photo and store it to the memory
7          wait for button press for 10 second
8          if button is pressed:
9              Detect as guest and send notification to the server
10             server-> send it to the users phone
11         else
12             Detect as intruder and send notification to the server
13             server->send it to the users phone
14     else
15         Wait for motion
16
17
18
19
```

Pseudocode shown in the above figure. It is actually complete blue print of the smart Security surveillance system.

4.5Pi Camera

1. Open the raspberry Pi camera module very carefully as it is not damaged.
2. Insert the Raspberry Pi camera module into the camera slot given in the Raspberry Pi. It is situated between HDMI and ethernet ports.
3. After inserting this run `sudo apt-get update` and `sudo apt-get upgrade` from terminal.
4. Then run "`sudo raspi-config`" from terminal.
5. Navigate the camera option and enable it then press finish
3. Boot up Raspberry Pi.

4.6 Component Layout

In the figure 4.3 shown all the components of Raspberry Pi at a including GPIO pins, ARM CPU, RCA, Audio out, Power, SD card slot, Ethernet and other parts of Raspberry Pi

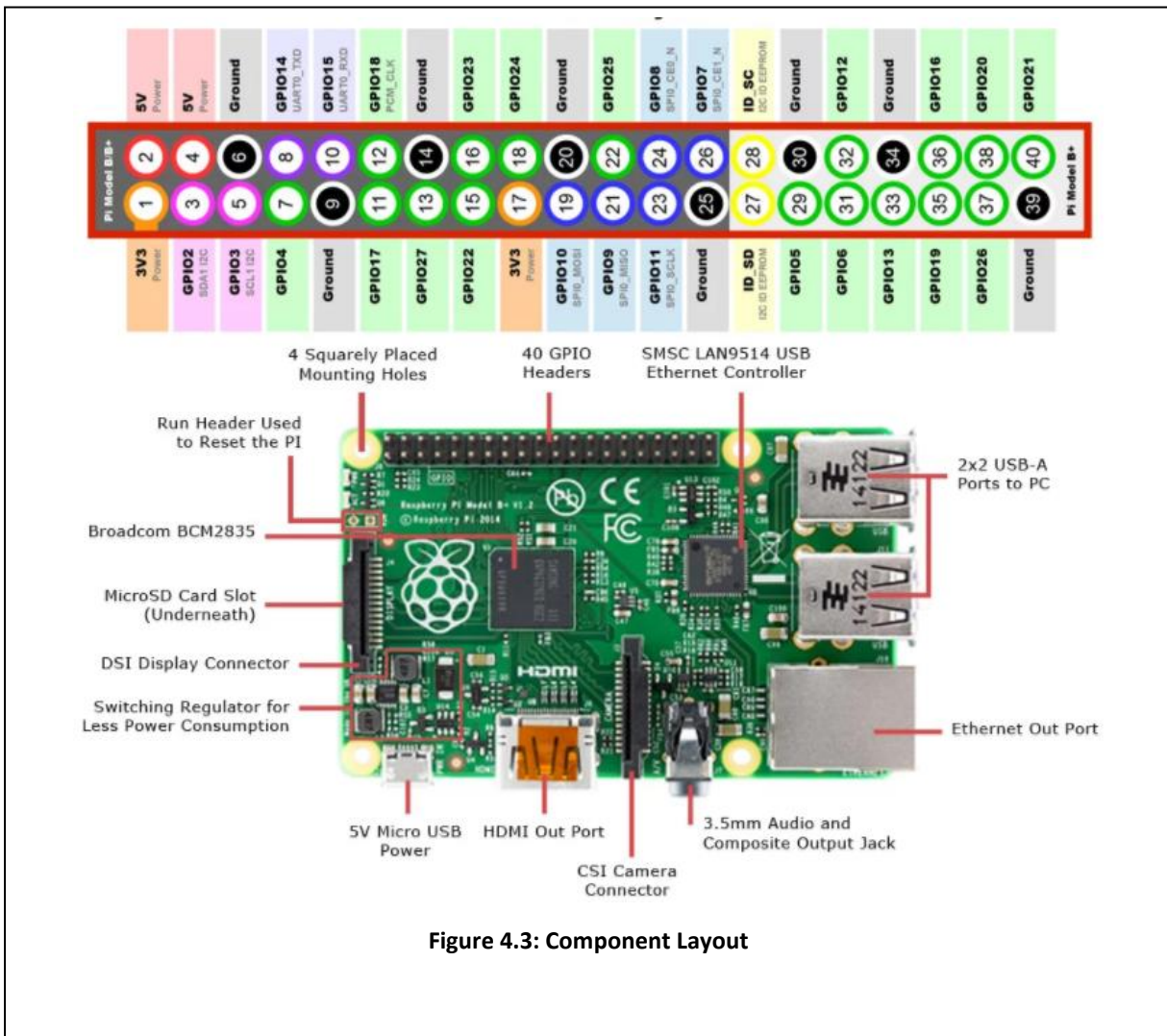

4.7 Raspberry Pi Model B+

- ARM CPU/GPU: BCM2835 system which is made up on ARM center processing unit prepared by Broadcom. It is the heart of Raspberry Pi.

- **GPIO:** It actually general-purpose input output pins for interaction with physical device.
- **RCA:** An RCA jack allows connection of analog TVs and other similar output devices.
- **Audio out:** This is a standard 3.55-millimeter jack for connection of audio output devices such as headphones or speakers. There is no audio in.
- **LEDs:** Light emitting diodes that shows the status of Raspberry Pi
- **USB:** This common connection port for mouse and keyboards or others peripheral devices. Model A has one and model B has two but it can be expanded using USB hb
- **HDMI:** This connector allows you to hook up a high-definition television or other compatible device using an HDMI cable.
- **Power:** This is a 5v Micro USB power connector into which you can plug your compatible power supply.
- **SD card slot:** This is a full-sized SD card slot. An SD card with an operating system (OS) installed is required for booting the device. They are available for purchase from the manufacturers, but you can also download an OS and save it to the card yourself if you have a Linux machine and the wherewithal.
- **Ethernet:** This connector allows for wired network access and is only available on the Model B. [9]

4.7.1 Raspberry Pi Power Supply

The power is fundamental task for any type of electric device. Proper power supply is also an important task in this case. Low power or high power can be harmful for all type of device. So, power management is important.

Normally the Raspberry Pi needs a 5V micro USB 2.1 power supply. The power can also be provided from battery. It is risky to power with battery during the connection with USB with raspberry Pi. There is also another way to power the raspberry Pi is powering from board. Raspberry has Pi 5.5V and 3-volt pin for power supply in the board.

4.7.2 Passive Infrared Sensor (PIR Sensor)

PIR the passive Infrared sensor is an electric sensor for detecting motion. It generates energy when exposed to heat. The working principle is very simple. When any animal moves, it emits energy in the form of infrared radiation. When it happens in the range of PIR sensor it simply detects the movement on the basis of that infrared radiation. From this, Passive infrared name actually comes. That means, the sensor is not using any energy but it uses the energy emitting from any other object for detecting purpose. The sensor also consists of special cover named **Frenzel lense**. It focuses the infrared signals on to the pyroelectric sensor. It has three pins; These are VCC, Ground and Output pin. There are also two potentiometers; One for adjusting the sensitivity and another is for adjusting the time of output signals.

4.7.3 Raspberry Pi Camera Module

The raspberry pi camera module which is developed by Raspberry Pi foundation. It is usable only Raspberry Pi. This programmable camera can take still photographs and high-quality video. It uses a CMOS sensor for the camera. The resolution of this camera is 5-megapixel. Using simple command, we can take the snapshot or video. The camera is connected with raspberry pi through a ribbon cable. This means that the camera and the Raspberry Pi need to be in very close proximity to each other and therefore restricting where we can put the camera. However, it is small and lightweight subsequently making it easy to place as long as it is near the Raspberry Pi. The power for this camera is enough whatever provided by board. It is very reasonably priced, only about thirty dollars. Some advantages of using the Raspberry Pi camera are that the software for the module makes use of RPi GPU, which is the Raspberry Pi graphics processing unit and thus uses less CPU. Also, the camera is fairly high quality; however, it has approximately the same megapixels as a webcam.

4.7.5 Raspberry Pi 4 - Model B+

When Raspberry Pi first released in 2012 it was decided the first light weight computer. It turns into a revolution of learning computer science. After that it upgrading and upgrading. The latest model of Raspberry Pi is Model B+ which was released at 2018. It comes with some sorts of changes. First one is the processor speed. It uses the same processor Broadcom BCM2837 but the speed increased 1.2GHZ to 1.4GHZ. That means it runs little bit speedier than the Pi 3; Second one is, networking controller.

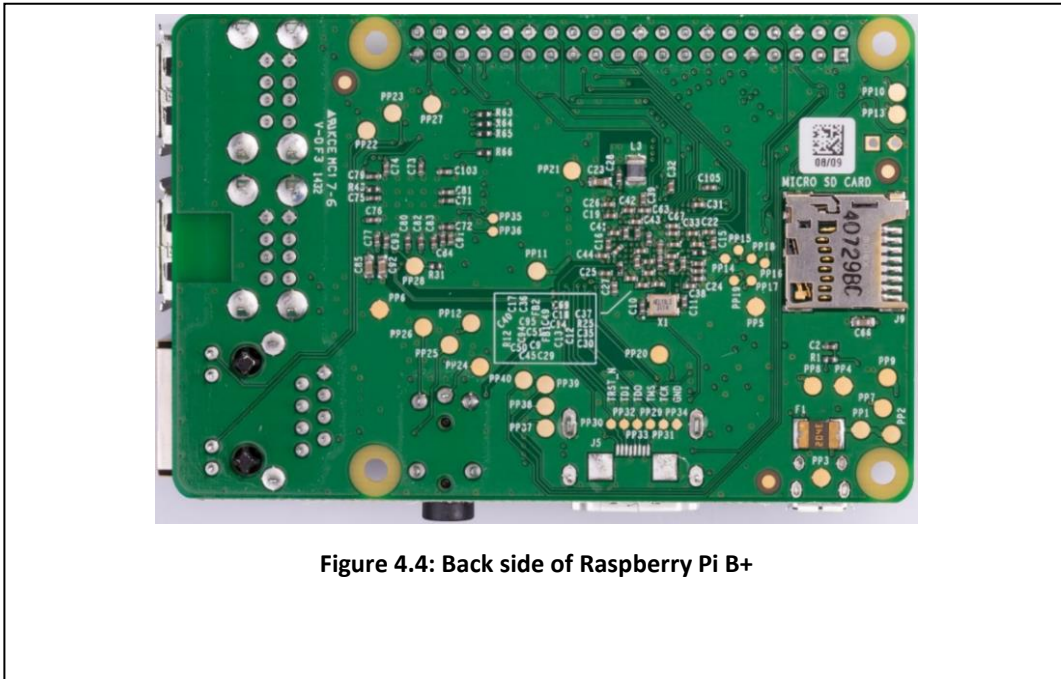

Figure 4.4: Back side of Raspberry Pi B+

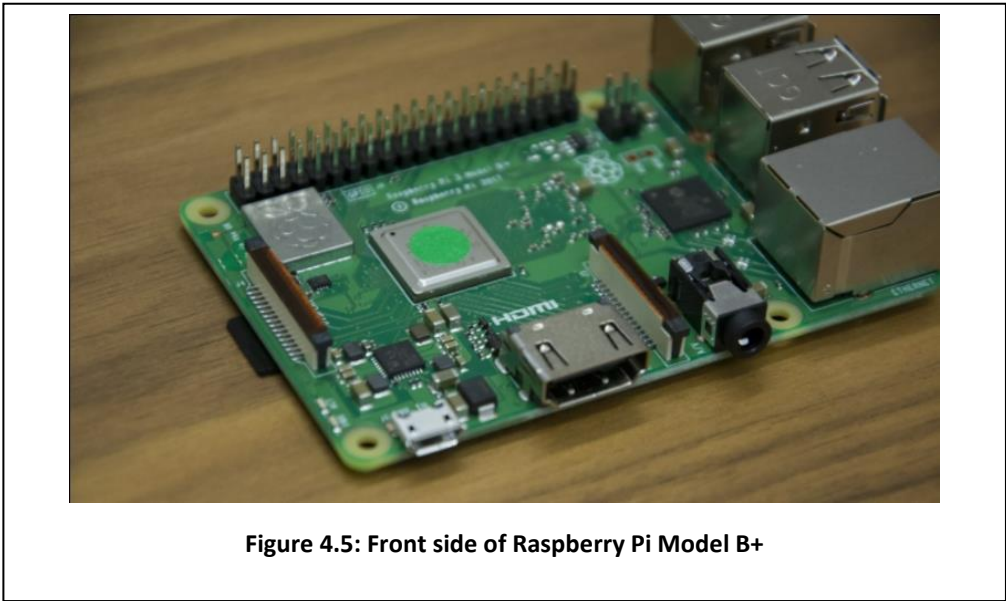

Figure 4.5: Front side of Raspberry Pi Model B+

Though Pi 3 has a built in WIFI but it only supported the comparatively slow 801.11n protocol on 2.4GHZ radio band. The built in ethernet socket speed increased

100Mbps/sec to 300Mbps/sec. The last one is specialized designed cover to reduce the heat of processor. Despite of all of these change the price remain same.

4.7.6 Raspberry Pi 3 - Model B+ Technical Specification

- Broadcom BCM2837 chipset
- 1.4GHz Quad-Core ARM Cortex-A53
- 1GB RAM
- 64 Bit CPU
- 4 x USB ports
- 4 pole Stereo output and Composite video port
- Full size HDMI
- CSI camera port for connecting the Raspberry Pi camera
- DSI display port for connecting the Raspberry Pi touch screen display
- Micro SD port for loading your operating system and storing data
- Micro USB power source
- Specialized designed cover for reducing heat.

Chapter 5: Testing and Deployment

5.1 Physical View of Smart IoT Door Bell

Front view of Smart IoT Doorbell shown in the figure 5.1

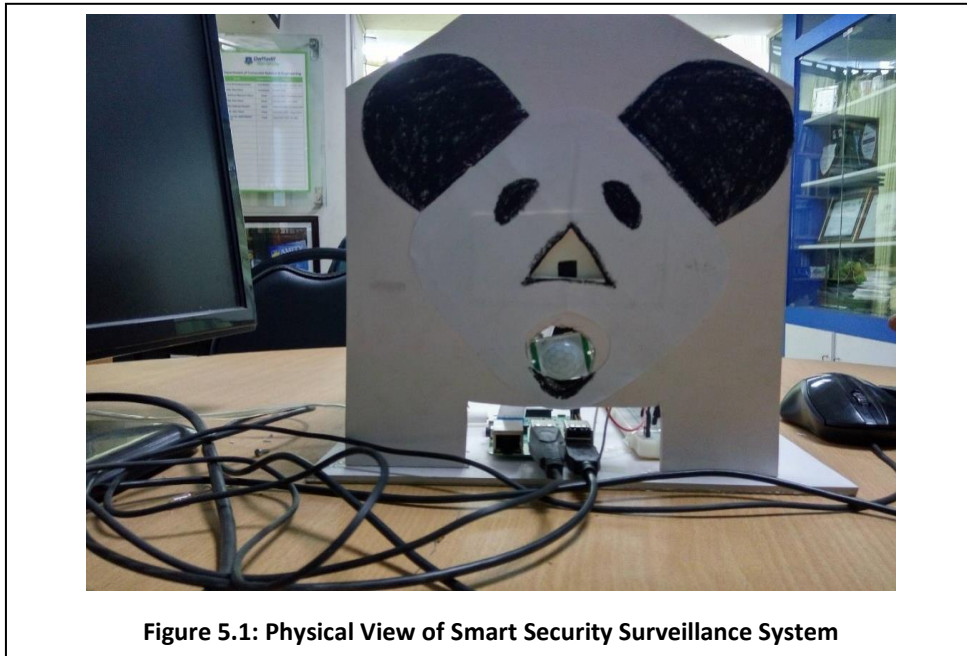

5.2 Running Python Script from Console

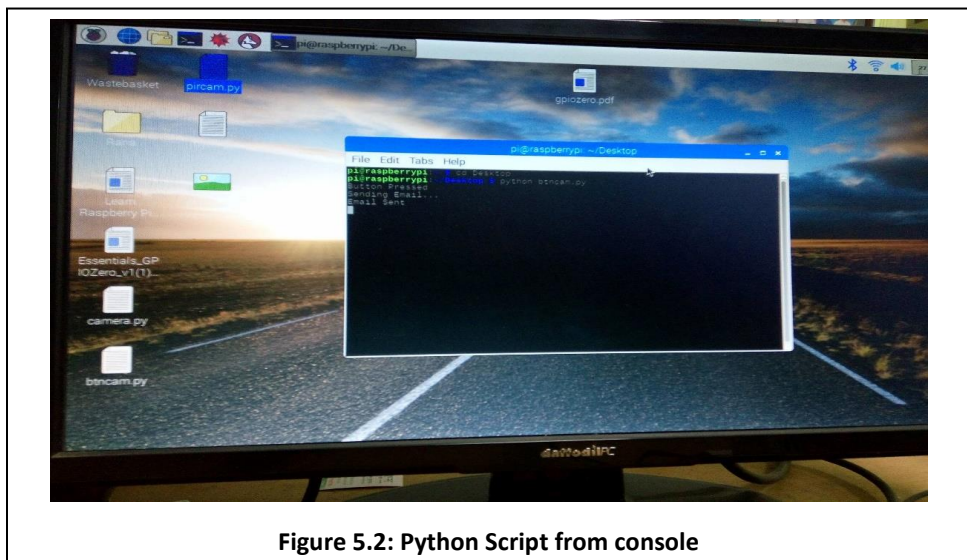

5.3 Send Captured image to Email

Captured image automatically sends to the mail using internet, showing in the figure 5.3.

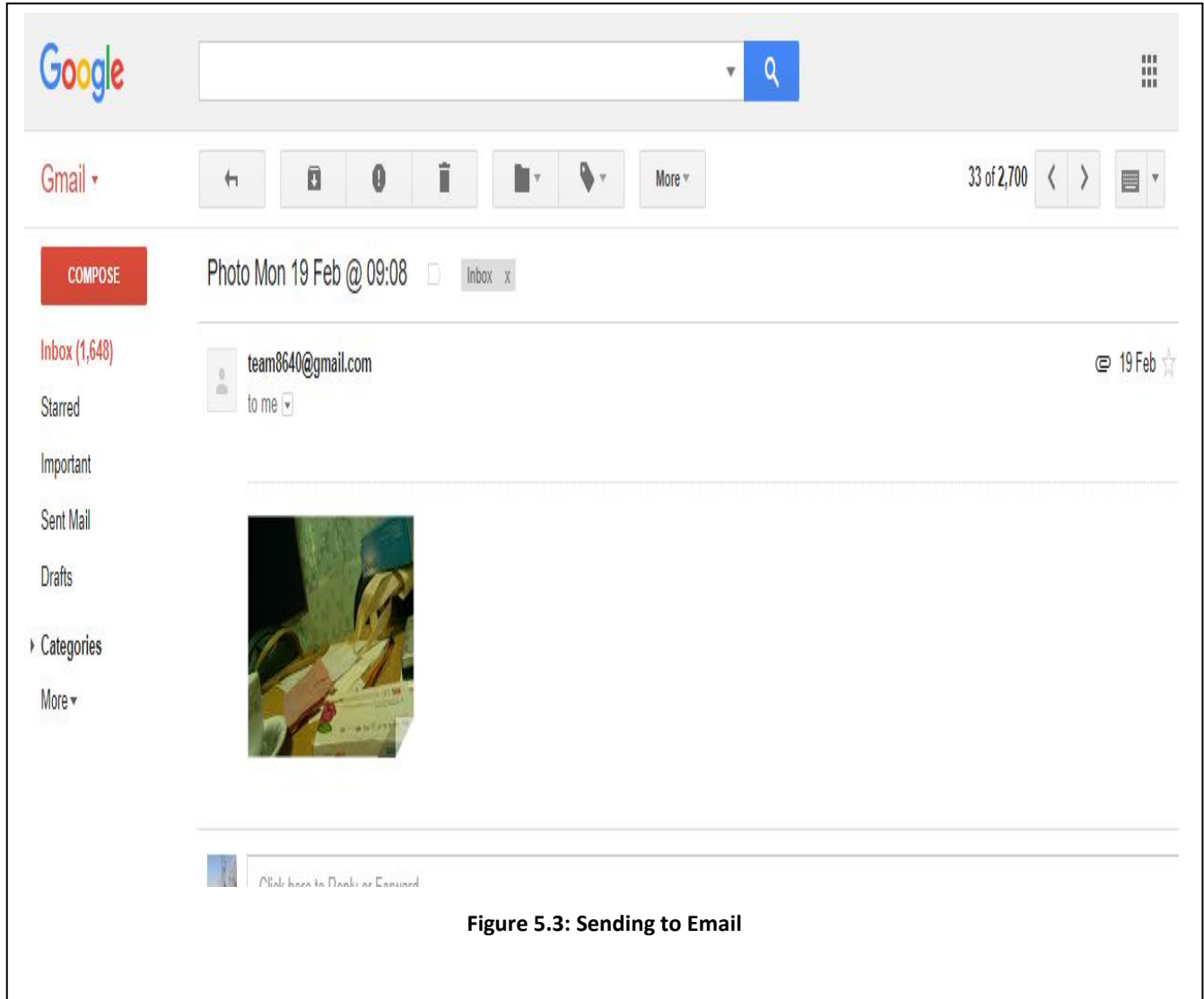

Figure 5.3: Sending to Email

5.4 Guest type detection

It can detect the type of guest, showing in the figure 5.4

<input type="checkbox"/> ☆ <input type="checkbox"/> team8640	Intruder Detected Tue 13 Mar @ 19:10
<input type="checkbox"/> ☆ <input type="checkbox"/> team8640	New Guest Tue 13 Mar @ 19:08
<input type="checkbox"/> ☆ <input type="checkbox"/> team8640	Intruder Detected Tue 13 Mar @ 19:04
<input type="checkbox"/> ☆ <input type="checkbox"/> team8640	New Guest Tue 13 Mar @ 19:03
<input type="checkbox"/> ☆ <input type="checkbox"/> team8640	Intruder Detected Tue 13 Mar @ 19:02
<input type="checkbox"/> ☆ <input type="checkbox"/> team8640	New Guest Tue 13 Mar @ 19:00
<input type="checkbox"/> ☆ <input type="checkbox"/> team8640	Intruder Detected Tue 13 Mar @ 18:59
<input type="checkbox"/> ☆ <input type="checkbox"/> team8640	Intruder Detected Tue 13 Mar @ 18:55
<input type="checkbox"/> ☆ <input type="checkbox"/> team8640	Intruder Detected Tue 13 Mar @ 18:51

Figure 5.4: Identifying the guest based on the interactions

Chapter 6: Conclusion and Future Scope

6.1 Discussion and Conclusion

The objective of this project is to build smart IoT doorbell for home security. There was also another objective of the project is to experiment the IoT in real life. As this technology was new us it was very big challenge to cope with this field. We hope we will develop this project adding more feature and make it more interactive and smart.

6.2 Limitations

Sometimes it detects wrong motion when it run python script without any human interaction.

6.2 Future Scope

- a. Action detection
- b. Live Streaming
- c. Face detection using OpenCV
- d. Door on off remotely using android app
- e. Conversation between guest and user remotely.

References

- [1] <http://www.smbnation.com/analysis/2211-iot-possibilities-in-2017>
- [2] <https://www.raspberrypi.org/help/what-is-a-raspberry-pi/>
- [3] https://en.wikipedia.org/wiki/Internet_of_things
- [4] <https://www.swann.com/us/swdvk-880758>
- [5] <https://computer.howstuffworks.com/raspberry-pi2.htm>
- [6] <https://learn.adafruit.com/pir-passive-infrared-proximity-motion-sensor?view=all>
- [7] https://en.wikipedia.org/wiki/Passive_infrared_sensor
- [8] <https://www.raspberrypi.org/documentation/hardware/camera/README.md>
- [9] <https://computer.howstuffworks.com/raspberry-pi2.htm>
- [10] Learn Raspberry Pi Programming with Python by Wolfram Donat

 Upload

 Papers

 Payments

 Free

 Earn money

RATE US



IoT DoorBell Project report-V2.doc  

4 minutes ago



Similarity

 1%
Paraphrase

 0%
Improper Citations

 19
Matches